



IN220800014V02\_US

**370-160V80**



## Children's Battery Operated Ride on Car



**WARNING!**

- The toy must be assembled by adults.

**IMPORTANT, RETAIN FOR FUTURE REFERENCE: READ CAREFULLY**

# ASSEMBLY INSTRUCTION

Specifications:	
Battery:	6V/4.5AH*1
Motor:	6V 20W
Suitable ages:	18-48 months
Maximum weight:	25kg
Speed :	0-3km/h
Power way:	Charging type
Use of time:	Charg: 8-12 hours ; Use: 0.75 hours
Charger:	Input AC 120~ 240V, 50~60Hz, output DC 6 V 500mA

### **WARNING**

1.The pictures in this instruction is only for explaining the operation and structure of the product, when there's any difference with the real product, please confirm with the real product.

2.In order to improve the quality of the product,we may amend some structure or appearance of the product without notification.Thank you for your understanding.

### **FOR THE SAFETY OF YOUR CHILD, PLEASE READ ALL WARNINGS AND ASSEMBLY/USE INSTRUCTIONS. KEEP THIS GUIDE FOR FUTURE REFERENCE.**

- ADULT ASSEMBLY REQUIRED. The product contains small parts, which are for adult assembly only. keep small children away when assembling.
- always remove protective material and poly bags and dispose before assembly.
- never leave child unattended. direct adult supervision is required.
- always keep child in view when child is in vehicle.
- Keep Children within Safe Riding Areas:  
-Never use in roadways, near motor vehicles, on lawn space, on or near steep inclines or steps, swimming pools or any other dangerous area.
- Use the toy only on flat surfaces. Such as inside your house, garden or playground.
- Never use in the dark. A child could encounter unexpected obstacles and have an accident. Operate the vehicle only in the daytime or a well-lit area.
- Please avoid running on sand or any other rough ground.
- always wear shoes.
- always sit on the seat.
- this toy has no brake.
- It is prohibited to change the circuit or add other electric parts
- Inspect wires and connections of the vehicle periodically.
- Do not let any child touch the wheels or be near them when the car is moving.
- This vehicle has adjustable play seat belts. Please instruct children how to tie the safety belt before using, guarantee the security.

## **STORAGE BATTERY INFORMATION AND MAINTENANCE**

- Please charge 8 to 12 hours before first time use.
- Please use the suitable adapter to charge storage battery, otherwise the ride-on will be damaged.
- Please charge the car once the speed is slower than normal, otherwise it will decrease storage battery life.
- Please fully charge the battery before you put your ride-on away, and remember to recharge the battery every 30 days. This will ensure the normal use of the battery, otherwise, the battery might not hold a charge without proper maintenance.
- Batteries may leak fluids that can cause chemical burn injury or ruin your product.
- To avoid battery leakage: Do not mix old and new batteries or batteries of different types: alkaline, standard (carbon-zinc) or rechargeable (nickel-cadmium).
- Insert batteries as indicated inside the battery compartment. Remove batteries during long periods of non-use.
- Always remove exhausted batteries from the product. Dispose of batteries safely. Do not dispose of batteries in a fire. The batteries may explode or leak.
- Never short-circuit the battery terminals.
- Non-rechargeable batteries are not to be recharged.
- Use only batteries of the same or equivalent type as recommended.
- Do not charge non-rechargeable batteries.
- Remove rechargeable batteries from the product before charging.
- If removable rechargeable batteries are used, they are only to be charged under adult supervision
- Every single charging can not go over 10 hours. Both charger and storage batteries will occur mildly warm during charging. Do not use mal-functioned adapter or storage battery unless they are repaired.
- Charger and storage batteries are not considered as toys.
- Please make periodical inspection for storage battery, especially for adapter wires and plugs.
- Please turn off the switch when the ride-on is not in use. Please do a full charge after long periods of inactivity.
- Charge in well ventilated, dry place. Do not open the battery or the charger.
- Tighten the screws with a screwdriver. DO NOT over tighten

### **Disposal Of Battery**

1. Your sealed lead-acid battery must be recycled or disposed of in an environmentally sound manner.
2. Do not dispose of your lead-acid battery in a fire. The battery may explode or leak.
3. Do not dispose of a lead-acid battery in your regular, household trash. The incineration, land filling or mixing of sealed lead-acid batteries with house-hold trash is prohibited by law.

## **PREVENT FIRE AND ELECTRIC SHOCK:**

- Use the only rechargeable battery and charger supplied with your vehicle.  
-NEVER substitute the battery or the charger with another brand. Using another battery or charger may cause a fire or explosion.  
-Do not use the battery or charger for any other product. Overheating, fire or explosion could occur.

- NEVER modify the electric circuit system. Tampering with the electric system may cause a shock, fire or explosion or may permanently damage the system.

-Do not allow direct contact between battery terminals. Fire or explosion can occur.

-Do not allow any type of liquid on the battery or its components.

-Explosive gasses are created during charging. Do not charge near heat or flammable materials. Charge the battery in a well-ventilated area ONLY.

- NEVER pick up the battery by the wires or charger. Damage can occur to the battery and may cause a fire. Pick up the battery by the case ONLY.

Charge the battery in a dry area ONLY.

●Battery posts, terminals and related accessories contain lead and lead compounds, chemicals known to the State of California to cause cancer and reproductive harm. Wash hands after handling.

●Do not open the battery. Battery contains lead acid and other materials that are toxic and corrosive.

●Do not open the charger. Exposed wiring and circuitry inside case may cause electric shock.

ONLY adults may handle or charge the battery. NEVER allow child to handle or charge the battery. Battery is heavy and contains lead acid (electrolyte).

●Do not drop the battery. Permanent damage to the battery could occur or cause serious injury.

●Before charging the battery, check for wear or damage to the battery, charger, its supply cord and the connectors. DO NOT charge the battery if any damage to parts has occurred.

Do not allow the battery to drain completely. Recharge the battery after each use or once a month if not used regularly.

●Do not charge battery upside down.

●Always secure the battery with the bracket. Battery can fall out and injure a child if vehicle tips over.

●It is parents' responsibility to check main parts of the toy before using, Must regularly examine for potential hazard, such as the battery, charge, cable or cord, plug, screws are fastening enclosure of other parts and that in the event of such damage, the toy must not be until that damage had been properly removed. Make sure the plastic parts of the vehicle are not cracked or broken.

●Occasionally use a lightweight oil to lubricate moving parts such as wheels.

●Park the vehicle indoors or cover it with a tarp to protect it from wet weather.

●Keep the vehicle away from sources of heat, such as stoves and heaters. Plastic parts may melt.

●Recharge the battery after each use. Only an adult can handle the battery. Recharge the battery at least once a month when the vehicle Raider is not being used.

●Do not wash the vehicle with a hose. Do not wash the vehicle with soap and water. Do not drive the vehicle in rainy or snowy weather. Water will damage the motor, electric system and battery.

●Clean the vehicle with a soft, dry cloth. To restore shine to plastic parts, use a non-wax furniture polish. Do not use car wax. Do not use abrasive cleaners.

●Do not drive the vehicle in loose dirt, sand or fine gravel which could damage moving parts, motors or the electric system.

●When not using, all the electrical source should be turn off. Turn off the power switch and disconnect the battery connection.

## Parts List

No.	Name	Q'ty (pcs)	Remark
1	Vehicle body	1	
2	Motor	1	Pre-installed
3	Wheel	2	
4	Bushing	3	Pre-installed
5	Rear axle	1	Pre-installed
6	Φ 10 washer	4	Pre-installed
7	Φ8 washer	4	Pre-installed
8	Lock nut	4	Pre-installed
9	Hubcap	2	
10	Side wheel	1	
11	Φ4x16 turss head screw	4	
12	Vehicle head	1	
13	Warning light	1	
14	Spanner	2	
15	Seat	1	Pre-installed
16	Handlebar	1	
17	Front axle	1	Pre-installed
18	Foot board	1	
19	Rear number plate	1	
20	Front fork	1	Pre-installed
21	Φ5 nut	1	Pre-installed
22	M5X40 machine screw	1	Pre-installed
23	Charger	1	
24	Guide book	1	
25	Φ4x12 Round head screw	2	

# Parts Diagram

HINT : Some parts shown are assembled on both sides of vehicle.

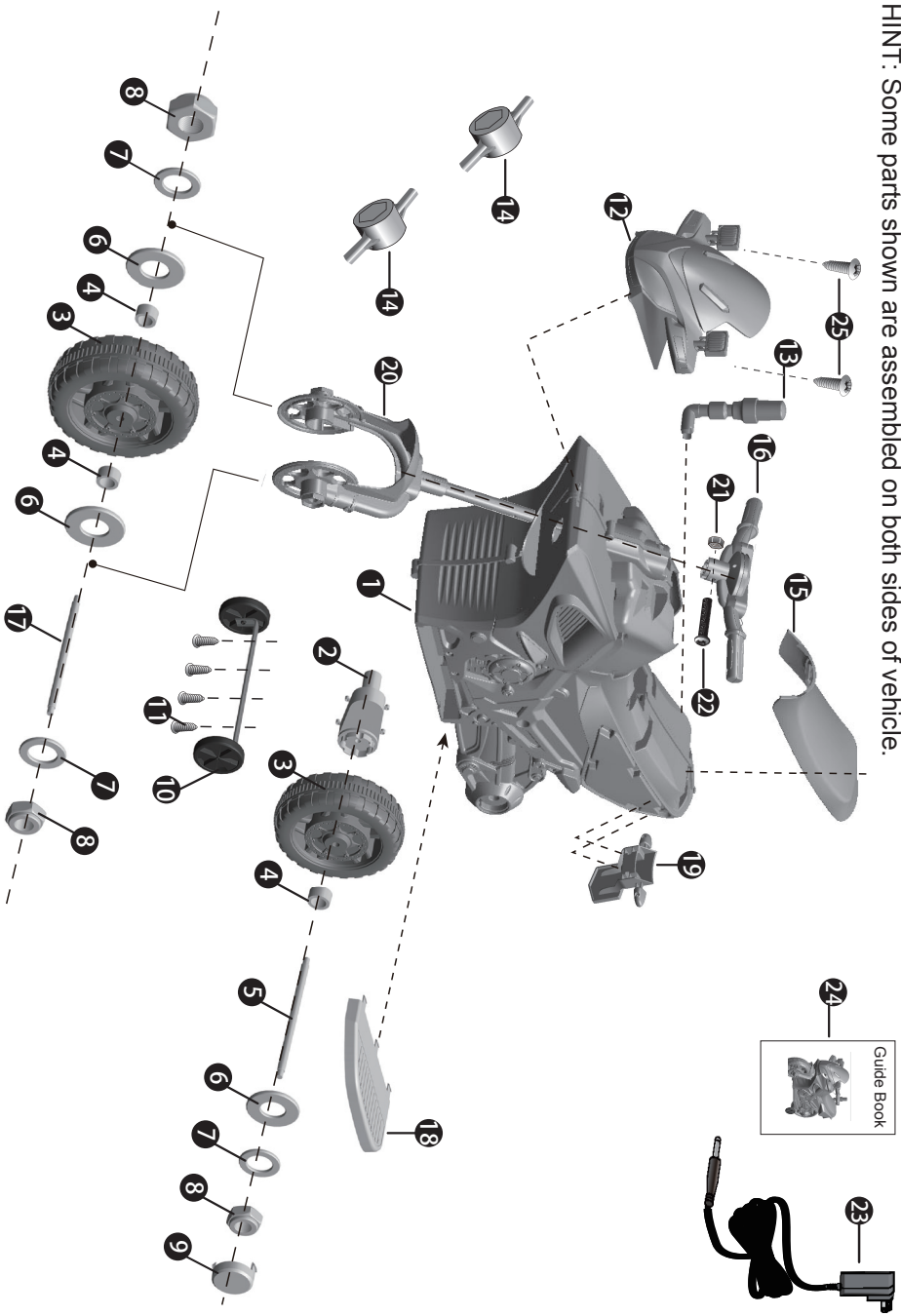

## Assembly

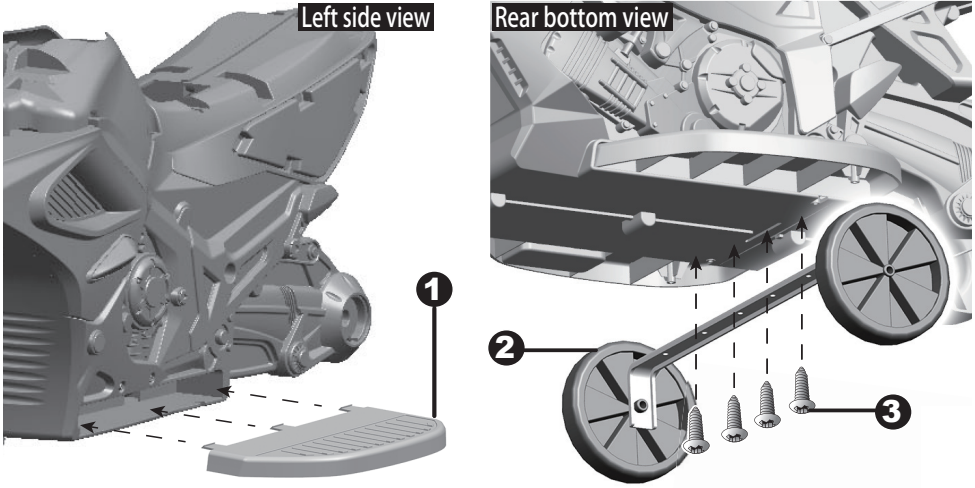

1. Insert the tabs on the foot board into the opening on the left of the vehicle body.
2. Fit the linkage of the side wheel against to the vehicle body.
3. Tighten four  $\Phi 4 \times 16$  truss head screws to secure it.

## Assembly

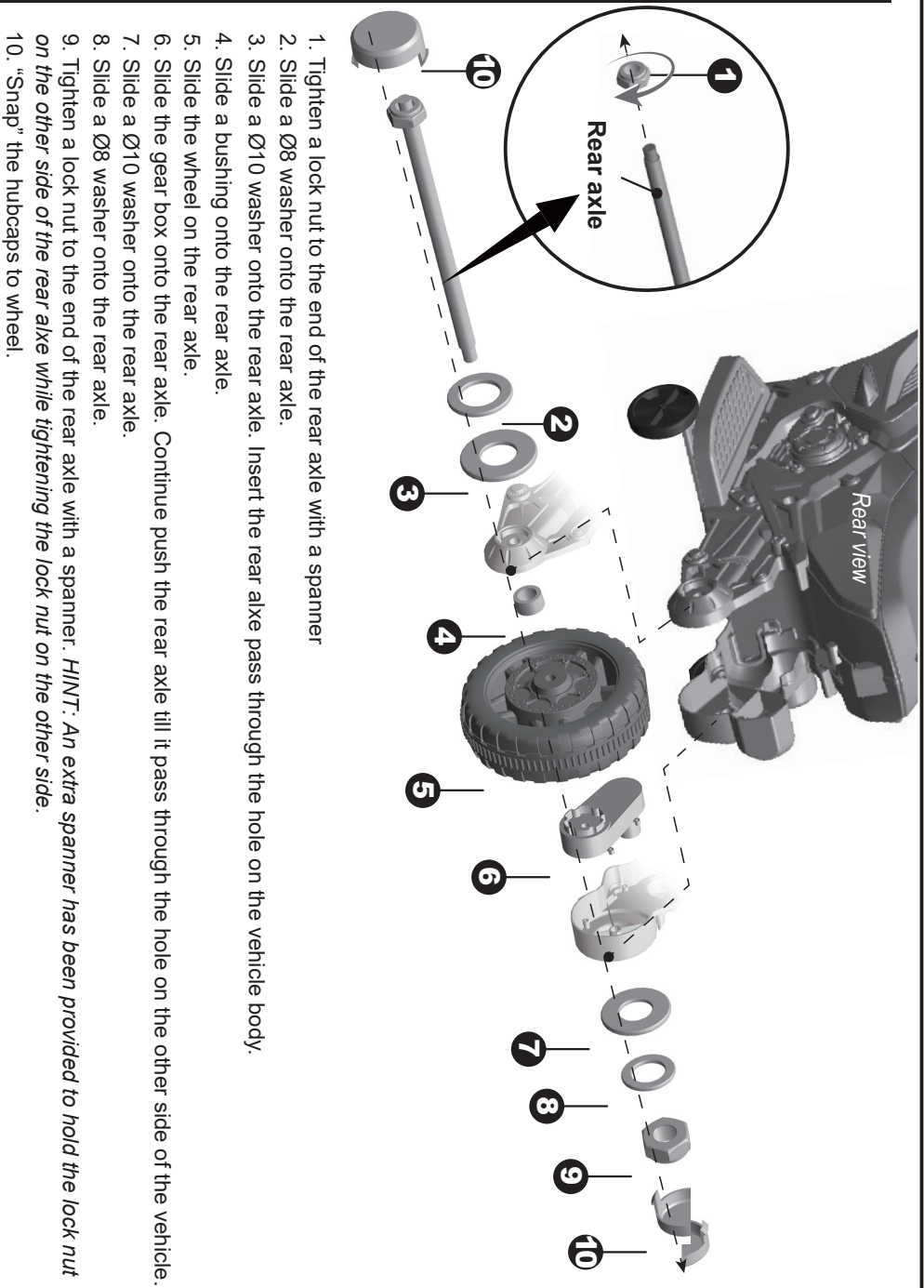



## Assembly

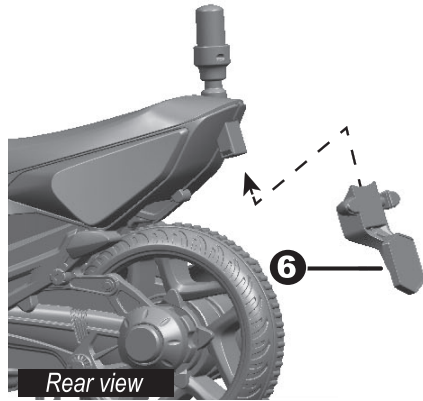
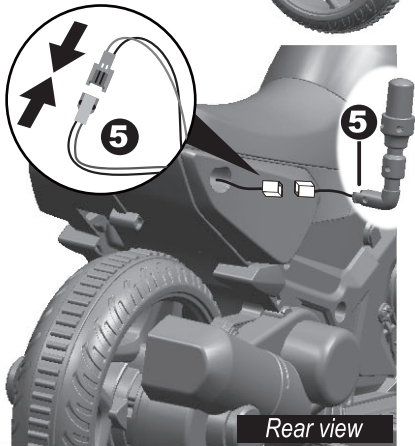
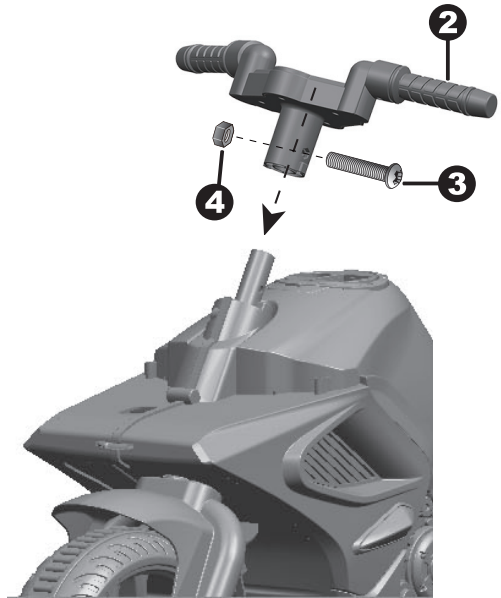
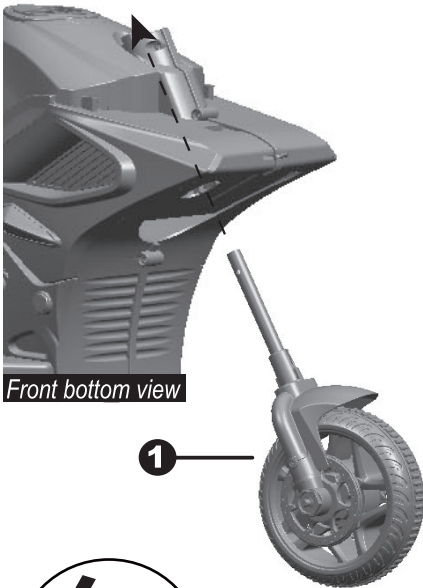

1. Fit the straight end of the front fork into the hole on the front of the vehicle.
2. Fit the handle bar to the front fork.
3. Align the holes on the each side of the handle bar with the holes at the end of front fork.
4. Fasten a  $\Phi 5$  nut on the opposite end of the screw to secure the handle bar.
5. Connect the warning light line and insert it into the car body, then put the warning light into the right place in the hole of the car.
6. Fit the rear number plate to the vehicle.

## Assembly

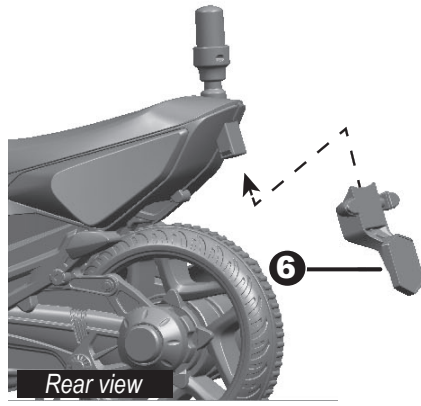
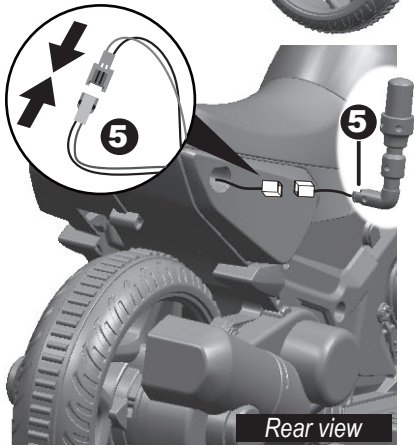
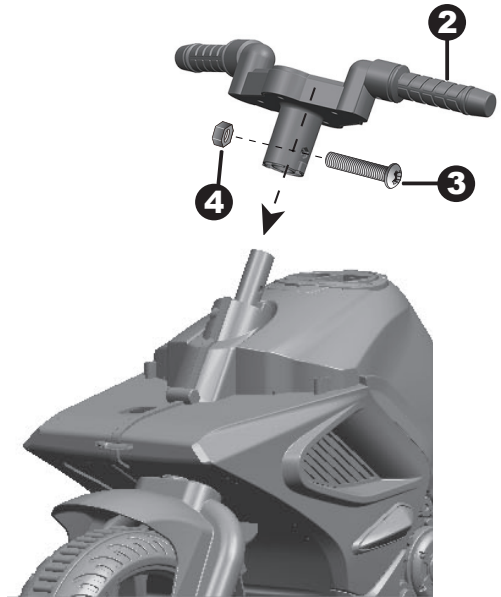
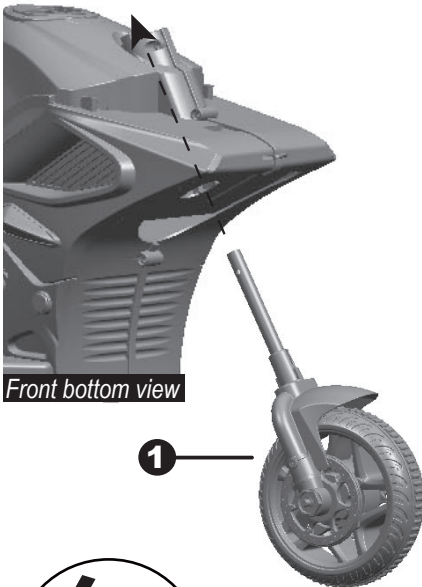

1. Fit the straight end of the front fork into the hole on the front of the vehicle.
2. Fit the handle bar to the front fork.
3. Align the holes on the each side of the handle bar with the holes at the end of front fork.
4. Fasten a  $\Phi 5$  nut on the opposite end of the screw to secure the handle bar.
5. Connect the warning light line and insert it into the car body, then put the warning light into the right place in the hole of the car.
6. Fit the rear number plate to the vehicle.

## Assembly

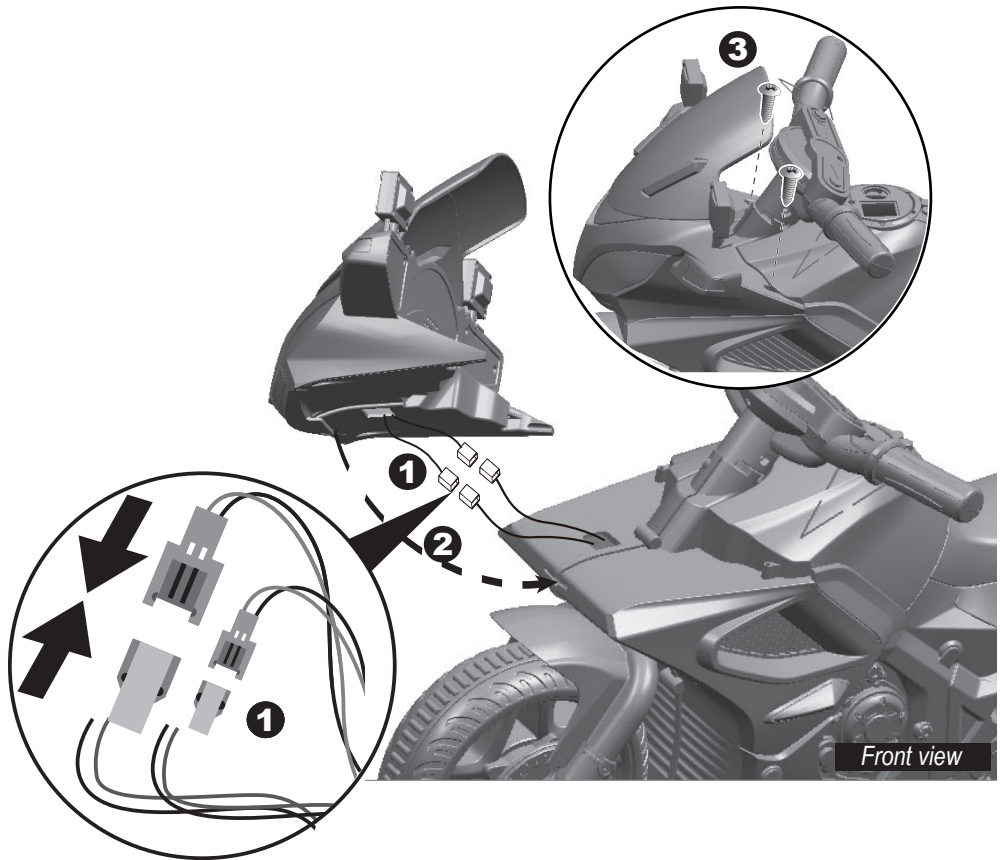

1. Plug the connector on the faceguard into the connector on the vehicle.
2. Insert the tabs on the faceguard into the slots on the front of the vehicle.
3. Insert the two  $\Phi 4 \times 12$  round head screws and tighten them with a screwdriver to secure it.

## Assembly

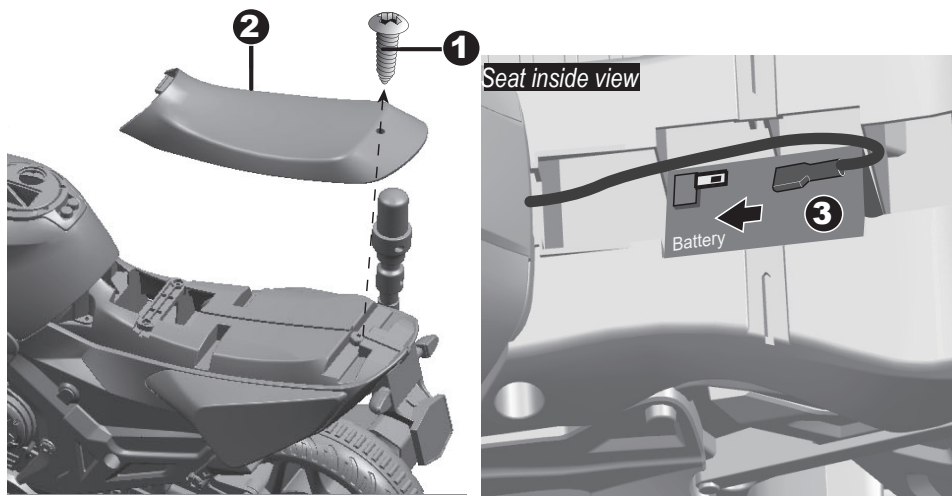

1. Remove the screw on the top of the seat and lift the seat.
2. Replace the seat.
3. Insert the red vehicle connector into the red terminal on the battery.
4. Tighten the screw with a screw-driver.

## Use Your New Ride-on

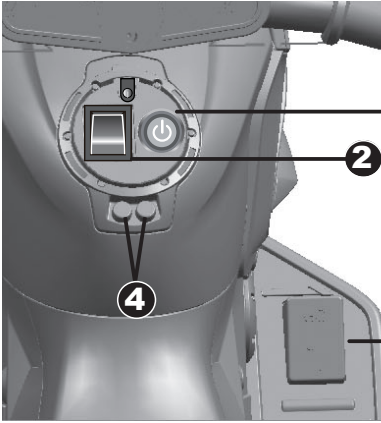

- ① **Power switch:** Turns the vehicle on or off.
- ② **Forward/Reverse switch:** Changes the direction that vehicle moves from forward to reverse. In the middle is stop.
- ③ **Foot pedal switch:** Applies power(speed) to the ride-on.
  - To move the ride-on, press the pedal down.
  - To brake or slow down, release pressure from the pedal.
- ④ **Music switch:** Press these two buttons, music will begin.

## Charging

- The POWER SWITCH must be turned to the **OFF** position when charging.
  - Do not recharge the battery for more than 10 hours to avoid overheating the charger.
  - When the vehicle begins to run slowly, recharge the battery.
  - After each use or once a month minimum recharge time as 8 to 12 hours, less than 20 hours at most.
1. Plug the charger port into the input socket. (right side below the seat)
  2. Plug the charger plug into a wall outlet. The battery will begin charging.

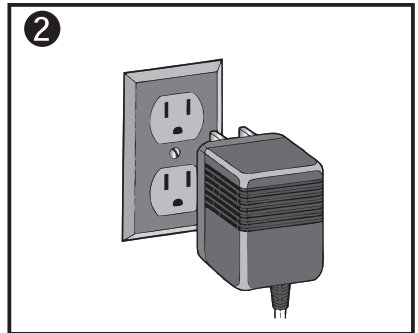
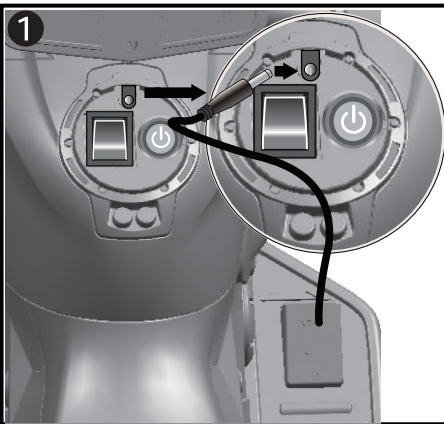

## Troubleshooting Guide

Problem	Possible Cause	Solution
Vehicle does not run	Battery low on power	Recharge battery.
	Thermal fuse has tripped	The fuse will reset automatically in 20 seconds.
	Battery connector or wires are loose	Check that the battery connectors are firmly plugged into each other. If wires are loose around the motor <b>contact your distributor please.</b>
	Battery is dead	Replace battery, <b>contact your distributor please.</b>
	Electrical system is damaged	<b>Contact your distributor please.</b>
	Motor is damaged	<b>Contact your distributor please.</b>
Vehicle does not run very long	Battery is under charged	Check that the battery connectors are firmly plugged into each other when recharging
	Battery is old	Replace battery, <b>contact your distributor please.</b>
Vehicle runs sluggishly	Battery low on power	Recharge battery, <b>contact your distributor please.</b>
	Battery is old	Replace battery, <b>contact your distributor please.</b>
	Vehicle is overload	Reduce weight on vehicle. Maximum user weight is 25 kg.
	Vehicle is being used in harsh conditions	Avoid using vehicle in harsh conditions ,see <Safety>.
Vehicle needs a push to go forward	Poor contact of wires or Connectors	Check that the battery connectors are firmly plugged into each other. If wires are loose around the motor, <b>contact your distributor please.</b>
	“Dead Spot” on motor	A dead spot means the electric power is not being delivered to the terminal connection and the vehicle needs repair. <b>Contact your distributor please.</b>
Difficult shifting from forward to reverse or vice-versa	Attempting to shift while the vehicle is motion	Completely stop the vehicle and shift, see <Use Your New Vehicle>
Loud grinding or clicking noises coming from motor or gear box	Motor or gears are damaged	<b>Contact your distributor please.</b>
Battery will not recharge	Battery connector or adapter connector is loose	Check that the battery connectors are firmly plugged into each other.
	Charger not plugged in	Check that the battery charger is plugged into a working wall outlet.
	Charger is not working	<b>Contact your distributor please.</b>
Charger feels warm when recharging	This is normal and not a cause for concern	

Completely read through this manual and the troubleshooting guide table before calling. If you still need help resolving the problem **Contact your distributor please.**

**US**

If you have any questions, please contact our customer care center.  
Our contact details are below:



001-877-644-9366



[customerservice@aosom.com](mailto:customerservice@aosom.com)

Imported by Aosom LLC

27150 SW Kinsman Rd Wilsonville, OR 97070 USA

Manufactured in Ningbo City, Zhejiang Province, China

MADE IN CHINA