

**EN\_ IMPORTANT, RETAIN FOR FUTURE REFERENCE: READ CAREFULLY.**

**FR\_ IMPORTANT: A LIRE ATTENTIVEMENT ET À CONSERVER POUR CONSULTATION ULTÉRIEURE.**

**ES\_ IMPORTANTE, LEA Y GUARDE PARA FUTURAS REFERENCIAS.**

**PT\_ IMPORTANTE, RETER PARA REFERÊNCIA FUTURA: LEIA ATENTAMENTE.**

**DE\_ WICHTIG! SORGFÄLTIG LESEN UND FÜR SPÄTER NACHSCHLAGEN AUFBEWAHREN.**

**IT\_ IMPORTANTE! CONSERVARE IL PRESENTE MANUALE PER FUTURO RIFERIMENTO E LEGGERLO ATTENTAMENTE.**

EN

**Dear customer,**

Thank you for purchasing this product. So that your appliance serves you well, please read all the instructions in this user's manual. If you have any questions, please contact our customer care center, Our contact details are below:

FR

**Cher client,**

Nous vous remercions d'avoir acheté ce produit. Afin que vous puissiez profiter pleinement de votre appareil, veuillez lire toutes les instructions de ce manuel d'utilisation. Si vous avez la moindre question, veuillez contacter notre centre d'assistance à la clientèle, Nos coordonnées sont les suivantes:

DE

**Sehr geehrter Kunde,**

Vielen Dank, dass Sie dieses Produkt erworben haben. Damit Ihr Gerät Ihnen gute Dienste leistet, lesen Sie bitte alle Hinweise in diesem Benutzerhandbuch. Wenn Sie Fragen haben, wenden Sie sich bitte an unser Kundendienstzentrum, Unsere Kontaktdaten stehen unten:

ES

**Queridos clientes,**

Gracias por comprar este producto. Para que su electrodoméstico le sirva mejor, lea todas las instrucciones de este manual del usuario. Si tiene alguna pregunta, comuníquese con nuestro Centro de Atención al Cliente, Nuestros datos de contacto son los siguientes:

PT



**Caros clientes,**

Obrigado por adquirir este produto. Para que o seu aparelho o sirva melhor, leia todas as instruções deste manual do utilizador. Se tiver alguma dúvida, por favor contacte o nosso Centro de Atendimento ao Cliente, Os nossos dados de contacto são os seguintes:

IT











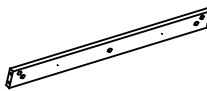
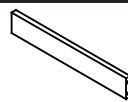

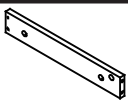
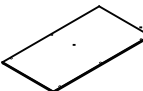

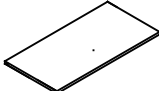
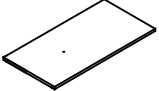
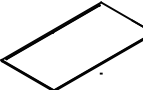
**Caro Cliente,**

Grazie per aver acquistato questo prodotto. Per servirti meglio con questo apparecchio ti prego di leggere tutte le istruzioni in presente manuale utente. In caso di dubbio, si prega di contattare il nostro centro assistenza clienti, I nostri dettagli di contatto sono di seguito:

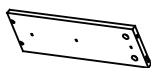
Country	 Phone	 Email
US	001-877-644-9366	customerservice@aosom.com
CA	416-792-6088	customerservice@aosom.ca
UK	0044-800-240-4004	enquiries@mhstar.co.uk
DE	0049-0(40)-88307530	service@aosom.de
FR	0033-1-84166106	aosom@mhfrance.fr
ES	0034-931294512	atencioncliente@aosom.es
PT	0034-931294512	info@aosom.pt
IT	0039-0249471447	clienti@aosom.it

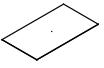
# PACKING DETAILS: TOTAL 2 BOXES



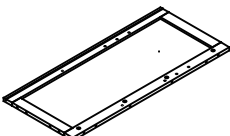
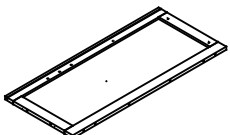
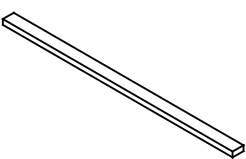
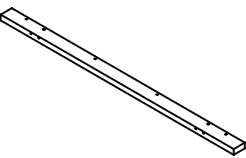
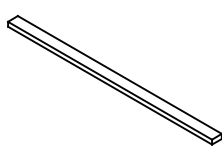
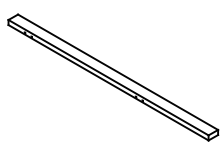
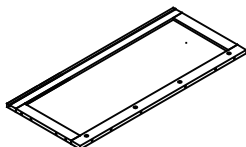
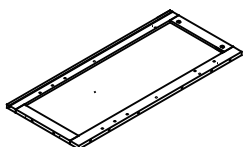
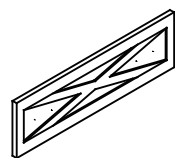

## BOX-1/2

NO.	PARTS	QTY
1		2
2		2
3		2
4		2
5		1
6		1
10		2
11		2
12		1
13		1
14		1
18		1
26		1
29		1
30		1
31		1
32		1
33		1

## BOX-2/2

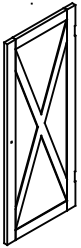
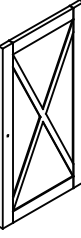
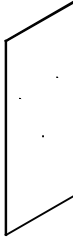
NO.	PARTS	QTY
7		1
8		1
9		1
15		1
16		1
17		1
19		1
20		1
27		1

## BOX-2/2

NO.	PARTS	QTY
21		2
22		2
23		2
24		2
25		2
28		1



Hardware Kit

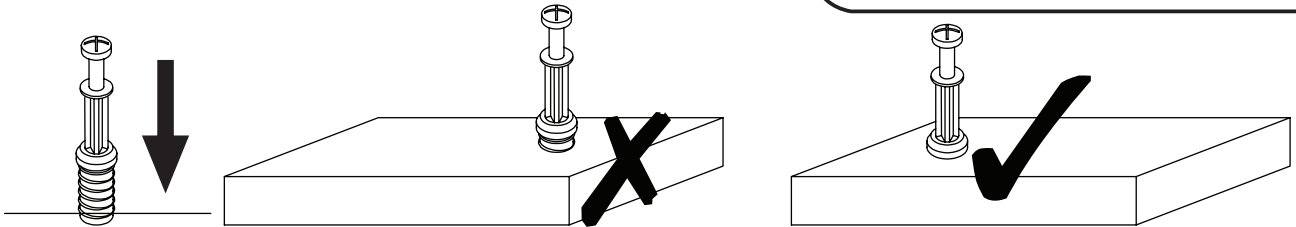

**EN\_QUICKFIT:** Tighten quickfit until shoulder is flush with panel. Do not overtighten or undertighten.

**FR\_RACCORD RAPIDE:** Faites serrer le raccord rapide jusqu'à ce que l'épaulement soit parfaitement encastré dans le panneau. Il ne faut ni trop serrer ni insuffisamment serrer.

**ES\_QUICKFIT:** Apriete quickfit hasta que el hombro se descargue con el panel. NO lo sobreapriete ni lo apriete poco.

**PT\_AJUSTE RÁPIDO:** Aperte o ajuste rápido até estar nivelada com o painel. Não apertar demasiado ou excessivamente.

**DE\_QUICKFIT:** Ziehen Sie den Quickfit fest, bis die Schulter mit der Platte bündig ist. Bitte nicht zu fest oder zu schwach anziehen.

**IT\_MONTAGGIO RAPIDO:** Stringere il montaggio rapido fino a quando la spalla è a filo con il pannello, non stringere troppo o troppo poco.

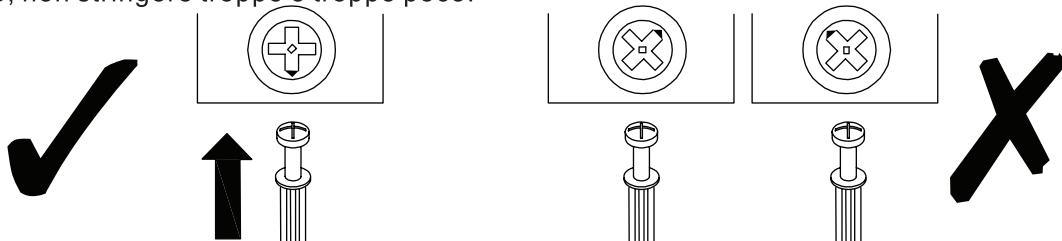

**EN\_CAM LOCK:** When fitting cam lock, ensure starting position is correct before you insert connecting quickfit.

**FR\_SERRURE BATTEUSE:** Avant d'insérer la serrure batteuse, veillez à la bonne orientation avant d'insérer le raccord rapide.

**ES\_CIERRE DE LA CÁMARA:** Cuando instale el cierre de la cámara, asegúrese de que la posición de inicio es correcta antes de que inserte el quickfit conector.

**PT\_BLOQUEIO:** Ao instalar o bloqueio, assegurar-se de que a posição inicial está correcta antes de inserir o encaixe de ligação rápida.

**DE\_CAM-LOCK:** Achten Sie bei der Montage des Cam-Locks auf die richtige Ausgangsposition, bevor Sie den Quickfit einsetzen.

**IT\_BLOCCAGGIO A CAMMA:** Quando si monta il bloccaggio a camma, assicurarsi che la posizione iniziale sia corretta prima di inserire il montaggio rapido di collegamento.

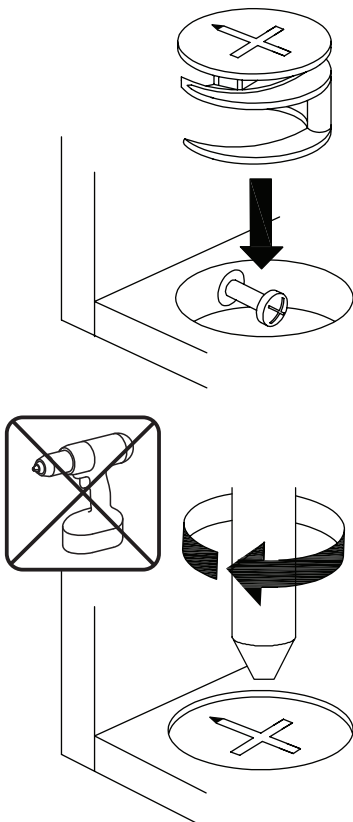

**EN\_Quickfit head** should be in the centre of the cam lock when the two panels are joined.

Cam lock should be inserted before quickfit.

**FR\_**Lorsque les deux panneaux sont assemblés, la tête du raccord rapide doit reposer au centre de la serrure batteuse.

Il faut insérer la serrure batteuse avant le raccord rapide.

**ES\_**El cabezal del quickfit debe estar en el centro del cierre de la cámara cuando se unan los dos paneles.

Se debe insertar el cierre de la cámara antes que el quickfit.

**PT\_**A cabeça de ajuste rápido deve estar no centro da fechadura quando os dois painéis estão unidos.

A fechadura de cammas deve ser inserida antes de ser rápida.

**DE\_**Der Quickfit-Kopf sollte sich in der Mitte des Cam-Locks befinden, wenn die beiden Platten zusammengefügt sind.

Der Cam-Lock sollte vor dem Quickfit eingesetzt werden.

**IT\_**La testa del montaggio rapido deve trovarsi al centro del bloccaggio a camma quando i due pannelli sono uniti.

Il Bloccaggio a Camma deve essere inserito prima del montaggio rapido.

**EN\_**Turn cam lock clockwise to tighten.

**FR\_**Faites tourner la serrure batteuse dans le sens des aiguilles d'une montre pour la resserrer.

**ES\_**Gire el cierre de la cámara en sentido horario para apretarlo.

**PT\_**Rodar o bloqueio no sentido dos ponteiros do relógio para o apertar.

**DE\_**Drehen Sie den Cam-Lock im Uhrzeigersinn, um ihn festzuziehen.

**IT\_**Ruotare il bloccaggio a camma in senso orario per stringere.

**EN\_NOTE:** Pull inner and outer drawer runners apart before fixing them to panels.

**FR\_REMARQUE:** Avant de fixer les glissières de tiroir aux panneaux, tirez vers l'extérieur et poussez vers l'intérieur de chacun des tiroirs.

**ES\_NOTA:** retire los rieles interiores y exteriores antes de fijarlos a los paneles.

**PT\_NOTA:** Separar as corrediças das gavetas interiores e exteriores antes de fixar para os painéis.

**DE\_HINWEIS:** Ziehen Sie die inneren und äußeren Schubladenführung auseinander, bevor Sie sie an den Platten befestigen.

**IT\_NOTA:** Separare le guide interne ed esterne del cassetto prima di fissarle ai pannelli.

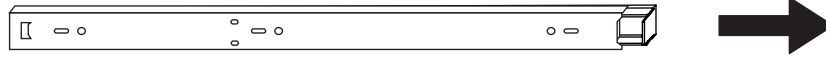

**EN\_Slide** drawer runners apart until the drawer lock can be seen, as shown.

**FR\_Les** glissières de tiroir doivent être ouvertes jusqu'à ce que la serrure du tiroir soit visible, comme indiqué.

**ES\_Deslice** a un lado los rieles del cajón hasta que se pueda ver el cierre del armario, tal y como se muestra.

**PT\_Deslizam-se** as gavetas até?se poder ver o fecho da gaveta, como se mostra.

**DE\_Schieben** Sie die Schubladenführungen auseinander, bis das Schubladenschloss sichtbar ist, gemäß der Abbildung.

**IT\_Far** scorrere le guide del cassetto fino a quando non sia visibile il blocco di scorrimento, come mostrato.

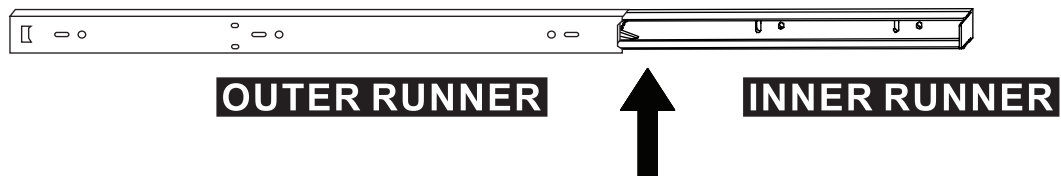

**EN\_Press** and hold the drawer runner lock and then continue to slide drawer runners apart, as shown.

**FR\_En** appuyant et en maintenant le verrouillage des glissières de tiroir, vous pouvez continuer à les écarter l'une de l'autre, comme indiqué.

**ES\_Mantenga** presionado el cierre del riel del cajón y después continúe deslizando a un lado los rieles de los cajones, tal y como se muestra.

**PT\_Manter** pressionado o fecho de gaveta e depois continuar a deslizar as corrediças da gaveta, como mostrado.

**DE\_Drücken** und halten Sie die Verriegelung der Schubladenführung und schieben Sie die Schubladenführungen wie abgebildet weiter auseinander.

**IT\_Tenere** premuto il blocco di scorrimento e quindi continuare a far scorrere la guida, come mostrato.

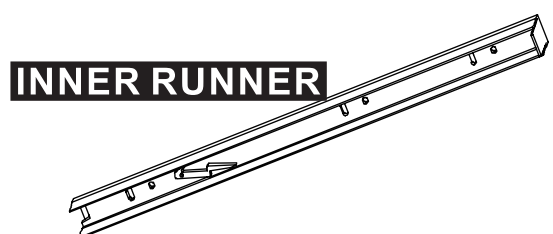
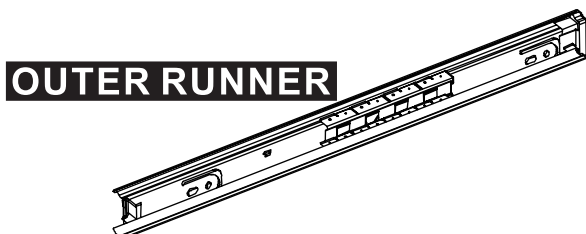
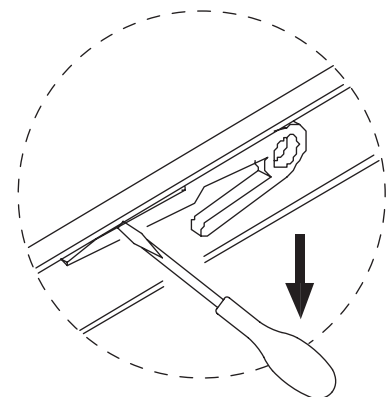

**EN\_Your** inner and outer drawer runners are ready to be fixed to panels.

**FR\_Il** est possible, à présent, de fixer les glissières intérieures et extérieures de vos tiroirs sur des panneaux.









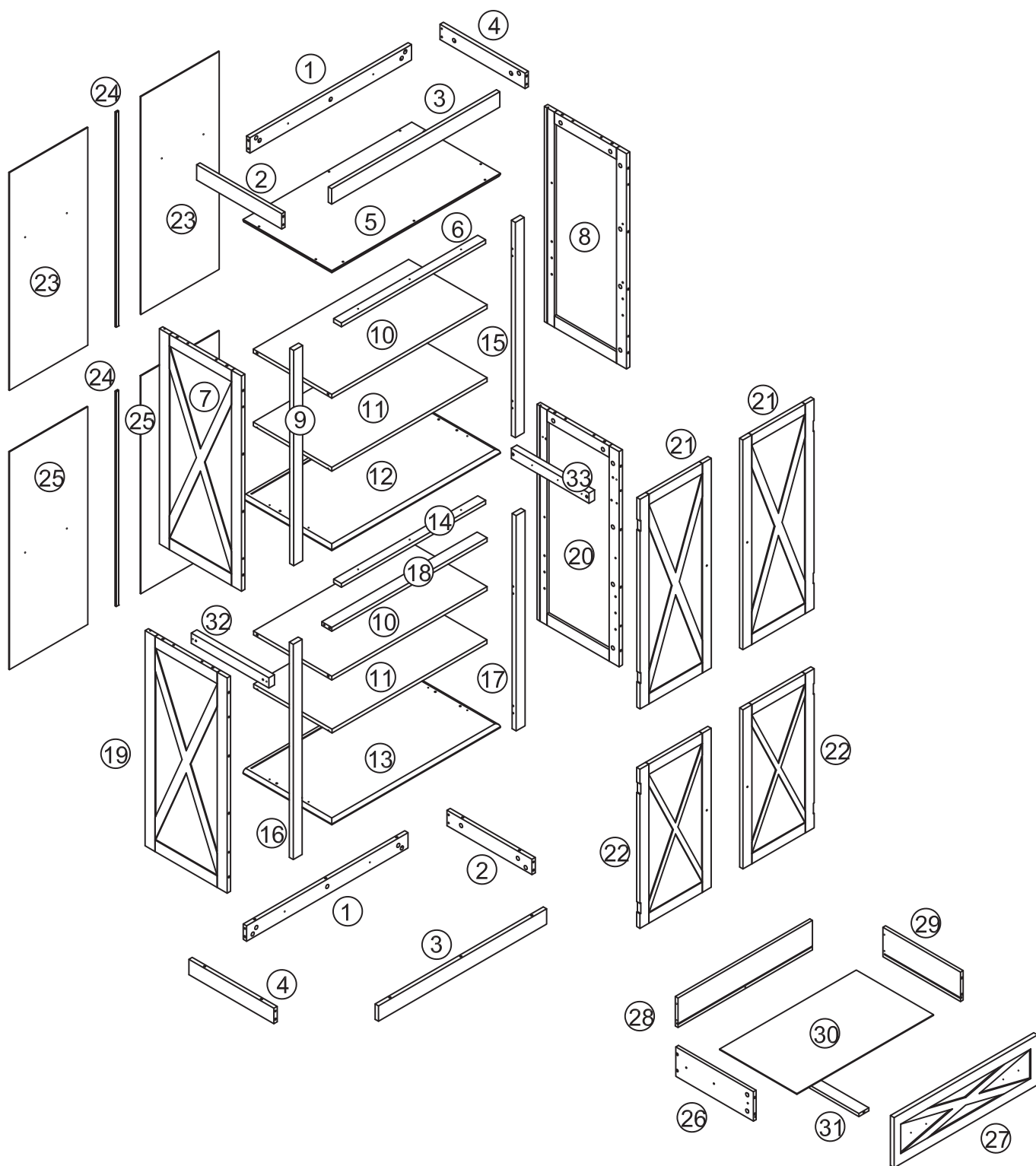



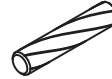







**ES\_Los** rieles interiores y exteriores del cajón están listos para fijarse a los paneles.

**PT\_As** corrediças das gavetas interiores e exteriores estão prontas para serem fixadas nos painéis.

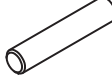
**DE\_Ihre** inneren und äußeren Schubladenführungen sind bereit, an den Platten befestigt zu werden.

**IT\_Le** guide interne ed esterne sono pronte per essere fissate ai pannelli.

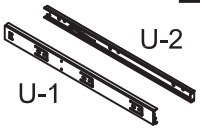

	<b>A</b> x67 M6*35 +2(spare)		<b>B</b> x67 +2(spare)		<b>C</b> x30 M6*30 +2(spare)		<b>D</b> x9 M4*30
	<b>E</b> x8 M5*45		<b>F</b> x6 M4*25		<b>G</b> x2 M4*45		<b>H</b> x4 M4*16
	<b>I</b> x4		<b>J</b> x2		<b>K</b> x52 M3*14 +2(spare)		<b>L</b> x4
	<b>M</b> x24 +1(spare)		<b>N</b> x36 M3*12 +2(spare)		<b>O</b> x8		<b>P</b> x8
	<b>Q</b> x2		<b>R</b> x8 M3*14		<b>S</b> x8		<b>T</b> x2
	<b>U</b> x2 U-2 U-1		<b>V</b> x4 M6*50				

**EN\_** Do not confuse similar screws. Do not tighten bolts fully until all parts are connected!

**FR\_** Ne pas confondre des vis similaires. Ne serrez pas les boulons à fond tant que toutes les pièces ne sont pas connectées!

**ES\_** No confunda tornillos similares. No apriete los tornillos completamente hasta que todas las partes están conectadas!

**PT\_** Não confundir parafusos semelhantes. Não apertar completamente os parafusos até que todas as peças estejam encaixadas!

**DE\_** Verwechseln Sie ähnliche Schrauben nicht. Ziehen Sie die Schrauben erst fest an, wenn alle Teile verbunden sind!

**IT\_** Non confondere le viti simili. non serrare completamente i bulloni fino a tutte le parti non sono ancora collegate!

**NOTE**

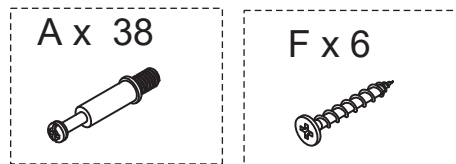
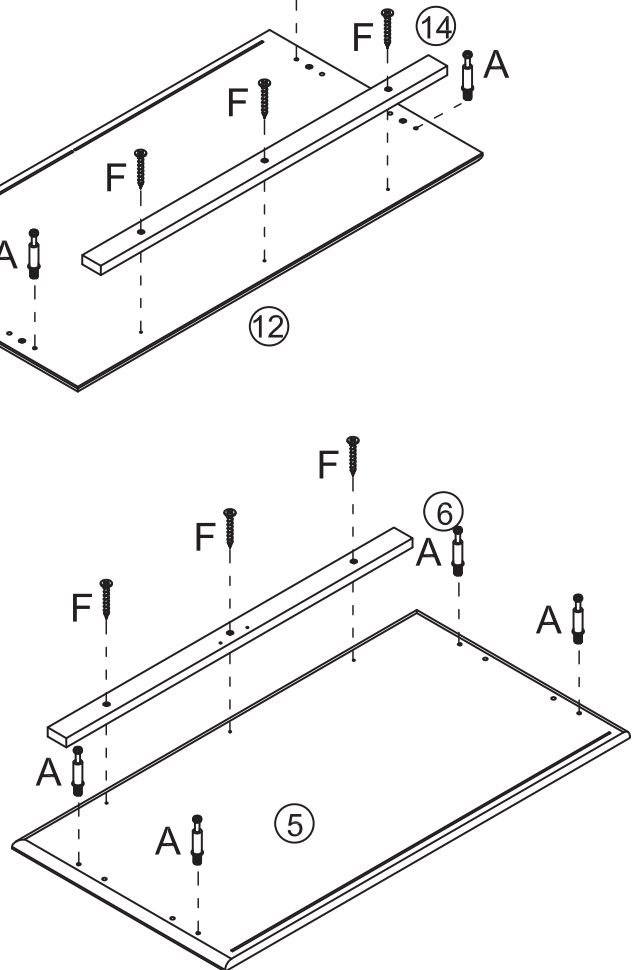
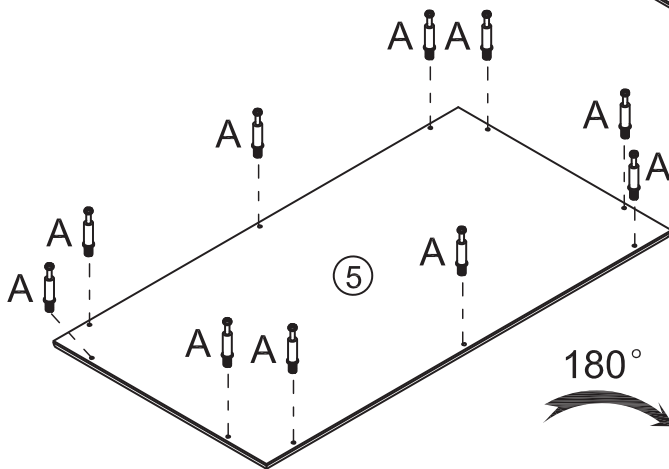
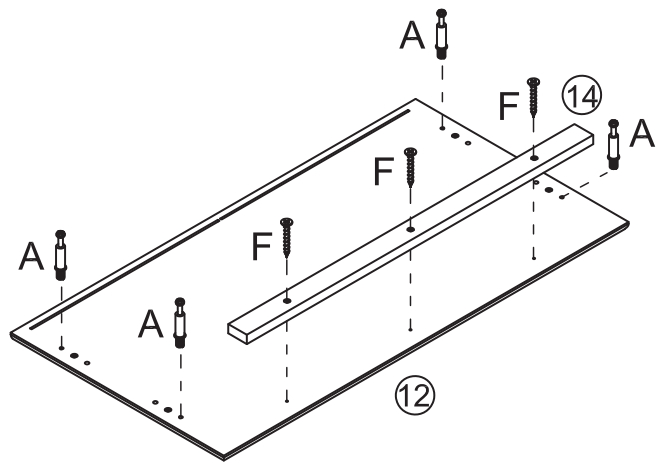
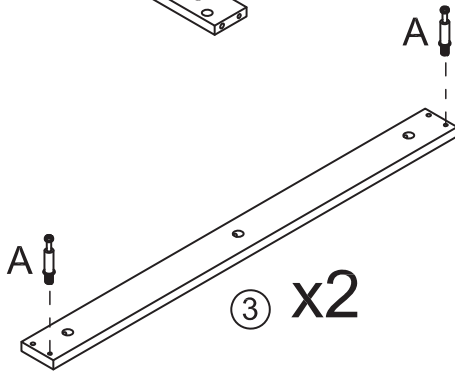
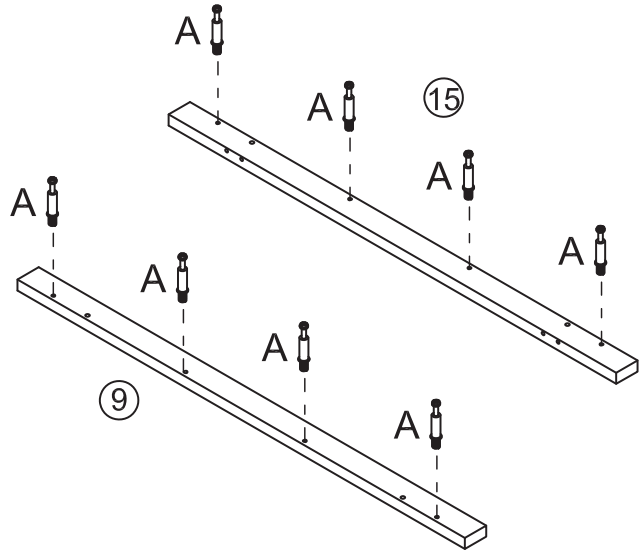
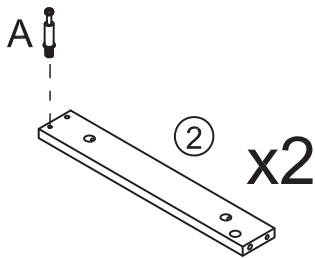
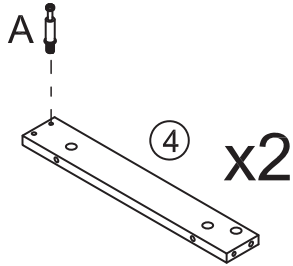
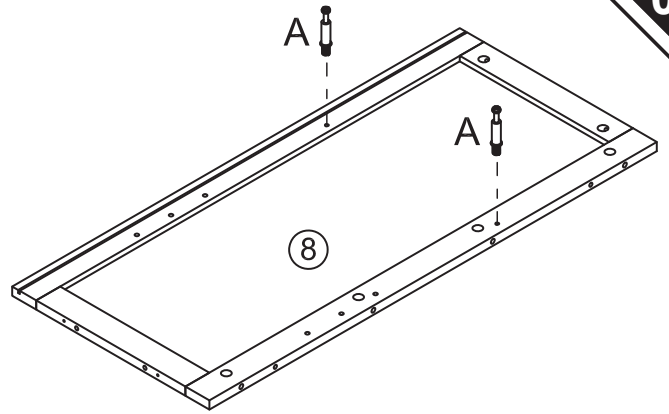
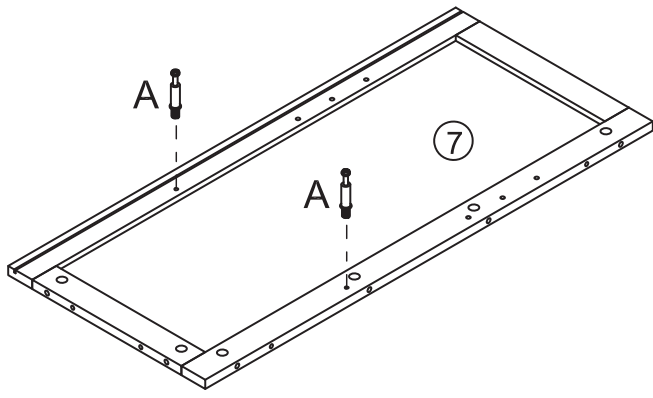



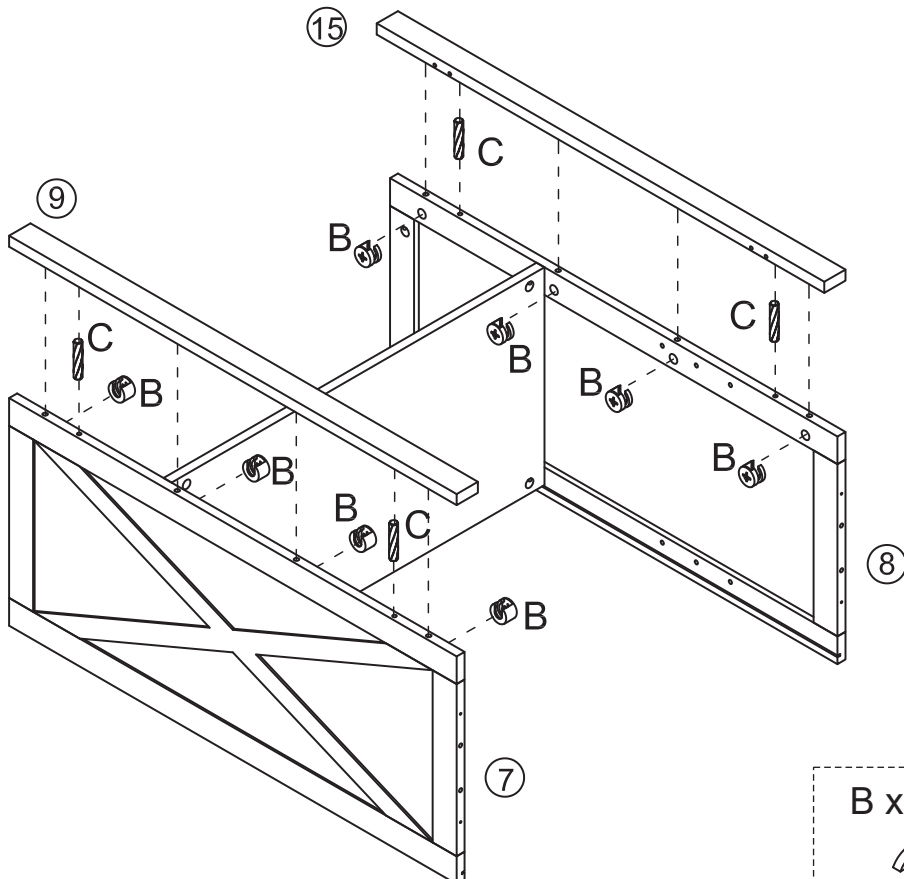
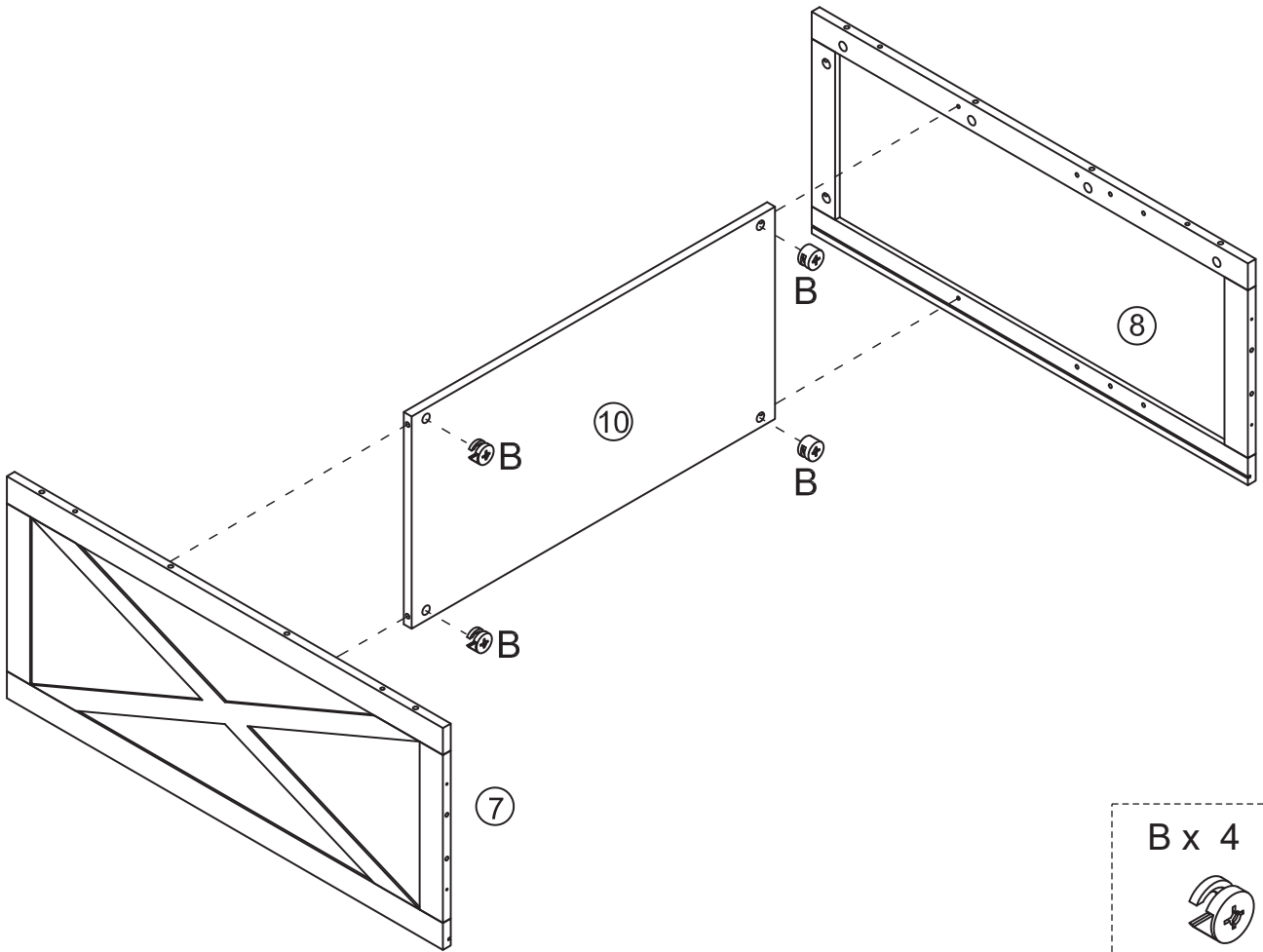

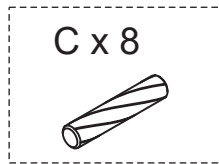
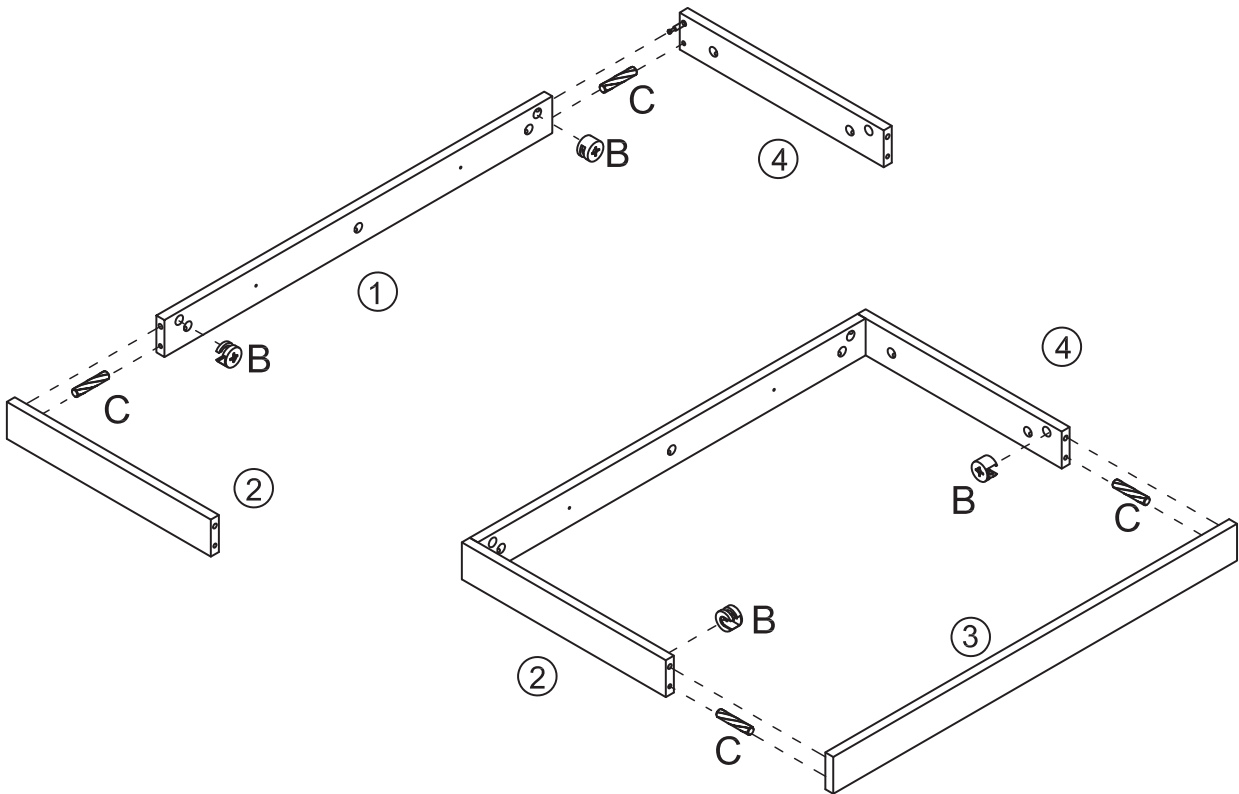
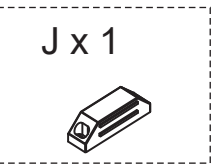
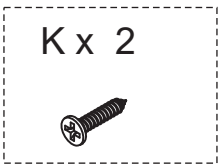
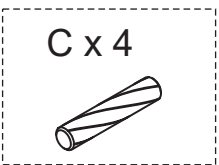
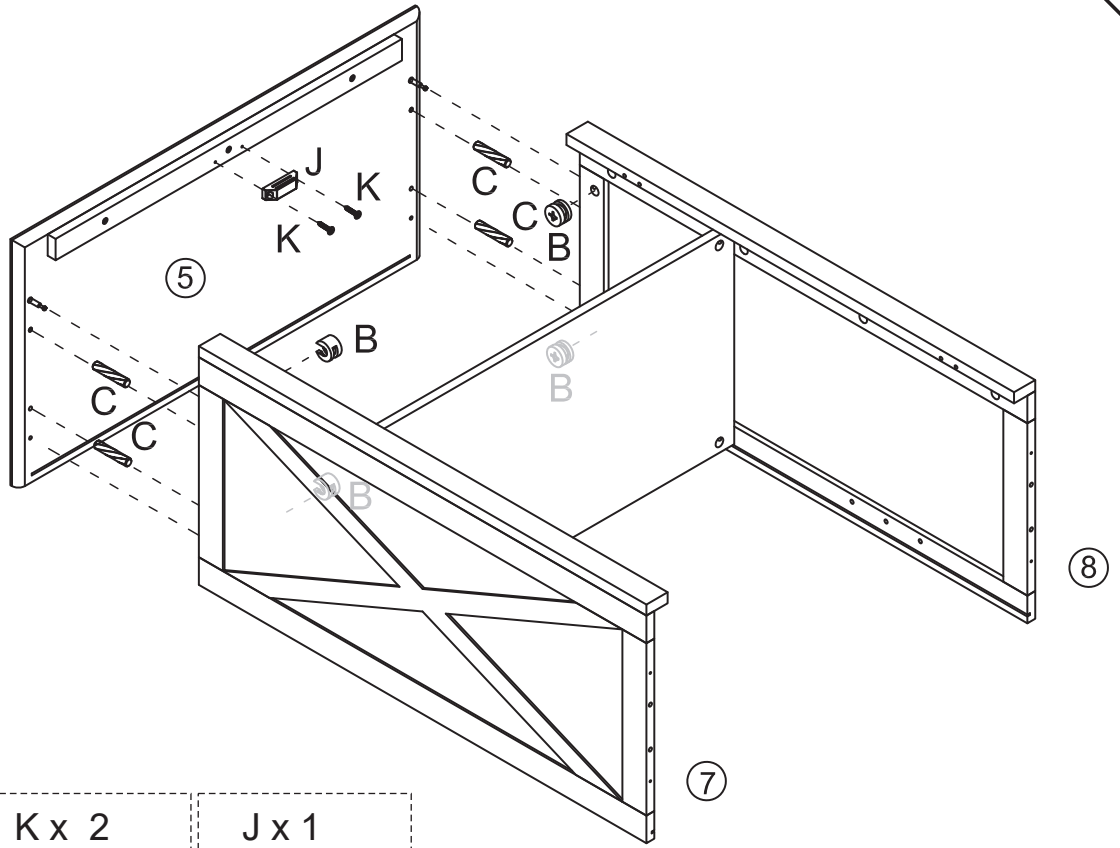

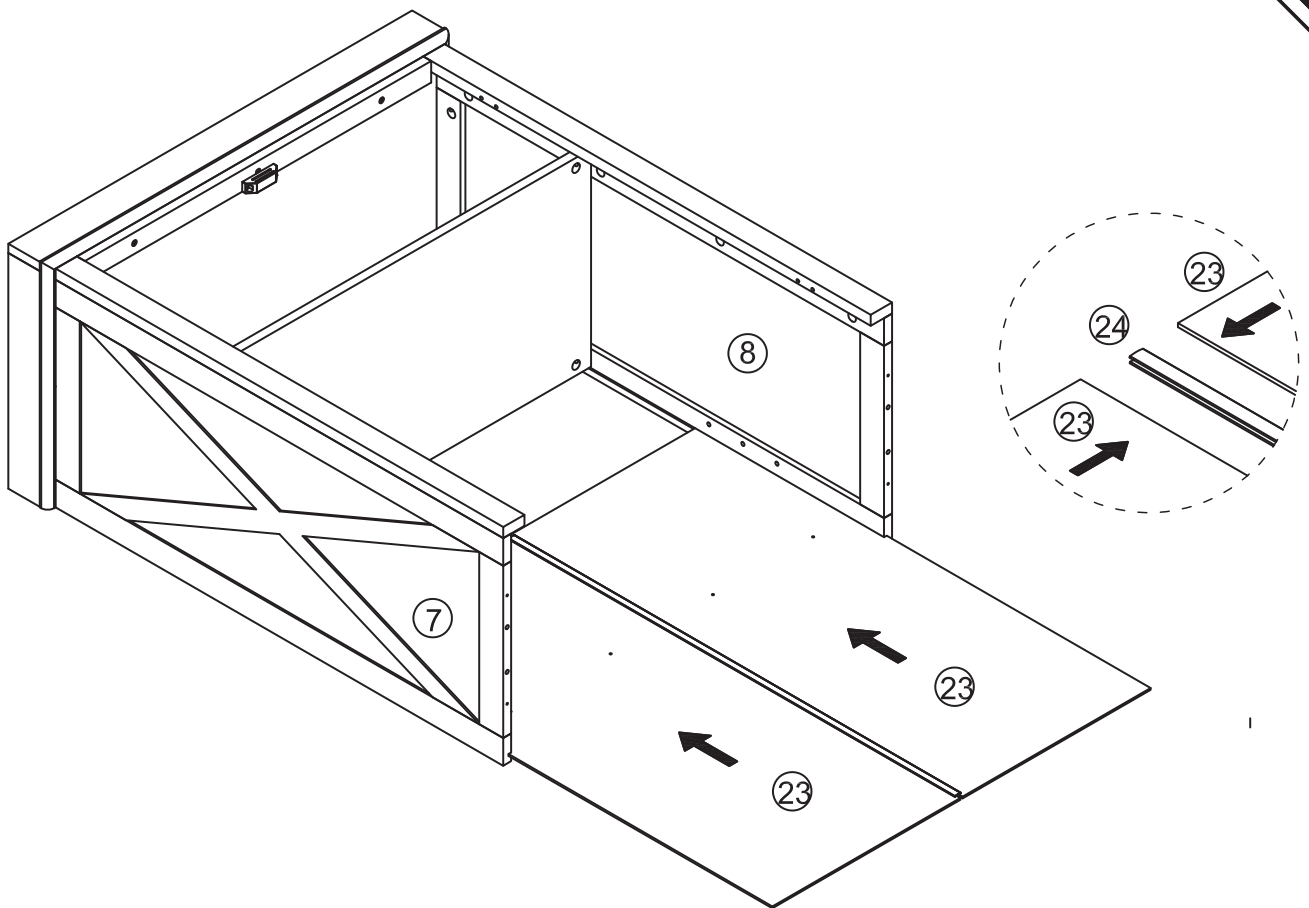
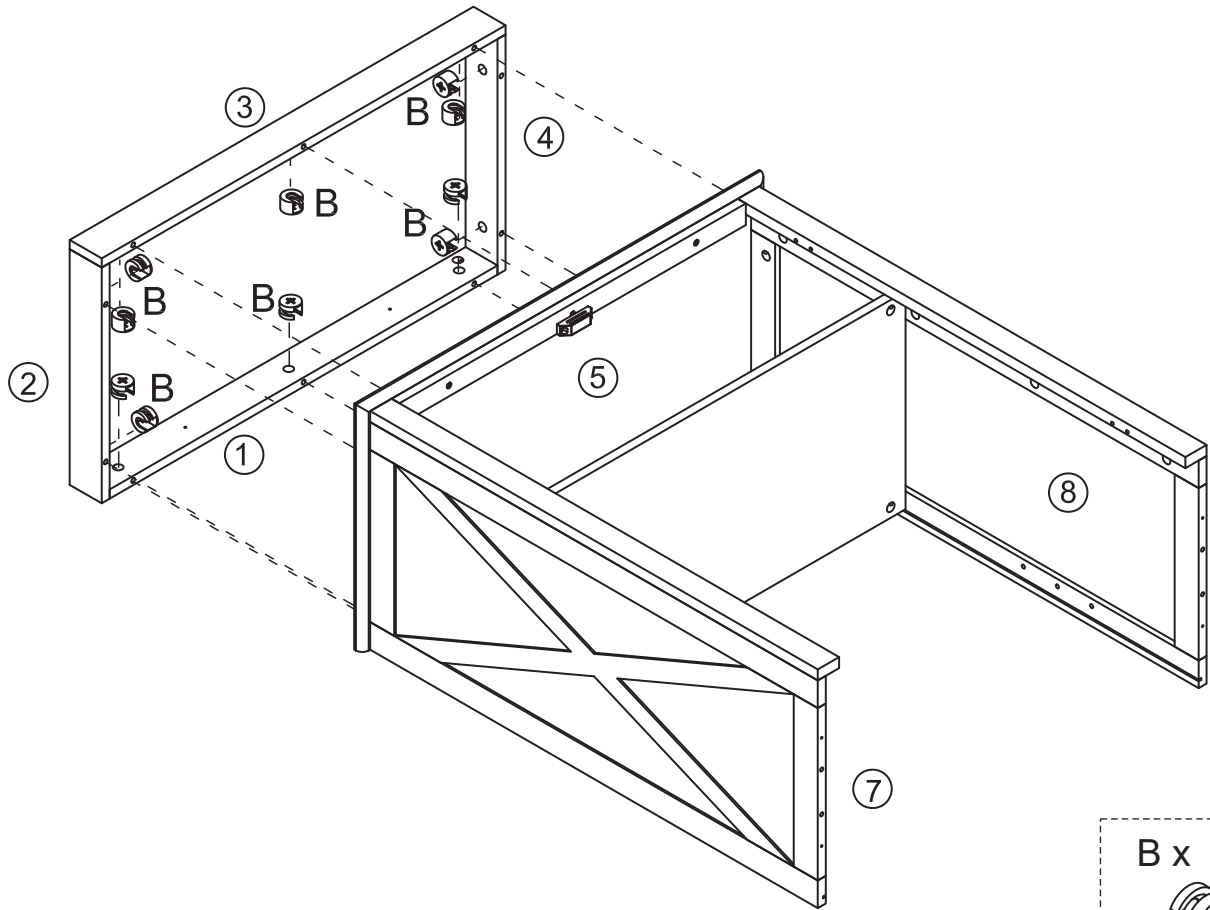

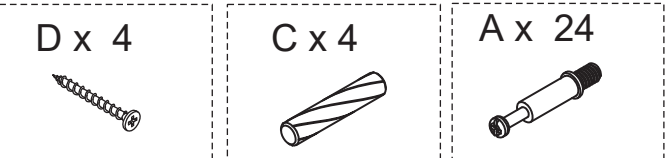
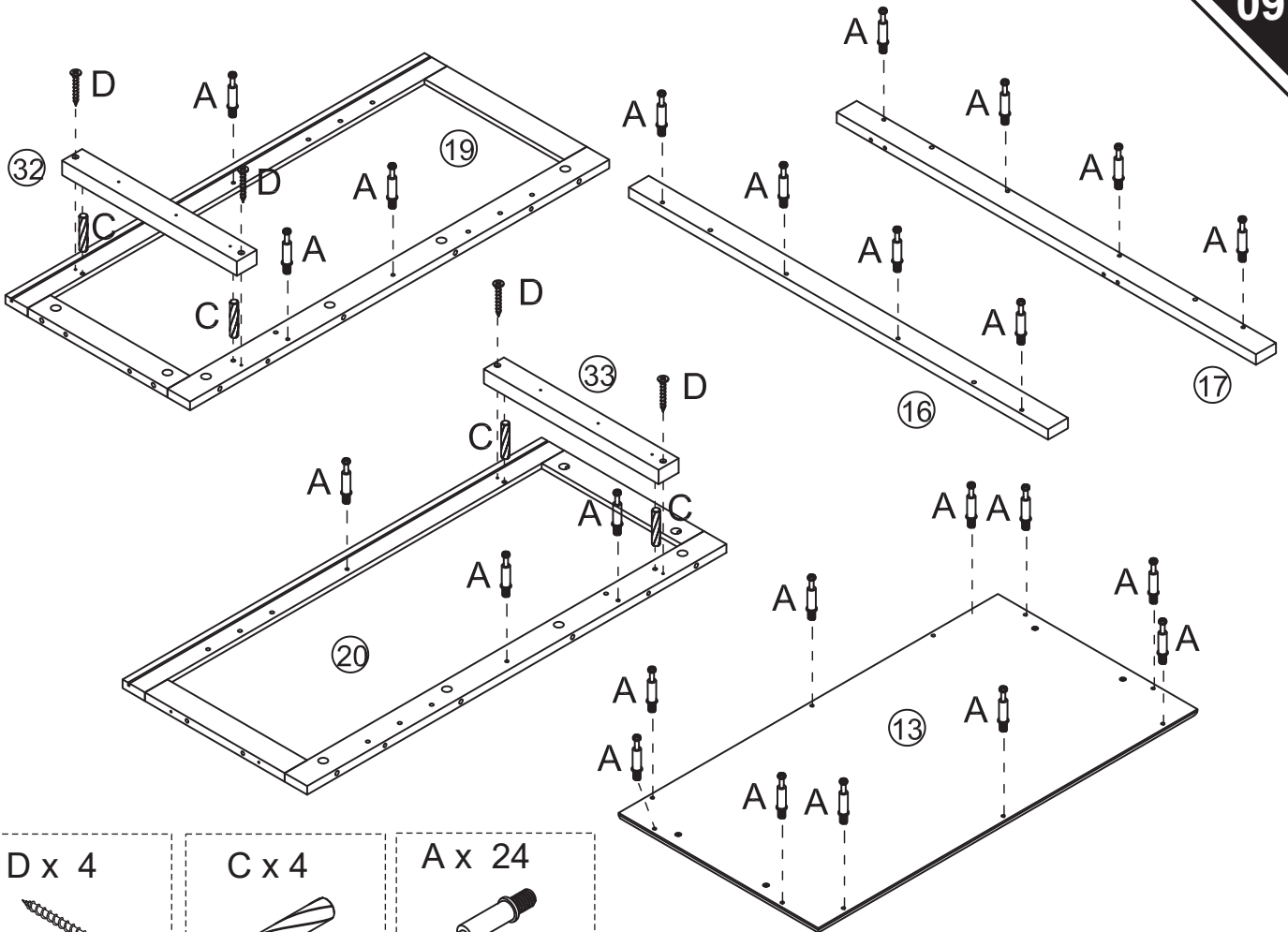
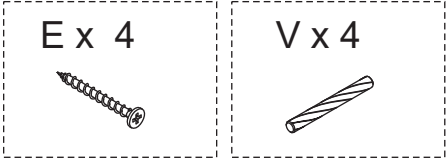
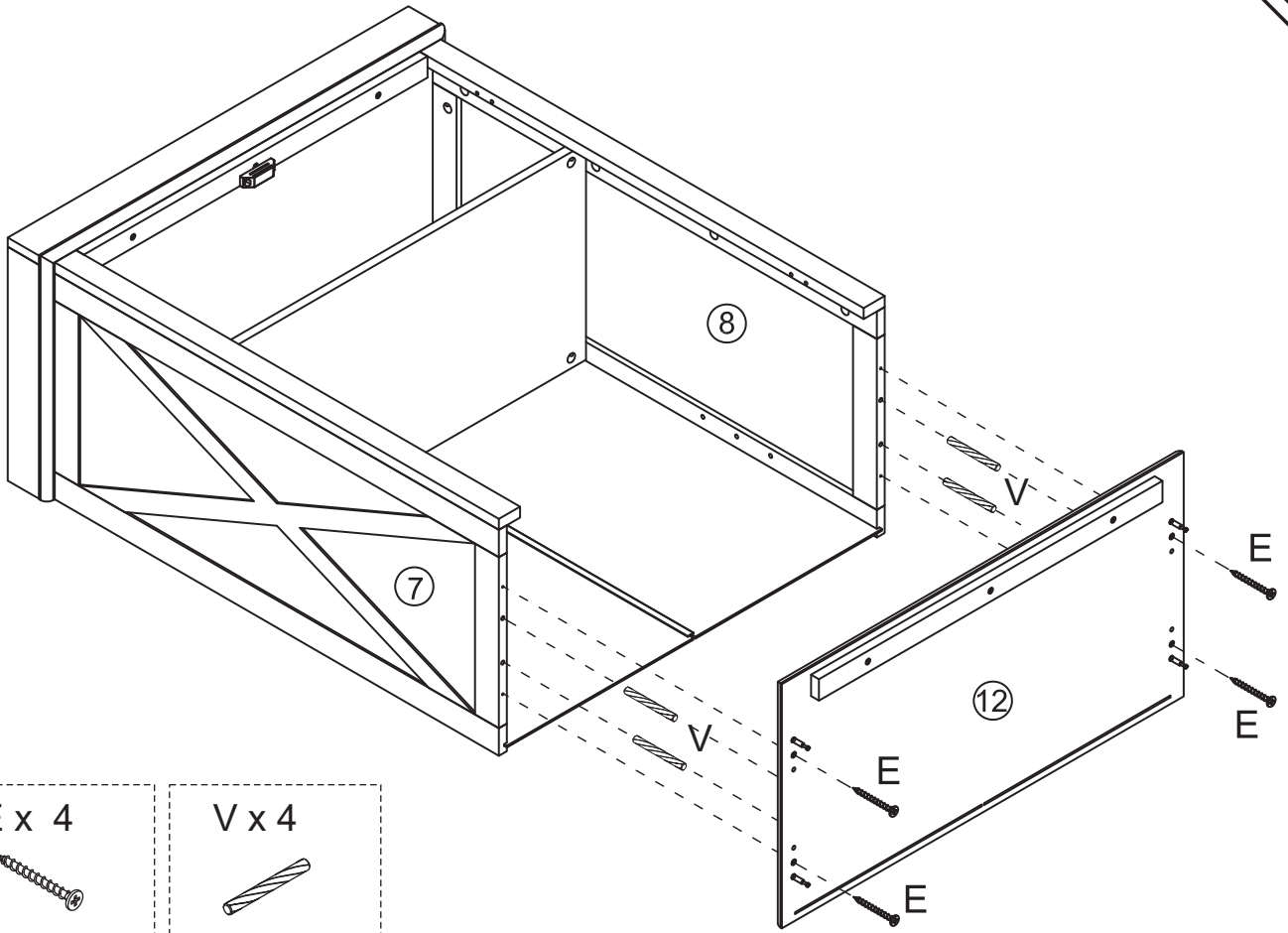

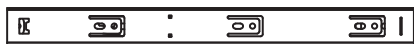

U-1



U-1

U-2



U-1

U-2



U-1

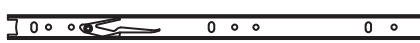

U-2

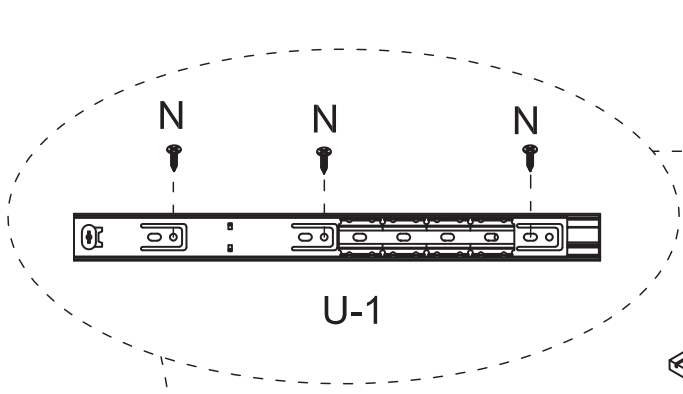
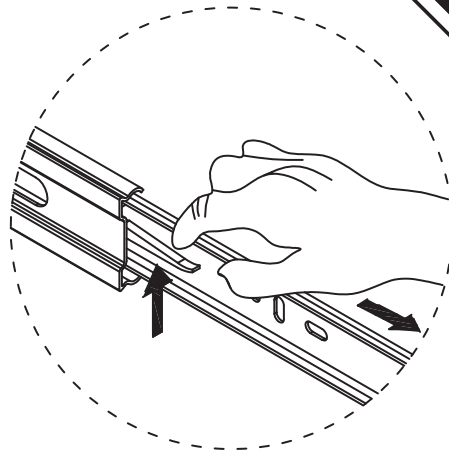

U-1

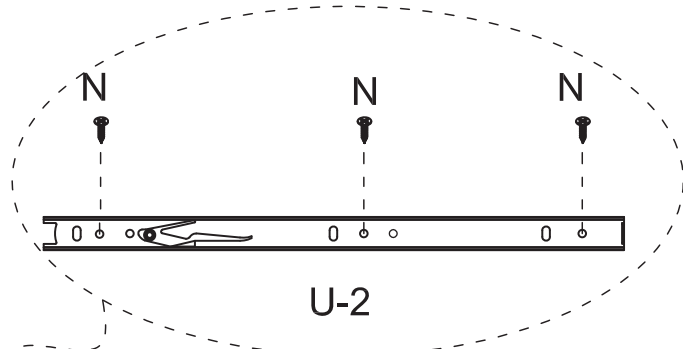
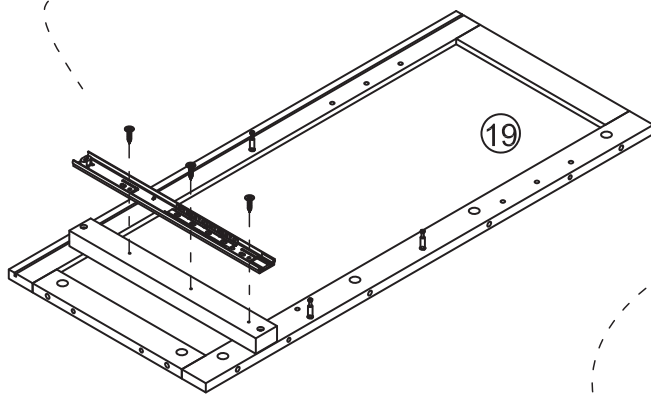
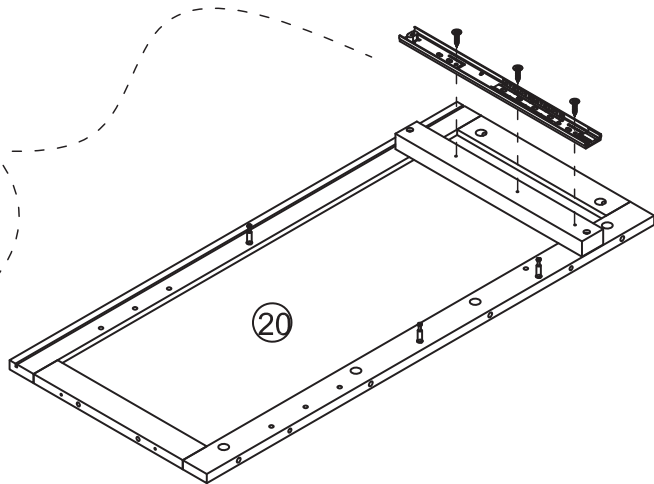

U-2

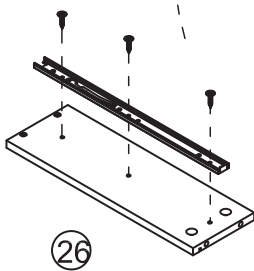

26

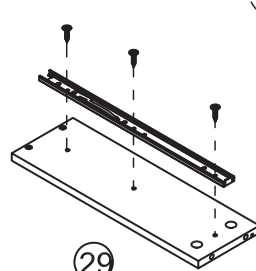

29

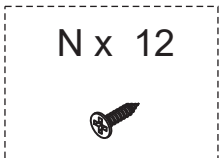
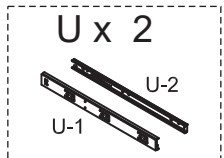

J x 1



B x 6



C x 2

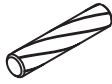

K x 2

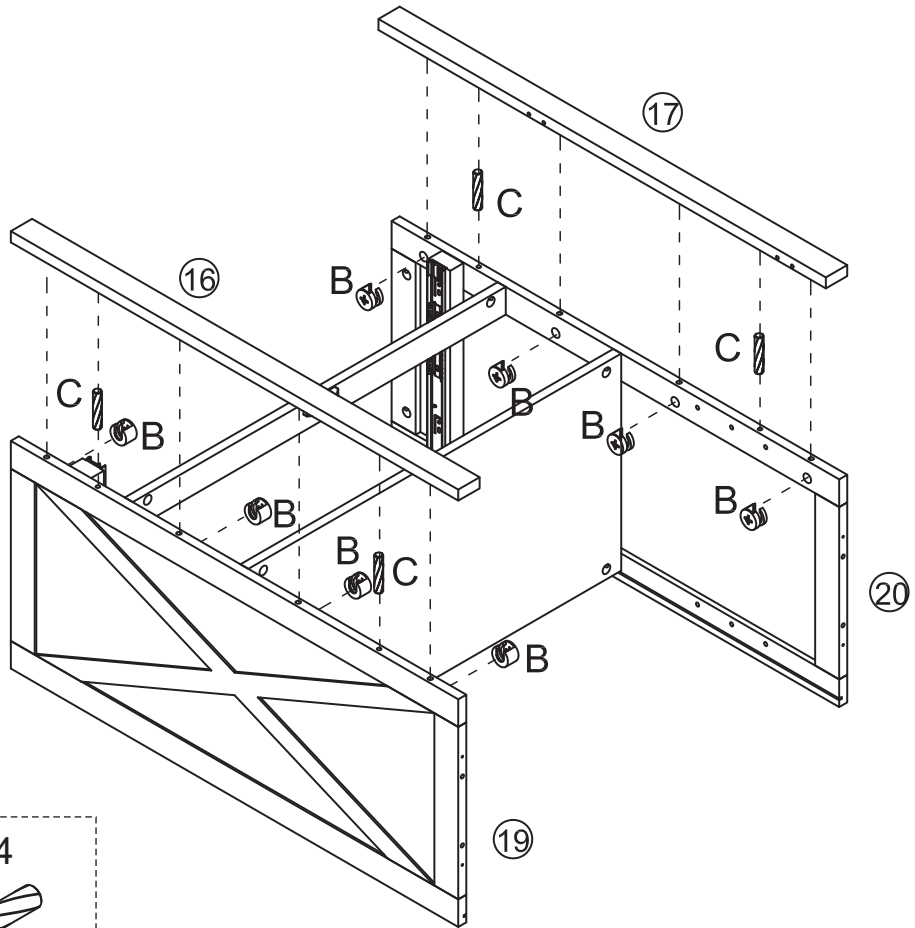
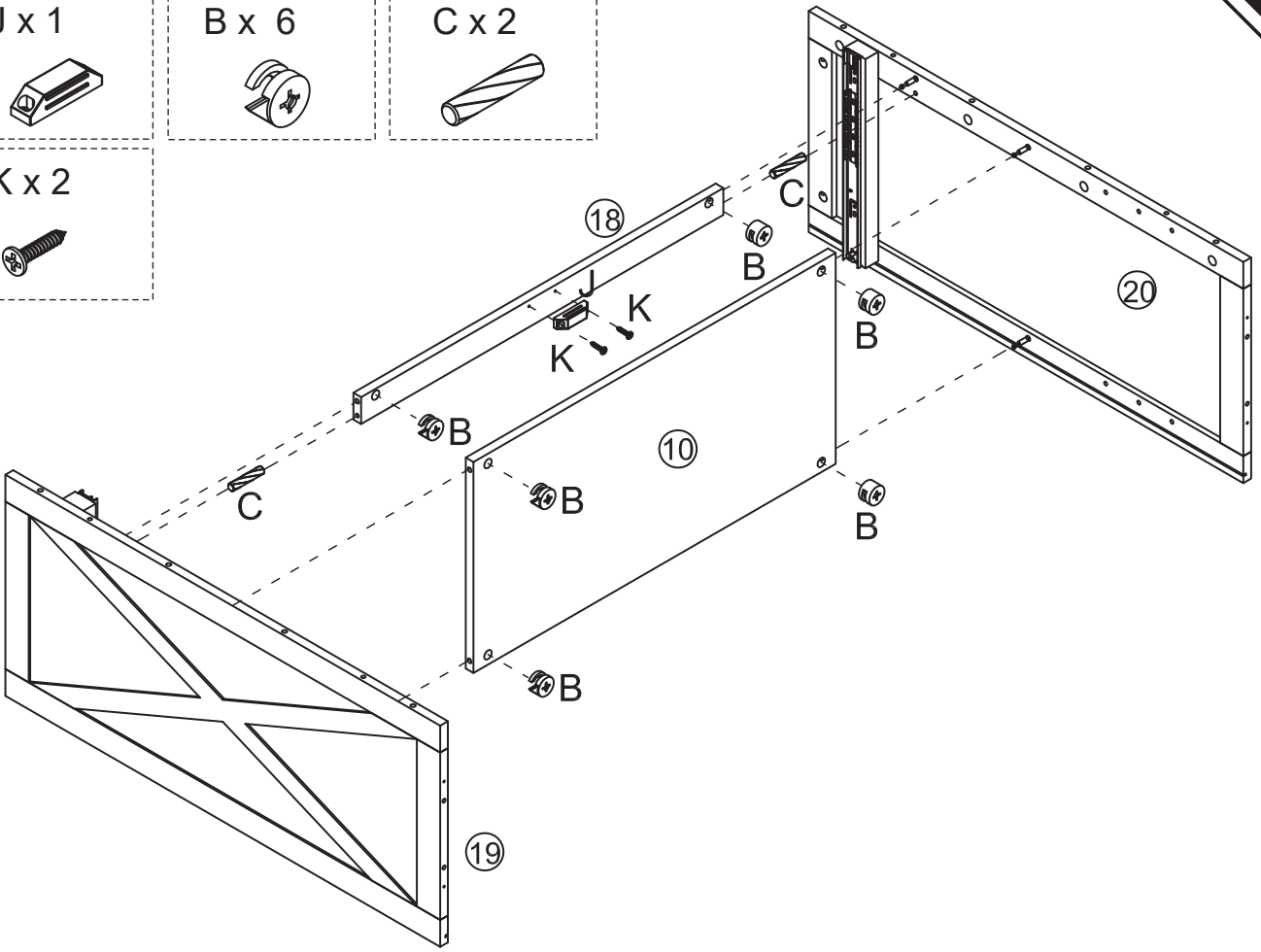

B x 8



C x 4

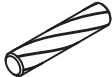

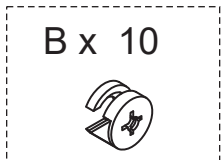
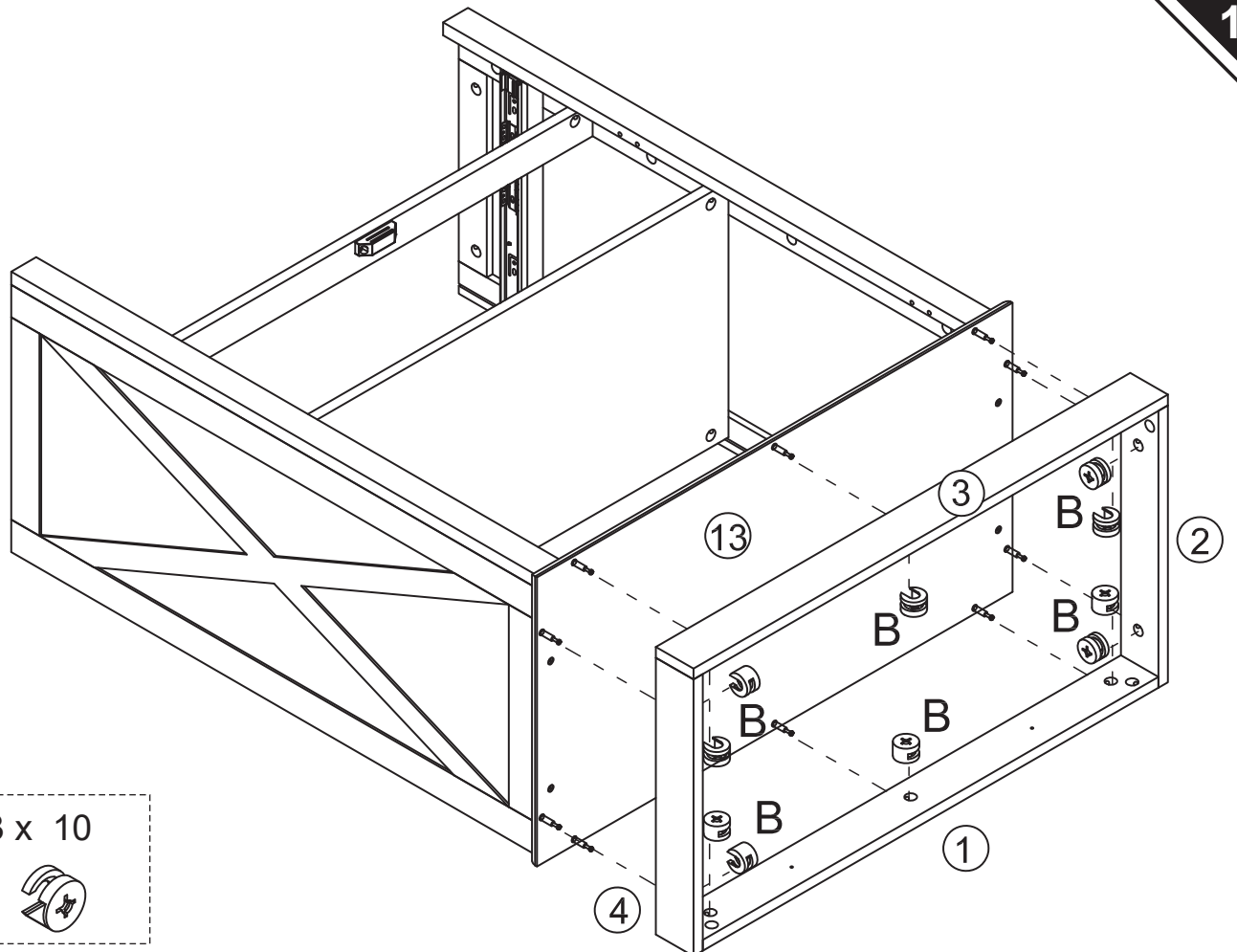
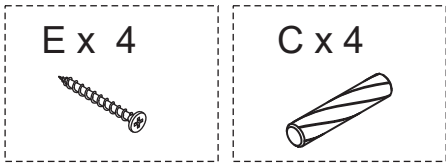
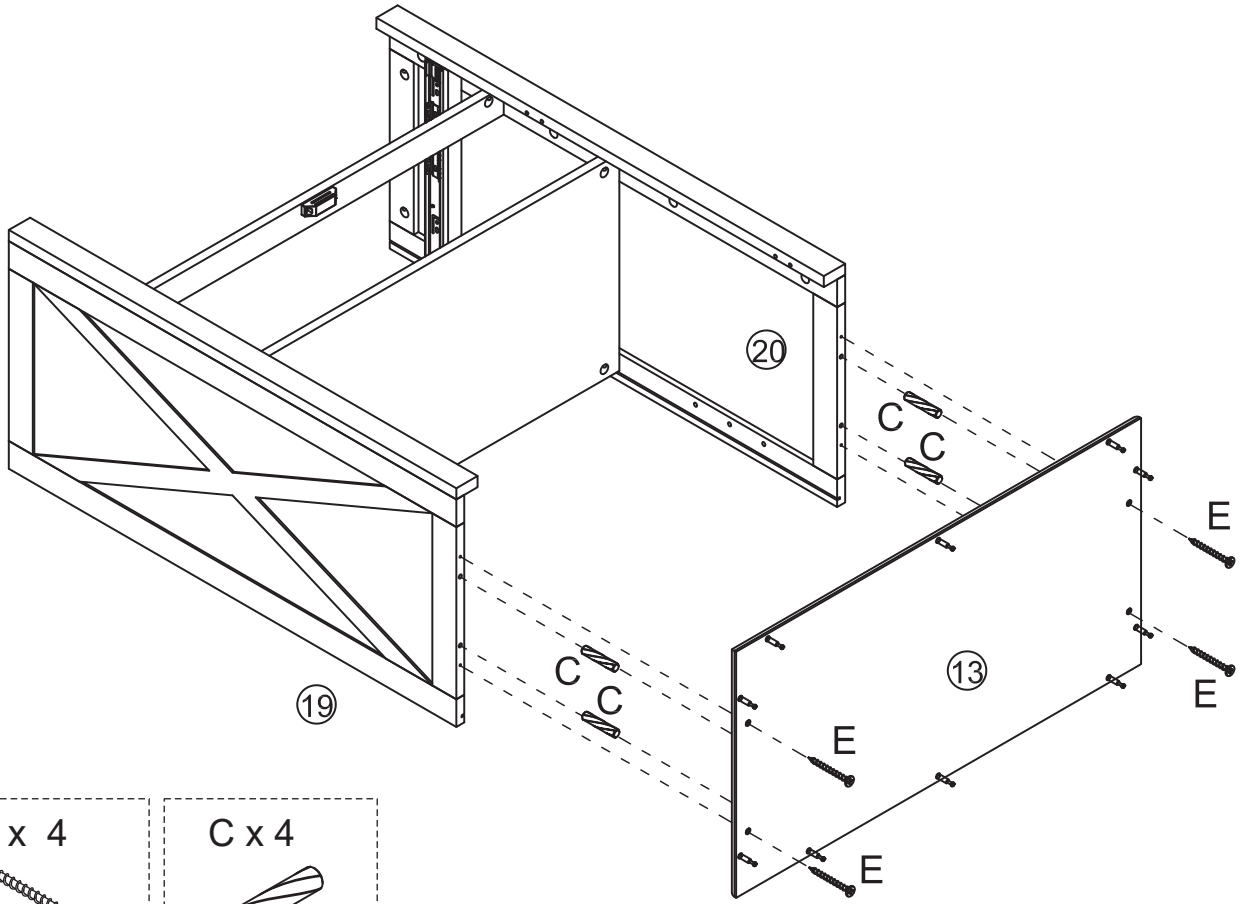

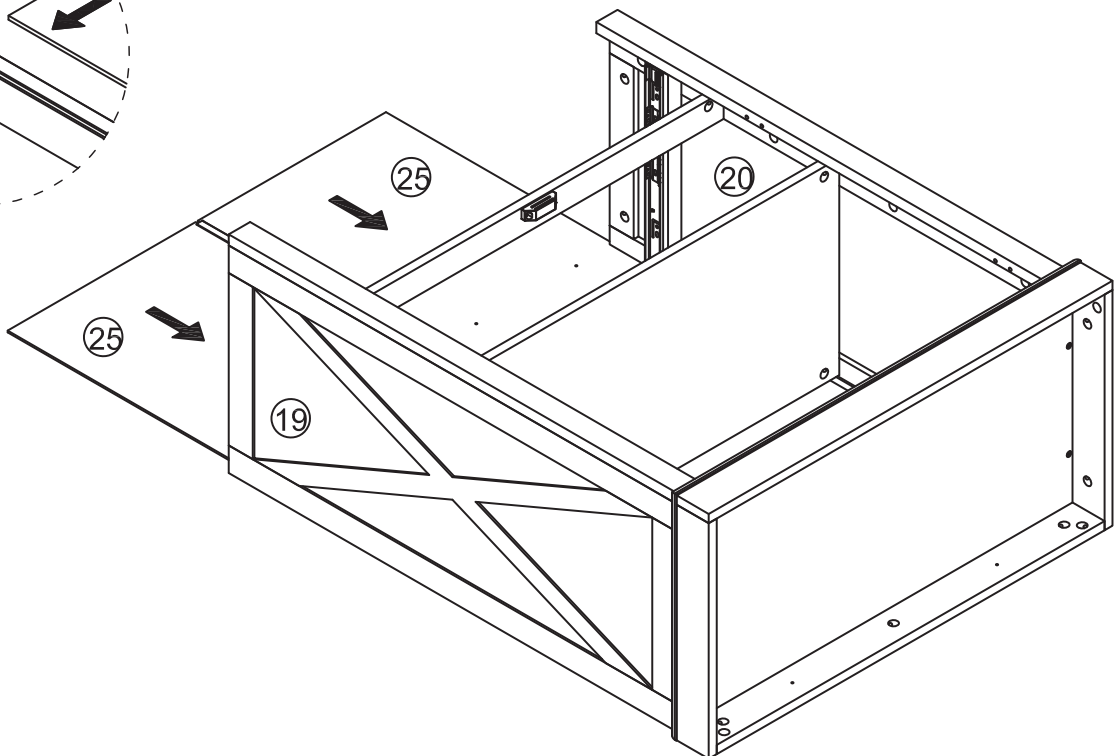
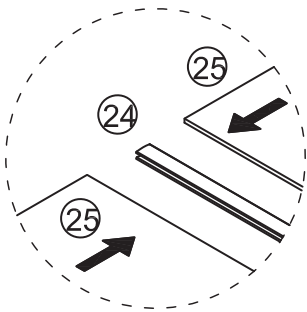
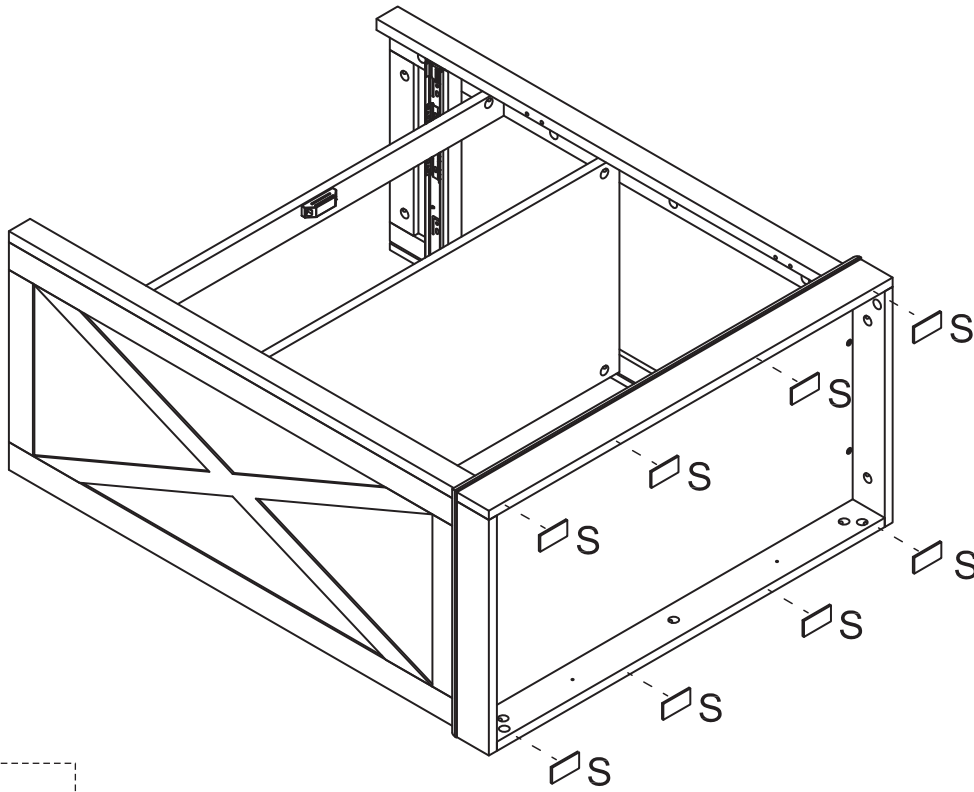



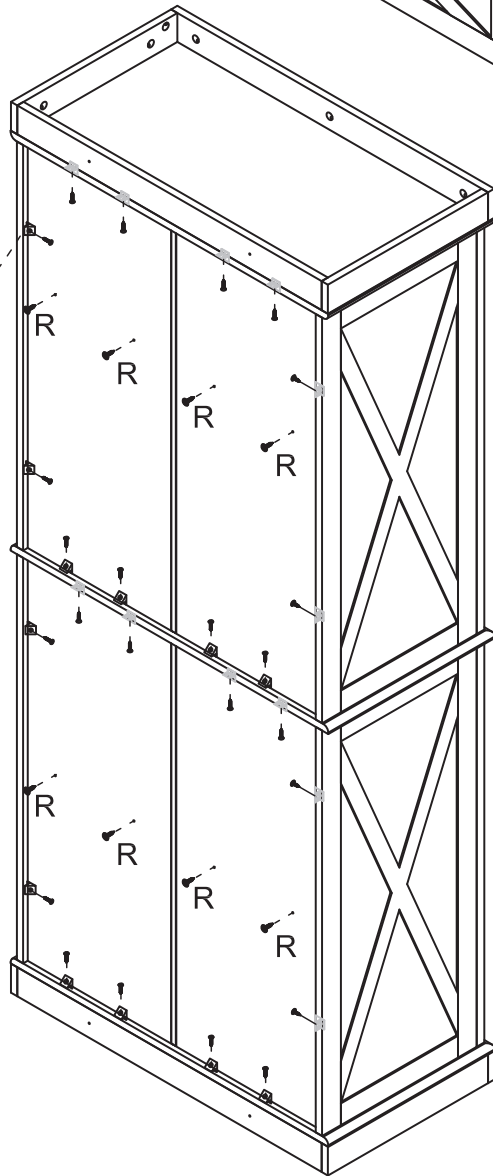
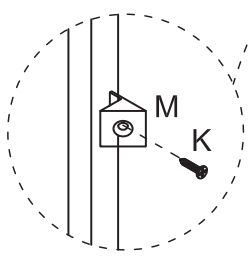
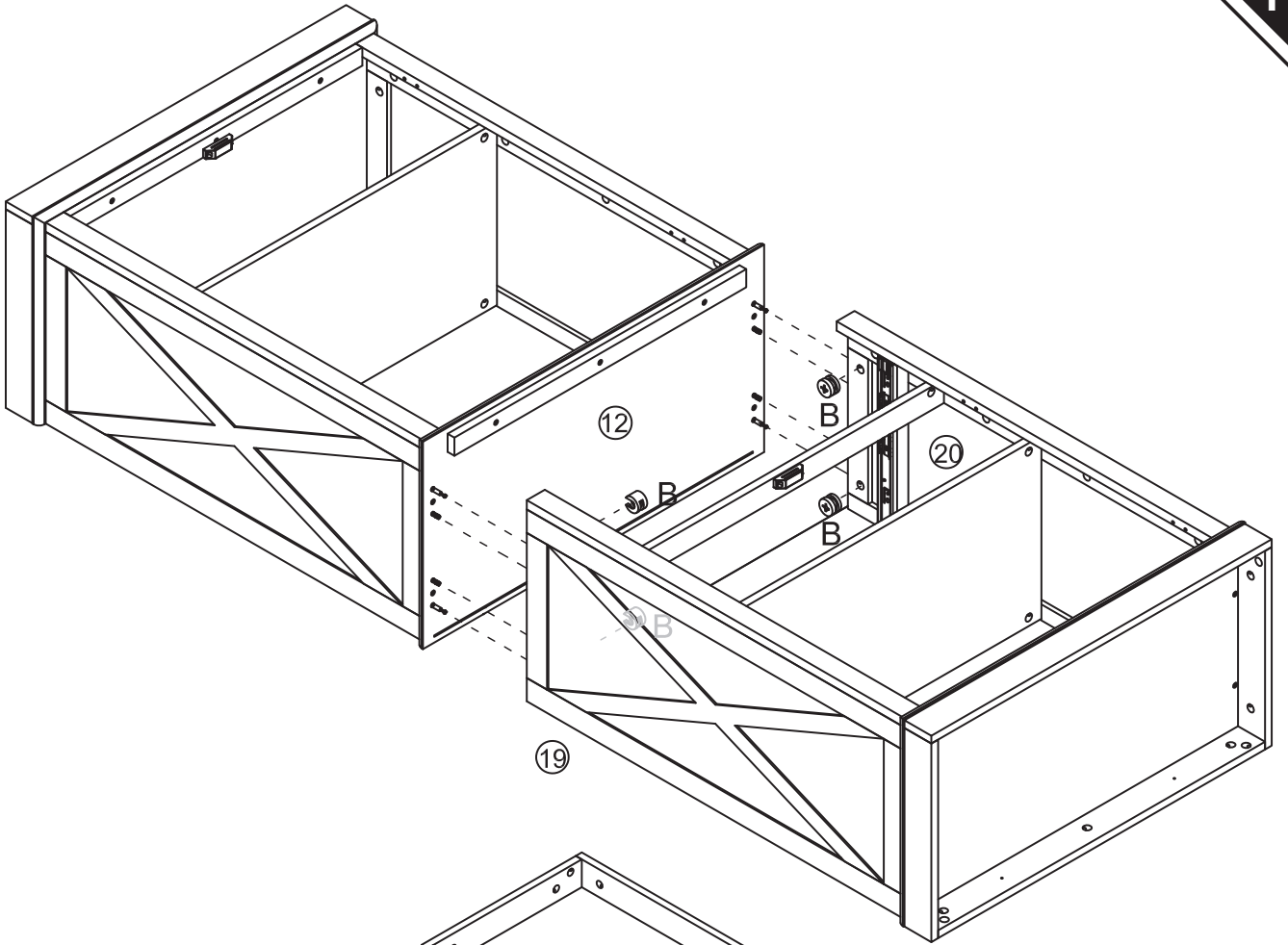





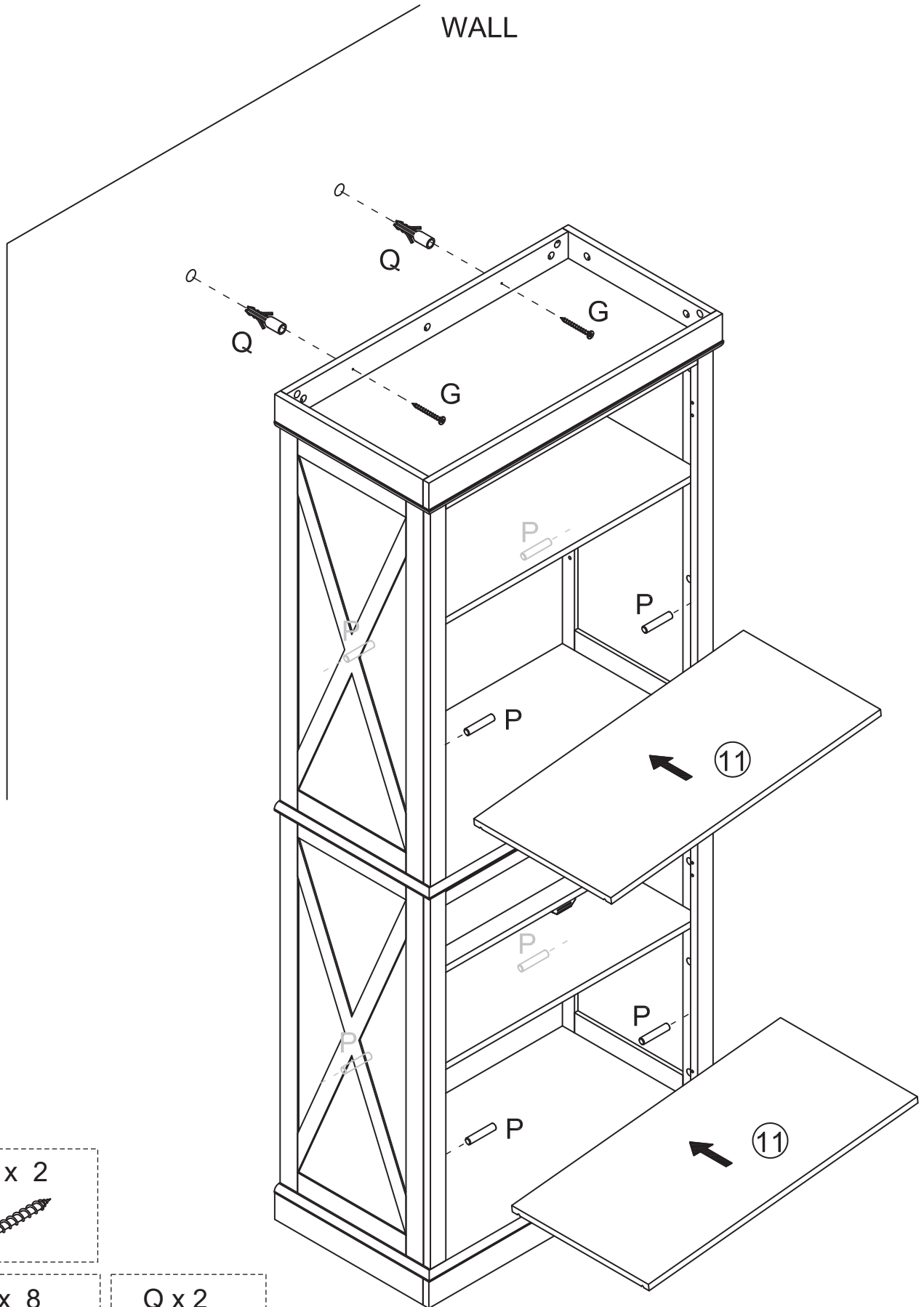

M x 24 	K x 24 
B x 4 	R x 8 

WALL



G x 2



P x 8







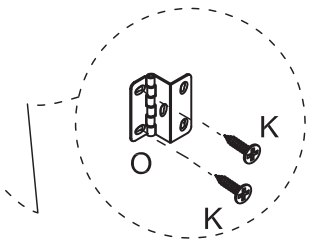
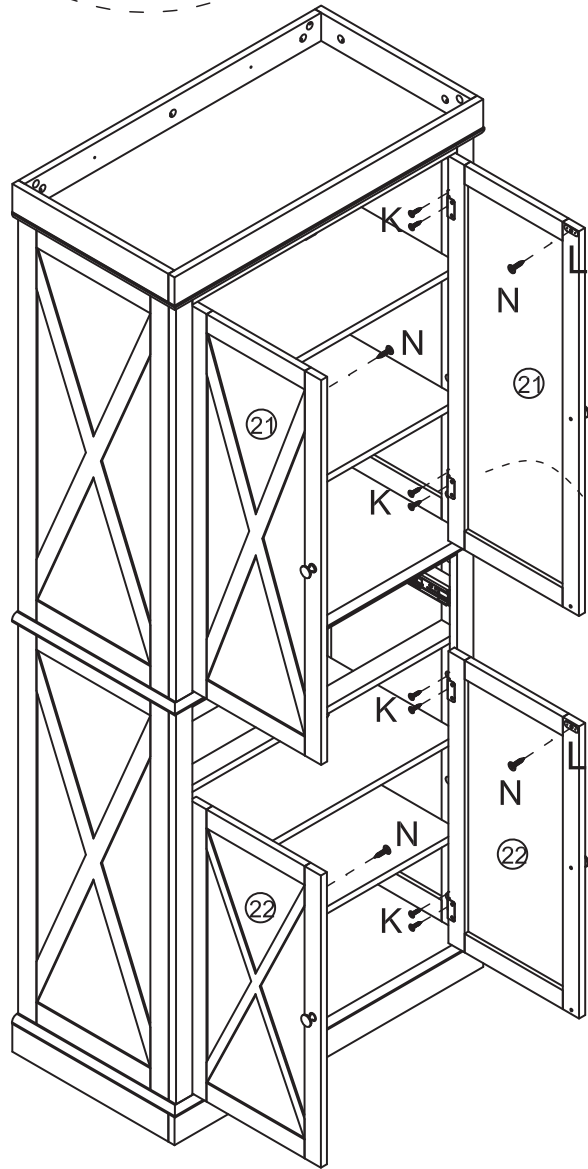
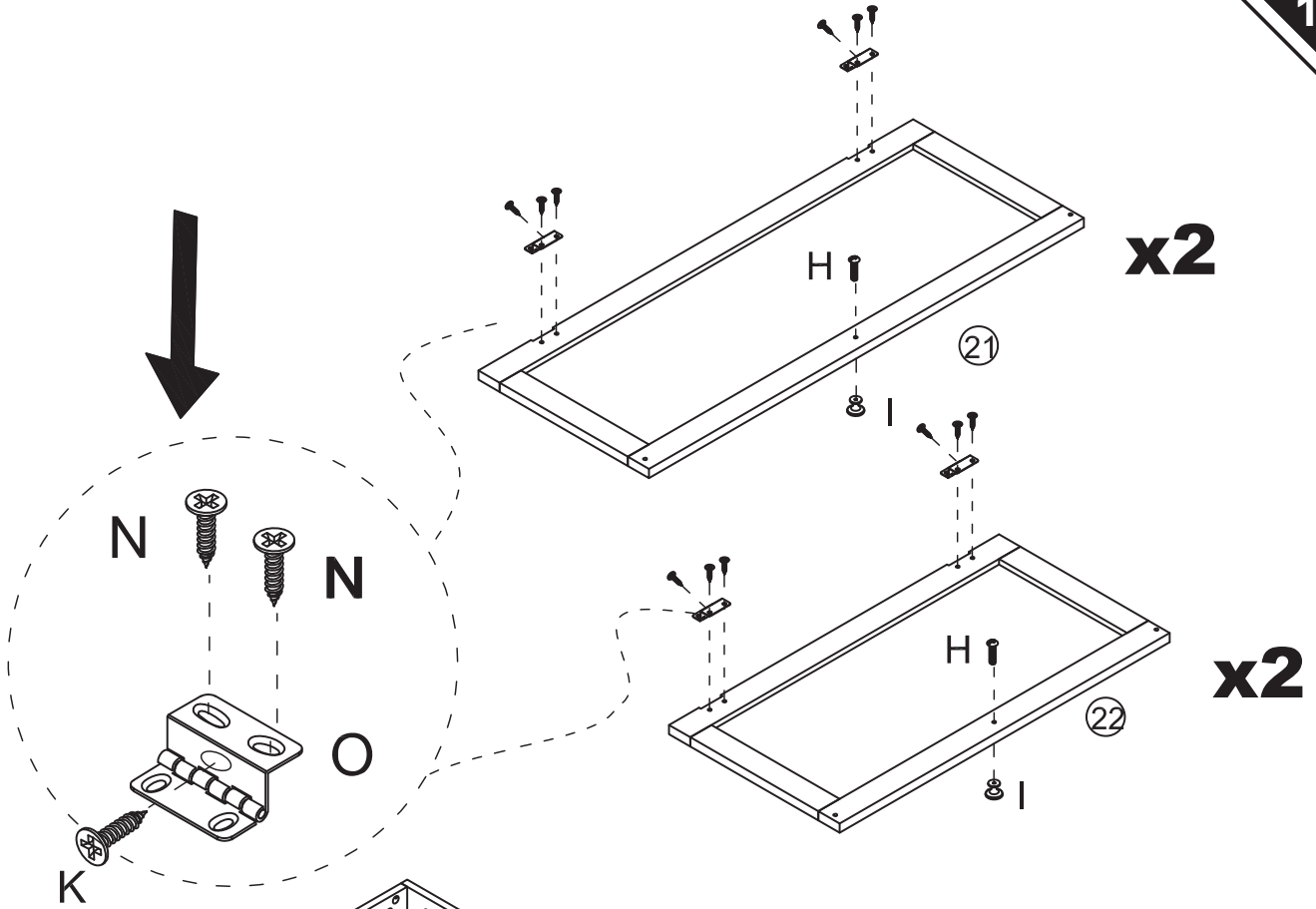

Q x 2

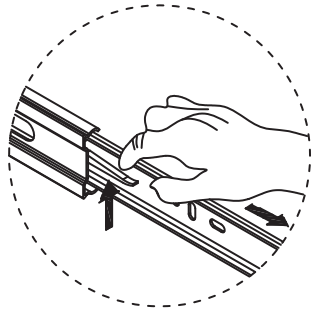
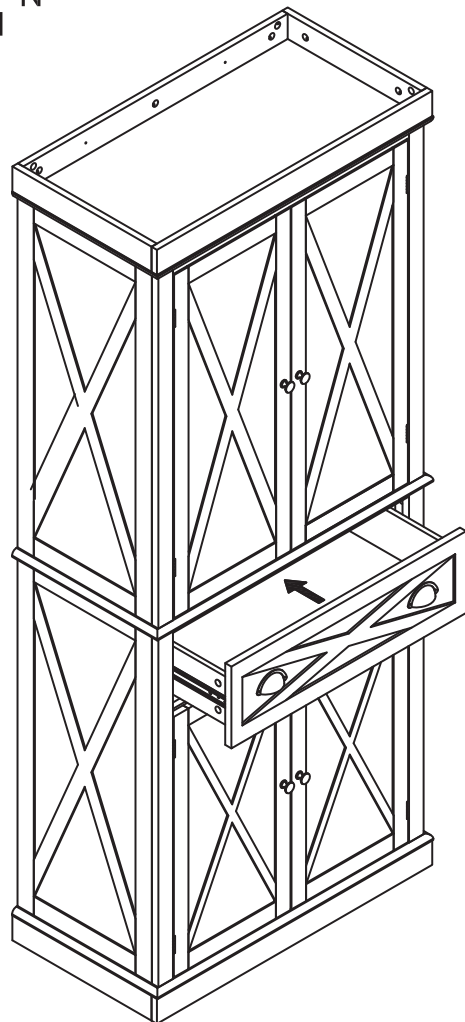
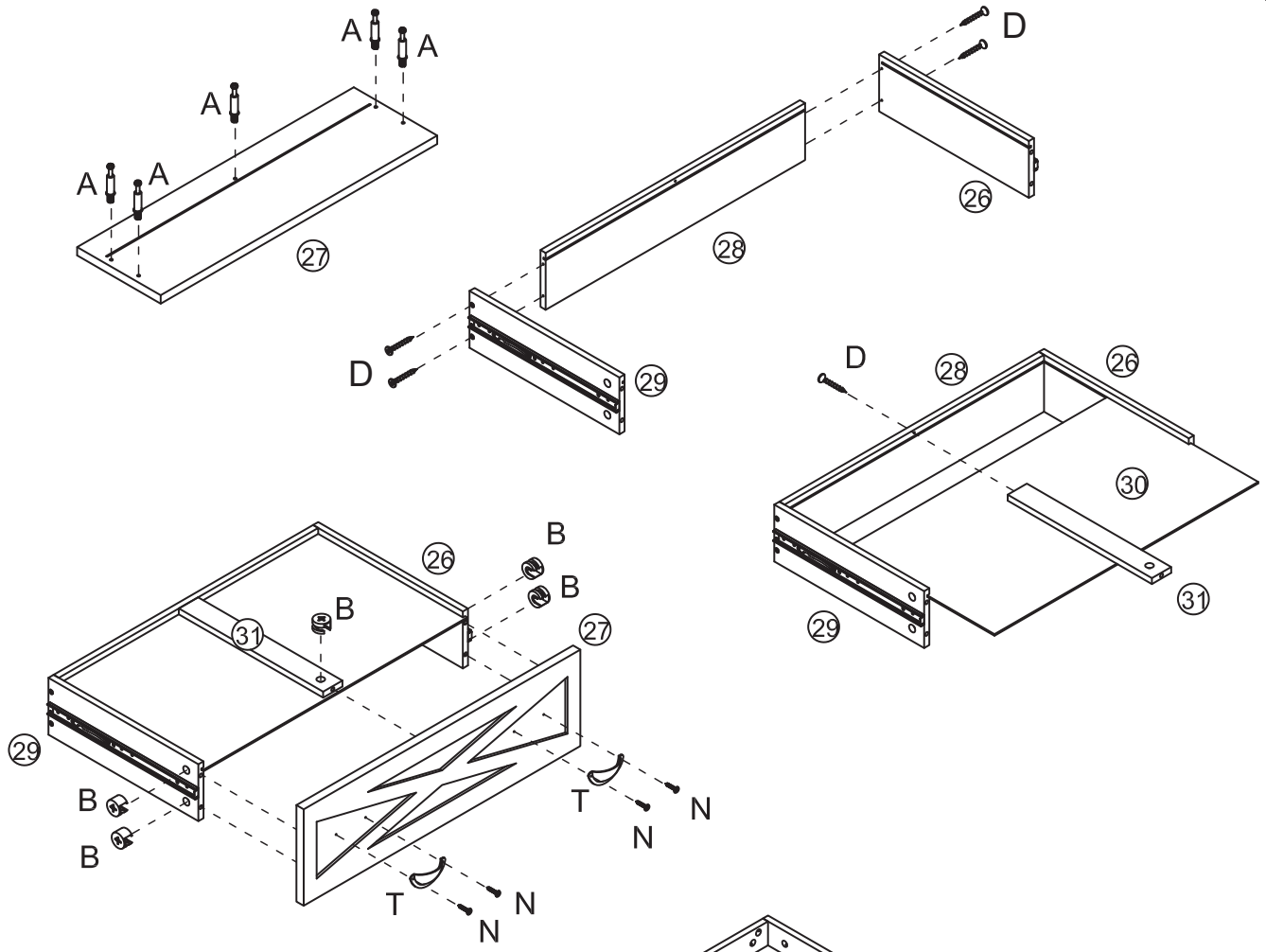



H x 4	I x 4
L x 4	N x 20
O x 8	K x 24



- B x 5 
- D x 5 
- N x 4 
- T x 2 
- A x 5 

**EN** Loosen or Tighten the screws to adjust the door as your request:

**FR** Desserrez ou serrez les vis pour ajuster la porte au besoin :

**ES** Afloje o apriete los tornillos para ajustar la puerta según sus requisitos:

**PT** Solte ou aperte os parafusos para ajustar a porta conforme sua necessidade:

**DE** Lösen Sie die Schrauben oder ziehen Sie sie fest, um die Tür nach Ihren Wünschen einzustellen:

**IT** Allentare o stringere le vite per regolare la porta come desidera:

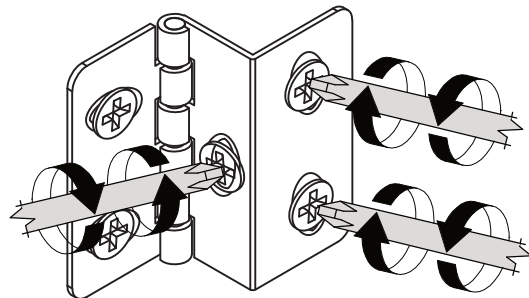
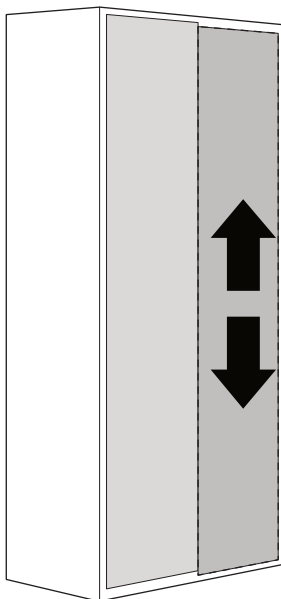
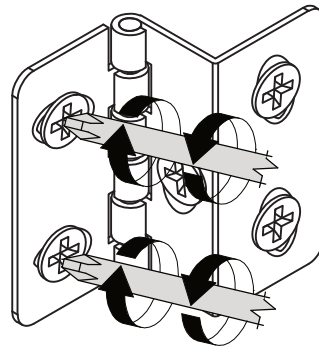
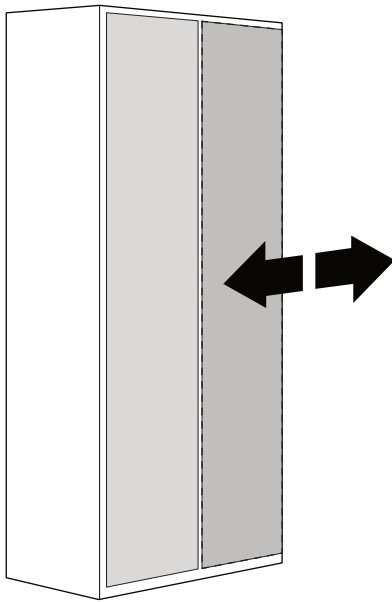

**US**

Imported by Aosom LLC  
 27150 SW Kinsman Rd Wilsonville, OR 97070 USA  
 MADE IN CHINA

**CA**

Imported by Aosom Canada Inc.  
 7270 Woodbine Avenue, Unit 307, Markham, Ontario Canada  
 L3R 4B9  
 MADE IN CHINA

Importé par Aosom Canada Inc.  
 7270 Woodbine Avenue, unité 307, Markham, Ontario Canada  
 L3R 4B9  
 Fabriqué en Chine

**UK**

IMPORTER ADDRESS:  
 MH STAR UK LTD  
 Unit 27, Perivale Park,  
 Horsenden lane South  
 Perivale, UB6 7RH  
 MADE IN CHINA

**FR**

ADRESSE D'IMPORTATION:  
 MH FRANCE  
 2 Rue Maurice Hartmann  
 92130 Issy Les Moulineaux  
 France  
 FABRIQUÉ EN CHINE



**FR**

**Pensez à donner ou recycler.**

Association ou Magasin ou Déchèterie

<https://quefairedemesdechets.fr>

**ES**

IMPORTADOR:  
 SPANISH AOSOM, S.L.  
 C/ROC GROS, Nº15.08550, ELS HOSTALET DE BALENYÀ, SPAIN.  
 B66295775  
 WWW.AOSOM.ES  
 ATENCIONCLIENTE@AOSOM.ES  
 TEL: 931294512  
 HECHO EN CHINA

**PT**

SPANISH AOSOM, S.L  
 C.ROC GROS N.15, 08550. ELS HOSTALET DE BALENYÀ  
 TEL: 931294512 (SEG-SEX DAS 7:30H ÀS 16:30H)  
 INFO@AOSOM.PT  
 WWW.AOSOM.PT

**DE**

ADRESSE DES IMPORTEURE:  
 MH Handel GmbH  
 Wendenstraße 309  
 D-20537 Hamburg  
 Germany  
 IN CHINA HERGESTELLT

**IT**

IMPORTATO DA:  
 AOSOM Italy srl  
 Centro Direzionale Milanofiori  
 Strada 1 Palazzo F1  
 20057 Assago (MI)  
 P.I.: 08567220960  
 FATTO IN CINA