

ZONEKIZ

IN220800336V01_UK_FR_DE_ES_IT

312-095V00

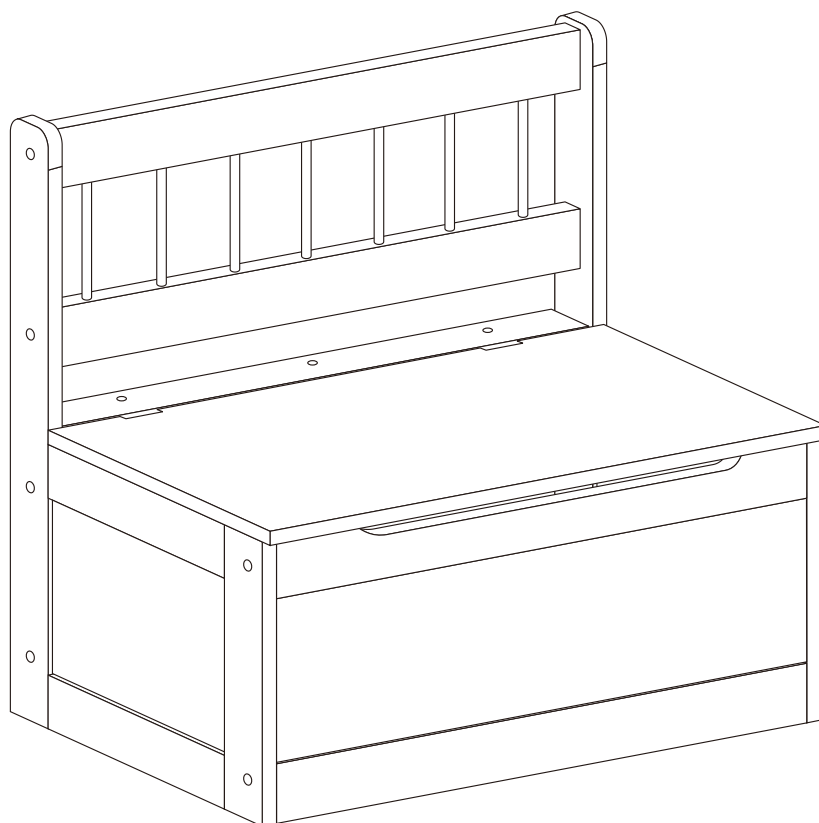

EN: **WARNING:** Suitable for children of 18-48 months; Max weight: 50 kg.

DE: **WARNUNG:** Geeignet für Kinder im Alter von 18-48 Monate; Max. Gewicht: 50 kg.

FR: **ATTENTION:** Convient aux enfants de 18 à 48 mois; Poids maximum : 50 kg.

ES: **ADVERTENCIA:** Adecuado para los niños de 18 a 48 meses; Peso máximo: 50 kg.

IT: **ATTENZIONE:** Adatto a bambini di 18-48 mesi; Peso massimo: 50 kg.

EN_IMPORTANT, RETAIN FOR FUTURE REFERENCE: READ CAREFULLY.

FR_IMPORTANT: A LIRE ATTENTIVEMENT ET À CONSERVER POUR CONSULTATION ULTÉRIEURE.

ES_IMPORTANTE, LEA Y GUARDE PARA FUTURAS REFERENCIAS.

DE_WICHTIG! SORGFÄLTIG LESEN UND FÜR SPÄTER NACHSCHLAGEN AUFBEWAHREN.

IT_IMPORTANTE! CONSERVARE IL PRESENTE MANUALE PER FUTURO RIFERIMENTO E LEGGERLO ATTENTAMENTE.

EN

Dear customer,

Thank you for purchasing this product. So that your appliance serves you well, please read all the instructions in this user's manual. If you have any questions, please contact our customer care center.

FR

Cher client,

Nous vous remercions d'avoir acheté ce produit. Afin que vous puissiez profiter pleinement de votre appareil, veuillez lire toutes les instructions de ce manuel d'utilisation. Si vous avez la moindre question, veuillez contacter notre centre d'assistance à la clientèle.

DE

Sehr geehrter Kunde,

Vielen Dank, dass Sie dieses Produkt erworben haben. Damit Ihr Gerät Ihnen gute Dienste leistet, lesen Sie bitte alle Hinweise in diesem Benutzerhandbuch. Wenn Sie Fragen haben, wenden Sie sich bitte an unser Kundendienstzentrum.

ES

Queridos clientes,

Gracias por comprar este producto. Para que su electrodoméstico le sirva mejor, lea todas las instrucciones de este manual del usuario. Si tiene alguna pregunta, comuníquese con nuestro Centro de Atención al Cliente.

PT

Caros clientes,

Obrigado por adquirir este produto. Para que o seu aparelho o sirva melhor, leia todas as instruções deste manual do utilizador. Se tiver alguma dúvida, por favor contacte o nosso Centro de Atendimento ao Cliente.

IT

Caro Cliente,

Grazie per aver acquistato questo prodotto. Per servirti meglio con questo apparecchio ti prego di leggere tutte le istruzioni in presente manuale utente. In caso di dubbio, si prega di contattare il nostro centro assistenza clienti.

EN_Our contact details are below:



FR_Nos coordonnées sont les suivantes:

DE_Unsere Kontaktdaten stehen unten:

ES_Nuestros datos de contacto son los siguientes:

PT_Os nossos dados de contacto são os seguintes:

IT_I nostri dettagli di contatto sono di seguito:

Country	 Phone	 Email
UK	0044-800-240-4004	enquiries@mhstar.co.uk
DE	0049-0(40)-88307530	service@aosom.de
FR	0033-1-84166106	aosom@mhfrance.fr
ES&PT	0034-931294512	atencioncliente@aosom.es
IT	0039-0249471447	clienti@aosom.it

WARNING:

1. Only allowed for adults to install, keep children away.
2. To be used under the direct supervision of an adult.
3. Place it on a flat and clean floor, Check all the parts are well connected before use.

MAINTENANCE & CARE

- A. Keep all instructions and parts relating to this product for future reference.
- B. Please wipe down with a dry or damp cloth.

AVERTISSEMENT :

1. Installation par des adultes uniquement, tenir les enfants à l'écart.
2. À utiliser sous la surveillance directe d'un adulte.
3. Posez-le sur un sol plat et propre. Vérifiez que toutes les pièces sont bien connectées avant toute utilisation.

ENTRETIEN ET MAINTENANCE

- A. Conservez toutes les instructions et les pièces relatives à ce produit pour pouvoir vous y référer ultérieurement.
- B. Veuillez essuyer avec un chiffon sec ou humide.



FR

**Pensez à
donner ou recycler.**



Association

ou



Magasin

ou



Déchèterie

<https://quefairedemesdechets.fr>

WARNUNG:

1. Die Montage darf nur von Erwachsenen vorgenommen werden, halten Sie Kinder fern.
2. Es ist unter der direkten Aufsicht eines Erwachsenen zu verwenden.
3. Stellen Sie es auf einen flachen und sauberen Boden. Prüfen Sie, ob alle Teile vor der Verwendung gut verbunden sind.

WARTUNG & PFLEGE

- A. Bewahren Sie alle Anweisungen und Teile, die sich auf dieses Produkt beziehen, zur späteren Verwendung auf.
- B. Bitte wischen Sie es mit einem trockenen oder feuchten Tuch ab.

ADVERTENCIA:

1. La instalación sólo se puede realizar por los adultos, mantenga a los niños alejados al instalar el producto.
2. El producto debe ser utilizado bajo la supervisión directa de un adulto.
3. Colóquelo sobre un piso plano y limpio. Verifique si todas las piezas estén conectadas adecuadamente antes de utilizarlo.

MANTENIMIENTO Y CUIDADO

- A. Guarde todas las instrucciones y piezas relativas juntas con este producto para las referencias futuras.
- B. Límpielo con un paño seco o humedecido.









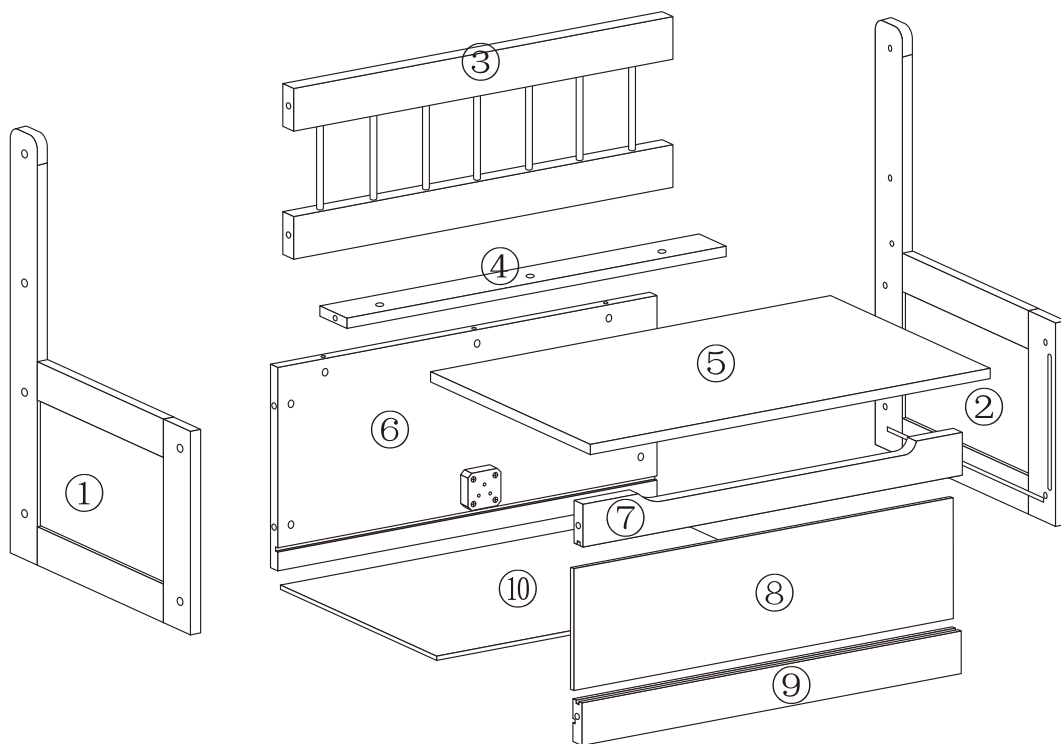

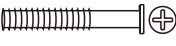
AVVERTENZE:

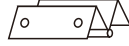
1. Consentito solo agli adulti di installare, tenere lontani i bambini.
2. Da utilizzare sotto la diretta supervisione di un adulto.
3. Posizionarlo su una superficie piana e pulita, controllare che tutte le parti siano connesse correttamente prima dell'uso.



MANUTENZIONE & CURA

- A. Conservare tutte le istruzioni e le parti relative a questo prodotto per riferimenti futuri.
- B. Si prega di pulire passando un panno asciutto o inumidito.

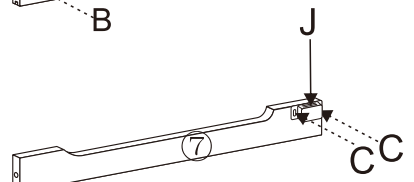
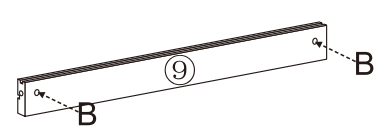
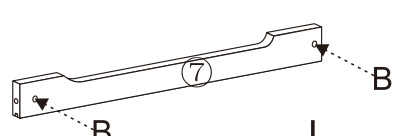
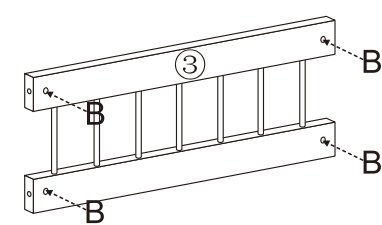
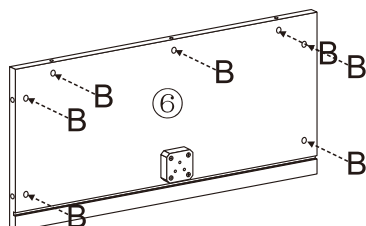

<p>A x15 +1(spare)</p>  <p>6X45mm</p>	<p>B x15 +1(spare)</p> 	<p>C x12 +1(spare)</p>  <p>3X10mm</p>	<p>D x 2</p> 	<p>E x 2</p> 	<p>F x 5 +1(spare)</p>  <p>4X15mm</p>
<p>G x 1</p> 	<p>H x 1</p> 	<p>I x 1</p> 	<p>J x 1</p> 	<p>K x 1</p> 	





 <p>B=15pcs</p>	 <p>C=2pcs</p>	 <p>J=1pc</p>
---	--	---

02

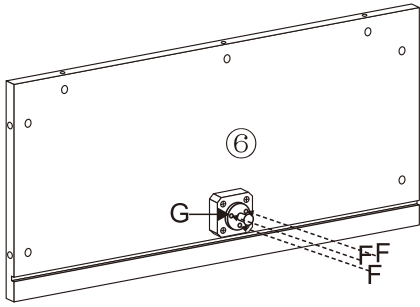
 F=3pcs	 G=1pc
--	---

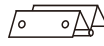

03

 C=10pcs	 D=2pcs
 E=2pcs	 K=1pc

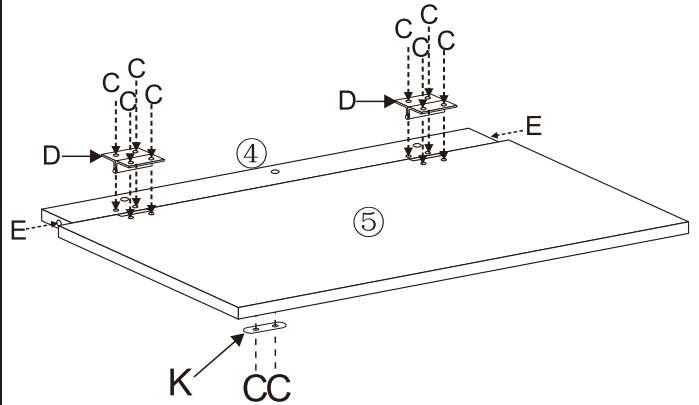

04

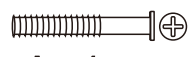
 A=4pcs
--

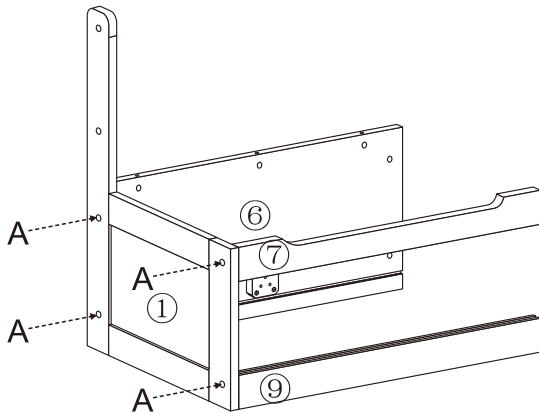

05

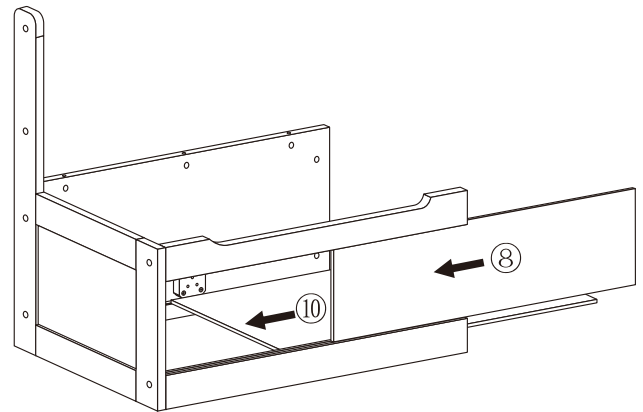

06

 A=3pcs
--

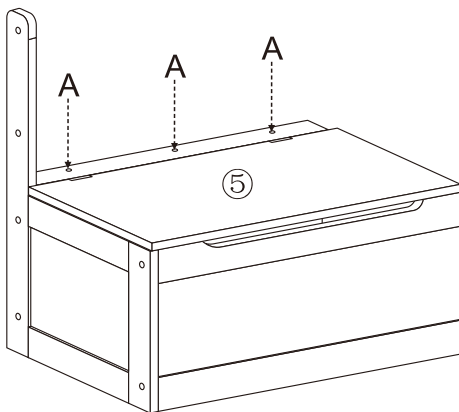

07

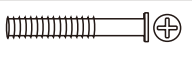
 A=4pcs

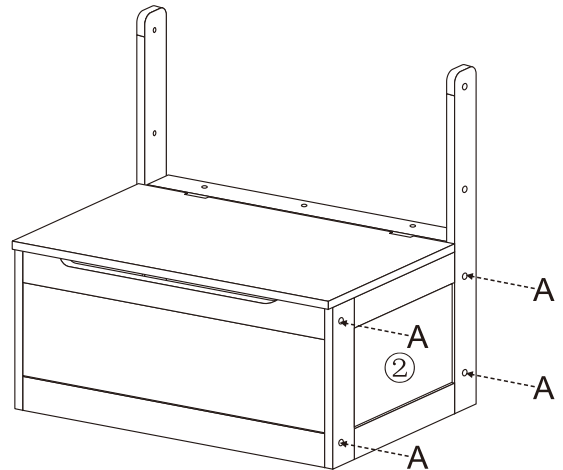

08

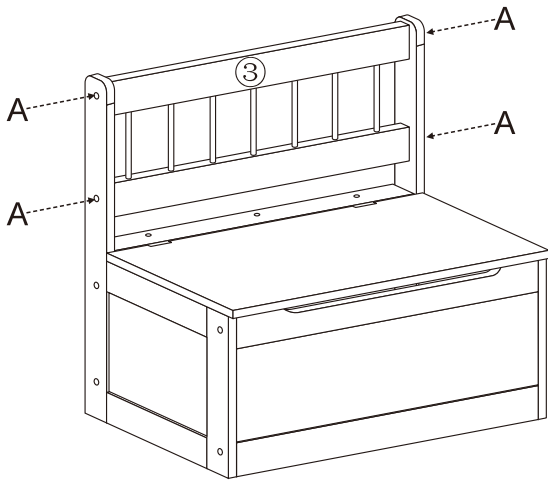
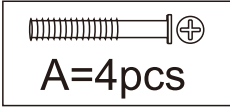

09

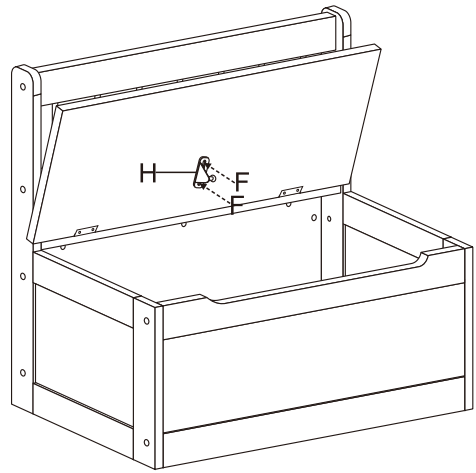
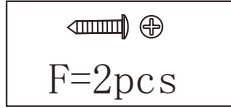

10

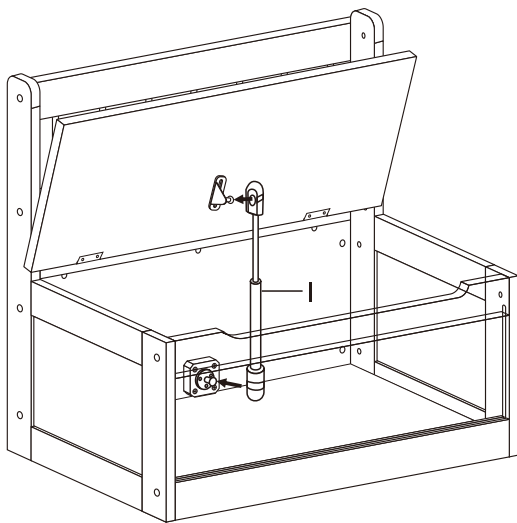
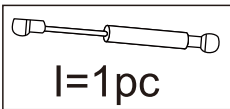

11

