

SPORTNOW

IN220800648V02_UK_ES

A61-035V00_A61-037V01_A61-037V00

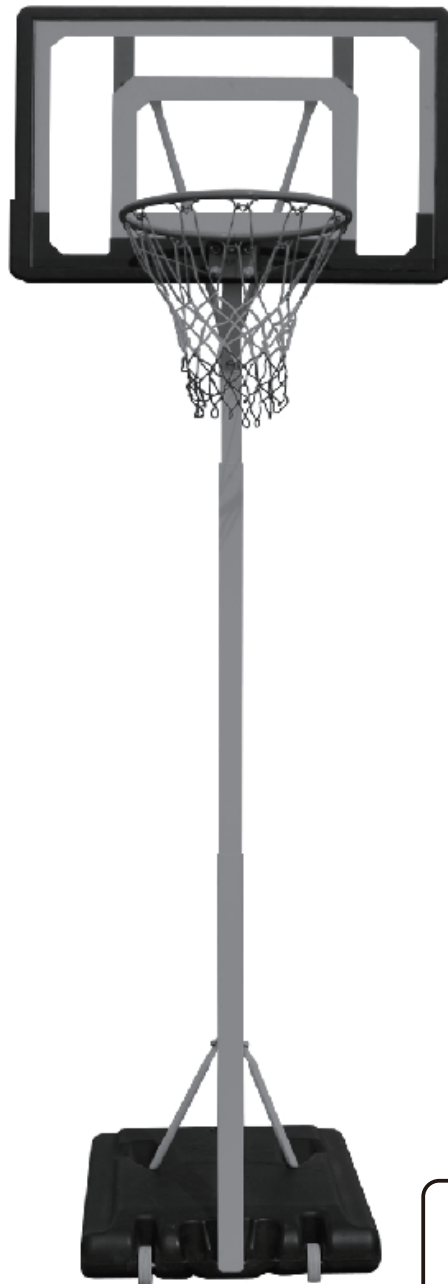

EN

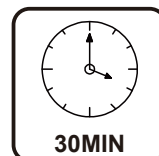
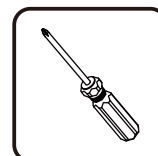

IMPORTANT, RETAIN FOR FUTURE REFERENCE: READ CAREFULLY

ASSEMBLY INSTRUCTION

SAFETY INSTRUCTIONS

To ensure safety, do not assemble this product without following all instructions. Check all packaging, ensuring all parts are present and not damaged. A high risk of serious injury can occur if this appliance is not installed, maintained and used properly.

* The equipment should be moved by at least three adults, who are capable of handling its weight. Children should not move this appliance .

* Check the base regularly (if possible) for leakages. Slow leaks can cause the product to tip over.

* Stand in front of the product and pull the pole forward, so it is balanced on its wheels.

* Move the appliance to the desired location and carefully set the base down.

Warning

1. Do not hang on the rim or any parts of the product, including backboard, support braces and net.
2. Do not use if parts are damaged. If there are any issues with parts, please contact customer service.
3. Do not leave the system in an upright position without filling the base with water, as it could tip over and cause injury.
4. Do not fill the base with water in freezing temperatures, as the water could freeze and cause damage. Instead, use sand to fill the base.
5. Keep top pole and lifter pole covered with the cap at all times.
6. When playing, do not wear jewellery - it could get tangled or damaged.
7. When adjusting height or moving the product, keep hands away from moving parts.
8. Do not allow children to move or adjust the product.

Product moving

1. Adjust the product to its lowest level before moving
2. Avoid friction with the ground while moving.
3. Rise the product slowly.

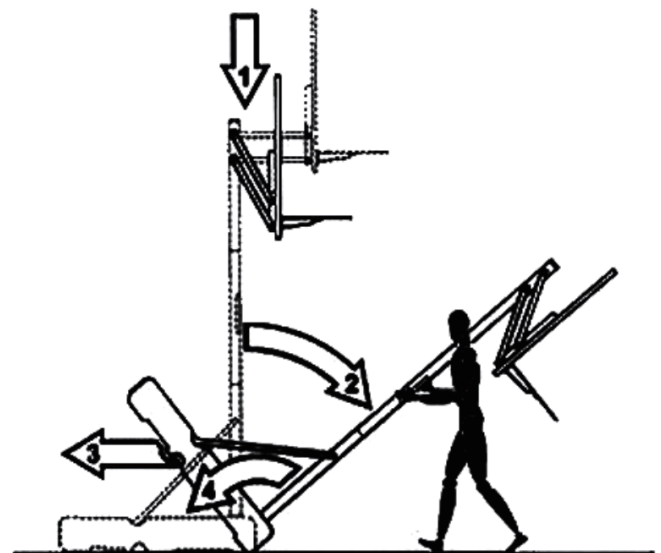

NO.	QTY	NAME	REMARK
A	1	M8*40MM Plastic head knob	knob fix Top pole(L)&Middle pole(K)
B	2	M8*35MM	Connect Rim(N),Backboard(O)&Top pole(L)
C	2	M8*16MM	Fix Backboard brace(G)&Backboard(O)
D	2	M8*65MM	Fix Top pole(L)&Middle pole(K) Fix Top pole(L)& Backboard brace(G)
E	3	M8*65MM	Connect Bottom pole(J)&Base(P)
F	2	M8*20MM	Connect Base(P)&Support brace(H)
G	2	Backboard brace	Connect Backboard(O)&Top pole(L)
H	2	Support brace	Connect Bottom pole(J)&Base(P)
I	2	Wheel	
J	1	Bottom Pole	50*50MM Square Tube
K	1	Middle Pole	45*45MM Square Tube
L	1	Top Pole	40*40MM Square Tube
M	1	Wheel Shaft	
N	1	Rim	
O	1	Backboard	
P	1	Base	

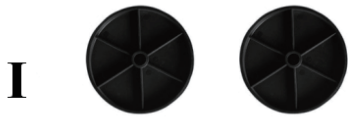
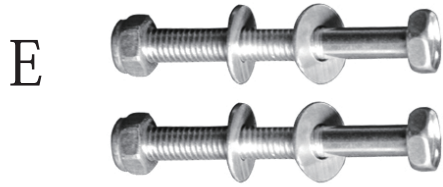

Installation details

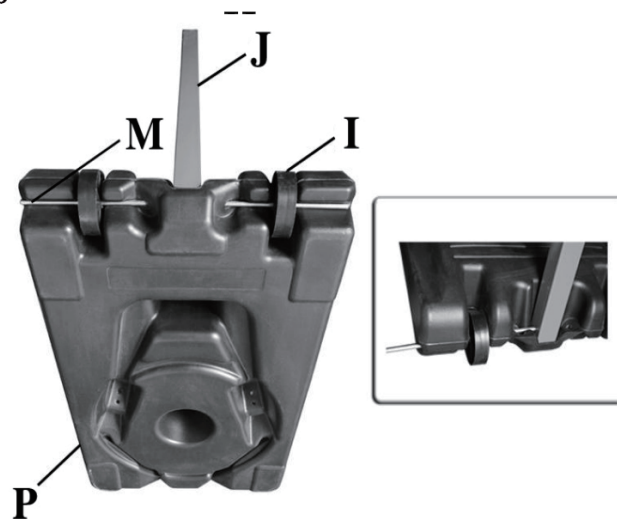

Step 1: Assembly wheelshaft, wheel and bottom tube

Insert the wheel shaft(M) into the front holes of the base(P), also insert the left wheel(I), bottom tube(J) and right wheel(I) in turn as shown.

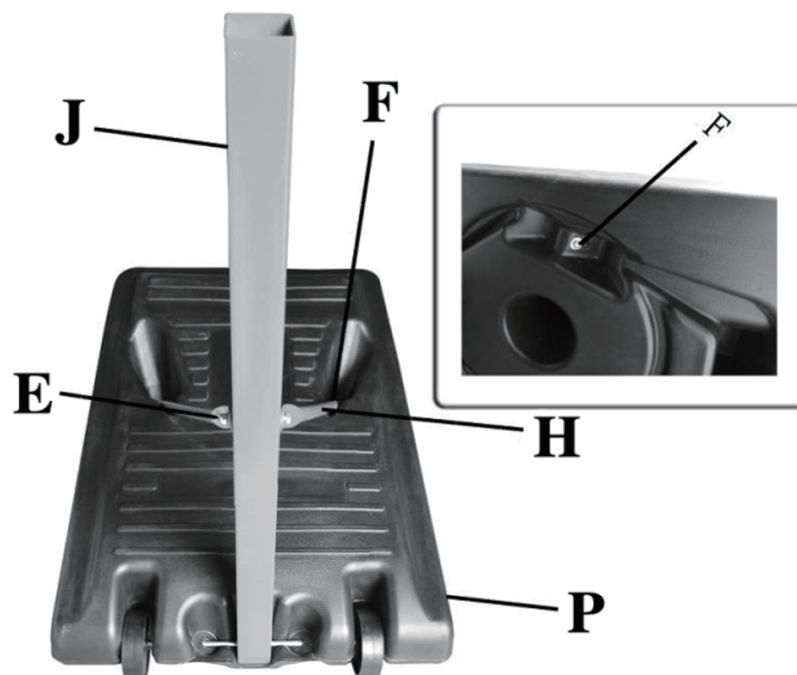

Step 2: Assembly Base

Fix one end of the 2 support braces (H) on the base by screws (F), then fix another end of the 2 support braces(H) on the bottom tube (J) by screw (E) as shown. Finally filling the base with water or sand to keep steady.

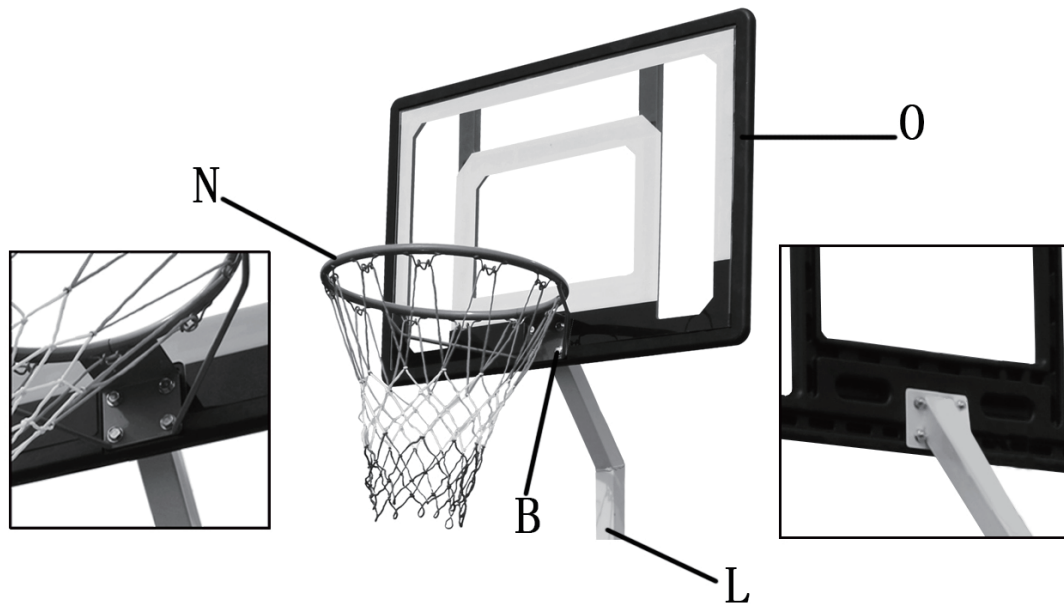

Step 3: Assembly of the rim, backboard and top tube

Assemble the rim (N), backboard (O) and top tube (L) by screws (B) as shown.

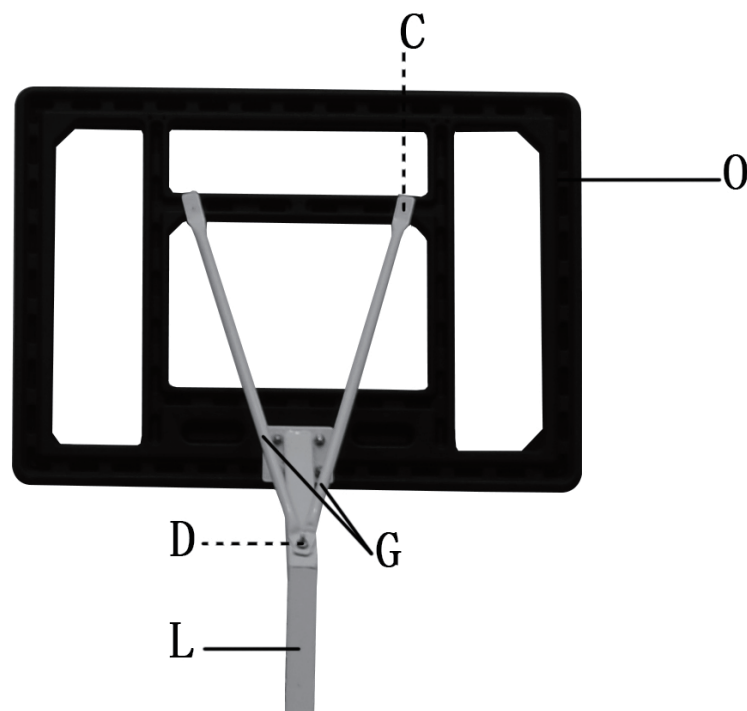

Step 4: Assembly of backboard braces

Fix one end of the backboard braces (G) on top tube (L) by screw (D), then fix another end of the backboard braces (G) on backboard by screw (C) as shown.

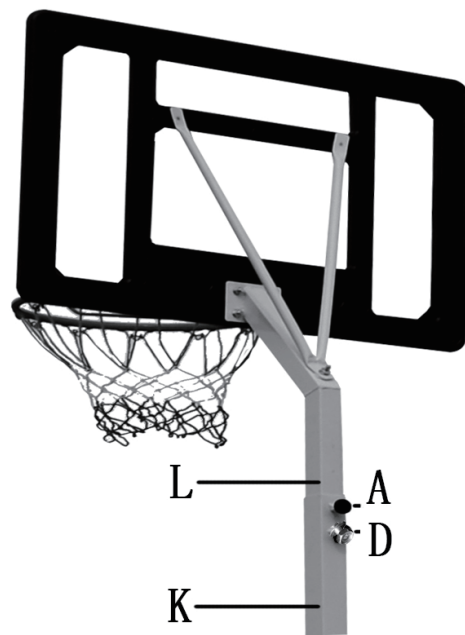

Step 5: Assembly of top tube and middle tube

Insert the top tube (L) into the middle tube (K) .The height is adjustable as per requirement .Lock the tubes by the knob (A), (D) as shown.

Notice :the adjustment range is from 2.1m--2.6m

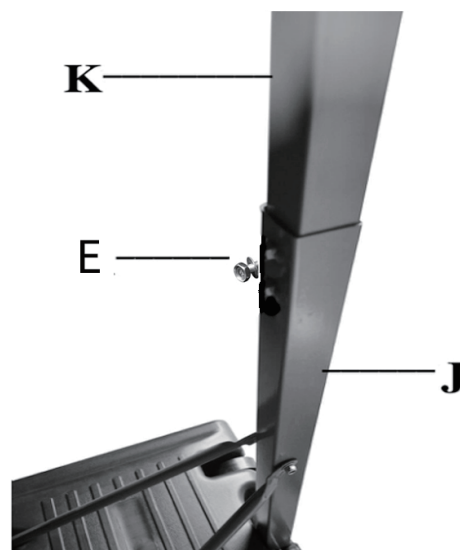

Step 6: Assembly of middle tube and bottom tube

Insert the middle tube (K) into the bottom tube (J) ,use the plastic head knob (E) to lock them as shown.

Install net on Rim(N) as shown

1.

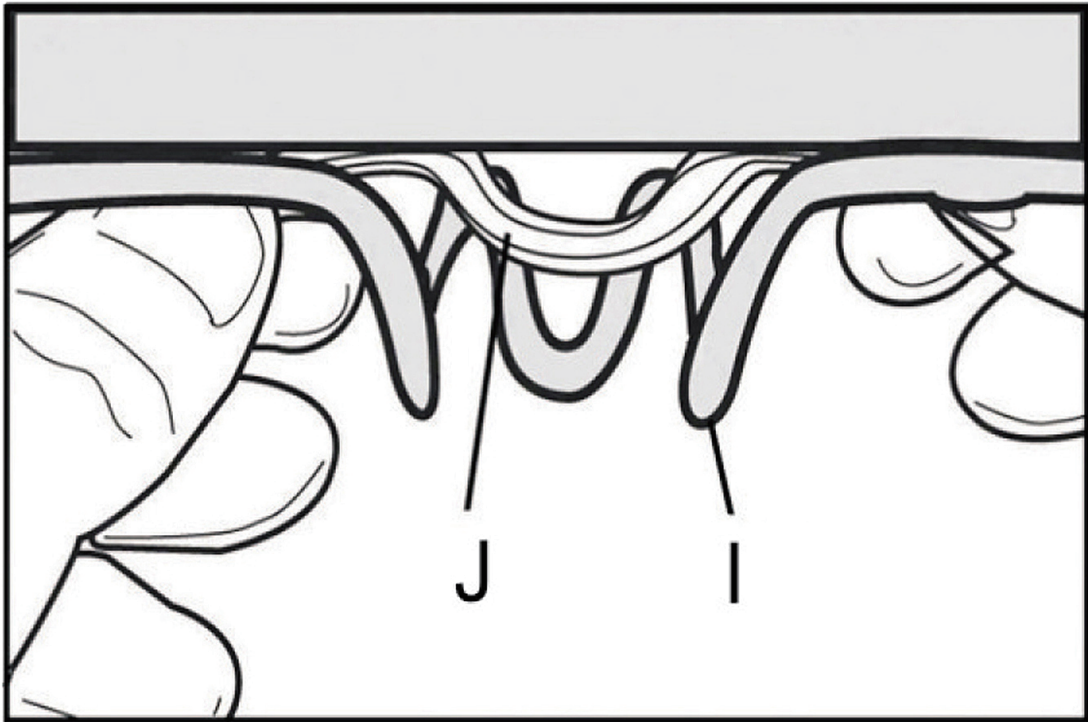

2.

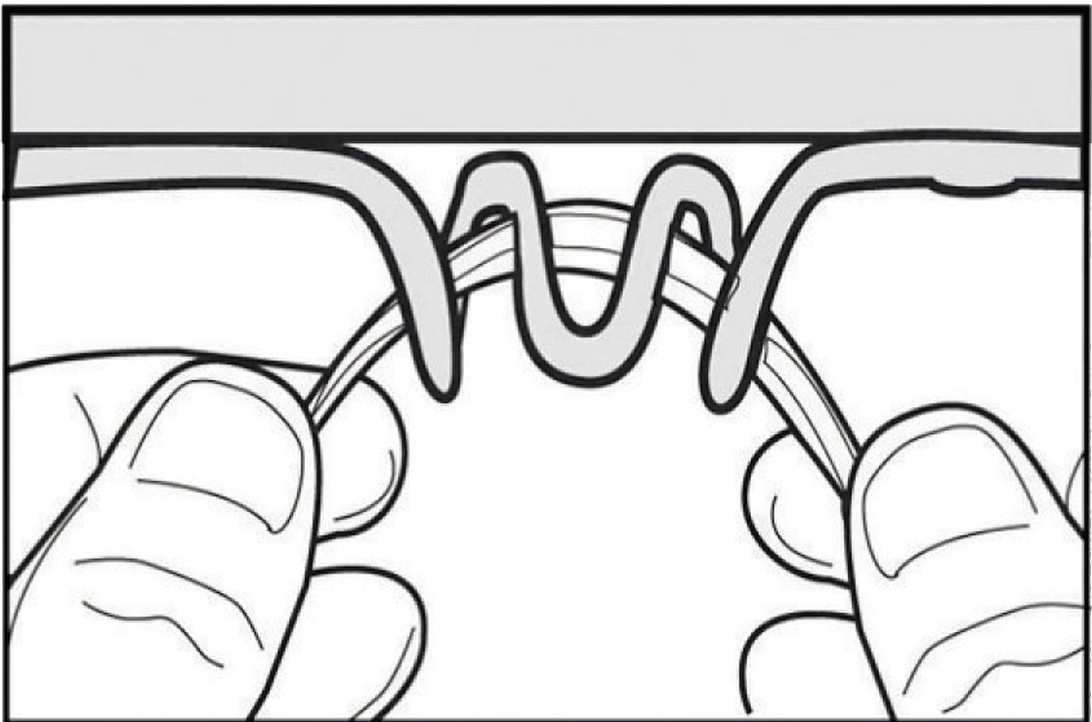

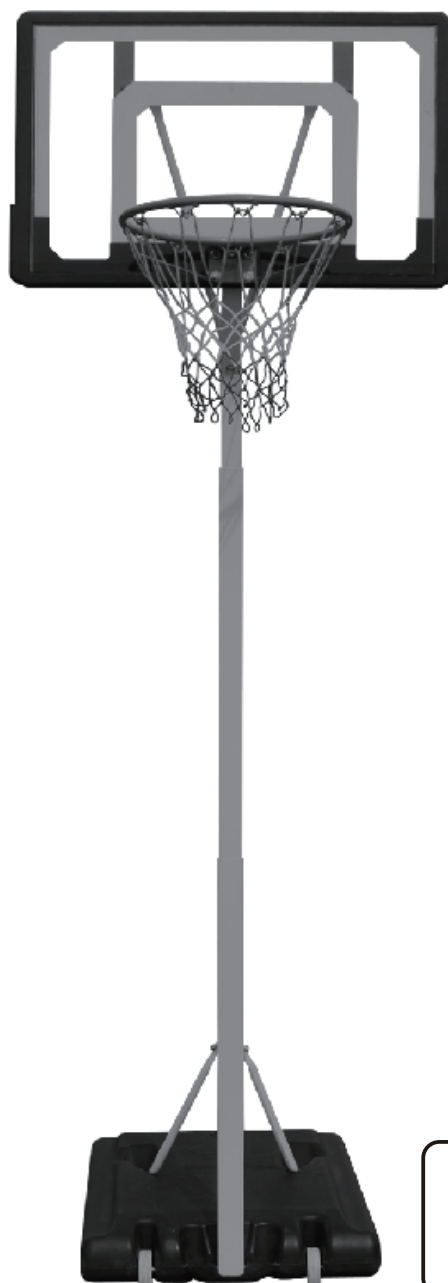

ES

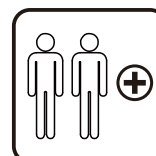
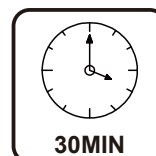
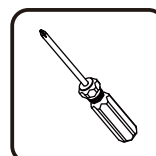

IMPORTANTE - CONSERVE ESTA INFORMACIÓN PARA SU CONSULTA POSTERIOR: LEER DETALLADAMENTE

MANUAL DE INSTRUCCIONES

INSTRUCCIONES DE SEGURIDAD

Para garantizar su seguridad, no monte este producto sin seguir las instrucciones. Controle el embalaje, asegurándose de que estén todas las piezas y no dañadas. Si este aparato no se instala, mantiene y utiliza correctamente se corre un alto riesgo de lesiones.

* El equipo debe ser movido por al menos tres adultos, que sean capaces de manejar su peso. Los niños no deben mover este aparato.

* Revise la base con regularidad (si es posible) para ver si hay fugas. Las fugas lentas pueden hacer que el producto se vuelque.

* Párese frente al producto y jale el poste hacia adelante, de manera que quede equilibrado sobre sus ruedas.

* Mueva el aparato a la ubicación deseada y coloque la base con cuidado.

Advertencia

1. No lo cuelgue del borde ni de ninguna parte del producto, incluidos el tablero, las abrazaderas de soporte y la red.
2. No lo use si las piezas están dañadas. Si hay algún problema con las piezas, póngase en contacto con el servicio de atención al cliente.
3. No deje el sistema en posición vertical sin llenar la base con agua, ya que podría volcarse y causar lesiones.
4. No llene la base con agua a temperaturas bajo cero, ya que el agua podría congelarse y causar daños. En su lugar, use arena para llenar la base.
5. Mantenga el poste superior y el poste del levantador cubiertos con la tapa en todo momento.
6. Cuando juegues, no uses joyas, ya que podrían enredarse o dañarse.
7. Al ajustar la altura o mover el producto, mantenga las manos lejos de las piezas móviles.
8. No permita que los niños muevan o ajusten el producto.

Producto en movimiento

1. Ajuste el producto a su nivel más bajo antes de moverlo.
2. Evitar el roce con el suelo mientras lo mueve.
3. Levante el producto lentamente.

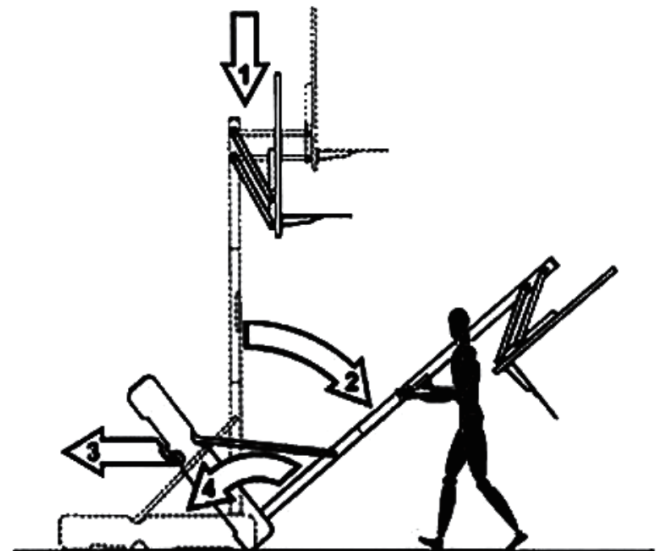

NO.	CANT.	NOMBRE	INDICACIONES
A	1	M8*40MM Perilla de cabeza de plástico	Perilla de fijación Poste superior (L) y poste central (K)
B	2	M8*35MM	Conecte el borde (N), el tablero trasero (O) y el poste superior (L)
C	2	M8*16MM	Arreglar la abrazadera del tablero (G) y el tablero (O)
D	2	M8*65MM	Fijar el poste superior (L) y el poste medio (K) Fije el poste superior (L) y la abrazadera del tablero (G)
E	3	M8*65MM	Conecte el poste inferior (J) y la base (P)
F	2	M8*20MM	Base de conexión (P) y abrazadera de soporte (H)
G	2	Refuerzo de tablero	Conecte el tablero (O) y el poste superior (L)
H	2	Abrazadera de apoyo	Conecte el poste inferior (J) y la base (P)
I	2	Rueda	
J	1	Poste inferior	50*50MM Tubo
K	1	Poste medio	45*45MM Tubo
L	1	Poste superior	40*40MM Tubo
M	1	Eje de rueda	
N	1	Borde	
O	1	Respaldo	
P	1	Base	

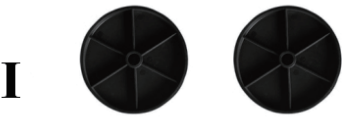
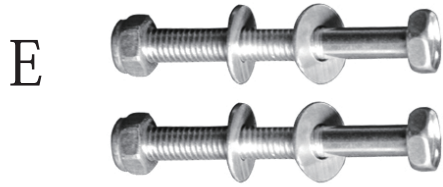

Detalles de instalación

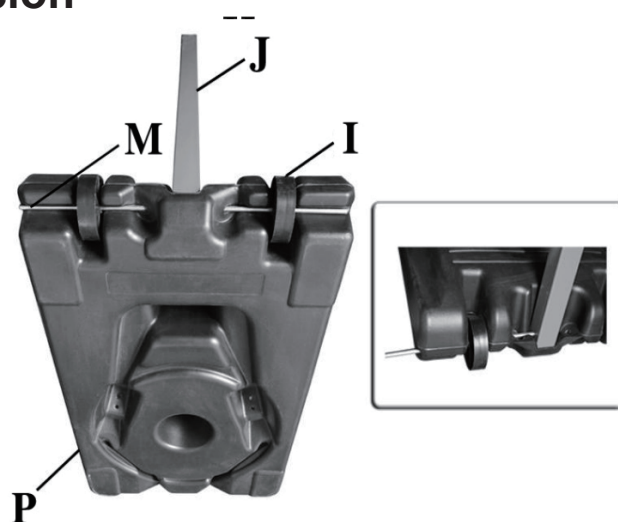

Paso 1: Montaje del eje de rueda, rueda y tubo inferior

Inserte el eje de la rueda (M) en los orificios delanteros de la base (P), luego inserte la rueda izquierda (I), tubo inferior (J) y rueda derecha (I) como se muestra.

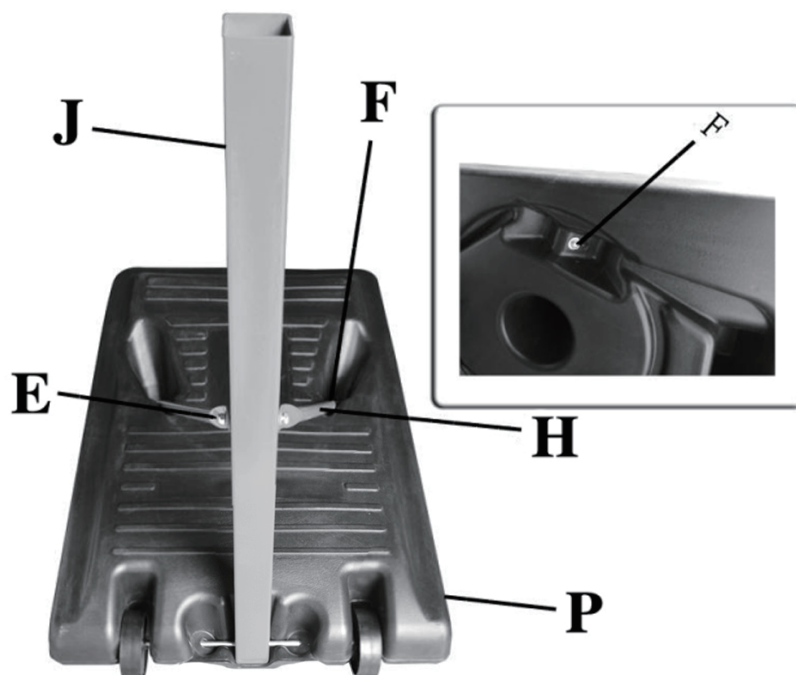

Paso 2: Montaje de la base

Fije un extremo de las dos abrazaderas de soporte (H) a la base con tornillos (F), luego fije otro extremo de las dos abrazaderas de soporte (H) en el tubo inferior (J) usando los tornillos (E) como se muestra. Termine llenando la base con agua o arena, manteniendo la base equilibrada.

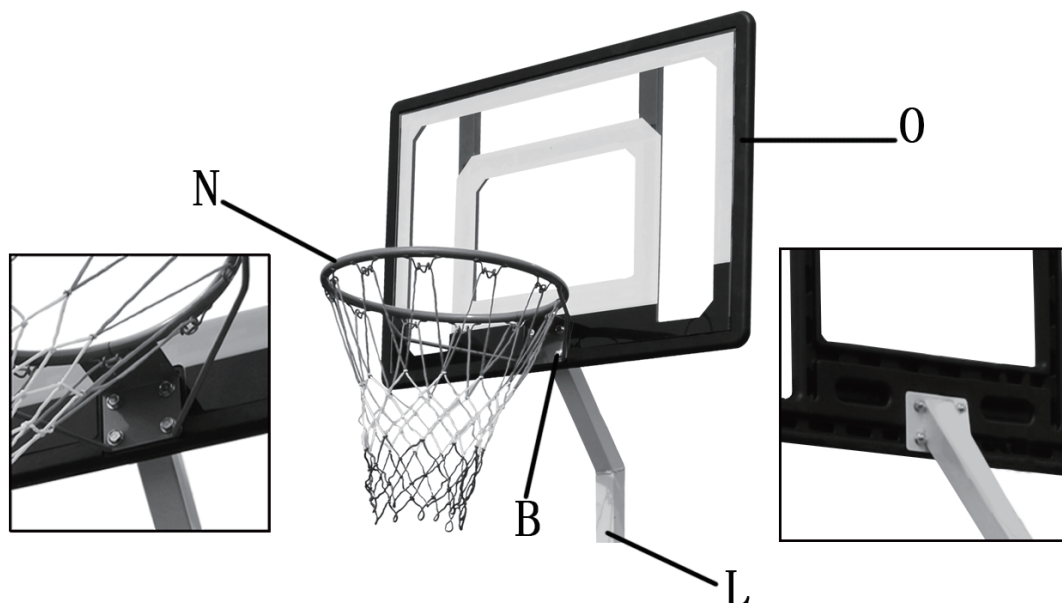

Paso 3: Montaje del aro, el tablero y el tubo superior

Monte el aro (N), el tablero trasero (0) y el tubo superior (L) usando tornillos (B) como se muestra.

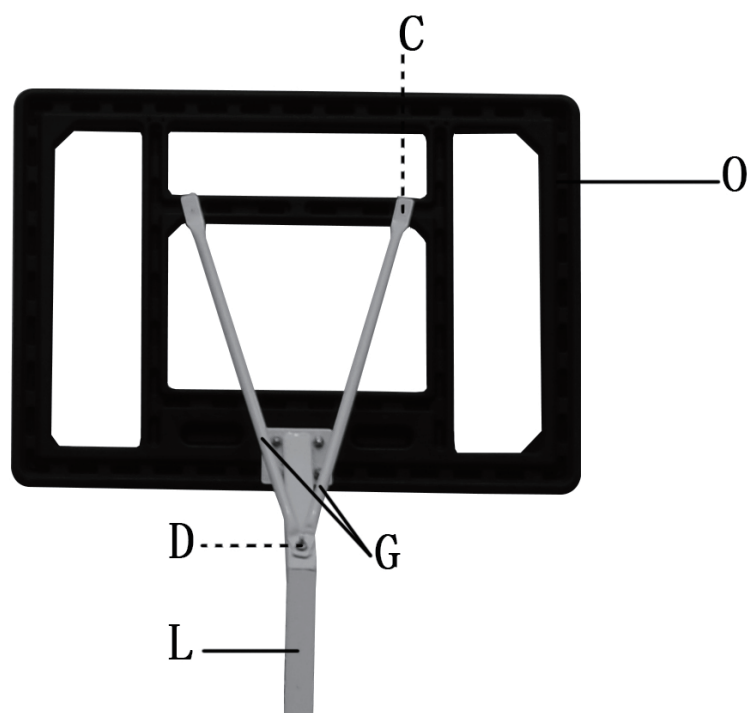

Paso 4: Montaje de las abrazaderas del tablero

Fije un extremo de la abrazadera del tablero trasero (G) en el tubo superior (L) usando tornillos (D), luego fije otro extremo de la abrazadera del tablero (G) en el tablero usando tornillos (C) como se muestra.

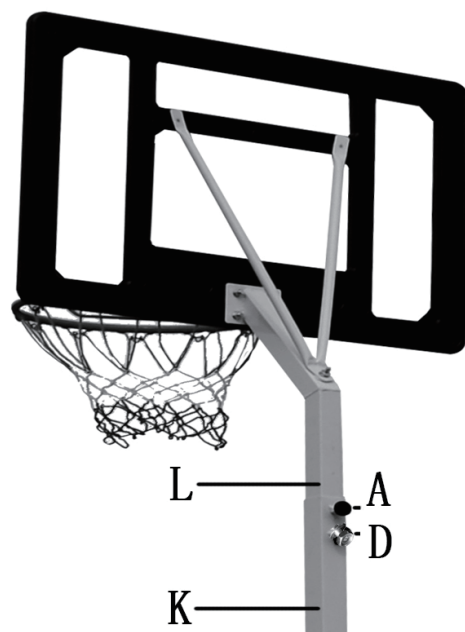

Paso 5: Montaje del tubo superior y del medio
Inserte el tubo superior (L) en el tubo central (K). La altura es ajustable. Bloquee los tubos con la perilla (A y D) como se muestra.
Aviso: el rango de ajuste es de 2,1-2,6 m

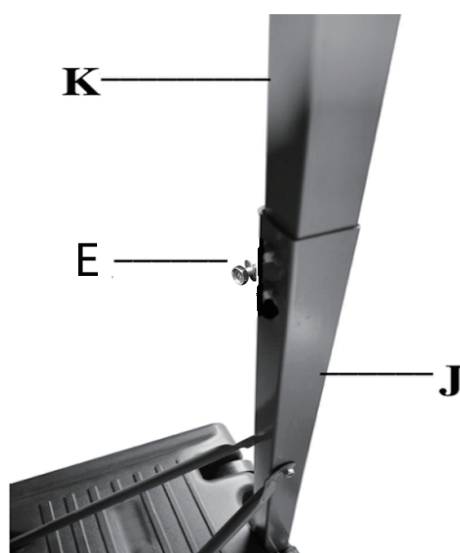

Paso 6: Montaje del tubo central y el tubo inferior
Inserte el tubo central (K) en el tubo inferior (J). Usa la perilla de plástico (E) para bloquearlos como se muestra.

Instale la red en el borde (N) como se muestra.

1.

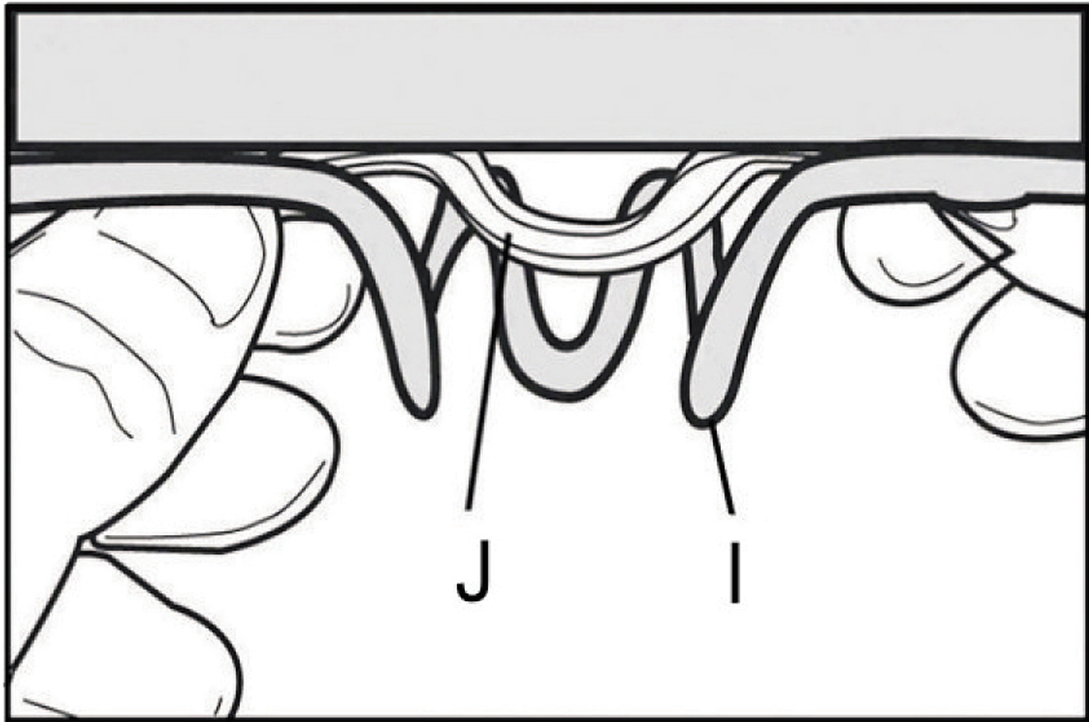

2.

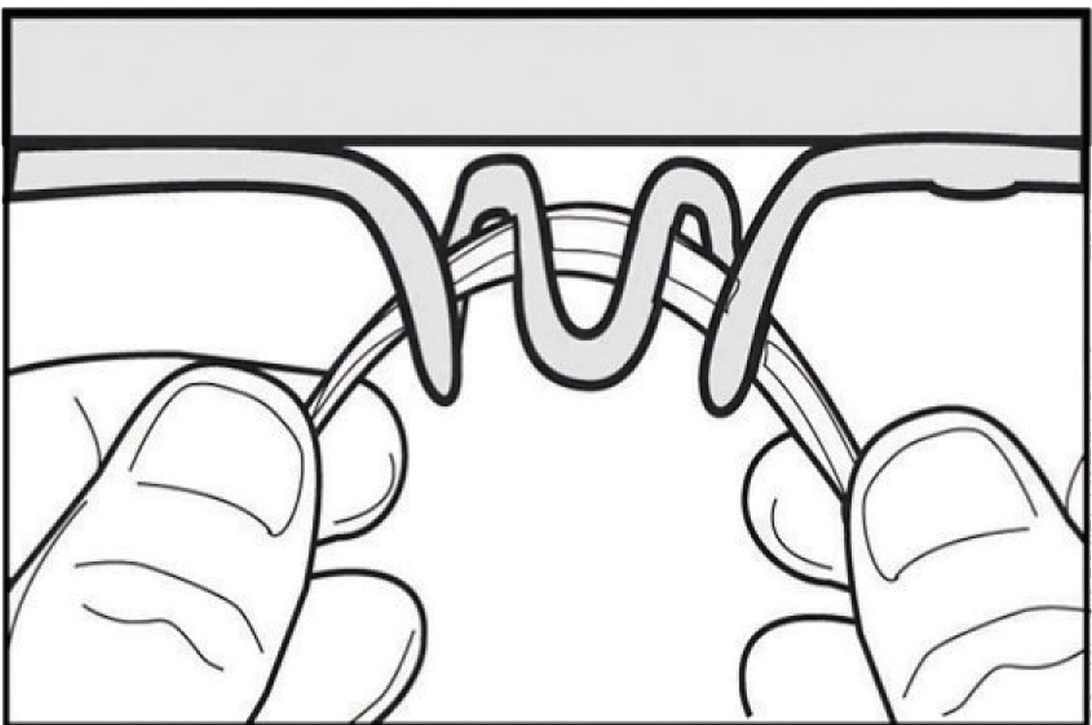

SPORTNOW

IN220800648V02_UK_ES

A61-035V00_A61-037V01_A61-037V00

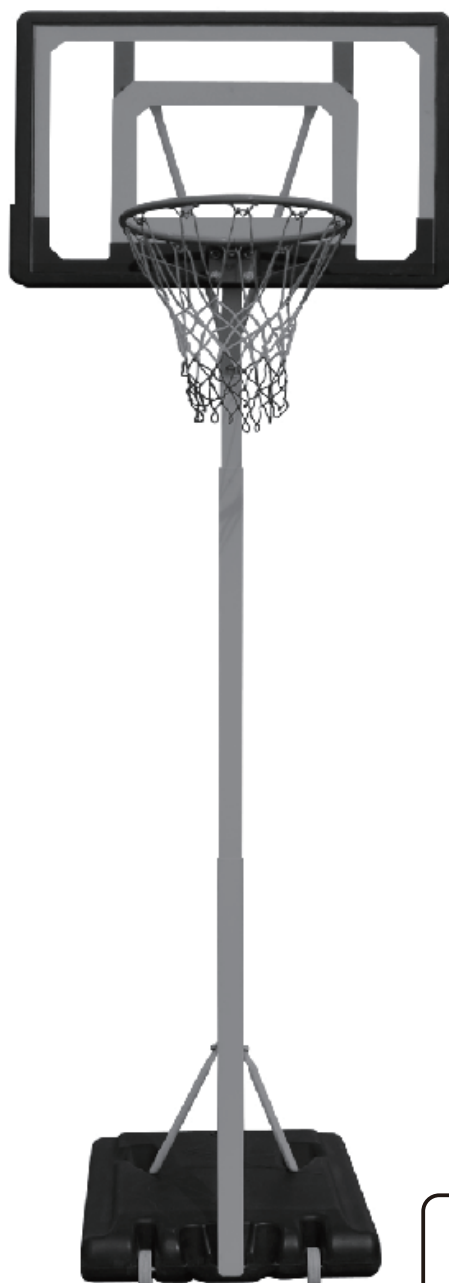

PT

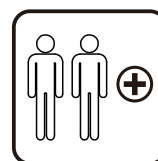
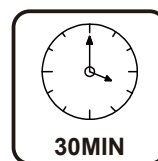
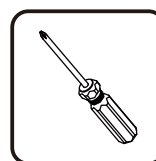

IMPORTANTE, LEIA E GUARDE PARA REFERÊNCIA FUTURA

MANUAL DE INSTRUÇÕES

INSTRUÇÕES DE SEGURANÇA

Para garantir sua segurança, não monte este produto sem seguir as instruções. Verifique a embalagem, certificando-se de que todas as peças estejam presentes e intactas. Existe um alto risco de ferimentos se este produto não for instalado, mantido e usado corretamente.

* O equipamento deve ser movimentado por pelo menos três adultos, capazes de suportar seu peso. As crianças não devem mover este aparelho.

* Verifique a base regularmente (se possível) quanto a vazamentos. Vazamentos lentos podem fazer com que o produto tombe.

* Fique na frente do produto e puxe o poste para frente para que fique equilibrado em suas rodas.

* Mova o aparelho para o local desejado e coloque cuidadosamente a base.

Advertências

1. Não o pendure na borda ou em qualquer parte do produto, incluindo a tabela traseira, suportes e rede.

2. Não use se as peças estiverem danificadas. Se houver algum problema com as peças, entre em contato com o atendimento ao cliente.

3. Não coloque o sistema na vertical sem encher a base com água, pois pode tombar e causar ferimentos.

4. Não encha a base com água em temperaturas abaixo de zero, pois a água pode congelar e causar danos. Em vez disso, use areia para preencher a base.

5. Mantenha o poste superior e o poste de elevação sempre cobertos com a tampa.

6. Ao jogar, não utilize jóias, pois podem ficar emaranhadas ou danificadas.

7. Ao ajustar a altura ou mover o produto, mantenha as mãos afastadas das peças móveis.

8. Não permita que crianças movam ou ajustem o produto.

Produto em movimento

1. Coloque o produto no nível mais baixo antes de movê-lo.

2. Evite esfregar com o chão enquanto o move.

3. Levante o produto lentamente.

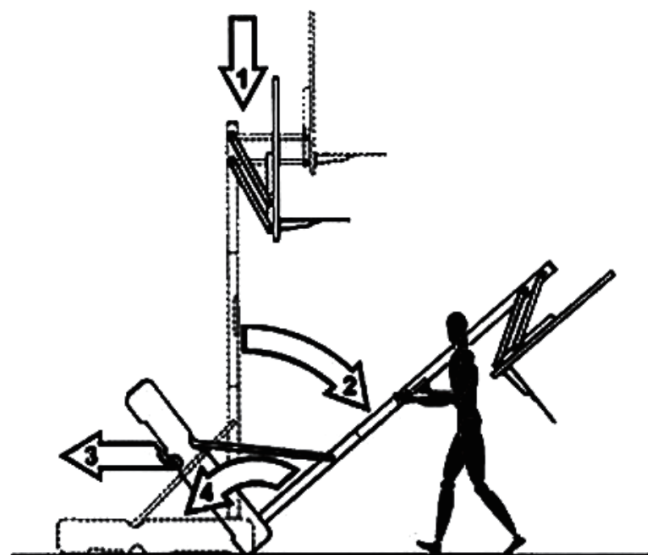

Nº	QNT.	NOME	INDICAÇÕES
A	1	M8*40MM Maçaneta de cabeça de plástico	Maçaneta de fixação poste superior (L) e poste médio (K)
B	2	M8*35MM	Conecte a borda (N), a tabela (O) e o poste superior (L)
C	2	M8*16MM	Fixar a braçadeira (G) e a tabela (O)
D	2	M8*65MM	Fixe o poste superior (L) e o poste do médio (K) Fixe o poste superior (L) e a braçadeira da tabela (G)
E	3	M8*65MM	Conecte o poste inferior (J) e a base (P)
F	2	M8*20MM	Base de conexão (P) e braçadeira de suporte (H)
G	2	Reforço da tabela	Conecte a tabela (O) e o poste superior (L)
H	2	Braçadeira de suporte	Conecte o poste inferior (J) e a base (P)
I	2	Roda	
J	1	Poste inferior	50*50MM Tubo
K	1	Poste médio	45*45MM Tubo
L	1	Poste superior	40*40MM Tubo
M	1	Eixo da roda	
N	1	Borda	
O	1	Encosto	
P	1	Base	

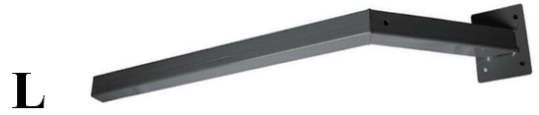
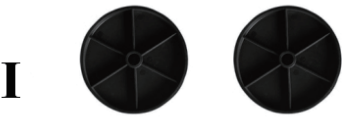
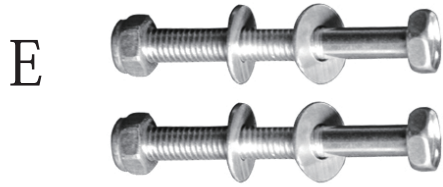

Detalhes de instalação

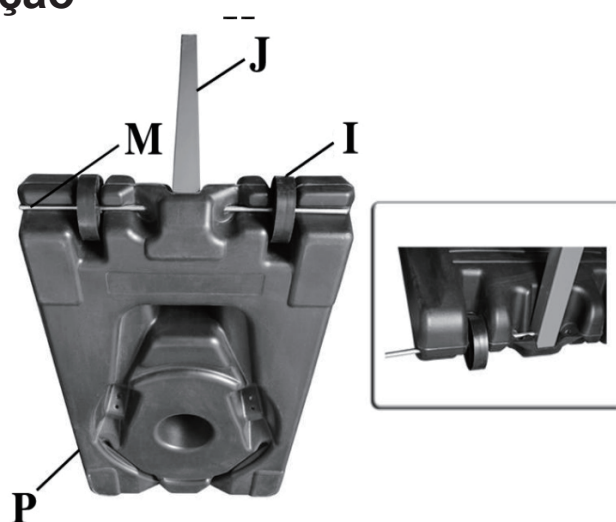

Passo 1: Monte o eixo da roda, roda e tubo inferior
Insira o eixo da roda (M) nos orifícios dianteiros da base (p), depois insira a roda esquerda (I), tubo inferior (J) e roda direita (I) como se mostra.

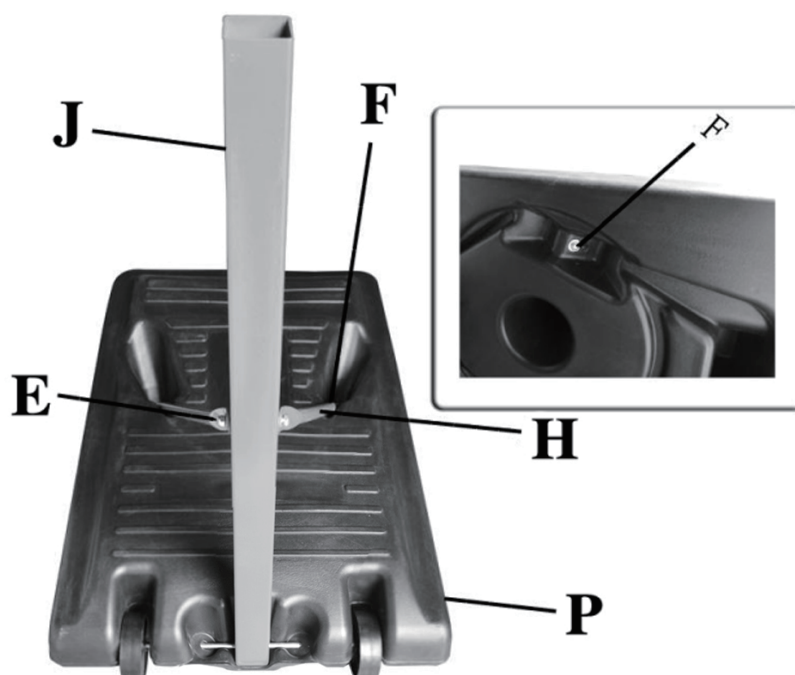

Passo 2: Montagem da base
Fixe uma extremidade das duas braçadeiras de suporte (H) à base com parafusos (F), em seguida, fixe a outra extremidade das duas braçadeiras de suporte (H) ao tubo inferior (J) usando os parafusos (E) conforme mostrado. Finalize enchendo a base com água ou areia, mantendo a base equilibrada.

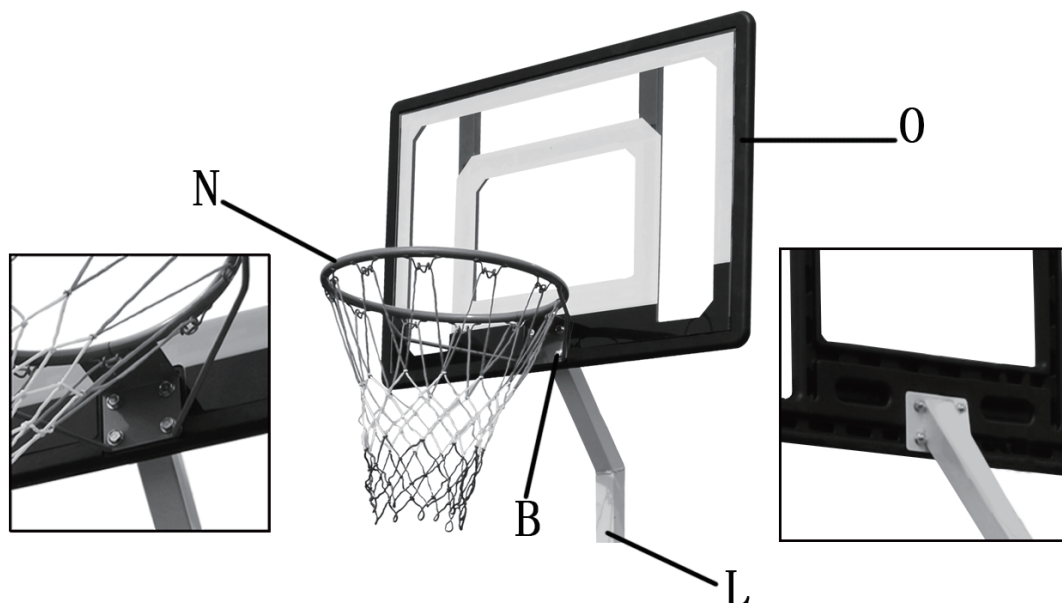

Passo 3 - Montagem do aro, tabela e tubo superior

Monte o aro (N), a tabela traseira (O) e o tubo superior (L) usando parafusos (B) como se mostra.

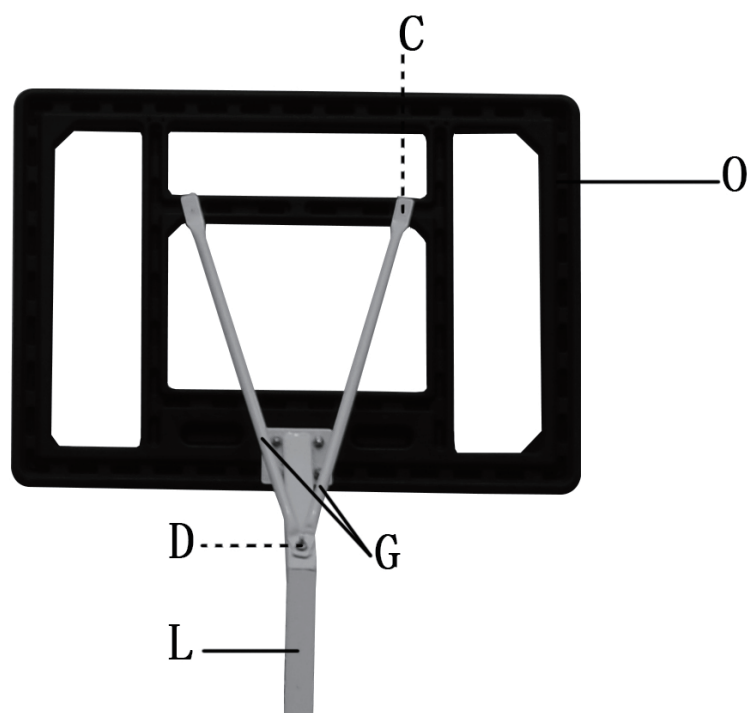

Passo 4: Montagem das braçadeiras da tabela

Conecte uma extremidade da braçadeira da tabela traseira (G) ao tubo superior (L) usando parafusos (D) e, em seguida, fixe a outra extremidade da braçadeira da tabela (G) ao painel usando parafusos (C) conforme mostrado.

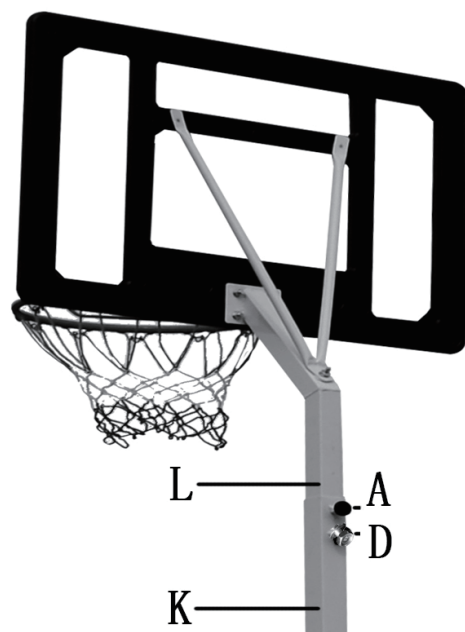

Passo 5: Montagem do tubo superior e intermediário

Insira o tubo superior (L) no tubo central (K). A altura é ajustável. Bloqueie os tubos com a maçaneta (A e D) como se mostra.

Aviso: A faixa de ajuste é 2,1-2,6 m

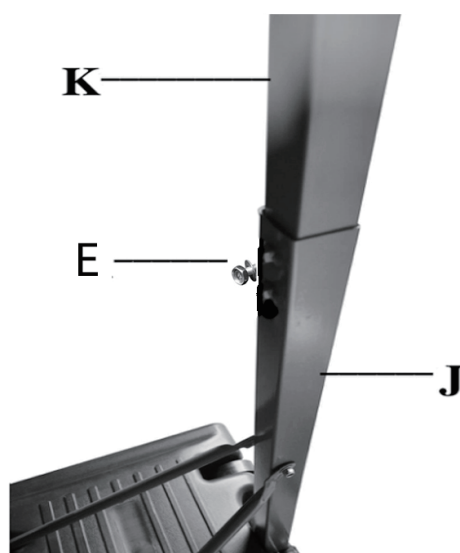

Passo 6: Montagem do tubo central e do tubo inferior

Insira o tubo central (K) no tubo inferior (J). Use a maçaneta de plástico(E) para bloqueá-los conforme mostrado.

Instale a rede na borda (N) conforme mostrado.

1.

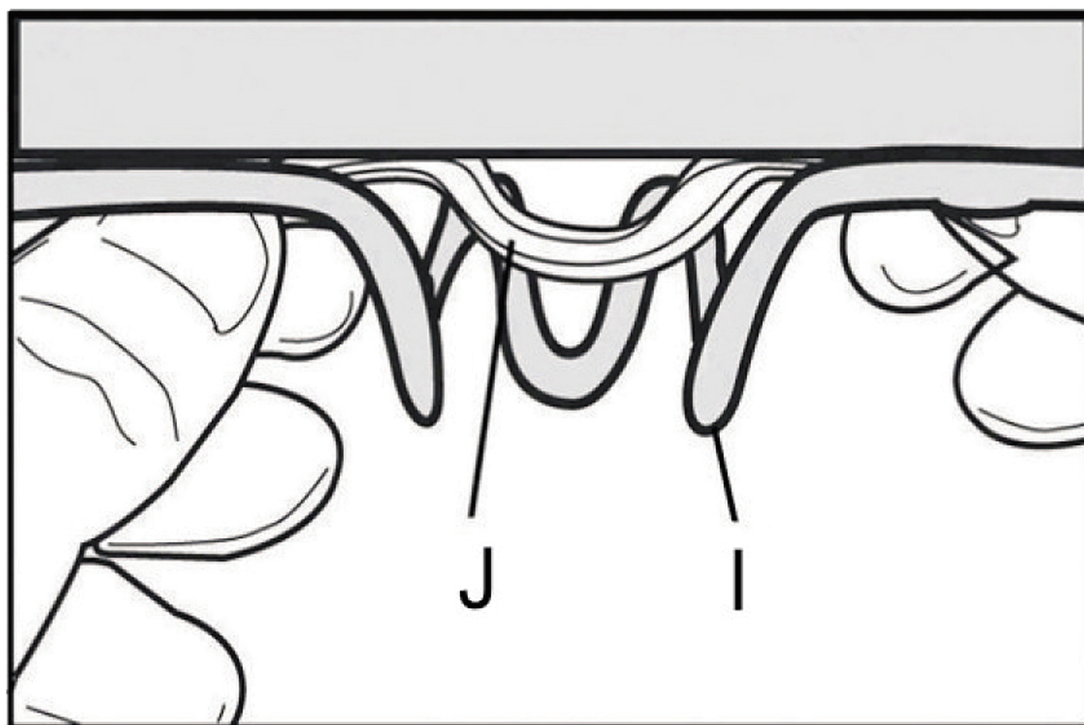

2.

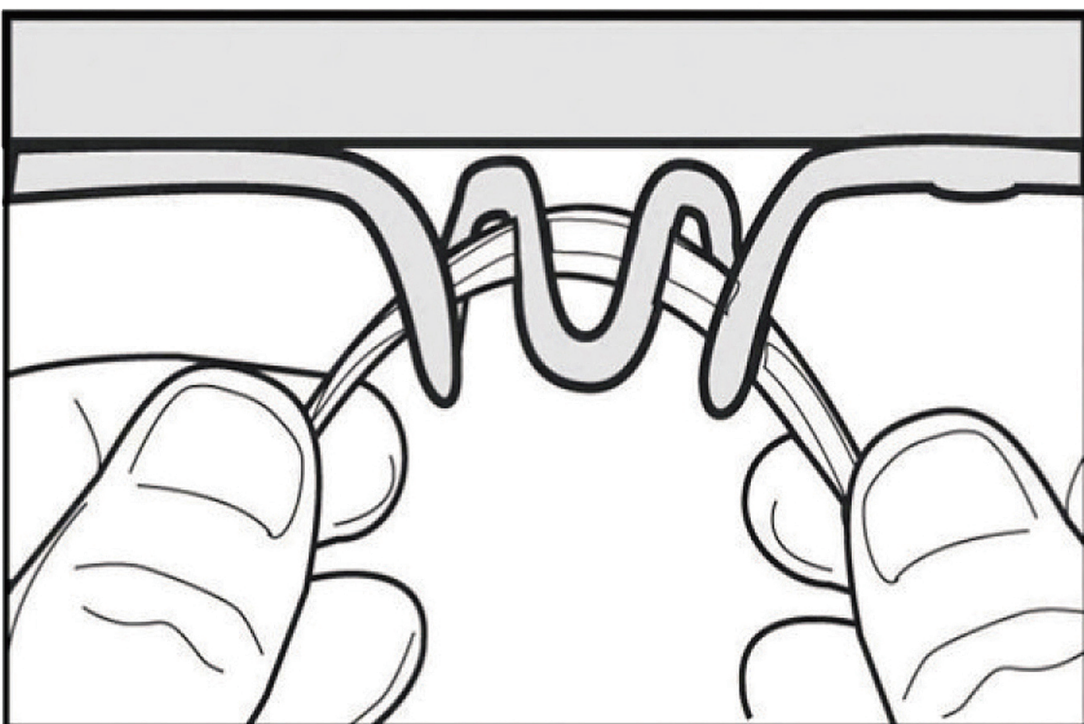

UK

If you have any questions, please contact our customer care center.

Our contact details are below:



0044-800-240-4004



enquiries@mhstar.co.uk

IMPORTER ADDRESS:

MH STAR UK LTD

Unit 27, Perivale Park,

Horsenden lane South

Perivale, UB6 7RH

MADE IN CHINA

ES

Si tiene alguna pregunta, comuníquese con nuestro Centro de Atención al Cliente. Nuestros datos de contacto son los siguientes:



0034-931294512



atencioncliente@aosom.es

IMPORTADOR:

SPANISH AOSOM, S.L.

C/ ROC GROS, N° 15. 08550, ELS HOSTALETES DE

BALENYÀ, SPAIN.

B66295775

WWW.AOSOM.ES

ATENCIONCLIENTE@AOSOM.ES

TEL: 931294512

HECHO EN CHINA

FR

Si vous avez la moindre question, veuillez contacter notre centre d'assistance à la clientèle.

Nos coordonnées sont les suivantes:



0033-1-84166106



aosom@mhfrance.fr

Importé par:

MH France

2, rue Maurice Hartmann

92130 Issy-les-Moulineaux

France

Fabriqué en Chine

PT

Se tiver alguma dúvida, por favor contacte o nosso Centro de Atendimento ao Cliente. Os nossos dados de contacto são os seguintes:



0034-931294512



info@aosom.pt.

IMPORTADOR:

SPANISH AOSOM, S.L

C.ROC GROS N.15, 08550. ELS HOSTALETES DE BALENYÀ

TEL: 931294512 (SEG-SEX DAS 7:30H ÀS 16:30H)

INFO@AOSOM.PT

WWW.AOSOM.PT

DE

Wenn Sie Fragen haben, wenden Sie sich bitte an unser Kundendienstzentrum.

Unsere Kontaktdaten stehen unten:



0049-0(40)-88307530



service@aosom.de

ADRESSE DES IMPORTEURE:

MH Handel GmbH

Wendenstraße 309

D-20537 Hamburg

Germany

IN CHINA HERGESTELLT

IT

In caso di dubbio, si prega di contattare il nostro centro assistenza clienti. I nostri dettagli di contatto sono di seguito:



0039-0249471447



clienti@aosom.it

IMPORTATO DA:

AOSOM Italy srl

Centro Direzionale Milanofiori

Strada 1 Palazzo F1

20057 Assago (MI)

P.I.: 08567220960

FATTO IN CINA