

# Vinsetto

IN220900730V01\_UK\_FR\_ES\_DE\_IT

**836-547V00**

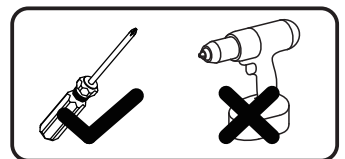
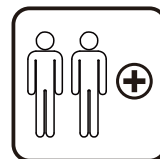
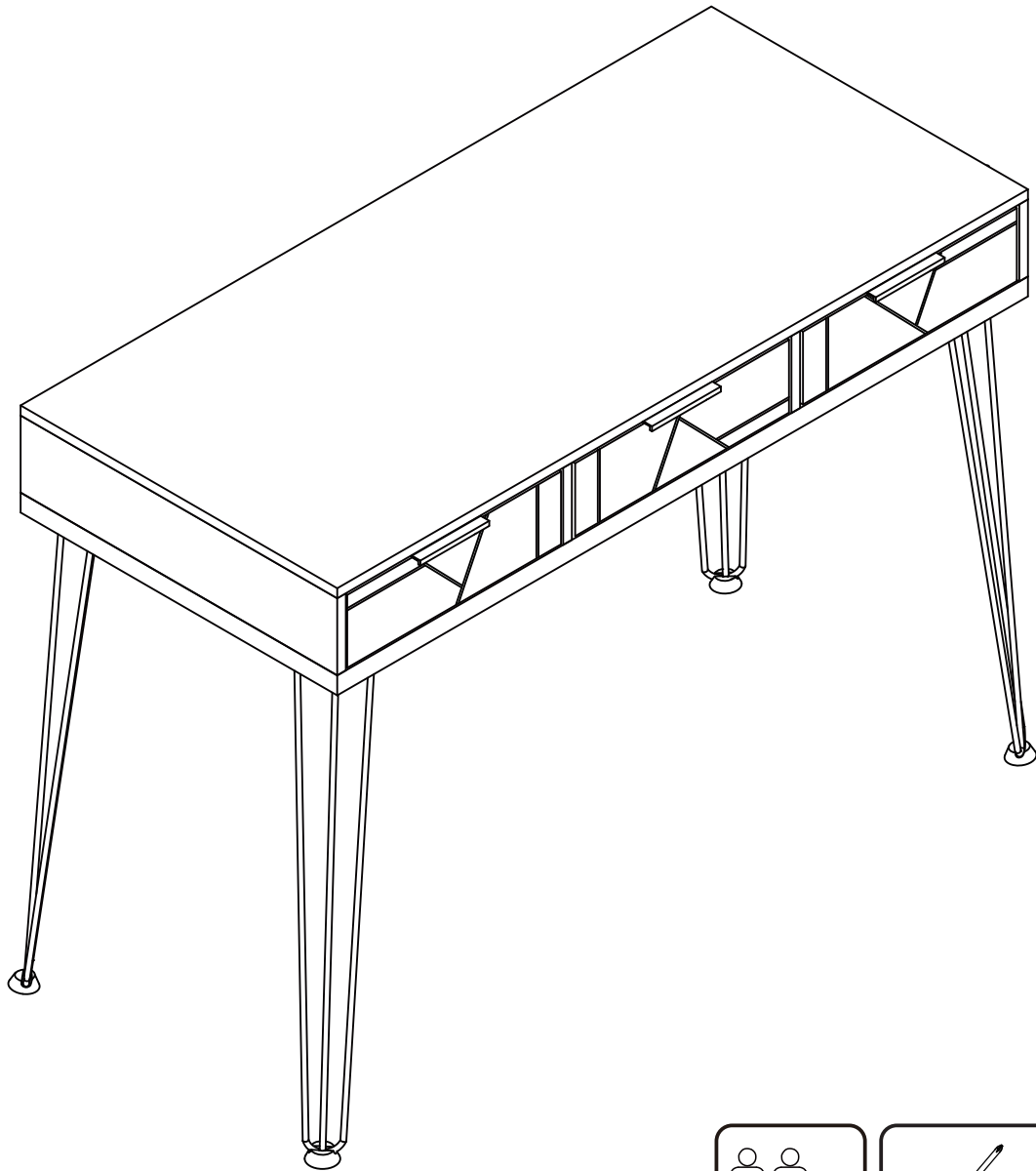

**EN\_IMPORTANT, RETAIN FOR FUTURE REFERENCE: READ CAREFULLY.**

**FR\_IMPORTANT: A LIRE ATTENTIVEMENT ET À CONSERVER POUR CONSULTATION ULTÉRIEURE.**

**ES\_IMPORTANTE, LEA Y GUARDE PARA FUTURAS REFERENCIAS.**

**DE\_„WICHTIG! SORGFÄLTIG LESEN UND FÜR SPÄTER NACHSCHLAGEN AUFBEWAHREN.“**

**IT\_IMPORTANTE! CONSERVARE IL PRESENTE MANUALE PER FUTURO RIFERIMENTO E LEGGERLO ATTENTAMENTE.**

**EN**

**Dear customer,**

Thank you for purchasing this product. So that your appliance serves you well, please read all the instructions in this user's manual. If you have any questions, please contact our customer care center.

**FR**

**Cher client,**

Nous vous remercions d'avoir acheté ce produit. Afin que vous puissiez profiter pleinement de votre appareil, veuillez lire toutes les instructions de ce manuel d'utilisation. Si vous avez la moindre question, veuillez contacter notre centre d'assistance à la clientèle.

**DE**

**Sehr geehrter Kunde,**

Vielen Dank, dass Sie dieses Produkt erworben haben. Damit Ihr Gerät Ihnen gute Dienste leistet, lesen Sie bitte alle Hinweise in diesem Benutzerhandbuch. Wenn Sie Fragen haben, wenden Sie sich bitte an unser Kundendienstzentrum.

**ES**

**Queridos clientes,**

Gracias por comprar este producto. Para que su electrodoméstico le sirva mejor, lea todas las instrucciones de este manual del usuario. Si tiene alguna pregunta, comuníquese con nuestro Centro de Atención al Cliente.

**PT**

**Caros clientes,**

Obrigado por adquirir este produto. Para que o seu aparelho o sirva melhor, leia todas as instruções deste manual do utilizador. Se tiver alguma dúvida, por favor contacte o nosso Centro de Atendimento ao Cliente.

**IT**

**Caro Cliente,**

Grazie per aver acquistato questo prodotto. Per servirti meglio con questo apparecchio ti prego di leggere tutte le istruzioni in presente manuale utente. In caso di dubbio, si prega di contattare il nostro centro assistenza clienti.

**EN\_Our contact details are below:**



**FR\_Nos coordonnées sont les suivantes:**

**DE\_Unsere Kontaktdaten stehen unten:**

**ES\_Nuestros datos de contacto son los siguientes:**

**PT\_Os nossos dados de contacto são os seguintes:**

**IT\_I nostri dettagli di contatto sono di seguito:**

Country	 Phone	 Email
UK	0044-800-240-4004	enquiries@mhstar.co.uk
DE	0049-0(40)-88307530	service@aosom.de
FR	0033-1-84166106	aosom@mhfrance.fr
ES&PT	0034-931294512	atencioncliente@aosom.es
IT	0039-0249471447	clienti@aosom.it

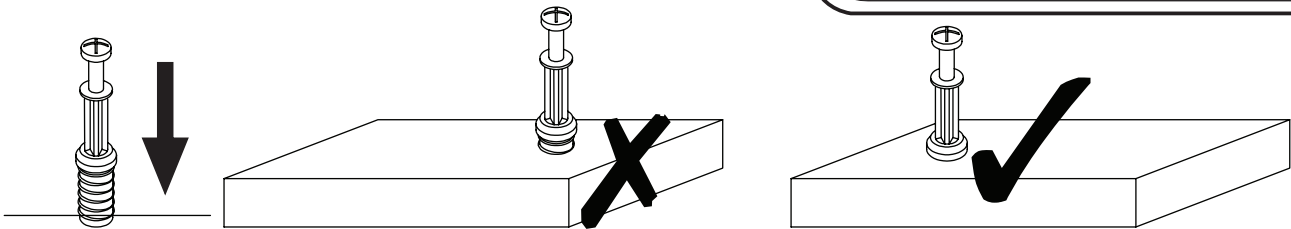

**EN\_QUICKFIT:** Tighten quickfit until shoulder is flush with panel. Do not overtighten or undertighten.

**FR\_RACCORD RAPIDE:** Faites serrer le raccord rapide jusqu'à ce que l'épaulement soit parfaitement encastré dans le panneau. Il ne faut ni trop serrer ni insuffisamment serrer.

**ES\_QUICKFIT:** Apriete quickfit hasta que el hombro se descargue con el panel. NO lo sobreapriete ni lo apriete poco.

**DE\_QUICKFIT:** Ziehen Sie den Quickfit fest, bis die Schulter mit der Platte bündig ist. Bitte nicht zu fest oder zu schwach anziehen.

**IT\_MONTAGGIO RAPIDO:** Stringere il montaggio rapido fino a quando la spalla è a filo con il pannello, non stringere troppo o troppo poco.

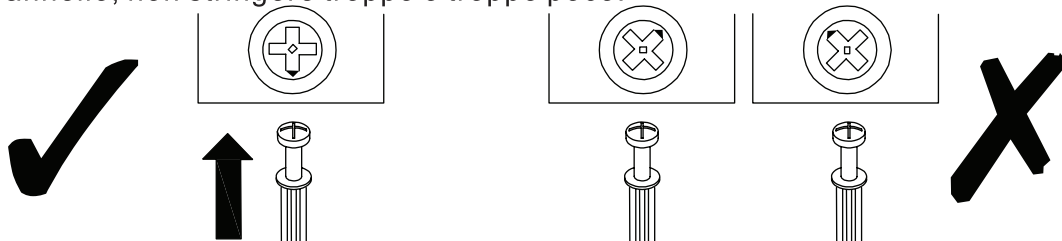

**EN\_CAM LOCK:** When fitting cam lock, ensure starting position is correct before you insert connecting quickfit.

**FR\_SERRURE BATTEUSE:** Avant d'insérer la serrure batteuse, veillez à la bonne orientation avant d'insérer le raccord rapide.

**ES\_CIERRE DE LA CÁMARA:** Cuando instale el cierre de la cámara, asegúrese de que la posición de inicio es correcta antes de que inserte el quickfit conector.

**DE\_CAM-LOCK:** Achten Sie bei der Montage des Cam-Locks auf die richtige Ausgangsposition, bevor Sie den Quickfit einsetzen.

**IT\_BLOCCAGGIO A CAMMA:** Quando si monta il bloccaggio a camma, assicurarsi che la posizione iniziale sia corretta prima di inserire il montaggio rapido di collegamento.

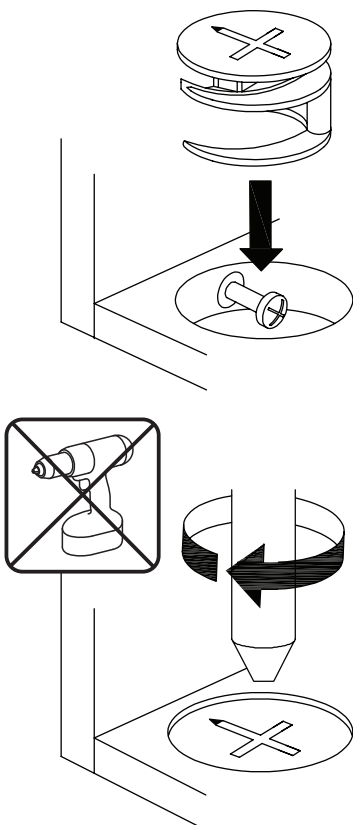

**EN\_Quickfit head** should be in the centre of the cam lock when the two panels are joined.

Cam lock should be inserted before quickfit.

**FR\_**Lorsque les deux panneaux sont assemblés, la tête du raccord rapide doit reposer au centre de la serrure batteuse.

Il faut insérer la serrure batteuse avant le raccord rapide.

**ES\_**El cabezal del quickfit debe estar en el centro del cierre de la cámara cuando se unan los dos paneles.

Se debe insertar el cierre de la cámara antes que el quickfit.

**DE\_**Der Quickfit-Kopf sollte sich in der Mitte des Cam-Locks befinden, wenn die beiden Platten zusammengefügt sind.

Der Cam-Lock sollte vor dem Quickfit eingesetzt werden.

**IT\_**La testa del montaggio rapido deve trovarsi al centro del bloccaggio a camma quando i due pannelli sono uniti.

Il Bloccaggio a Camma deve essere inserito prima del montaggio rapido.

**EN\_**Turn cam lock clockwise to tighten.





**FR\_**Faites tourner la serrure batteuse dans le sens des aiguilles d'une montre pour la resserrer.



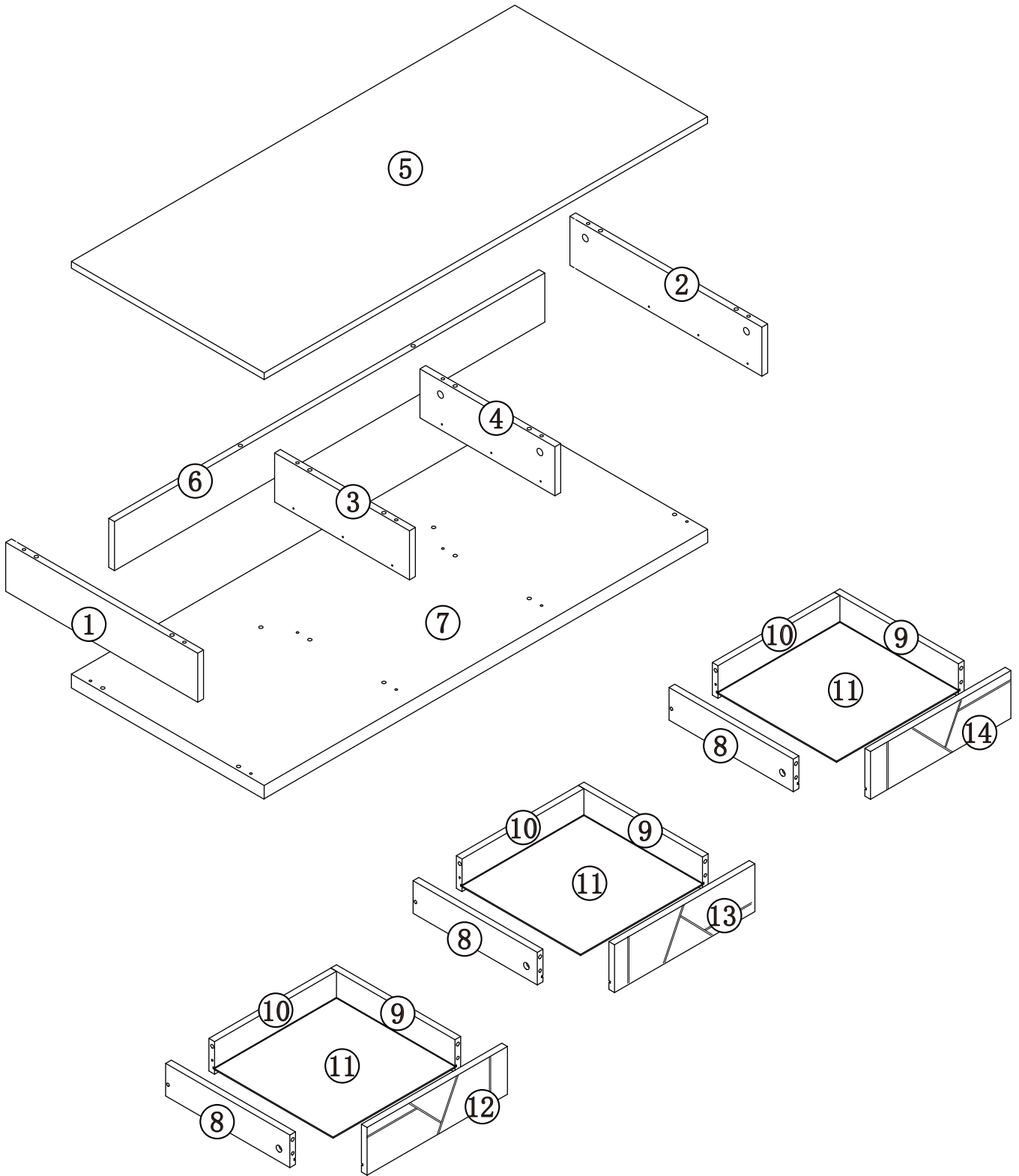

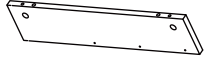
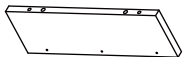
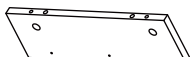

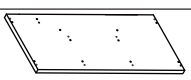
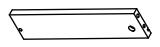
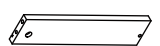

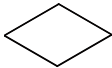
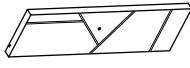
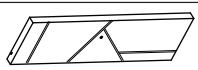
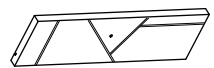

**ES\_**Gire el cierre de la cámara en sentido horario para apretarlo.

**DE\_**Drehen Sie den Cam-Lock im Uhrzeigersinn, um ihn festzuziehen.

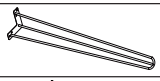
**IT\_**Ruotare il bloccaggio a camma in senso orario per stringere.

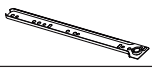

PART NO.	PARTS	QTY
①		x1
②		x1
③		x1
④		x1
⑤		x1
⑥		x1
⑦		x1
⑧		x3
⑨		x3
⑩		x3
⑪		x3
⑫		x1
⑬		x1
⑭		x1

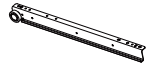
PART NO.	PARTS	QTY
Ⓐ	 8x30mm	x32 +1(spare)
Ⓑ	 5x40mm	x 6
Ⓒ	 7x39mm	x 16 +1(spare)
Ⓓ		x 16 +1(spare)
Ⓔ	 3.5x14mm	x 36 +1(spare)
Ⓕ	 5x60mm	x 10
Ⓖ	 4x14mm	x 20 +1(spare)
Ⓗ		x 4
Ⓘ		x 2
Ⓙ		x 3
Ⓚ		x 4
ⒸⓁ		x 3
ⒸⓇ		x 3
ⒹⓁ		x 3
ⒹⓇ		x 3

**E** x12

**CL** x 2

**CR** x 2

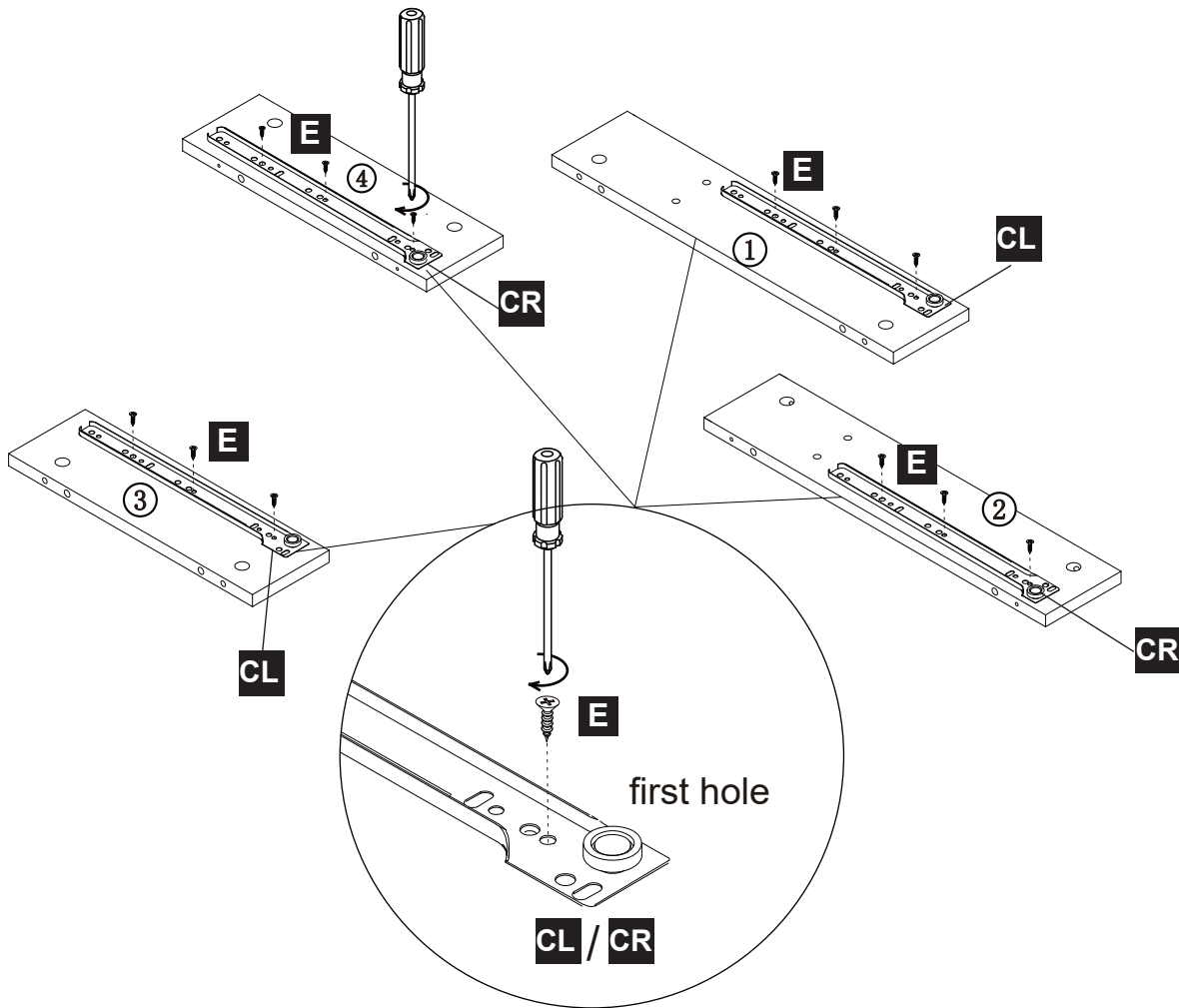

**E** x 6

**CL** x 1

**CR** x 1

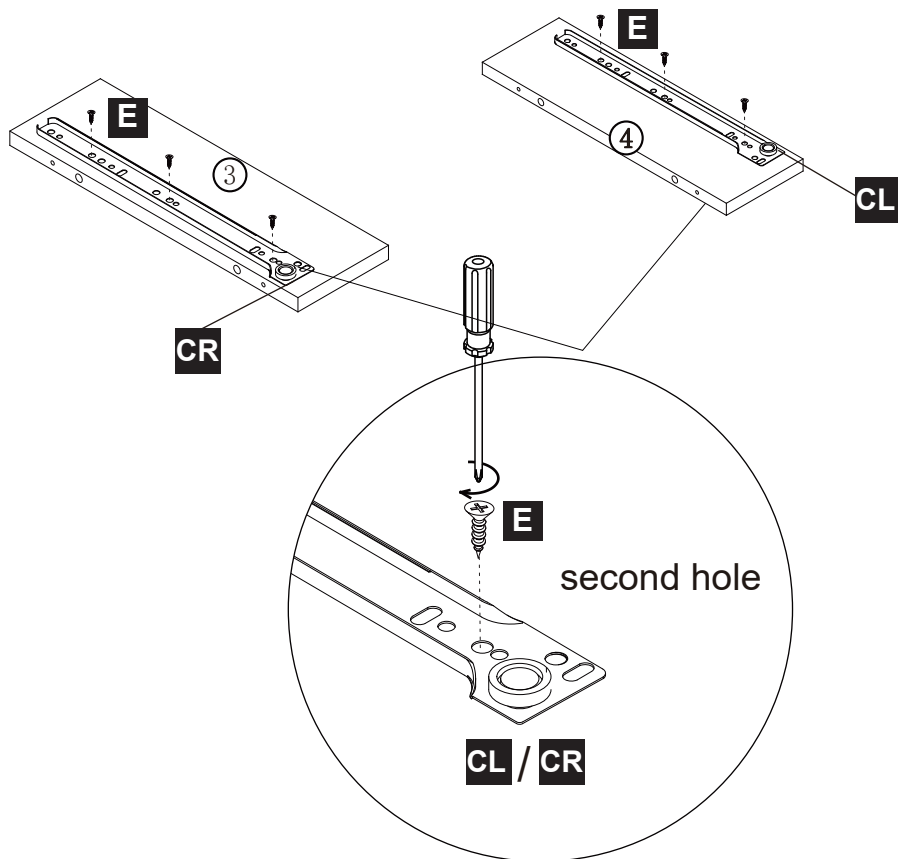

C x10

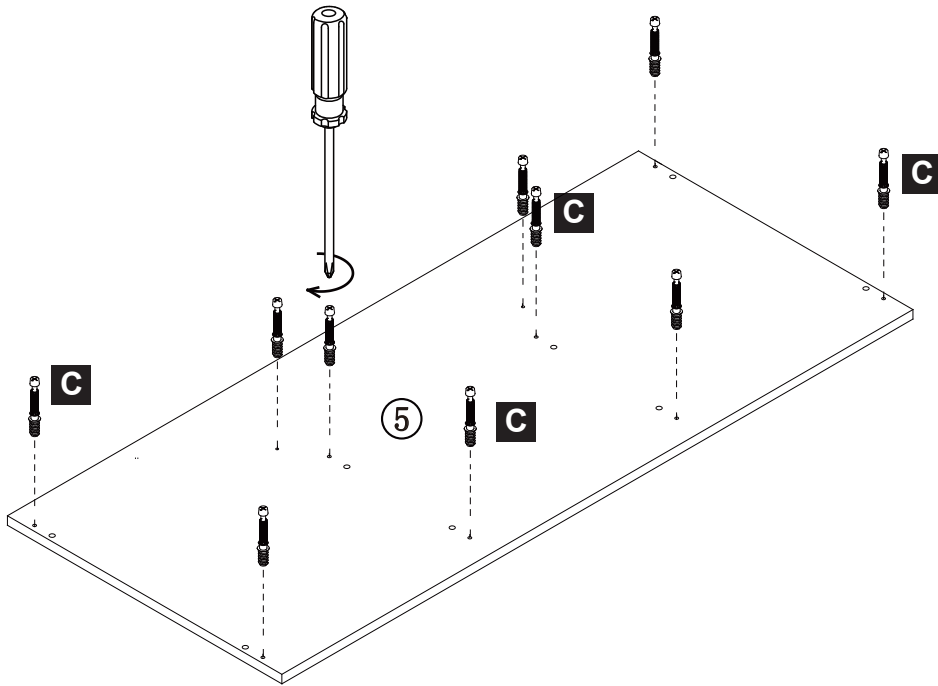

A x 4

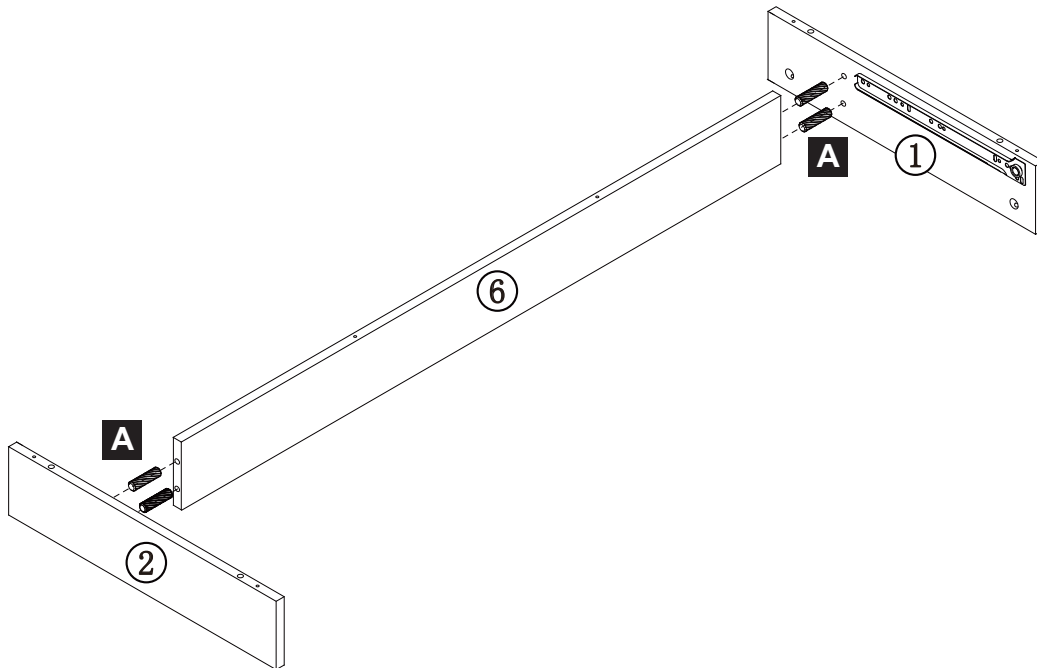

A x 8

D x 10

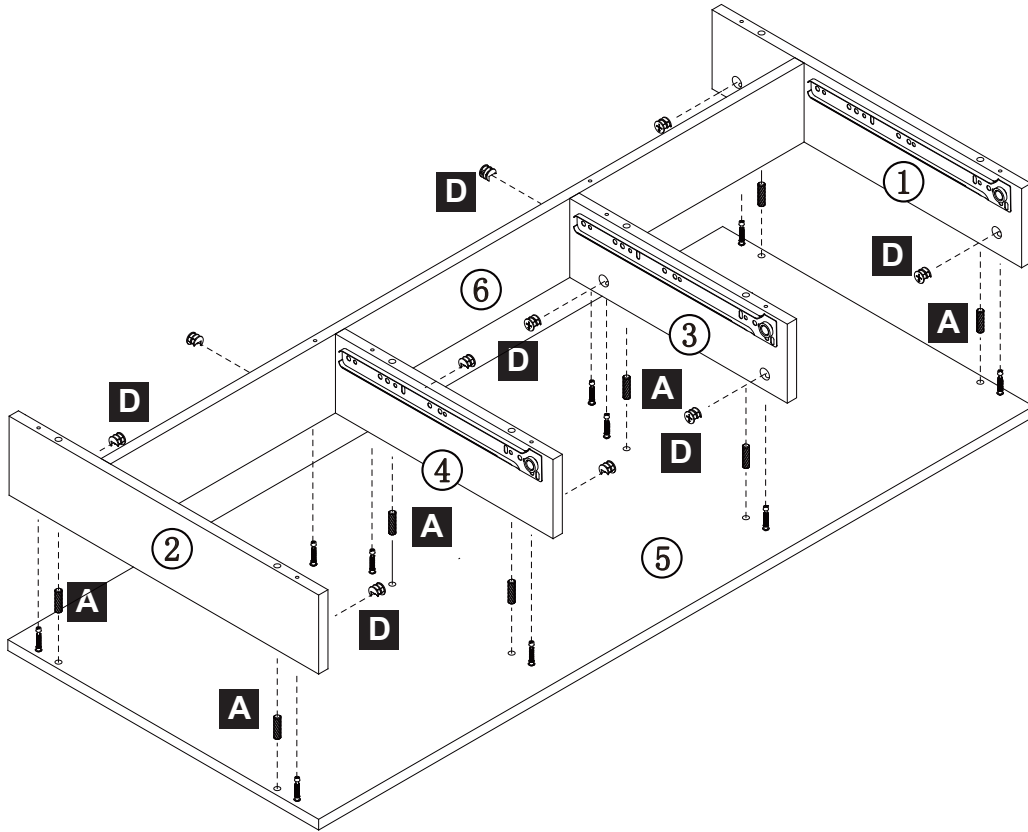

A x 8

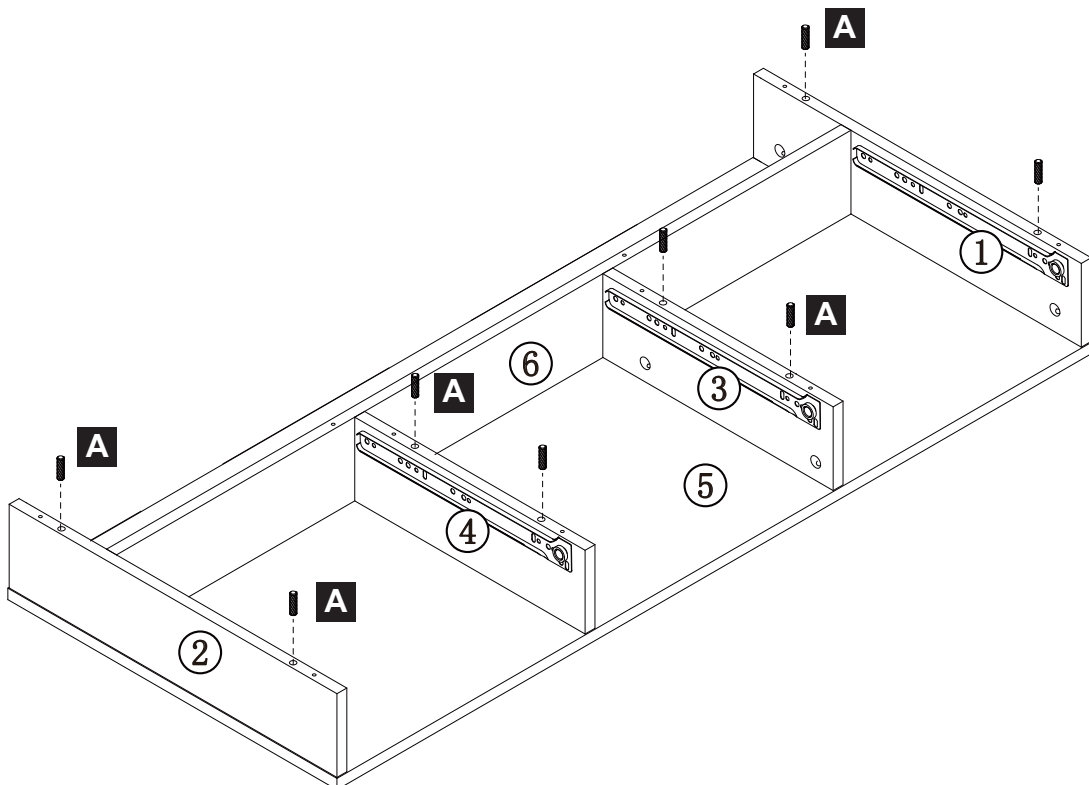



F x 10

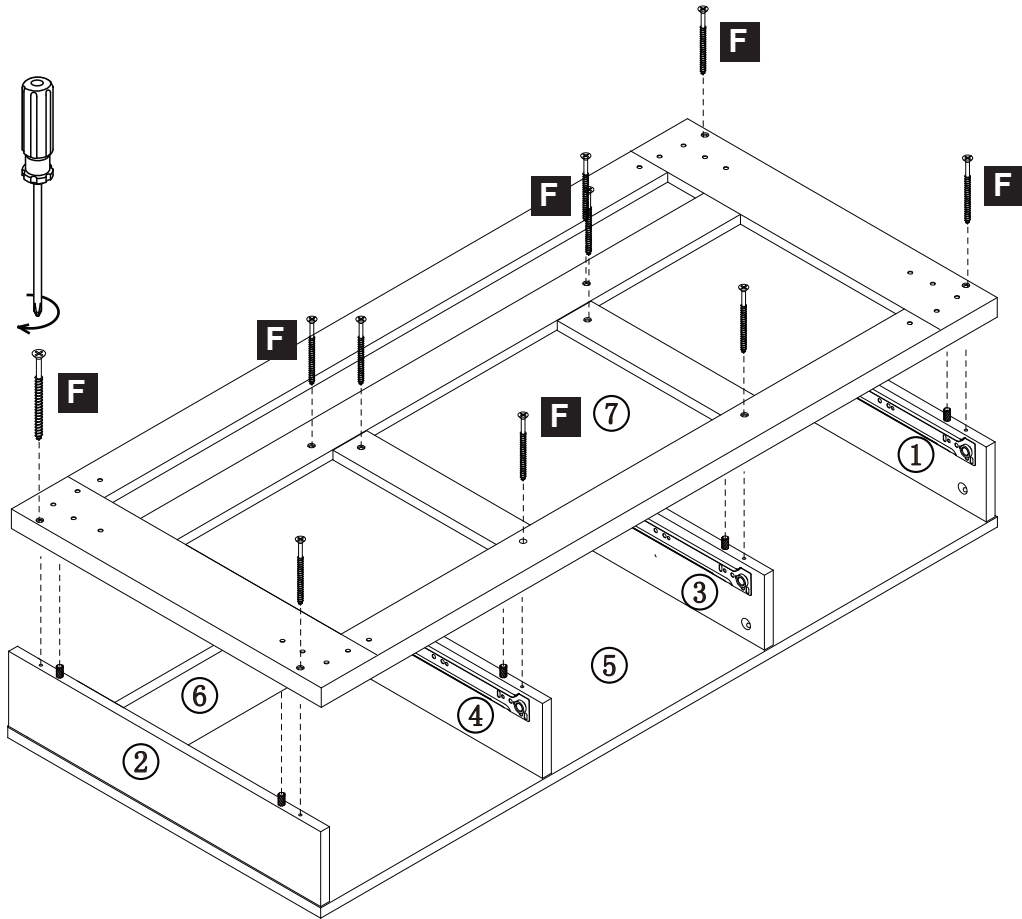

G x 20

H x 4

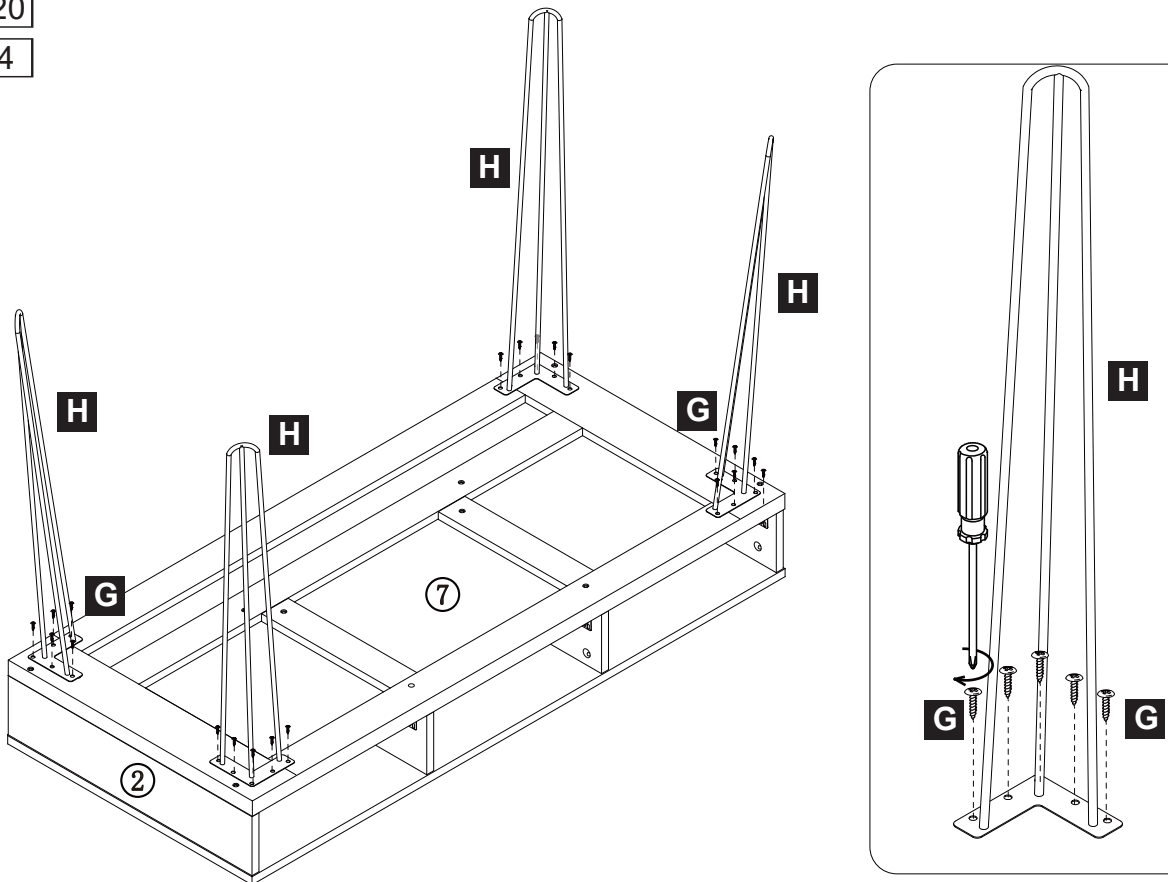

- A** x 6
- B** x 6
- C** x 6
- J** x 3

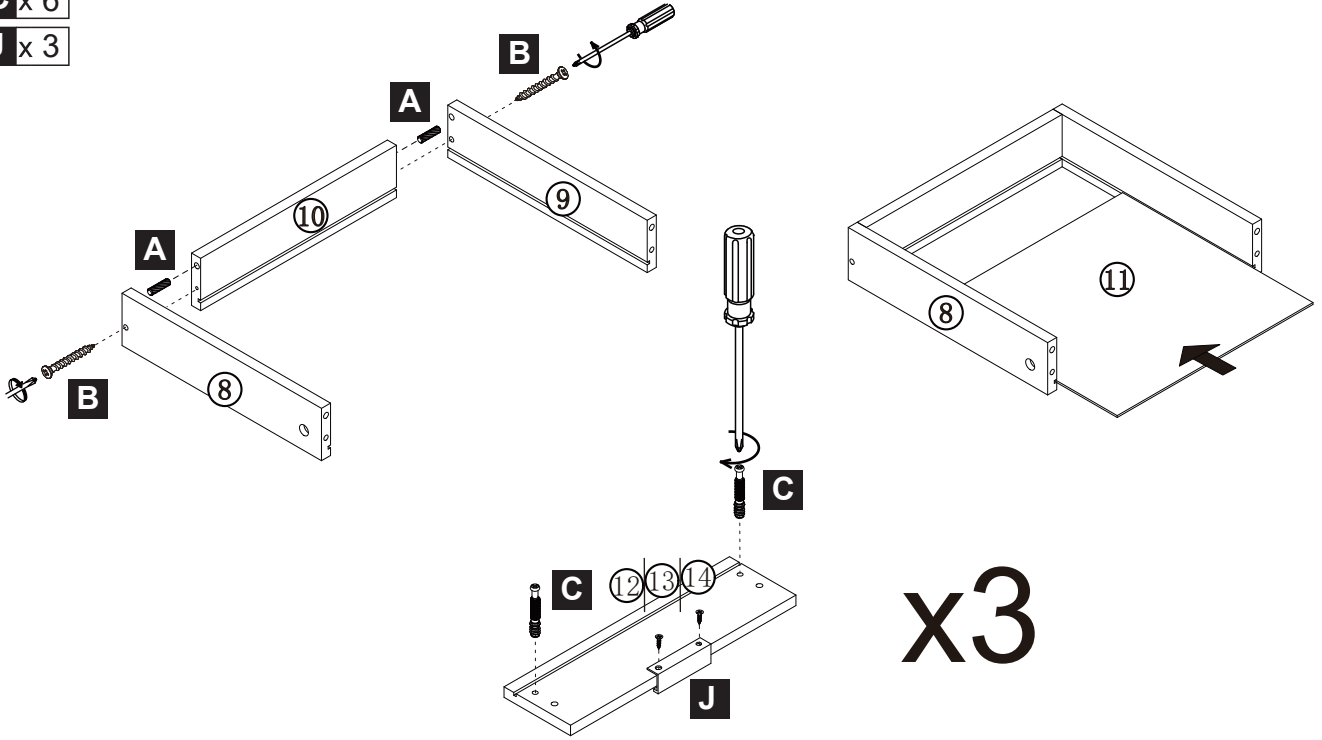

- A** x 6
- D** x 6

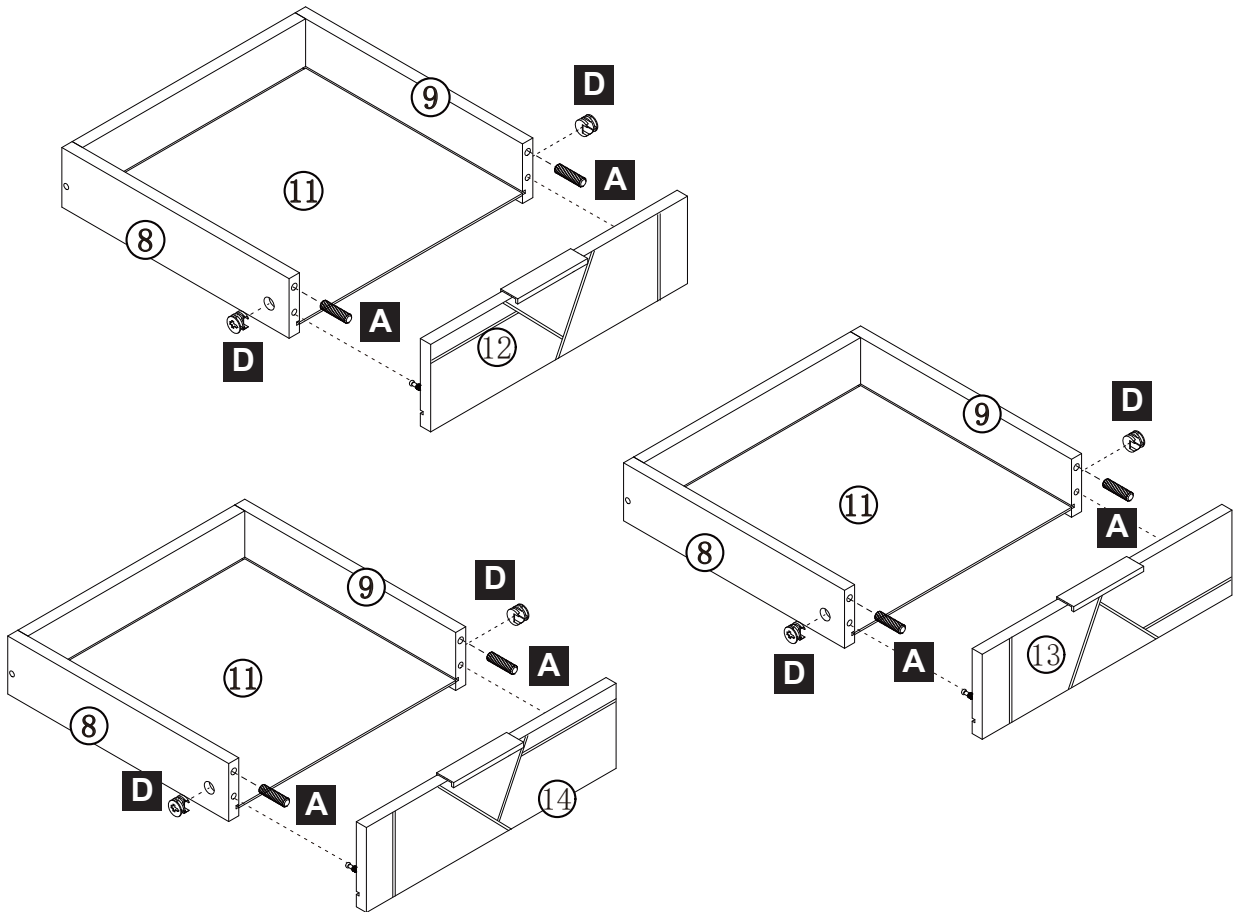

E x18

DL x 3

DR x 3

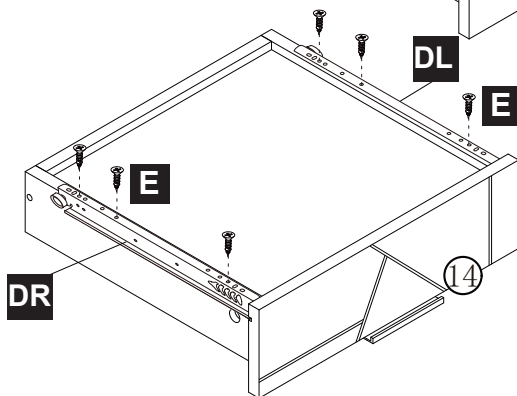
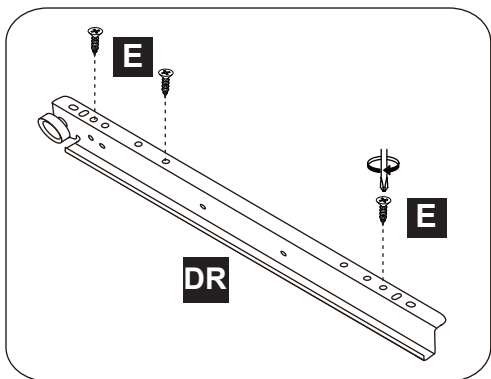
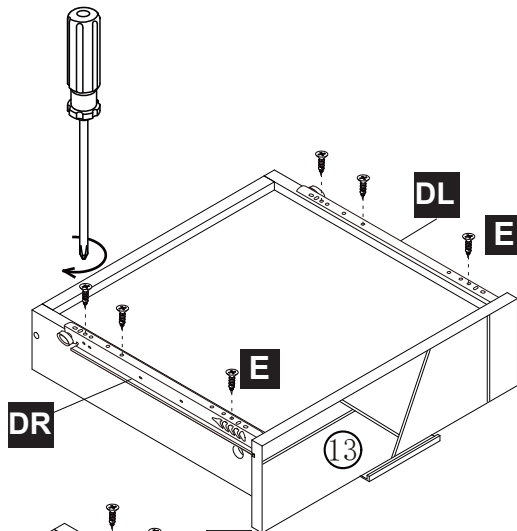
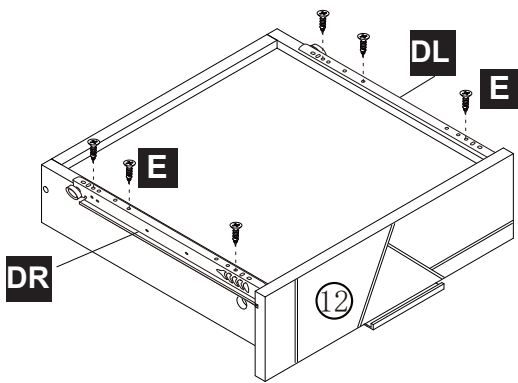

K x4

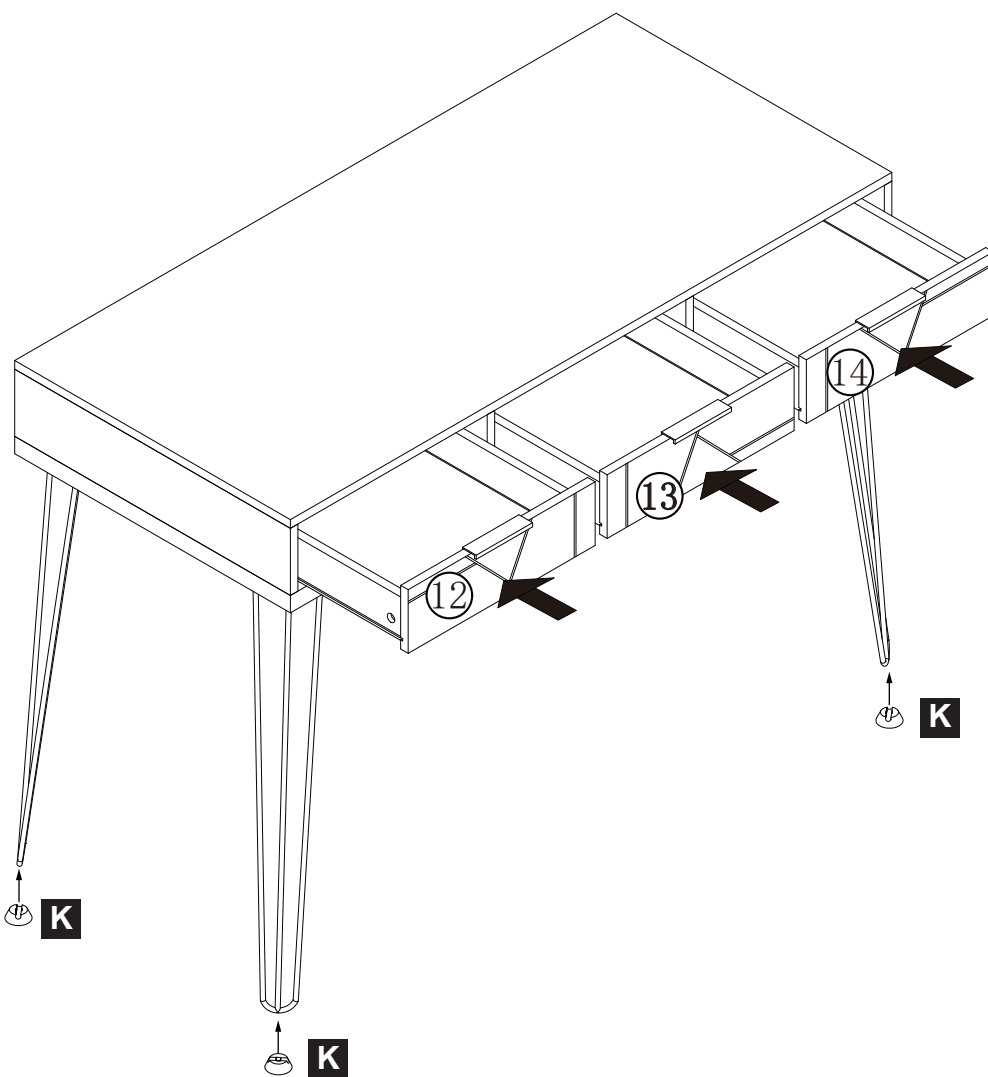

1 x 2

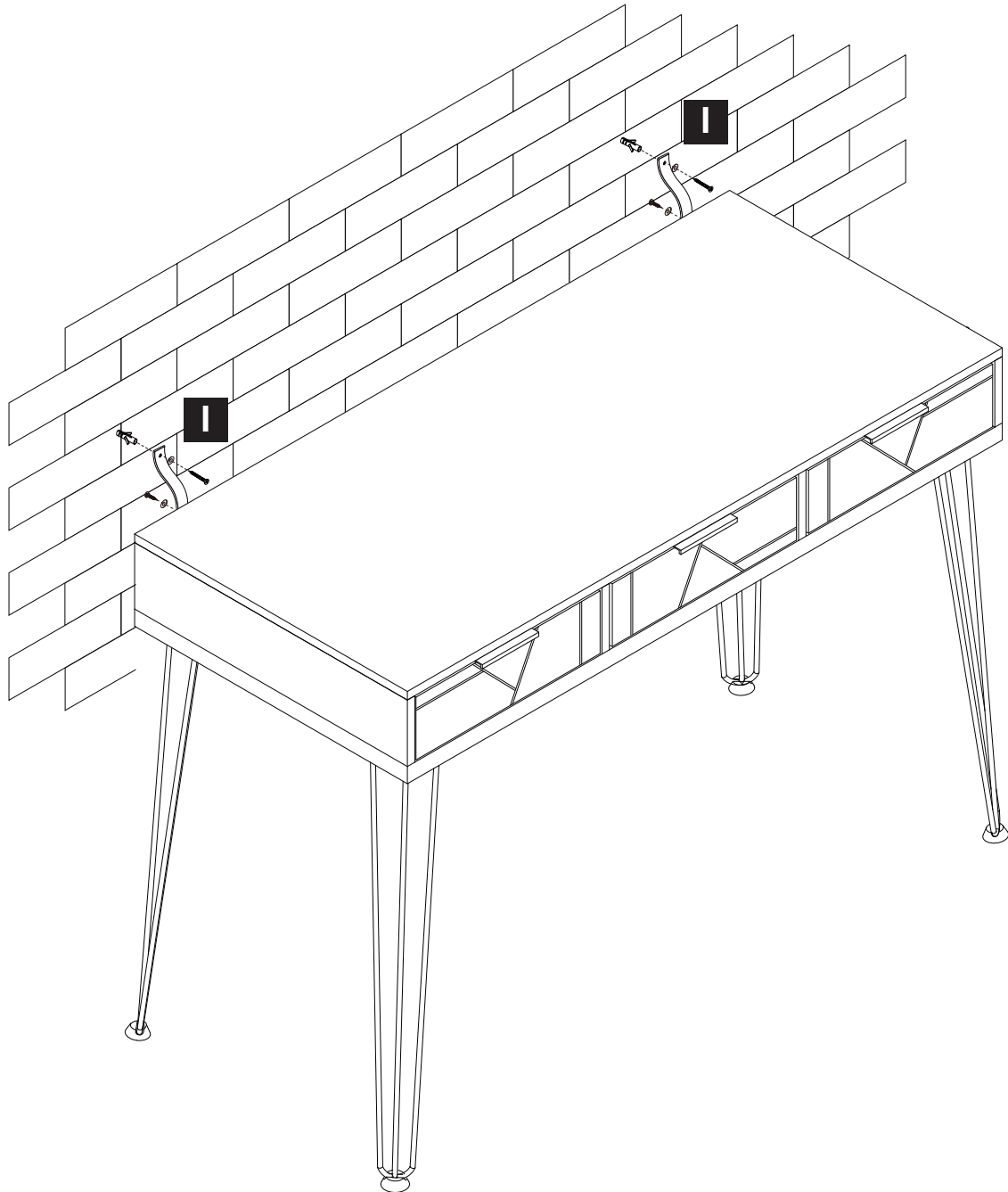

**EN** If it is a solid wall, please use expansion and self-tapping screws, if it is a wooden wall, only use self-tapping screws, please do not overtighten the screws

**FR** Si le mur est massif, veuillez utiliser des chevilles à expansion et des vis autotaraudeuses, mais s'il s'agit d'un mur en bois, utilisez uniquement des vis autotaraudeuses et ne serrez pas trop les vis.

**ES** Para una pared sólida, utilice los tornillos de expansión y autorroscantes. Para una pared de madera, utilice exclusivamente los tornillos autorroscantes, no los apriete demasiado.

**DE** Wenn es sich um eine Massivwand handelt, verwenden Sie bitte Dehnungs- und selbstschneidende Schrauben. Wenn es sich um eine Holzwand handelt, verwenden Sie nur selbstschneidende Schrauben, bitte ziehen Sie die Schrauben nicht zu fest an.

**IT** Se si tratta di un muro solido, utilizzare sia viti ad espansione che autofilettanti. Se si tratta di una parete in legno, utilizzare solo viti autofilettanti, non stringere eccessivamente le viti.

**INTENDED USE IN OFFICE OR HOME  
ABOUT CARE AND MAINTENANCE OF TABLE :**

1. To prevent the table from being scratched by hard objects, do not let metal objects break the surface of the table and leave bruise marks.
- 2, do not let the heat source has been baking, away from the source of fire. The surface should be fully considered to prevent dry cracking and deformation.
3. When in use, pay attention to the placement in a stable environment, otherwise there will be deformation.
- 4, prevent direct sunlight, can use gauze to prevent sunlight, so not only does not affect day lighting, but also can maintain the desk.
- 5, to check the desk, regularly clean up, remove the dust and corrosive gas and liquid, to prevent the desk  
Corrosion affects the whole integrity of the table.
- 6, when using water to wipe the desktop, to wipe it clean, do not leave moisture on the desktop.
- 7, when cleaning to use a clean soft cloth, do not be too hard to wipe.

**UTILISATION PRÉVUE POUR LE BUREAU OU LA MAISON  
À PROPOS DE L'ENTRETIEN ET DE LA MAINTENANCE DE LA  
TABLE :**

1. Pour éviter que la table ne soit rayée par des objets durs, ne laissez pas d'objets métalliques briser la surface de la table et laisser des marques d'ecchymoses.
2. Ne laissez pas la source de chaleur a été la cuisson, loin de la source de feu. La surface doit être entièrement considérée pour éviter les fissures sèches et les déformations.
3. Lors de l'utilisation, assurez-vous que la table soit placée dans un environnement stable, sinon il y aura des déformations.
4. Empêcher la lumière directe du soleil, vous pouvez utiliser une gaze pour protéger le bureau de la lumière directe du soleil, de sorte que non seulement l'éclairage de jour ne soit pas affecté, mais aussi que la table soit préservée.
5. Inspecter régulièrement la table, nettoyer et enlever la poussière ainsi que les matières corrosives (gaz et liquides) afin de prévenir la corrosion de la table. La corrosion affecte l'intégrité entière de la table.
6. Lorsque vous utilisez de l'eau pour essuyer la table, nettoyez-la soigneusement, ne laissez pas de traces d'humidité sur la table.
7. Lorsque vous nettoyez le la table, utilisez un chiffon doux et propre, sans trop forcer.

## **PARA USARSE EN OFICINA Y HOGAR CUIDADO Y MANTENIMIENTO DE LA MESA:**

1. Tenga en cuenta de que los objetos duros metálicos pueden romper la superficie de la mesa y dejar marcas de magulladuras.
2. No ponga el producto cerca de la fuente de calor, y manténgalo lejos de la fuente de fuego. De lo contrario, puede producir grietas y deformaciones en la superficie.
3. Cuando no la utiliza, colóquela en un lugar estable, para evitar la deformación.
4. Puede usar una gasa para protegerla de la luz solar directa, lo cual no afecta la iluminación diurna, mientras tanto puede ofrecer protección a la mesa.
5. Regularmente revise y limpie la mesa, eliminando el polvo y las materias corrosivas, para proteger la mesa.

Las materias corrosivas pueden afectar la integridad de la mesa.

6. Después de limpiar la mesa con agua, tiene que secarla completamente. Tenga cuidado de no dejar humedad en la mesa.
7. Limpie la mesa con un paño suave y limpio, sin ejercer mucha fuerza.

## **VORGESEHENE VERWENDUNG IM BÜRO ODER ZU HAUSE ZUR PFLEGE UND WARTUNG DES TISCHES :**

1. Um zu verhindern, dass der Tisch durch harte Gegenstände zerkratzt wird, vermeiden Sie, dass Metallgegenstände die Oberfläche des Tisches beschädigen und blaue Flecken hinterlassen.
2. Entfernen Sie die Wärmequelle für das Backen nicht von der Feuerquelle. Die Oberfläche sollte vollständig berücksichtigt werden, um Trockenrisse und Verformungen zu verhindern.
3. Wenn in Gebrauch, achten Sie auf die Aufstellung in einer stabilen Umgebung, sonst gibt es Verformungen.
4. Verhindern Sie direktes Sonnenlicht, Sie können Gaze verwenden, um Sonnenlicht zu verhindern, so dass nicht nur die Tagesbeleuchtung nicht beeinträchtigt wird, sondern auch der Schreibtisch erhalten werden kann.
5. Den Schreibtisch prüfen, regelmäßig aufräumen, den Staub und korrosives Gas und Flüssigkeit entfernen, um den Schreibtisch zu schützen. Korrosion beeinträchtigt die gesamte Integrität des Tisches.
6. Wenn Sie Wasser verwenden, um den Schreibtisch zu wischen, um ihn sauber zu wischen, hinterlassen Sie keine Feuchtigkeit auf dem Schreibtisch.
7. Bei der Reinigung ein sauberes, weiches Tuch verwenden, nicht zu hart wischen.

## **DESTINAZIONE D'USO IN UFFICIO O A CASA CURA E MANUTENZIONE DELLA SCRIVANIA:**

1. Per evitare che la scrivania venga graffiata da oggetti duri, non lasciare che gli oggetti metallici rompano la superficie della scrivania e lascino le tracce.
2. Non permettere che la fonte di calore o i fornelli, tenerla lontana dalla fonte di fuoco. La superficie dovrebbe essere considerata completamente per evitare crepe e deformazioni secche.
3. Quando è in uso, prestare attenzione al posizionamento in un ambiente stabile, altrimenti si verificherà una deformazione.
4. Prevenire la luce solare diretta. Si può utilizzare una garza per prevenire la luce solare in modo che non influisca sull'illuminazione diurna, ma possa anche mantenere la scrivania.
5. Controllare la scrivania, pulire regolarmente, rimuovere la polvere e il gas e il liquido corrosivi per mantenere la scrivania.  
La corrosione influenza l'intera integrità della scrivania.
6. Quando si utilizza l'acqua per pulire la superficie, non lasciare umidità sulla superficie.
7. Quando la pulisci, utilizza un panno morbido pulito, non pulirla con forza troppo forte.

**IMPORTER ADDRESS****EN**

MH STAR UK LTD  
Unit 27, Perivale Park,  
Horsenden lane South  
Perivale, UB6 7RH  
MADE IN CHINA

**ADRESSE D'IMPORTATION****FR**

MH FRANCE  
2 Rue Maurice Hartmann  
92130 Issy Les Moulineaux  
France  
FABRIQUÉ EN CHINE

**IMPORTADOR****ES**

SPANISH AOSOM, S.L.  
C/ ROC GROS, Nº 15. 08550, ELS HOSTALET DE BALENYÀ, SPAIN.  
B66295775  
WWW.AOSOM.ES  
ATENCIONCLIENTE@AOSOM.ES  
TEL: 931294512  
HECHO EN CHINA

**ADRESSE DES IMPORTEURE****DE**

MH Handel GmbH  
Wendenstraße 309  
D-20537 Hamburg  
Germany  
IN CHINA HERGESTELLT

**IMPORTATO DA****IT**

AOSOM Italy srl  
Centro Direzionale Milanofiori  
Strada 1 Palazzo F1  
20057 Assago (MI)  
P.I.: 08567220960  
FATTO IN CINA

**FR**

**Pensez à  
donner ou recycler.**



Association

ou



Magasin

ou



Déchèterie

<https://quefairedemesdechets.fr>