

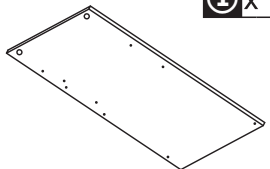









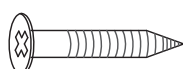
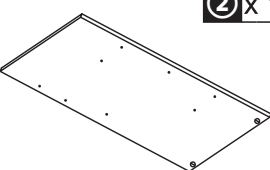

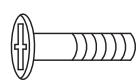
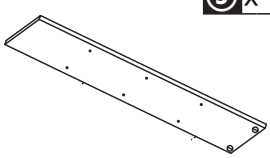
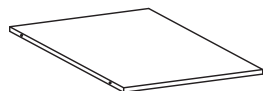

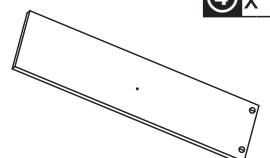

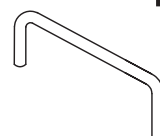

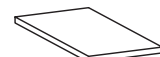



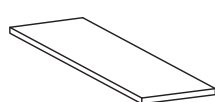



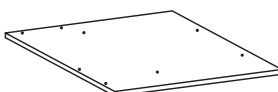
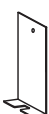
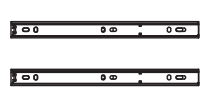
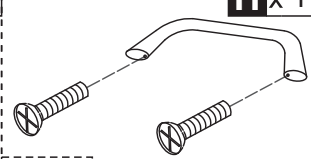
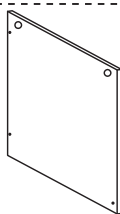
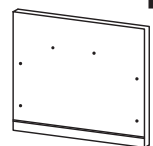
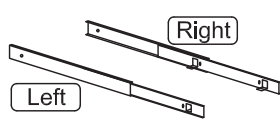
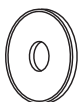
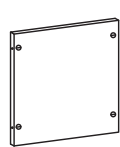
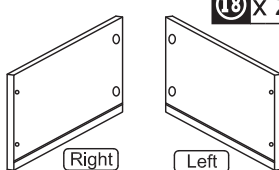
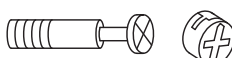

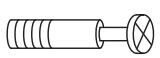
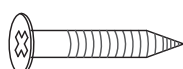

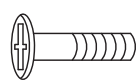

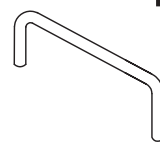
Assembly video please scan the QR code .

READ AND SAVE THIS INSTRUCTIONS FOR FUTURE USE

ASSEMBLY & INSTRUCTION MANUAL

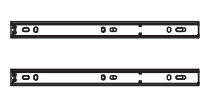
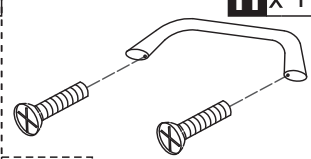
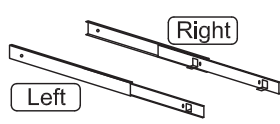
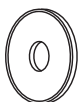
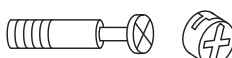
 ① x 1	 ⑩ x 1	 ⑱ x 1	 B x 33
 ② x 1	 ⑪ x 1	 ⑳ x 1	 C x 7
 ③ x 1	 ⑫ x 1	 ㉑ x 1	 D x 2
 ④ x 1	 ⑬ x 1	 ㉒ x 1	 E x 4
 ⑤ x 2	 ⑭ x 1	 ㉓ x 2	 F x 12
 ⑥ x 1	 ⑮ x 1	 ㉔ x 3	 G x 4
 ⑦ x 1	 ⑯ x 4	 ㉕ x 1	 H x 1
 ⑧ x 1	 ⑰ x 1	 ㉖ x 1	 I x 2
 ⑨ x 1	 ⑱ x 2	 A x 18	 J x 8
		 ⑱ x 1	 B x 33
		 ⑳ x 1	 C x 7
		 ㉑ x 1	 D x 2
		 ㉒ x 1	 E x 4
		 ㉓ x 2	 F x 12
		 ㉔ x 3	 G x 4
		 ㉕ x 1	 H x 1
		 ㉖ x 1	 I x 2
		 A x 18	 J x 8

2.5MDF

M5*50

M6*30

M6*25

M6*10

M4*14

M4*6

M4*18

M6*38

A x 8

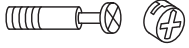

M6*38

H x 1



M4*18

A x 2

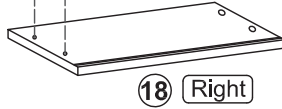

Right

A x 2

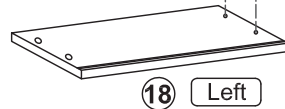

Left

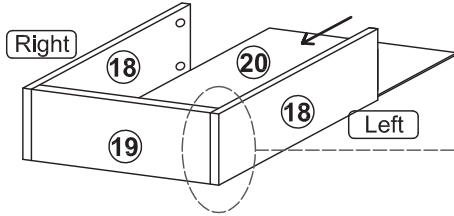

Right

Left

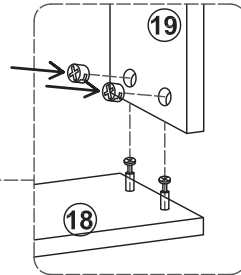

19

18

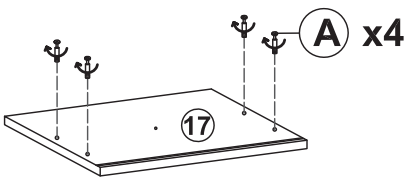

A x 4

17

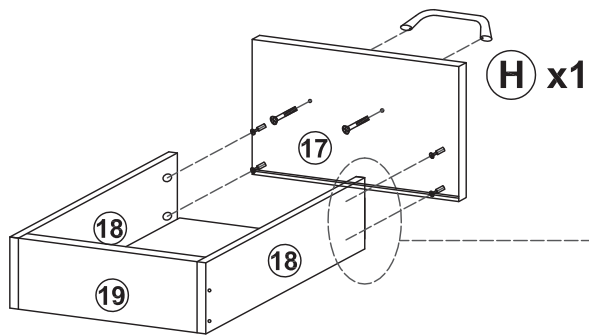

H x 1

17

19

18

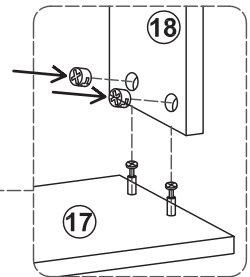

18

17

Pezzo "a" in plastica nera

Parte superiore

Premere verso il basso

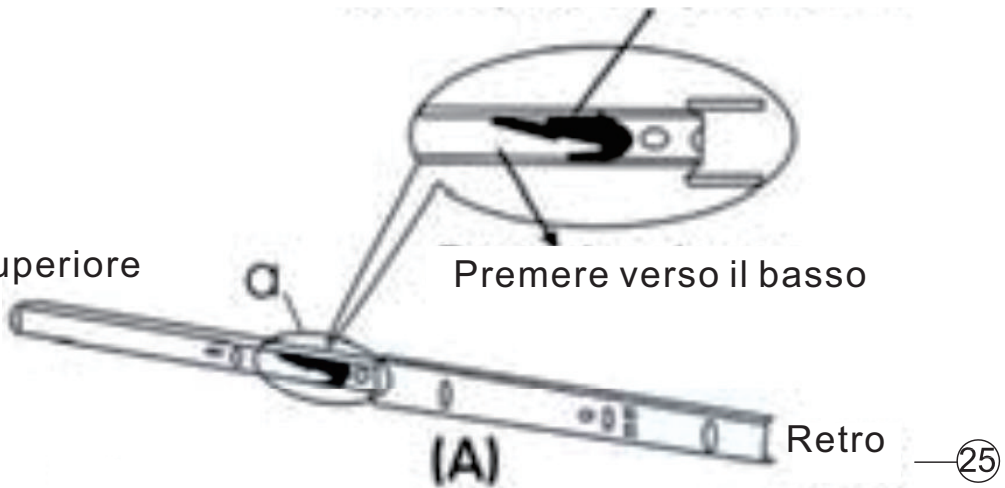

(A)

Retro

25

Retro

Premere "a" ed estrarre

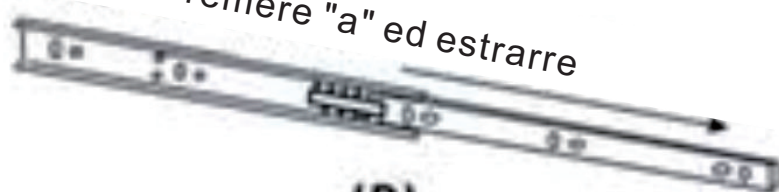

(B)

Parte superiore

F x 8



M4*14

J x 4

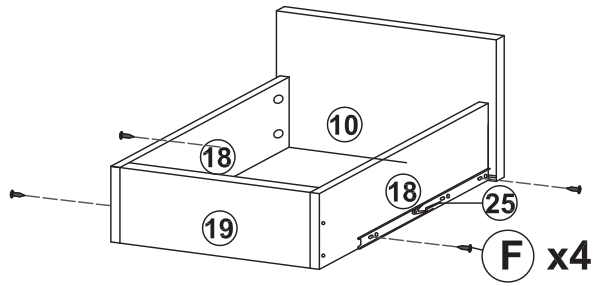
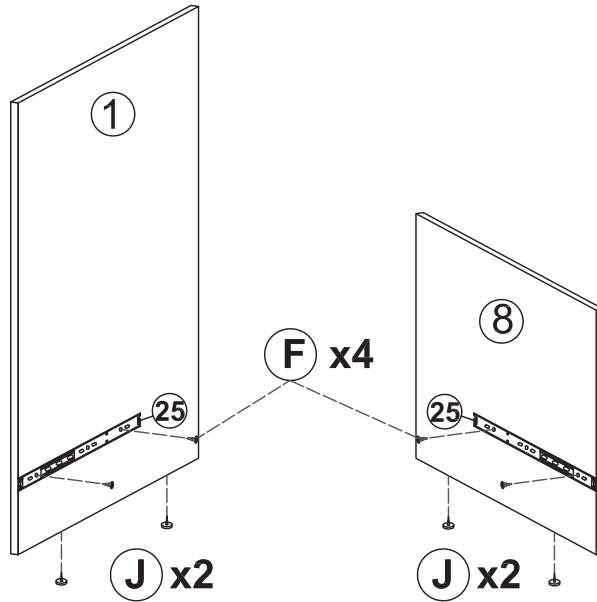

C x 2

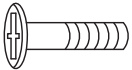

M6*30

J x 4

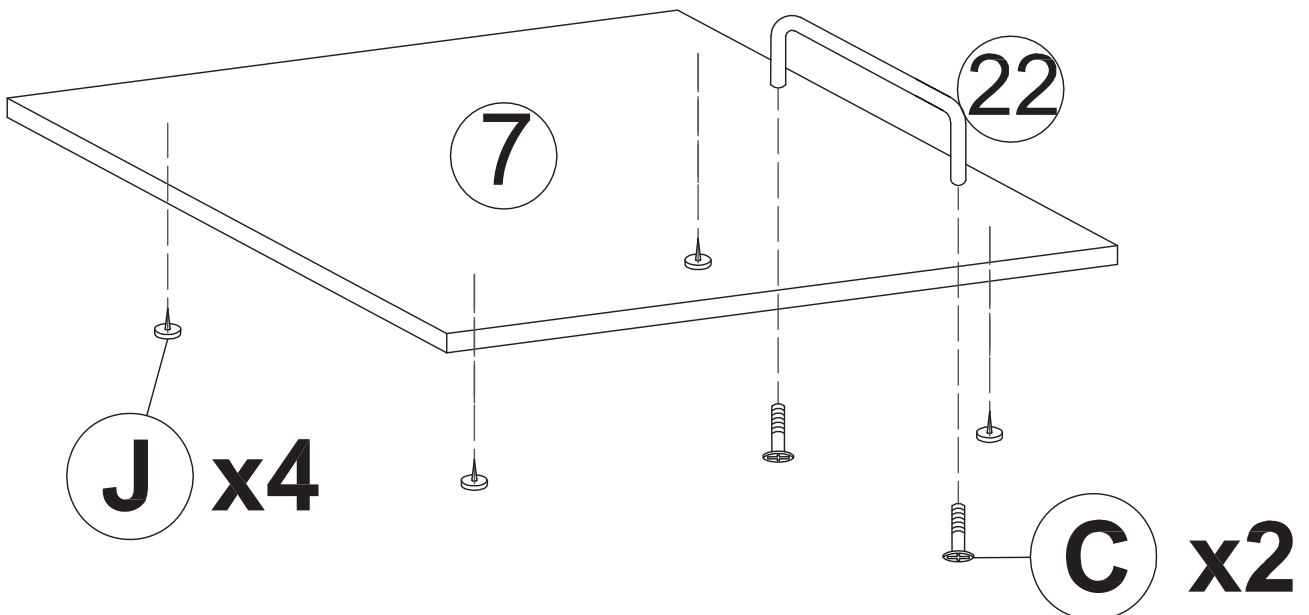

B x 6

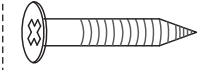

M5*50

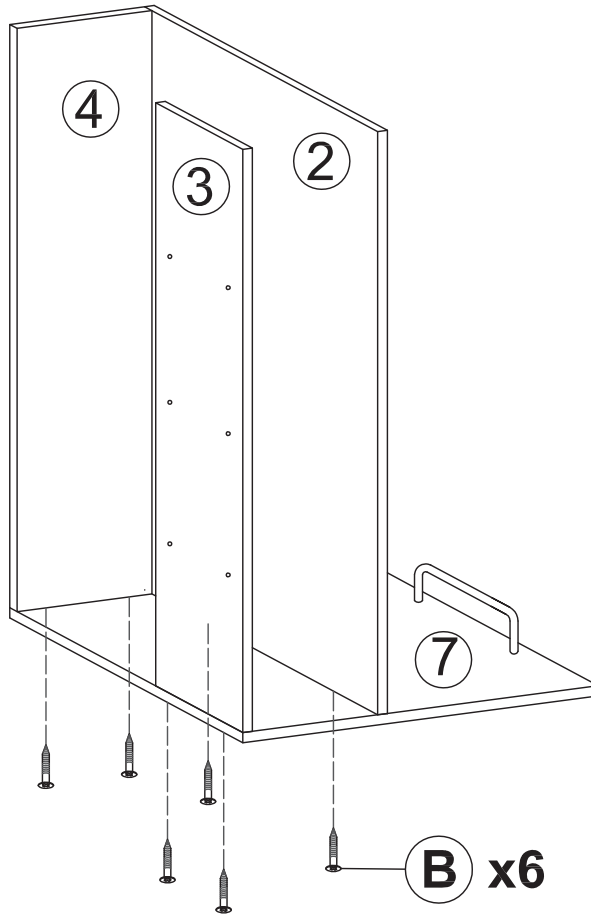

B x 13

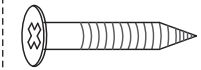

M5*50

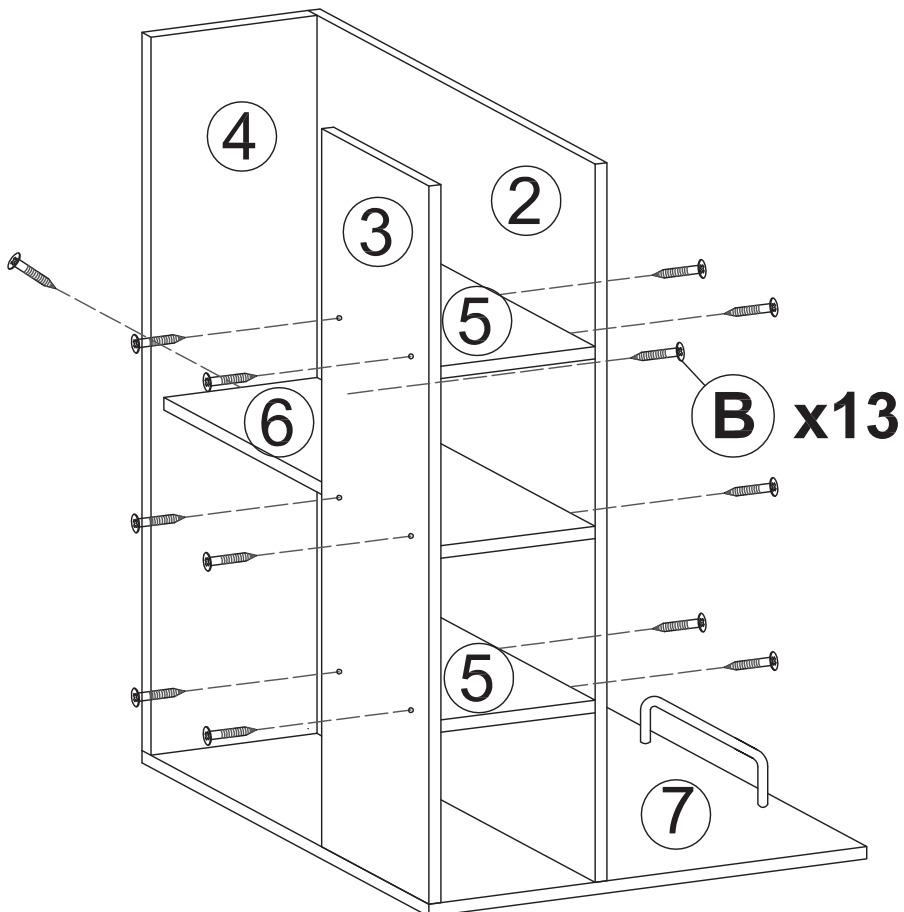

B x 6

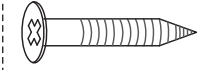

M5*50

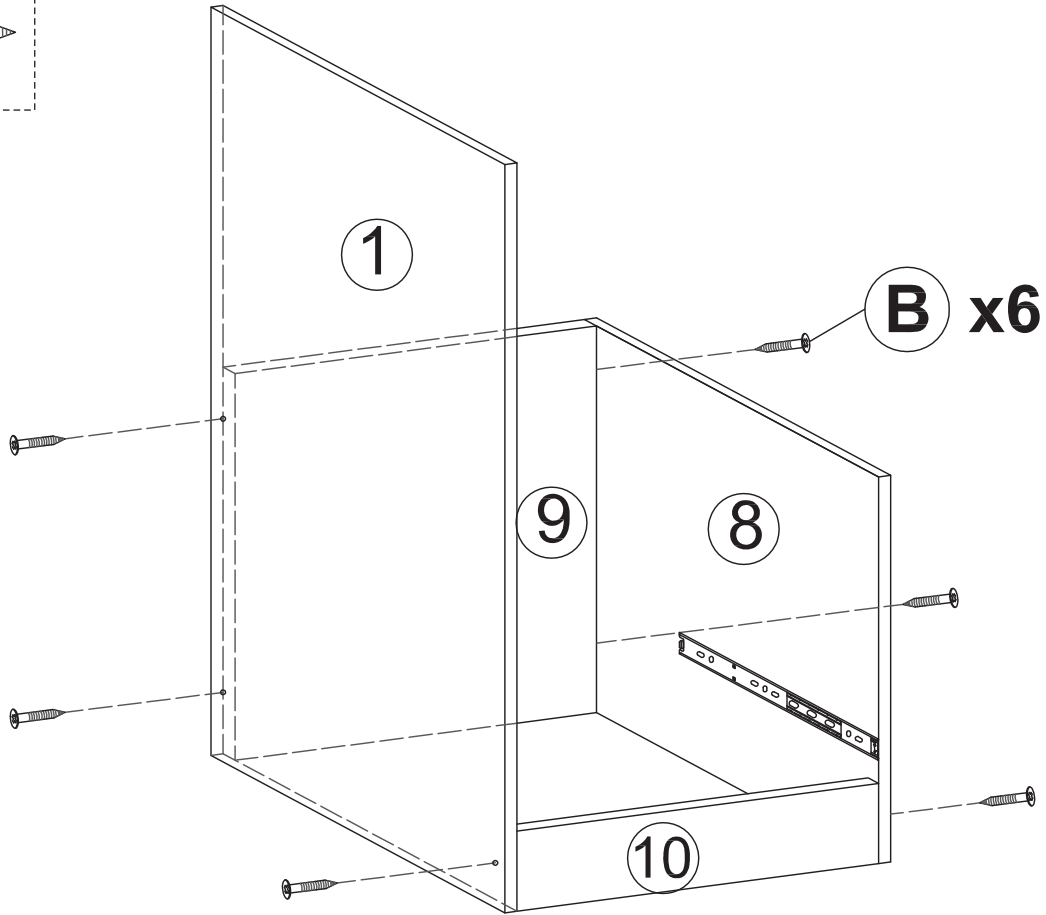

A x 2

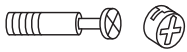

M6*38

B x 2

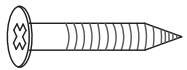

M5*50

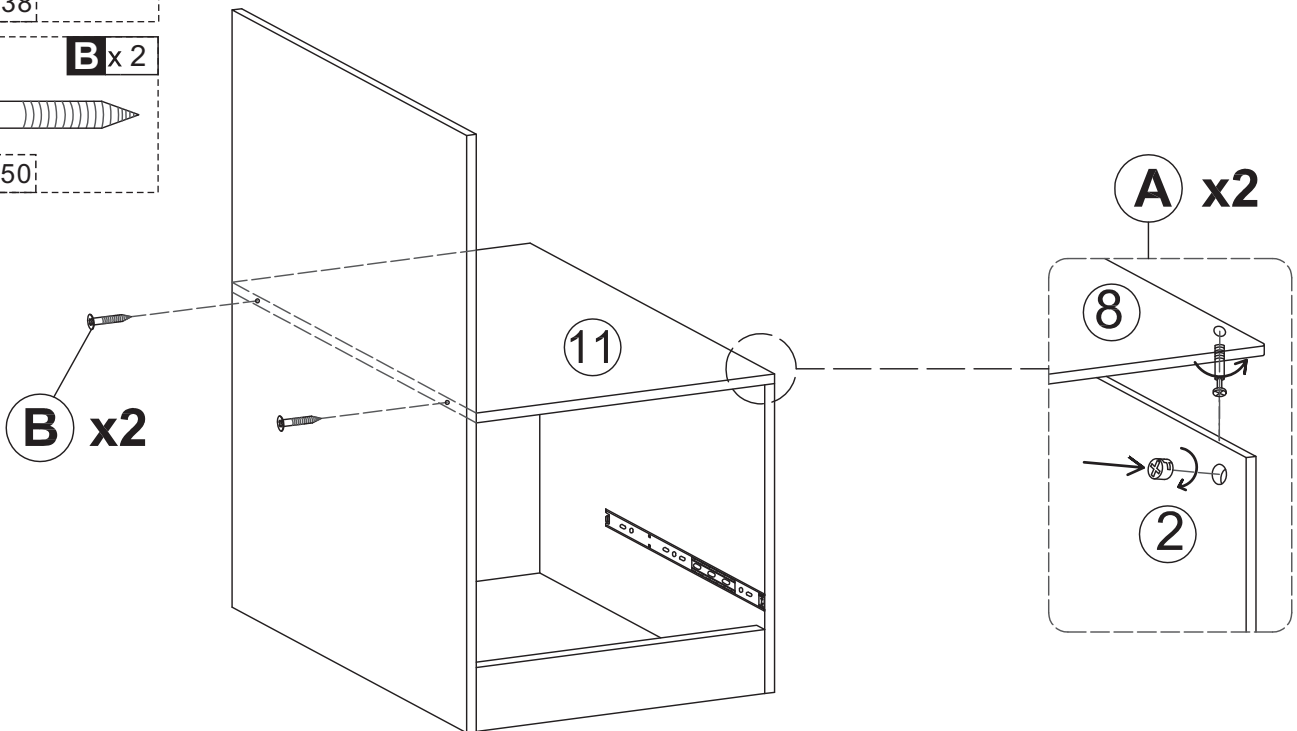

B x 2

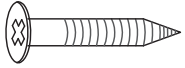

M5*50

C x 2

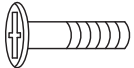

M6*30

D x 2

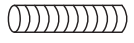

M6*25

I x 2



B x 2

D x 2

12

11

23

I x 2

C x 2

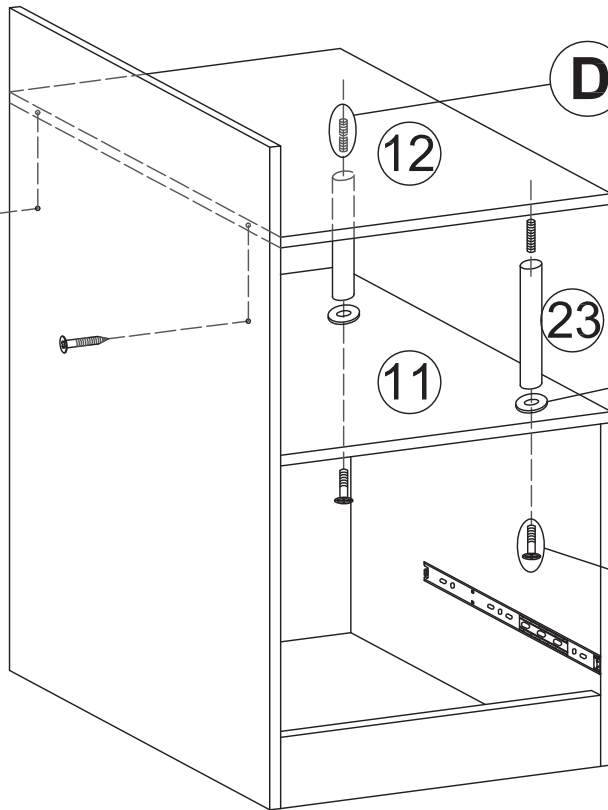

B x 4

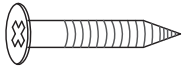

M5*50

B x 4

13

2

1

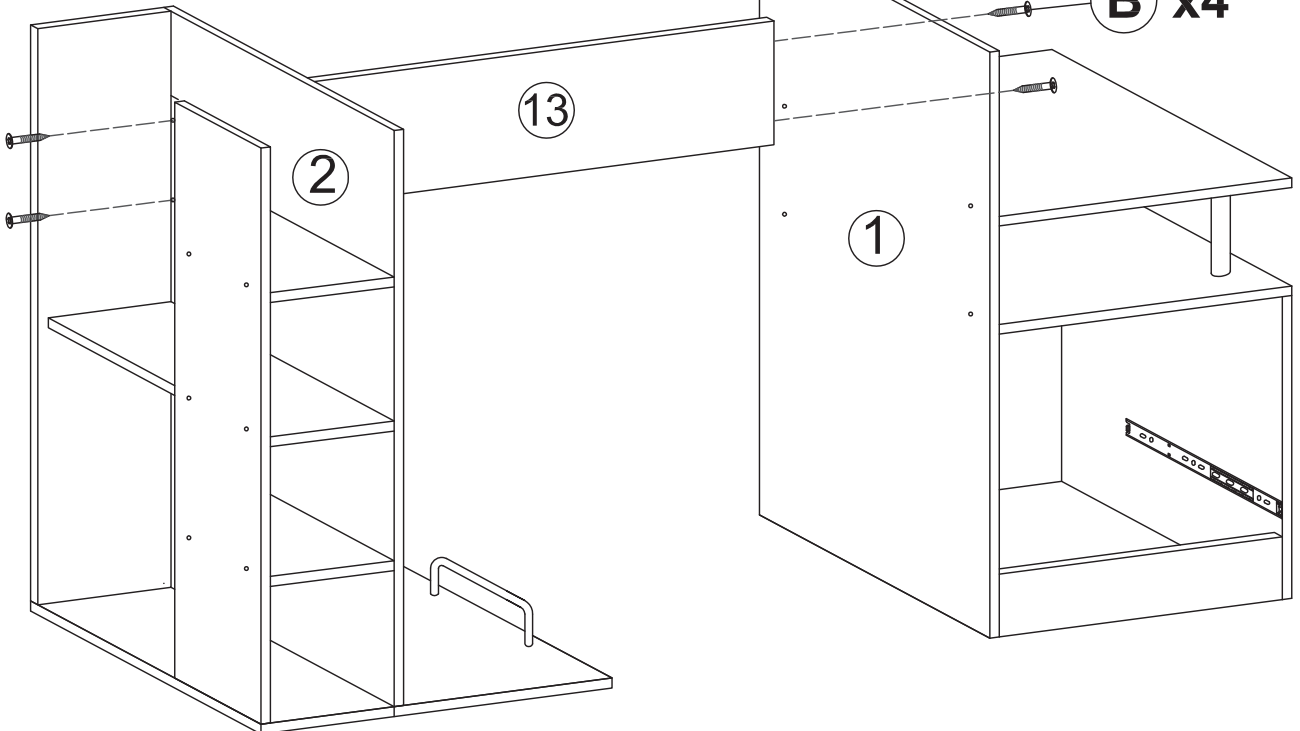

A x 8

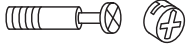

M6*38

E x 4



M6*10

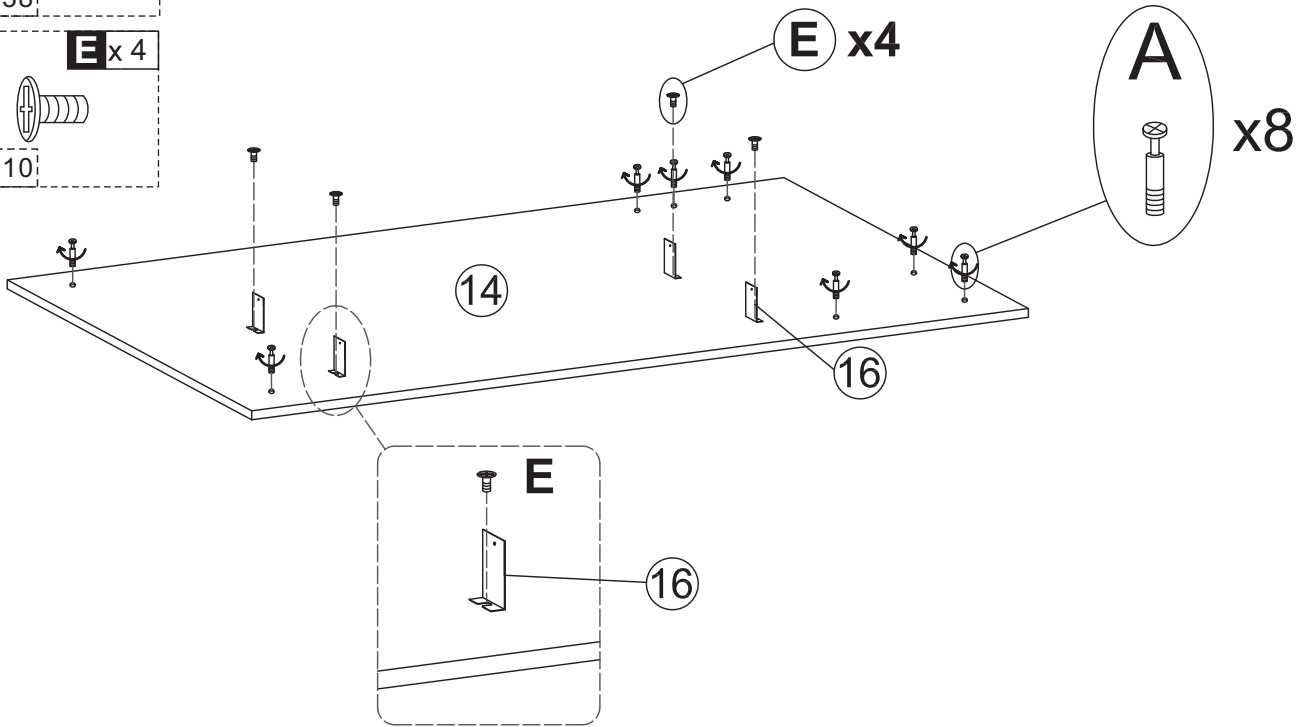

A x 8

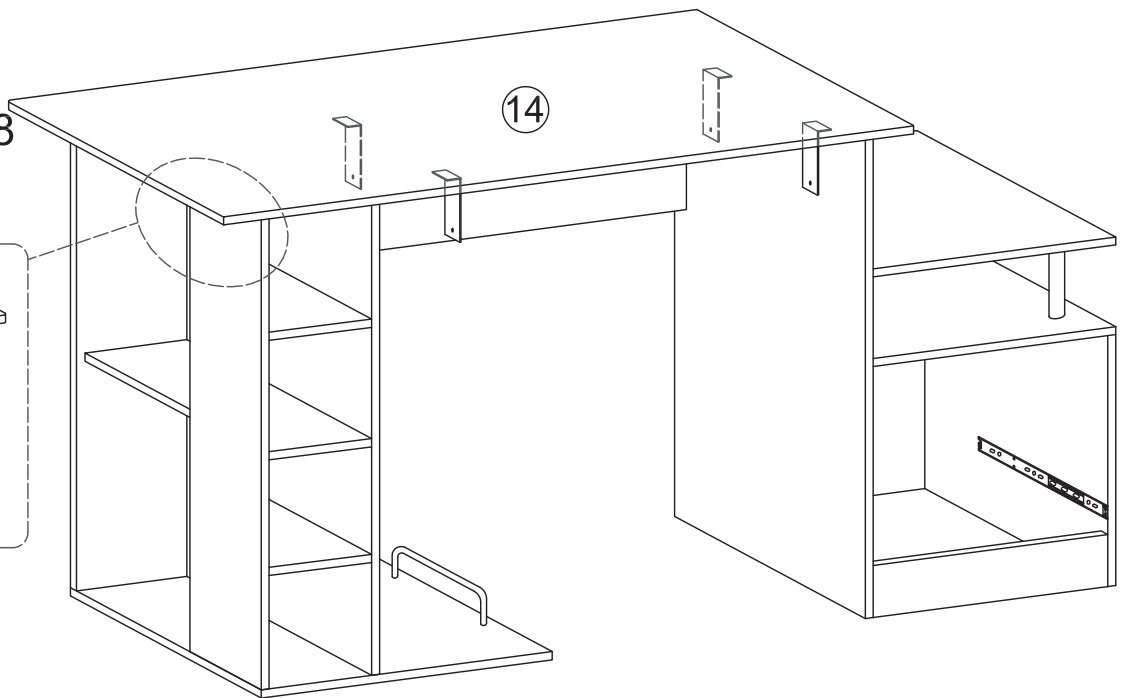
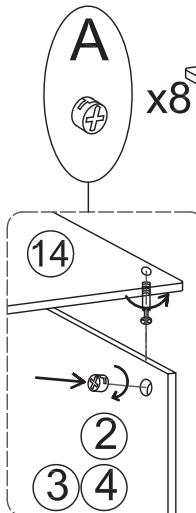

G x 4



M4*6

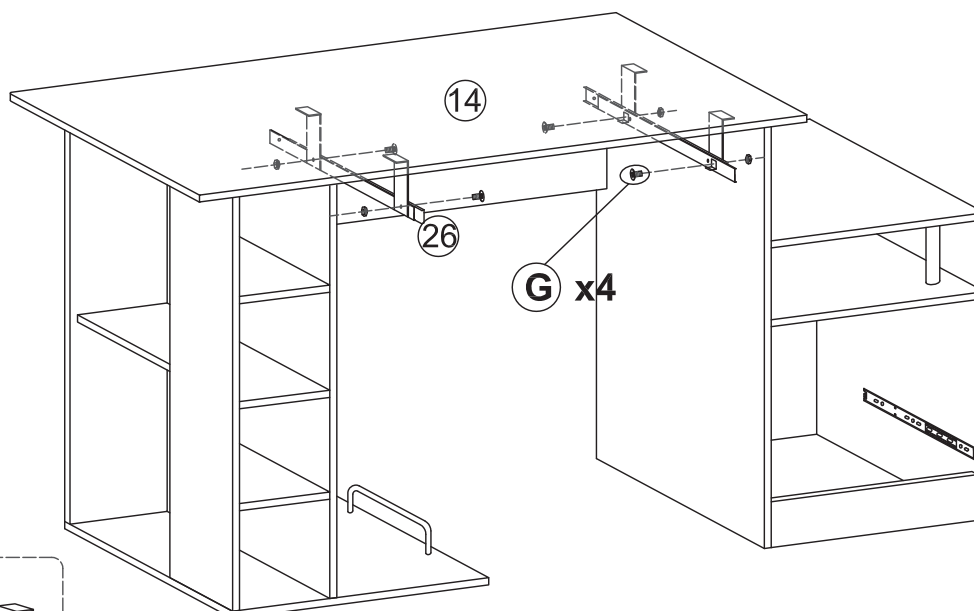

Right

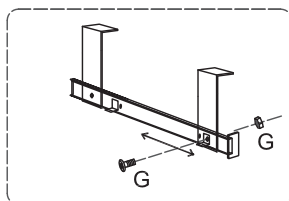
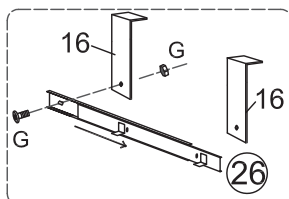

1. Aprire una parte di 26 e attaccarne il retro alla parte 16 tramite la parte G.

2. Allineare il foro della vite anteriore con il foro della vite sulla parte 16, poi fissare la parte anteriore del cursore.

3. Ripetere per collegare il cursore sinistro alla parte 16.

C x 3

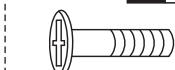

M6*30

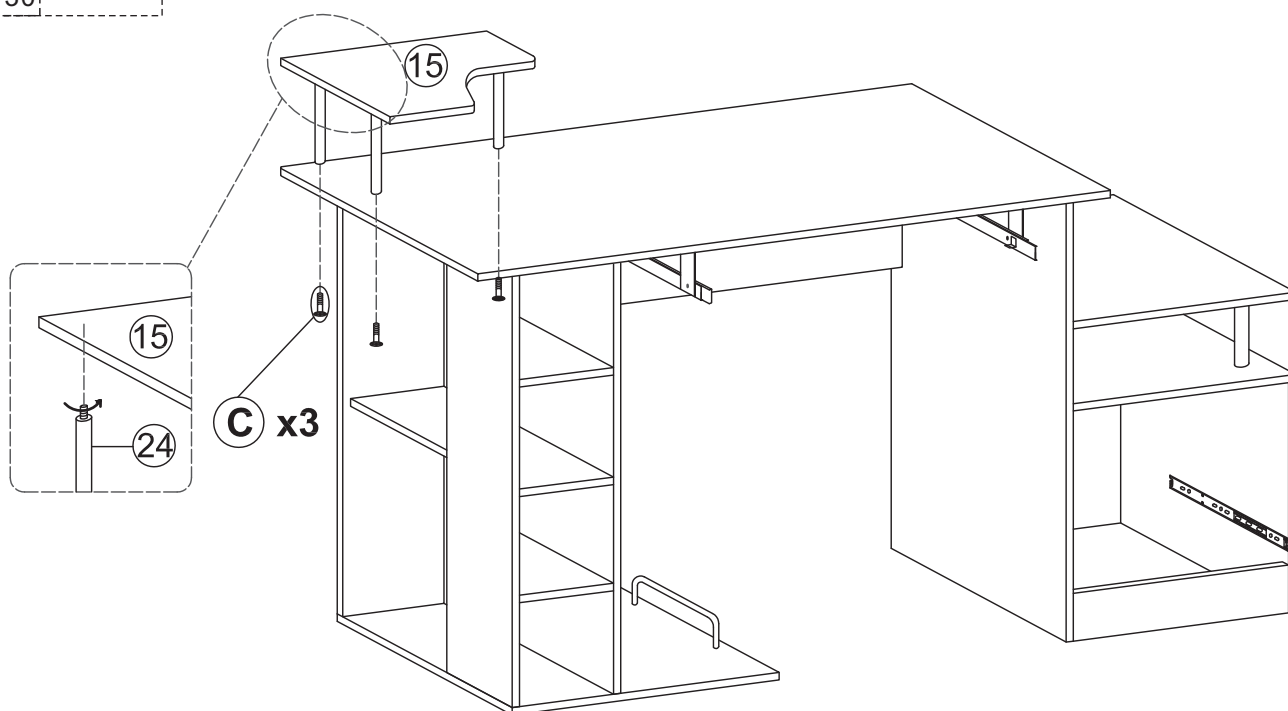

C x 3

F x 4



M4*14

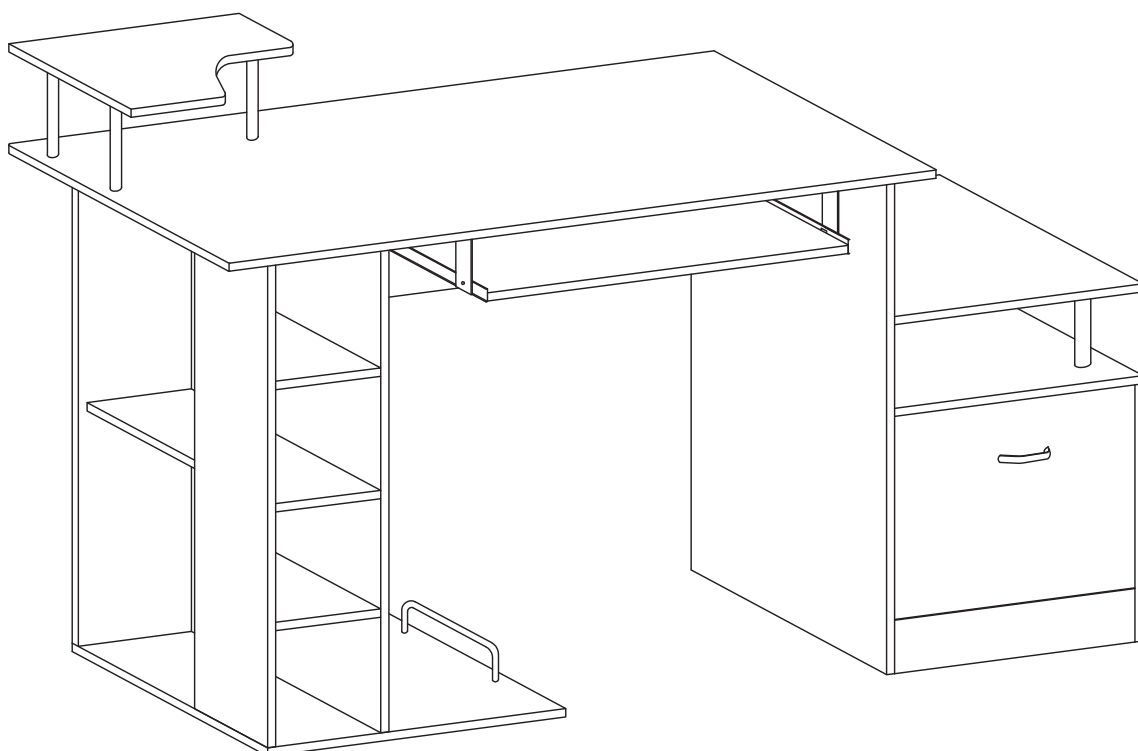
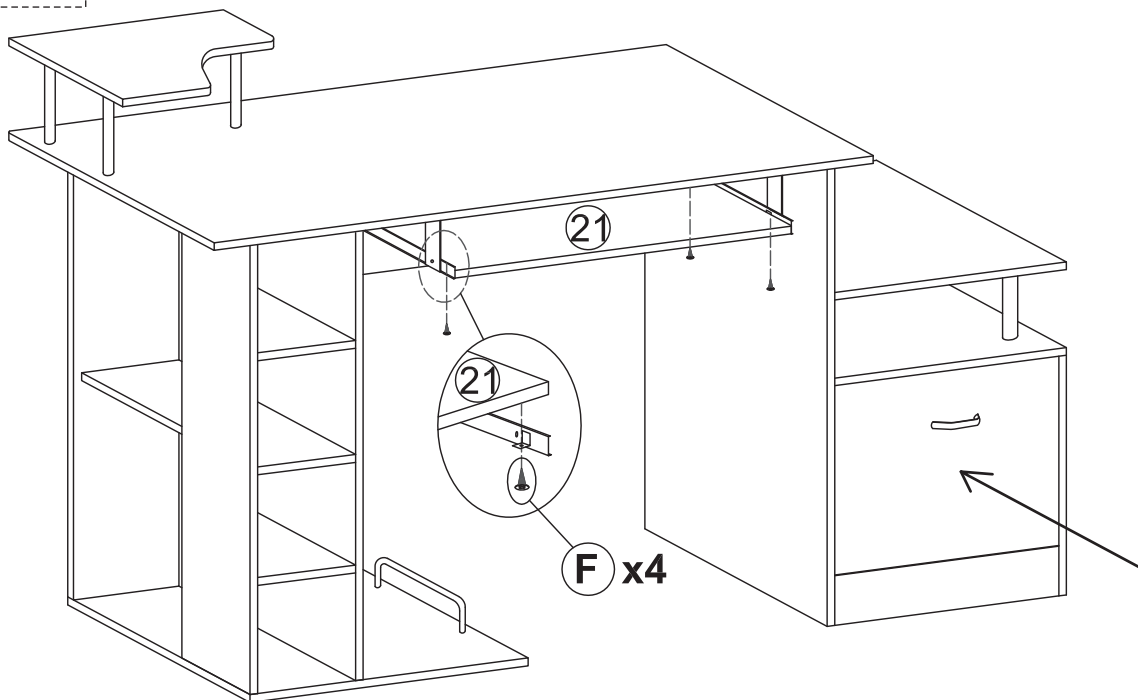

US



001-877-644-9366
customerservice@aosom.com

CA



001-855-537-6088
customerservice@aosom.ca

UK



0044-800-240-4004
enquiries@mhstar.co.uk

DE



0049-(0)40-88307530
service@aosom.de

FR



0033-1-84166106
contact@aosom.fr

ES



0034-931294512
atencioncliente@aosom.es

IT



0039-0249471447
clienti@aosom.it