

EN: **WARNING:** Suitable for children of 3-12 years old; Max weight: 30 kg.

DE: **WARNUNG:** Geeignet für Kinder im Alter von 3-12 Jahren; Max. Gewicht: 30 kg.

FR: **ATTENTION:** Convient aux enfants de 3 à 12 ans; Poids maximum : 30 kg.

ES: **ADVERTENCIA:** Adecuado para los niños de 3 a 12 años; Peso máximo: 30 kg.

IT: **ATTENZIONE:** Adatto a bambini di 3-12 anni; Peso massimo: 30 kg.

EN_IMPORTANT, RETAIN FOR FUTURE REFERENCE: READ CAREFULLY.

FR_IMPORTANT: A LIRE ATTENTIVEMENT ET À CONSERVER POUR CONSULTATION ULTÉRIEURE.

ES_IMPORTANTE, LEA Y GUARDE PARA FUTURAS REFERENCIAS.

DE_WICHTIG! SORGFÄLTIG LESEN UND FÜR SPÄTER NACHSCHLAGEN AUFBEWAHREN.

IT_IMPORTANTE! CONSERVARE IL PRESENTE MANUALE PER FUTURO RIFERIMENTO E LEGGERLO ATTENTAMENTE.

EN

Dear customer,

Thank you for purchasing this product. So that your appliance serves you well, please read all the instructions in this user's manual. If you have any questions, please contact our customer care center.

FR

Cher client,

Nous vous remercions d'avoir acheté ce produit. Afin que vous puissiez profiter pleinement de votre appareil, veuillez lire toutes les instructions de ce manuel d'utilisation. Si vous avez la moindre question, veuillez contacter notre centre d'assistance à la clientèle.

DE

Sehr geehrter Kunde,

Vielen Dank, dass Sie dieses Produkt erworben haben. Damit Ihr Gerät Ihnen gute Dienste leistet, lesen Sie bitte alle Hinweise in diesem Benutzerhandbuch. Wenn Sie Fragen haben, wenden Sie sich bitte an unser Kundendienstzentrum.

ES

Queridos clientes,

Gracias por comprar este producto. Para que su electrodoméstico le sirva mejor, lea todas las instrucciones de este manual del usuario. Si tiene alguna pregunta, comuníquese con nuestro Centro de Atención al Cliente.

PT

Caros clientes,

Obrigado por adquirir este produto. Para que o seu aparelho o sirva melhor, leia todas as instruções deste manual do utilizador. Se tiver alguma dúvida, por favor contacte o nosso Centro de Atendimento ao Cliente.

IT

Caro Cliente,

Grazie per aver acquistato questo prodotto. Per servirti meglio con questo apparecchio ti prego di leggere tutte le istruzioni in presente manuale utente. In caso di dubbio, si prega di contattare il nostro centro assistenza clienti.

EN_Our contact details are below:



FR_Nos coordonnées sont les suivantes:

DE_Unsere Kontaktdaten stehen unten:

ES_Nuestros datos de contacto son los siguientes:

PT_Os nossos dados de contacto são os seguintes:

IT_I nostri dettagli di contatto sono di seguito:

| Country |  Phone |  Email |
|---------|---|---|
| UK | 0044-800-240-4004 | enquiries@mhstar.co.uk |
| DE | 0049-0(40)-88307530 | service@aosom.de |
| FR | 0033-1-84166106 | aosom@mhfrance.fr |
| ES&PT | 0034-931294512 | atencioncliente@aosom.es |
| IT | 0039-0249471447 | clienti@aosom.it |

EN

WARNING:

1. CHOKING HAZARD—Small parts. Not for children under 3 years.
2. Only allowed for adults to install, keep children away.
3. To be used under the direct supervision of an adult.
4. Place it on a flat and clean floor, Check all the parts are well connected before use.

MAINTENANCE & CARE

- A. Keep all instructions and parts relating to this product for future reference.
- B. Please wipe down with a dry or damp cloth.

FR

AVERTISSEMENT :

1. RISQUE D'ÉTOUFFEMENT - Petites pièces. Déconseillé aux enfants de moins de 3 ans.
2. Installation par des adultes uniquement, tenir les enfants à l'écart.
3. À utiliser sous la surveillance directe d'un adulte.
4. Posez-le sur un sol plat et propre. Vérifiez que toutes les pièces sont bien connectées avant toute utilisation.

ENTRETIEN ET MAINTENANCE

- A. Conservez toutes les instructions et les pièces relatives à ce produit pour pouvoir vous y référer ultérieurement.
- B. Veuillez essuyer avec un chiffon sec ou humide.



FR

**Pensez à
donner ou recycler.**



Association

ou



Magasin

ou



Déchèterie

<https://quefairedemesdechets.fr>

DE

WARNUNG:

1. ERSTICKUNGSGEFAHR-Kleine Teile. Nicht für Kinder unter 3 Jahren geeignet.
2. Die Montage darf nur von Erwachsenen vorgenommen werden, halten Sie Kinder fern.
3. Es ist unter der direkten Aufsicht eines Erwachsenen zu verwenden.
4. Stellen Sie es auf einen flachen und sauberen Boden. Prüfen Sie, ob alle Teile vor der Verwendung gut verbunden sind.

WARTUNG & PFLEGE

- A. Bewahren Sie alle Anweisungen und Teile, die sich auf dieses Produkt beziehen, zur späteren Verwendung auf.
- B. Bitte wischen Sie es mit einem trockenen oder feuchten Tuch ab.

ES

ADVERTENCIA:

1. PELIGRO DE ASFIXIA: Incluidas piezas pequeñas. No es adecuado para los niños menores de 3 años.
2. La instalación sólo se puede realizar por los adultos, mantenga a los niños alejados al instalar el producto.
3. El producto debe ser utilizado bajo la supervisión directa de un adulto.
4. Colóquelo sobre un piso plano y limpio. Verifique si todas las piezas estén conectadas adecuadamente antes de utilizarlo.

MANTENIMIENTO Y CUIDADO

- A. Guarde todas las instrucciones y piezas relativas juntas con este producto para las referencias futuras.
- B. Límpielo con un paño seco o humedecido.

IT

AVVERTENZE:

1. RISCHIO DI SOFFOCAMENTO — Parti piccole. Non adatte a bambini sotto i 3 anni.
2. Consentito solo agli adulti di installare, tenere lontani i bambini.
3. Da utilizzare sotto la diretta supervisione di un adulto.
4. Posizionarlo su una superficie piana e pulita, controllare che tutte le parti siano connesse correttamente prima dell'uso.

MANUTENZIONE & CURA

- A. Conservare tutte le istruzioni e le parti relative a questo prodotto per riferimenti futuri.
- B. Si prega di pulire passando un panno asciutto o inumidito.

PARTS

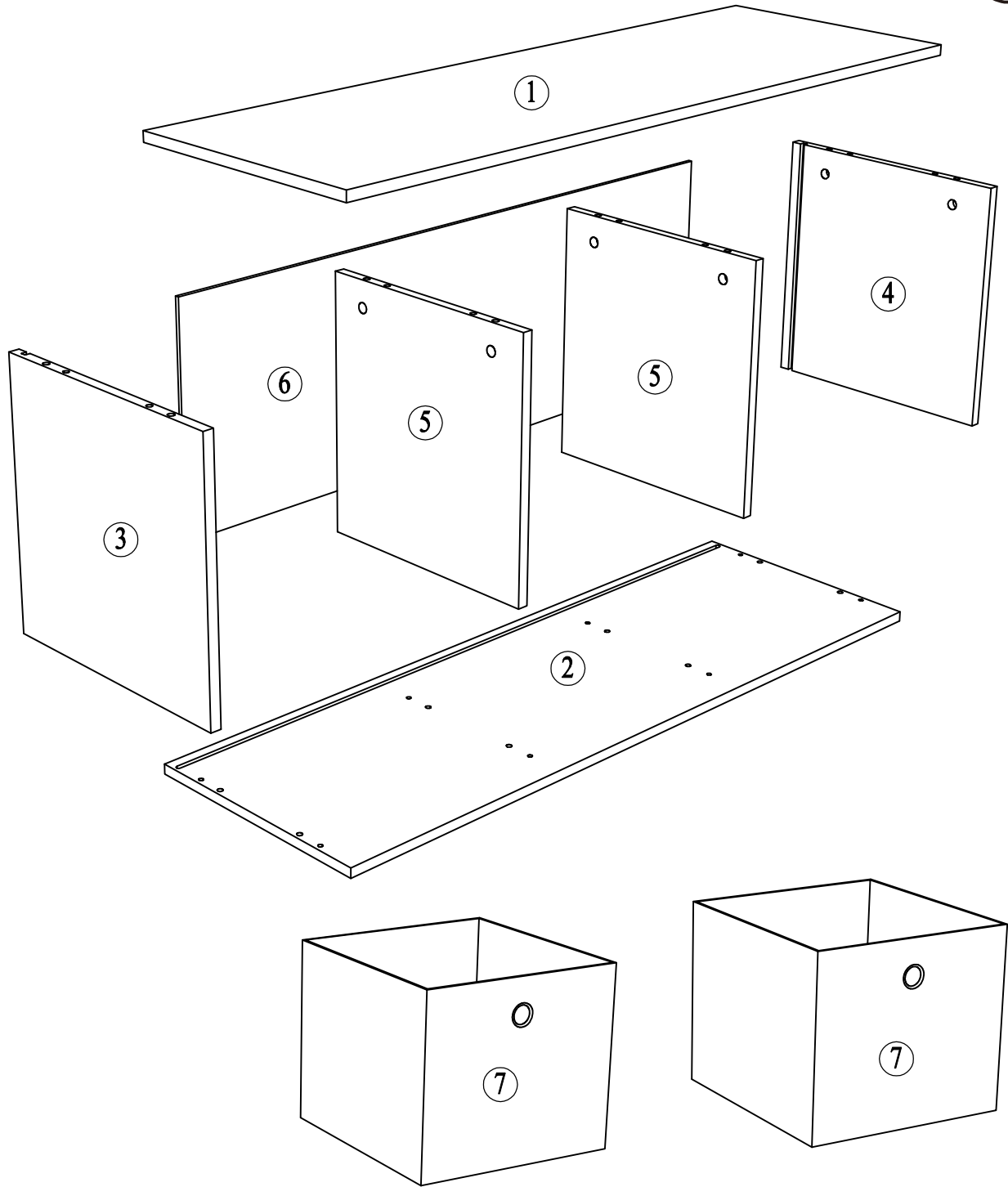

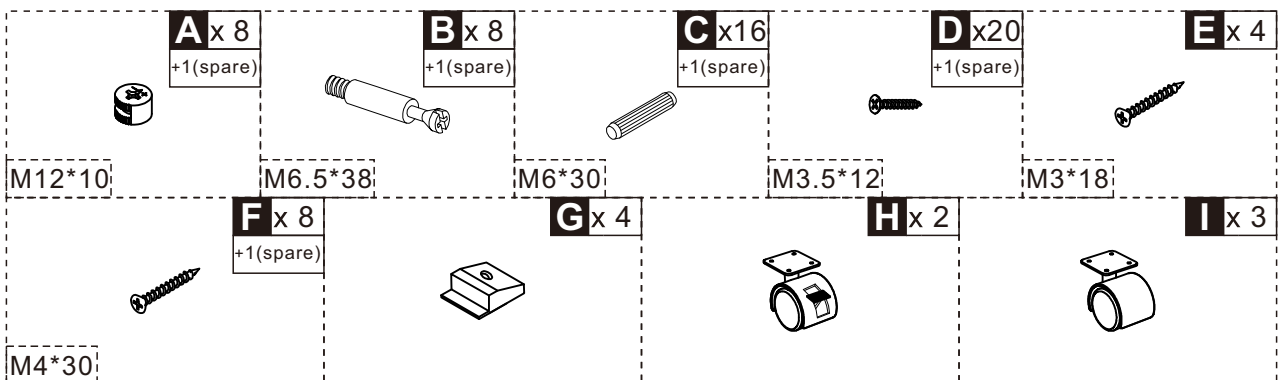

HARDWARE

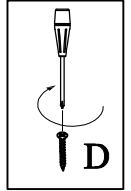
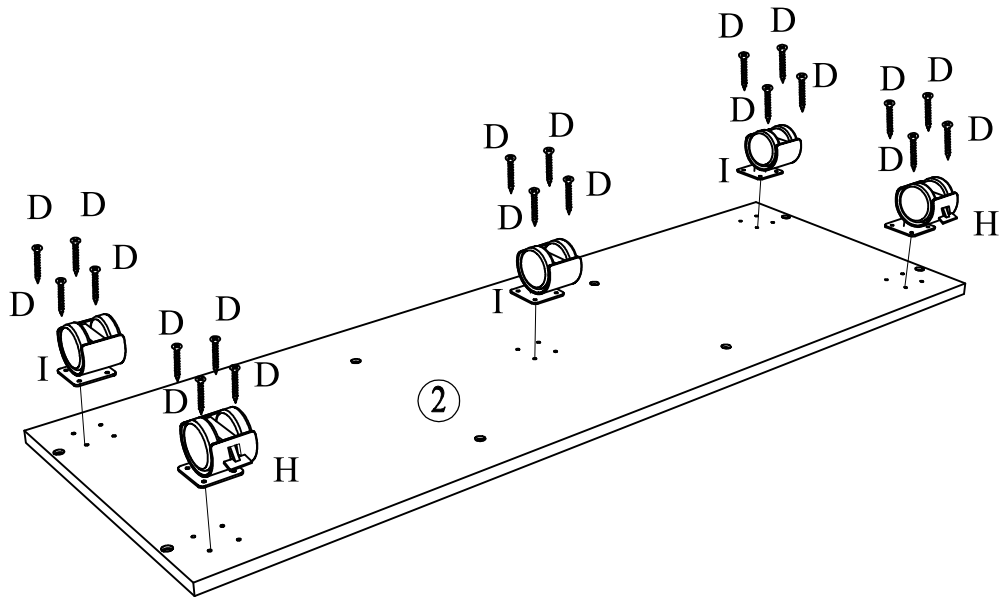

1



| | | |
|---|---|--|
| I  x3 | H  x2 | D  M3.5x 12mm x20 |
|---|---|--|

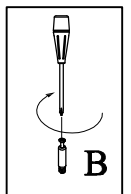
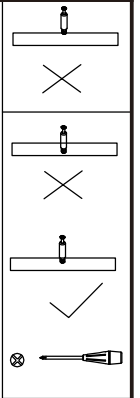
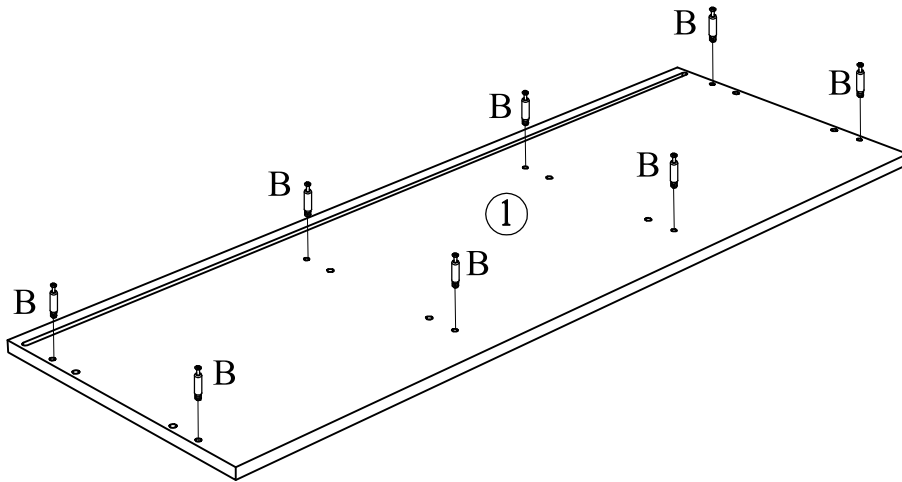

2

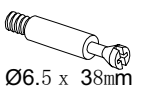

| |
|--|
| B  Ø6.5 x 38mm x8 |
|--|

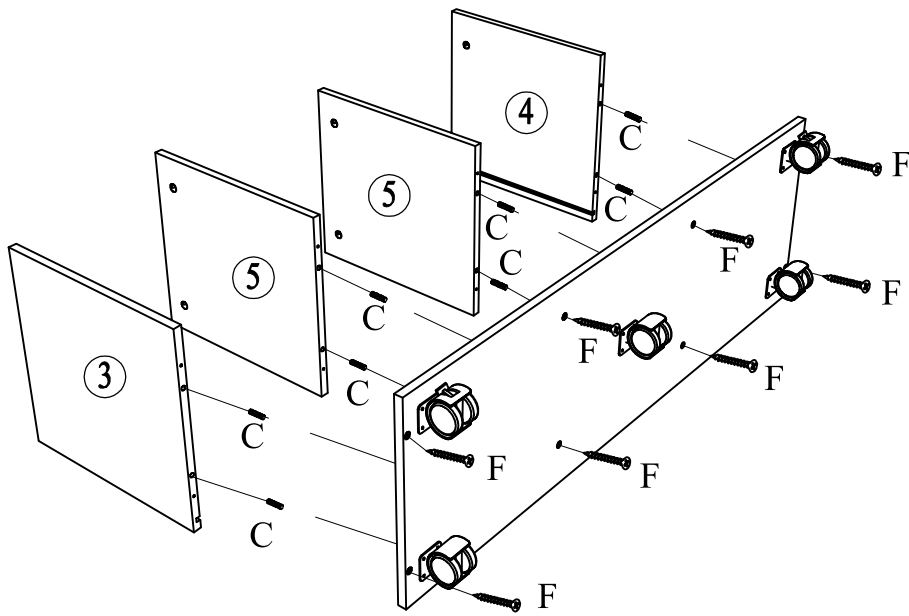
3



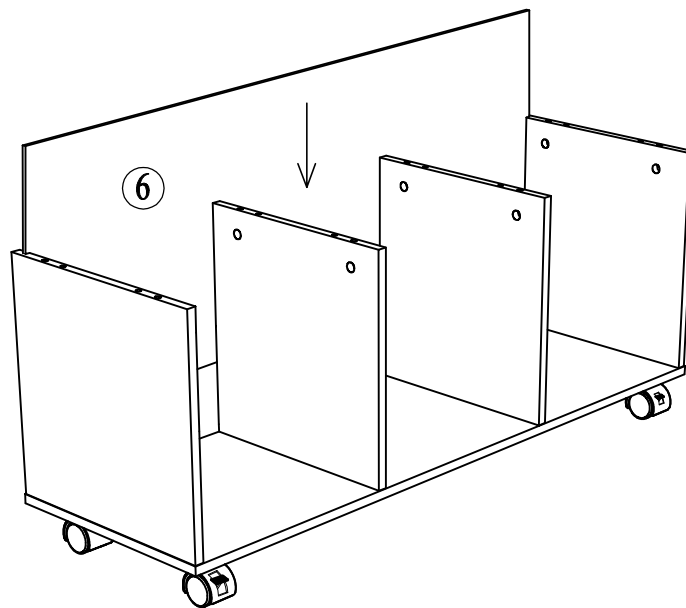

| | |
|--|---|
| F  M4x 30mm x8 | C  Ø6 x 30mm x8 |
|--|---|

4



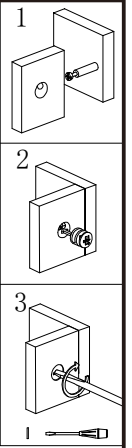
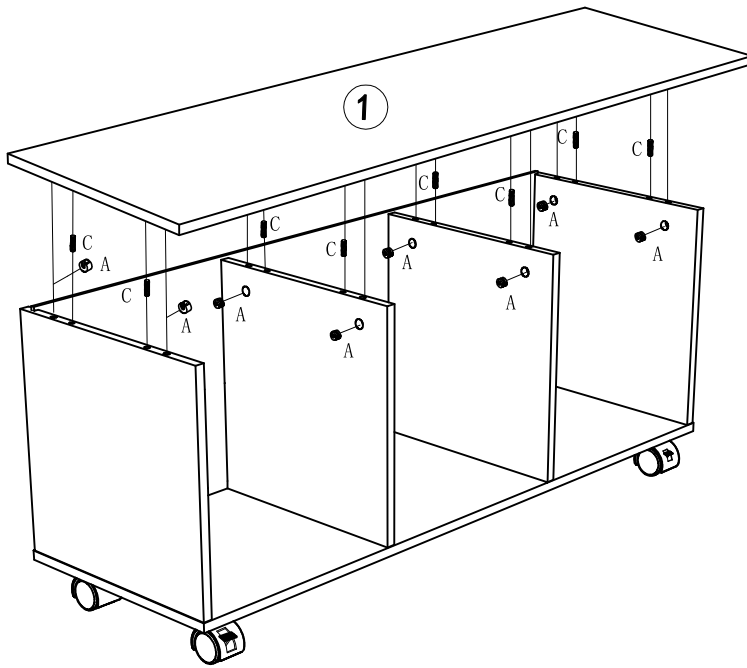

5

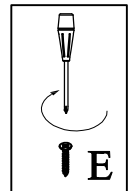
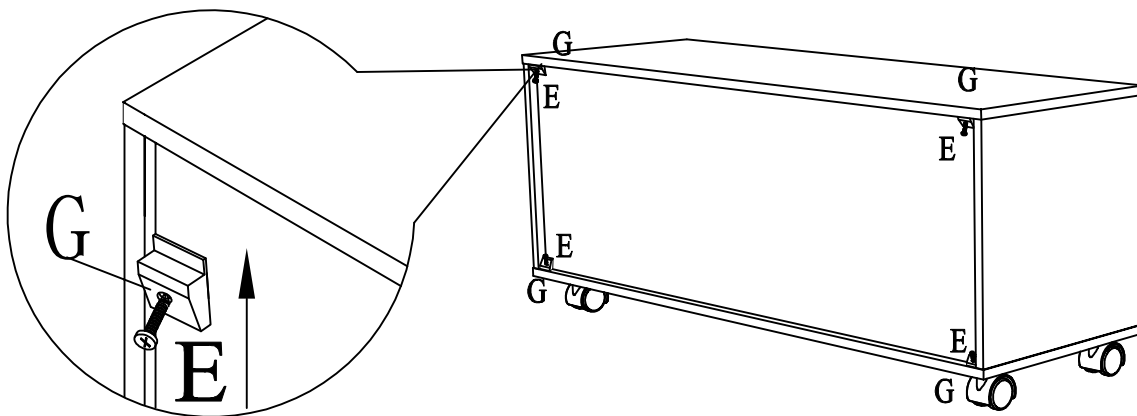

| | |
|---|---|
| <p>C</p>  <p>Ø6 x 30mm</p> <p>x8</p> | <p>A</p>  <p>Ø12x10mm</p> <p>x 8</p> |
|---|---|

6



| | |
|---|---|
| <p>G</p>  <p>x4</p> | <p>E</p>  <p>M3x 16mm</p> <p>x4</p> |
|---|---|

7

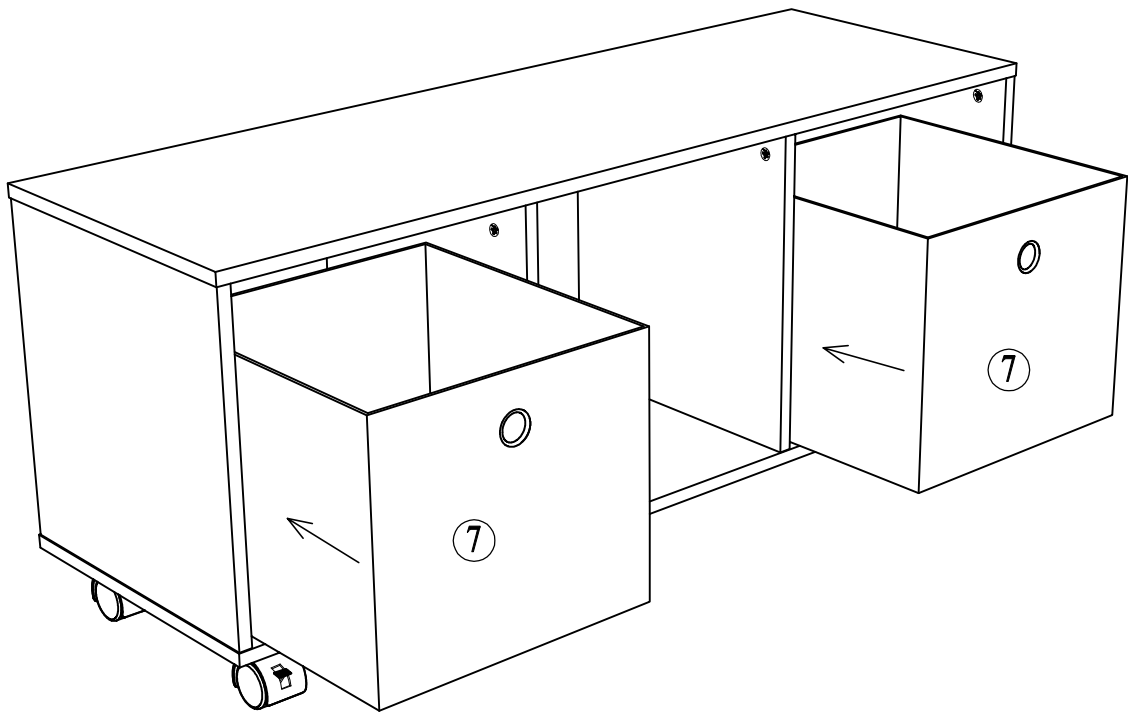

| Carton | Reference No. | Quantity |
|---------------|----------------------|-----------------|
| 1/1 | 1 | 1 |
| 1/1 | 2 | 1 |
| 1/1 | 3 | 1 |
| 1/1 | 4 | 1 |
| 1/1 | 5 | 2 |
| 1/1 | 6 | 1 |
| 1/1 | 7 | 2 |
| 1/1 | Accessories | 1 |

IMPORTER

MH STAR UK LTD
Address: Unit 27, Perivale Park,
Horsenden lane South
Perivale, UB6 7RH
MADE IN CHINA

IMPORTATEUR

MH Handel GmbH
Wendenstraße 309
D-20537 Hamburg
Germany
IN CHINA HERGESTELLT

IMPORTEUR

MH FRANCE
2 Rue Maurice Hartmann
92130 Issy Les Moulineaux
France
FABRIQUÉ EN CHINE

IMPORTATO DA

AOSOM Italy srl
Centro Direzionale Milanofiori
Strada 1 Palazzo F1
20057 Assago (MI)
P.I.: 08567220960
FATTO IN CINA

IMPORTADOR POR

IMPORTADOR:
SPANISH AOSOM, S.L.
C/ ROC GROS, Nº 15. 08550, ELS HOSTALET DE BALENYÀ, SPAIN.
B66295775
WWW.AOSOM.ES
ATENCIONCLIENTE@AOSOM.ES
TEL: 931294512
HECHO EN CHINA

