

EN: **WARNING:** Suitable for children of 3-12 years old; Max weight: 30 kg.

FR: **ATTENTION:** Convient aux enfants de 3 à 12 ans; Poids maximum : 30 kg.

EN_IMPORTANT, RETAIN FOR FUTURE REFERENCE: READ CAREFULLY.

FR_IMPORTANT: A LIRE ATTENTIVEMENT ET À CONSERVER POUR CONSULTATION ULTÉRIEURE.

EN

Dear customer,

Thank you for purchasing this product. So that your appliance serves you well, please read all the instructions in this user's manual. If you have any questions, please contact our customer care center.



FR

Cher client,

Nous vous remercions d'avoir acheté ce produit. Afin que vous puissiez profiter pleinement de votre appareil, veuillez lire toutes les instructions de ce manuel d'utilisation. Si vous avez la moindre question, veuillez contacter notre centre d'assistance à la clientèle.

EN_Our contact details are below:

FR_Nos coordonnées sont les suivantes:

Country	 Phone	 Email
US	001-877-644-9366	customerservice@aosom.com
CA	416-792-6088	customerservice@aosom.ca

EN

WARNING:

1. CHOKING HAZARD—Small parts. Not for children under 3 years.
2. Only allowed for adults to install, keep children away.
3. To be used under the direct supervision of an adult.
4. Place it on a flat and clean floor, Check all the parts are well connected before use.

MAINTENANCE & CARE

- A. Keep all instructions and parts relating to this product for future reference.
- B. Please wipe down with a dry or damp cloth.

FR

AVERTISSEMENT :

1. RISQUE D'ÉTOUFFEMENT - Petites pièces. Déconseillé aux enfants de moins de 3 ans.
2. Installation par des adultes uniquement, tenir les enfants à l'écart.
3. À utiliser sous la surveillance directe d'un adulte.
4. Posez-le sur un sol plat et propre. Vérifiez que toutes les pièces sont bien connectées avant toute utilisation.

ENTRETIEN ET MAINTENANCE

- A. Conservez toutes les instructions et les pièces relatives à ce produit pour pouvoir vous y référer ultérieurement.
- B. Veuillez essuyer avec un chiffon sec ou humide.

PARTS

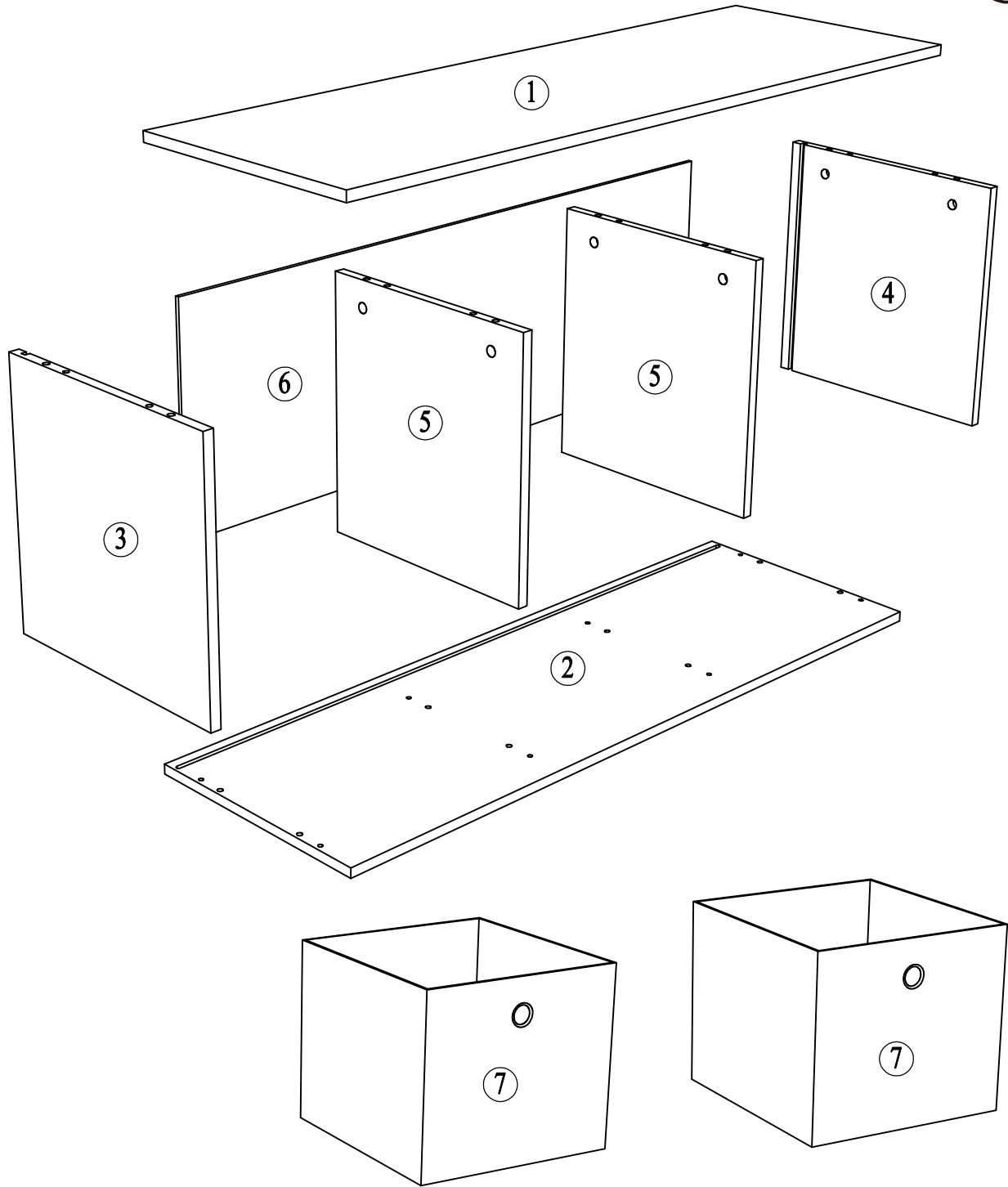

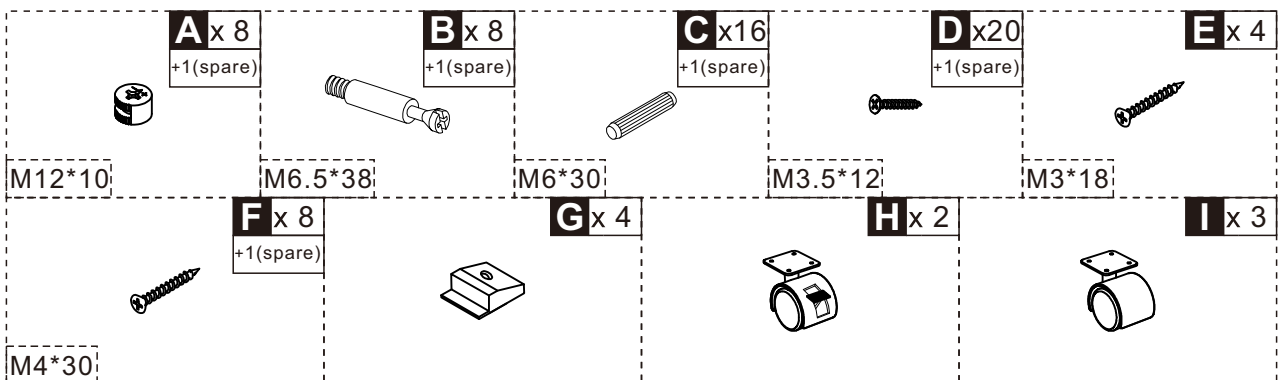

HARDWARE



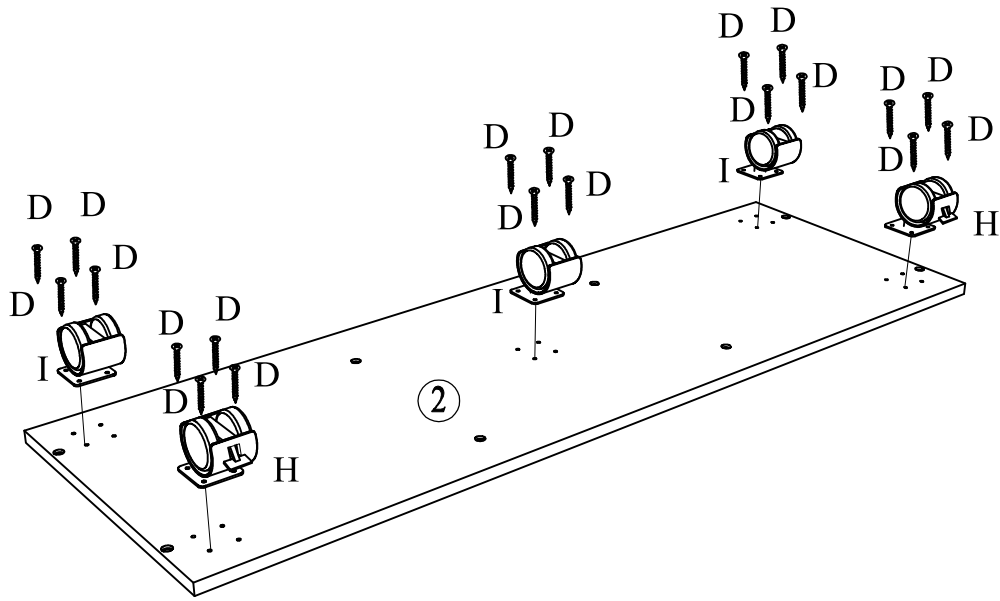

1



I  x3	H  x2	D  M3.5x 12mm x20
---	---	--

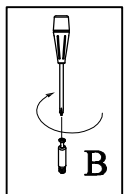
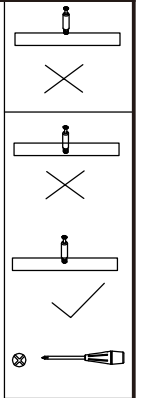
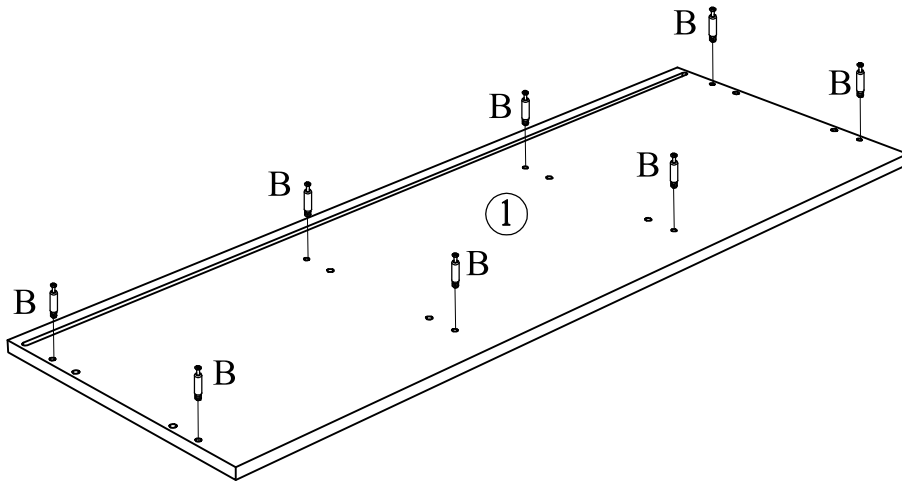

2

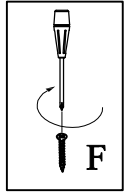
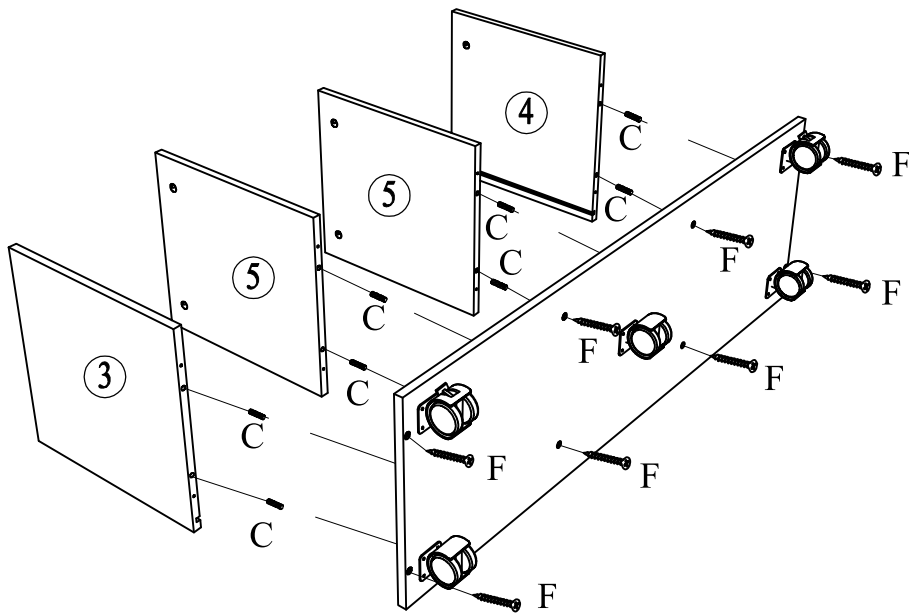

B  Ø6.5 x 38mm x8
--

3



F  M4x 30mm x8	C  Ø6 x 30mm x8
--	---

4

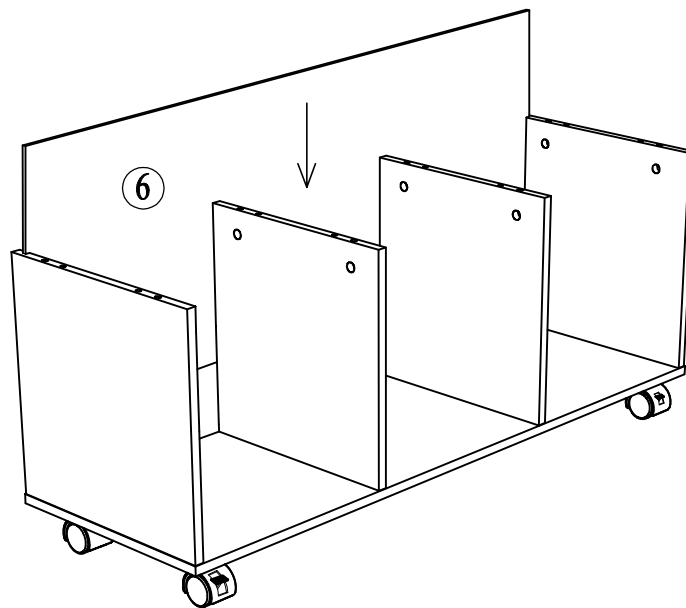

5

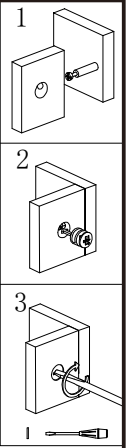
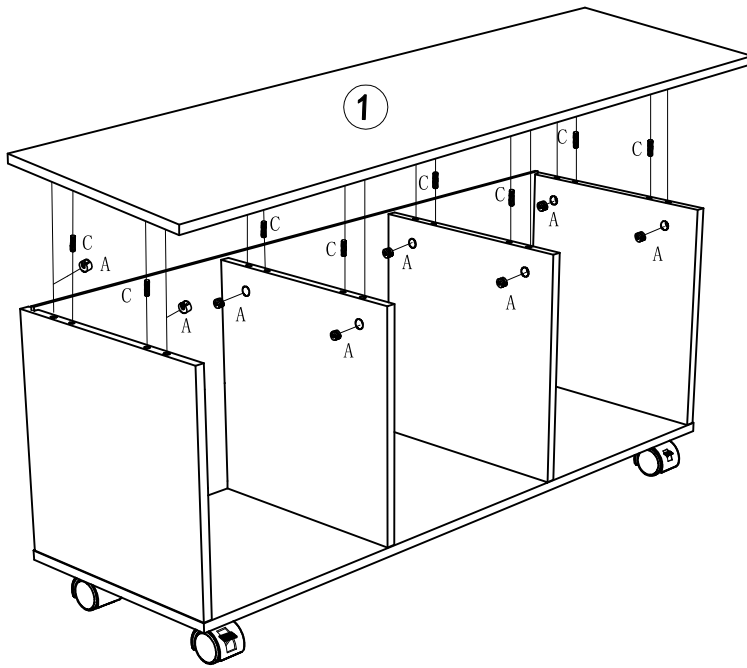

<p>C</p> <p>∅6 x 30mm x8</p>	<p>A</p> <p>∅12x10mm x 8</p>
---	---

6

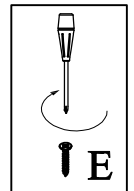
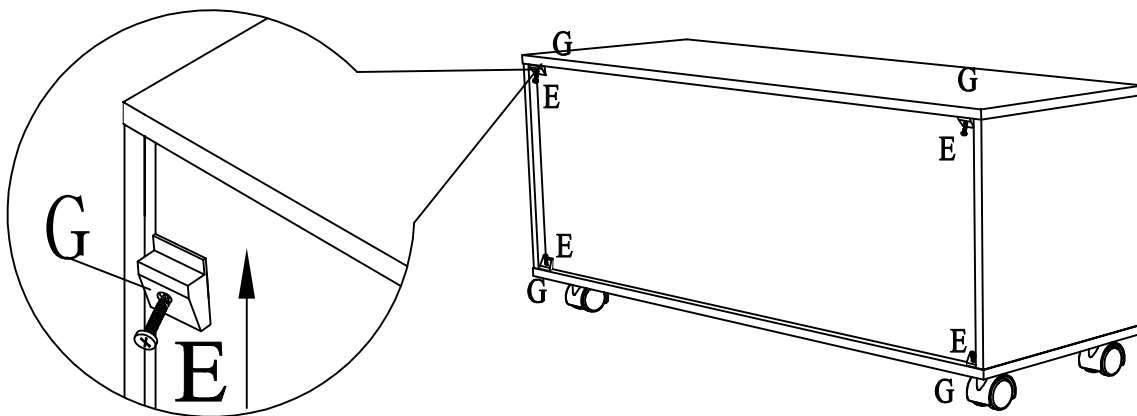

<p>G</p> <p>x4</p>	<p>E</p> <p>M3x 16mm x4</p>
---------------------------	--

7

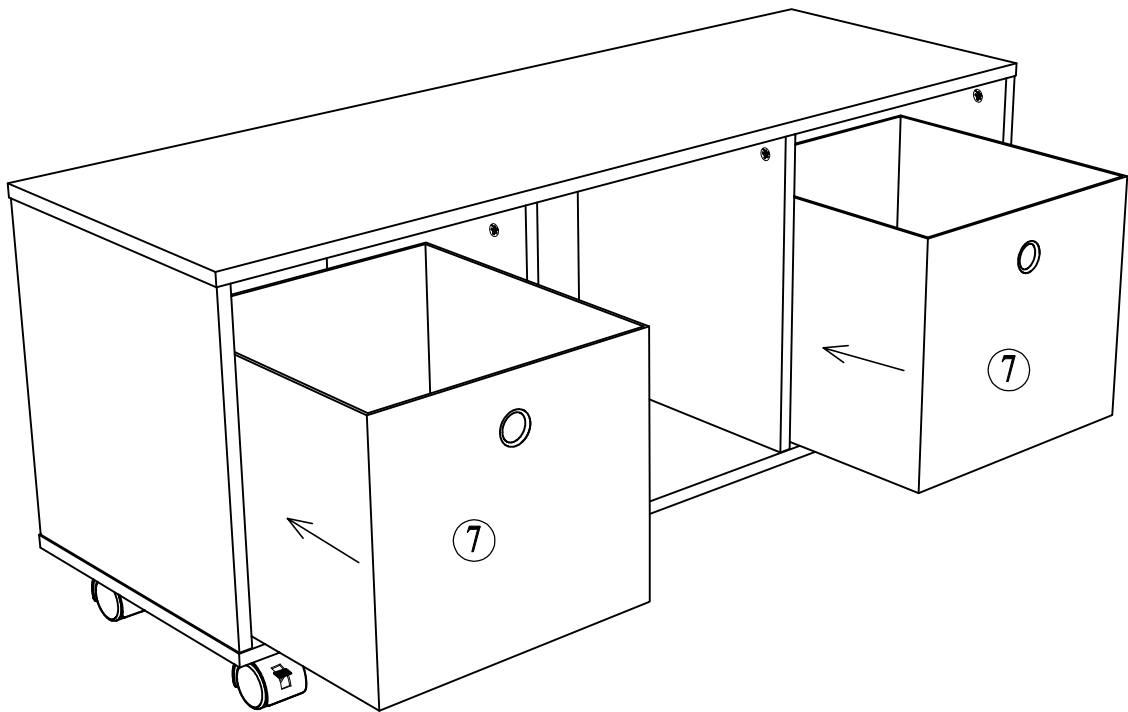

Carton	Reference No.	Quantity
1/1	1	1
1/1	2	1
1/1	3	1
1/1	4	1
1/1	5	2
1/1	6	1
1/1	7	2
1/1	Accessories	1

