

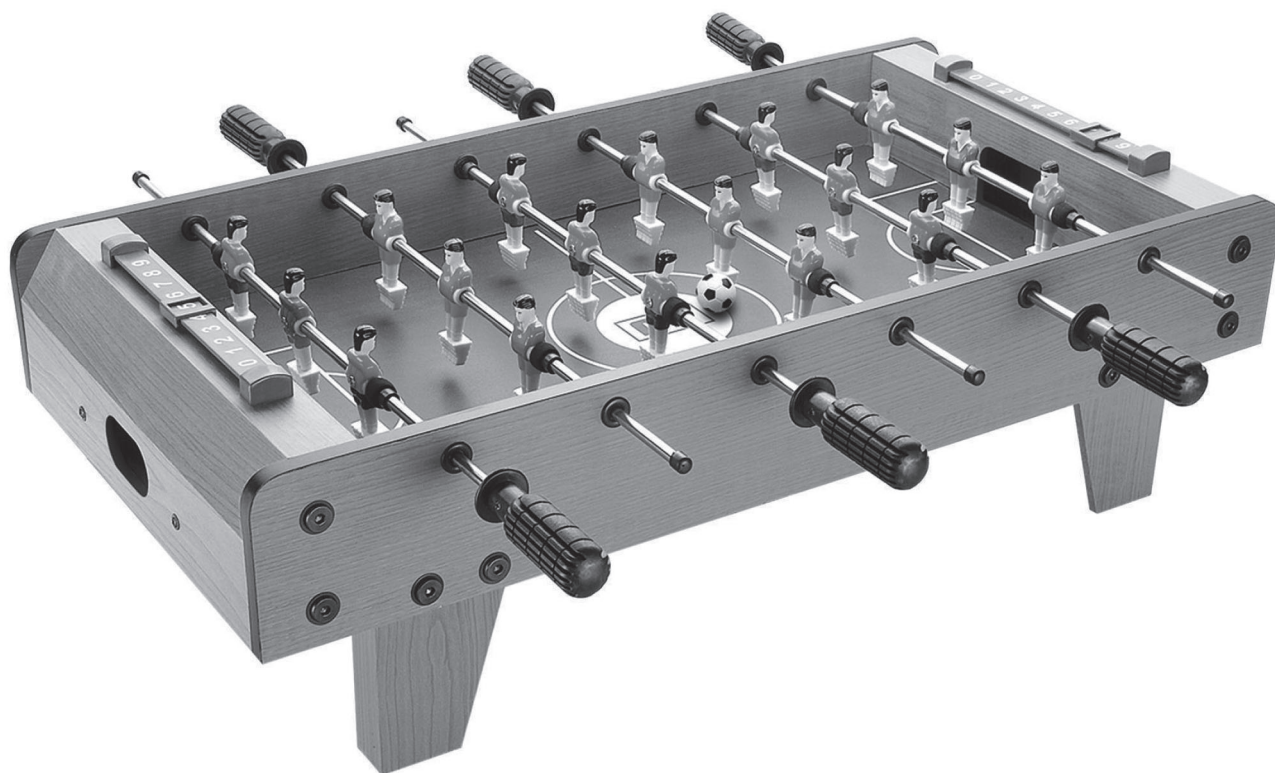

IN220901656V03_FR_ES_PT

A70-021V01



- *Suitable for children of 6+ years old.
- *Convient aux enfants de 6+ ans.
- *Adecuado para los niños de 6+ años.
- *Adequado para crianças de 6+ anos.



EN_IMPORTANT, RETAIN FOR FUTURE REFERENCE: READ CAREFULLY.
FR_IMPORTANT: A LIRE ATTENTIVEMENT ET À CONSERVER POUR CONSULTATION
ULTÉRIEURE.
ES_IMPORTANTE, LEA Y GUARDE PARA FUTURAS REFERENCIAS.
PT_IMPORTANTE, GARDE PARA FUTURA REFERÊNCIA, LEIA ATENTAMENTE.

EN

WARNING:

CHOKING HAZARD-Small parts.

Not for children under 3 years.

CAUTIONS: Must assure the product is correctly assembled according to the instruction before use. (The hardware is included in the box) The process of assembly must be done by an adult or under direction of an adult.

This product is suitable for kids aged from 6+.

FR

AVERTISSEMENT:

Risque d'étouffement. Petites pièces.

Attention. Ne convient pas aux enfants de moins de 36 mois.

ATTENTION: Assurez-vous que le produit soit correctement assemblé selon les instructions avant l'utilisation.

(Les outils d'assemblage sont dans la boîte). L'assemblage du produit doit être fait par un adulte ou sous la supervision d'un adulte.

Convient aux enfants de 6+ ans

ES

ADVERTENCIA:

PELIGRO DE ASFIXIA - Piezas pequeñas.

No apto para niños menores de 3 años.

PRECAUCIONES: Debe asegurarse de que el producto está correctamente montado según las instrucciones antes de su uso. (Las herramientas de montaje se incluyen en la caja) El proceso de montaje debe ser realizado por un adulto o bajo la supervisión de un adulto.

Adecuado para los niños de 6+ años.

PT

ATENÇÃO





Risco de Asfixia.



Este brinquedo contém pequenas, não é adequado para crianças menores de 3 anos.

Atenção: Certifique que o brinquedo foi montado corretamente segundo o manual de instruções antes de utilizar. As ferramentas de montagem estão incluídas na caixa. O processo de montagem somente deve ser realizado por um adulto.

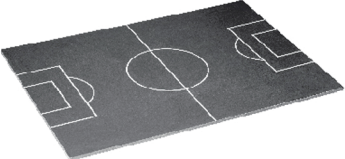
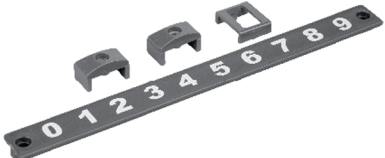
Adequado para maiores de 6 anos.

Part List

P1	2x	
P2	2x	
P3	1x	
P4	2x	
P5	4x	

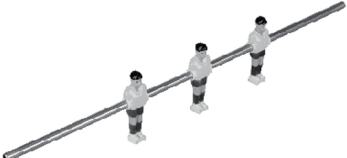
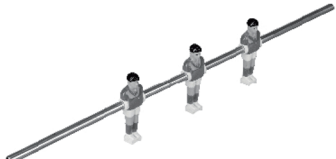
P6	6x	
P7	12x	
P8	6x	
T1	3x	
T2	3x	

S1	1x	
S2	16x	
S5	6x	
S6	2x	

Assembly Instructions

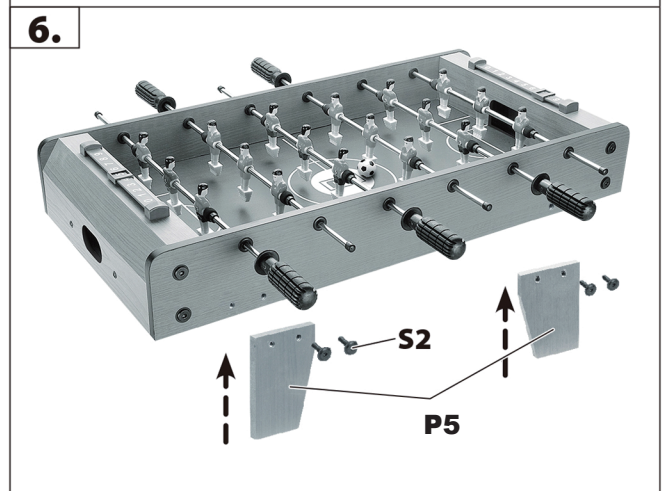
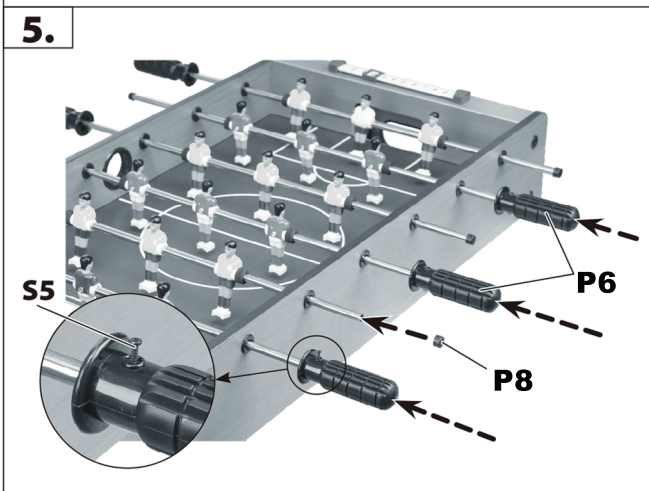
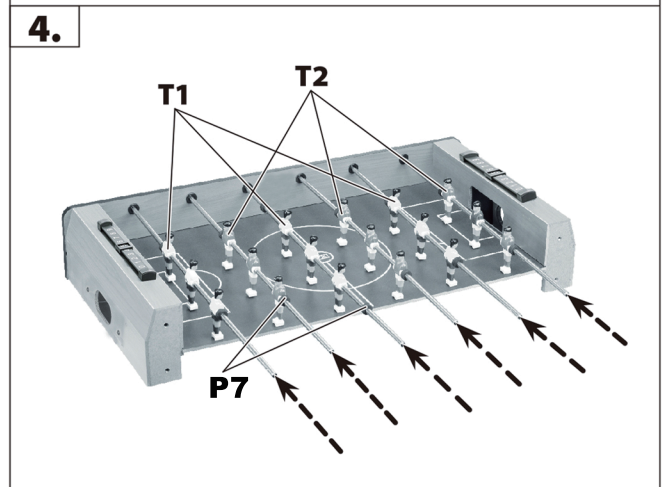
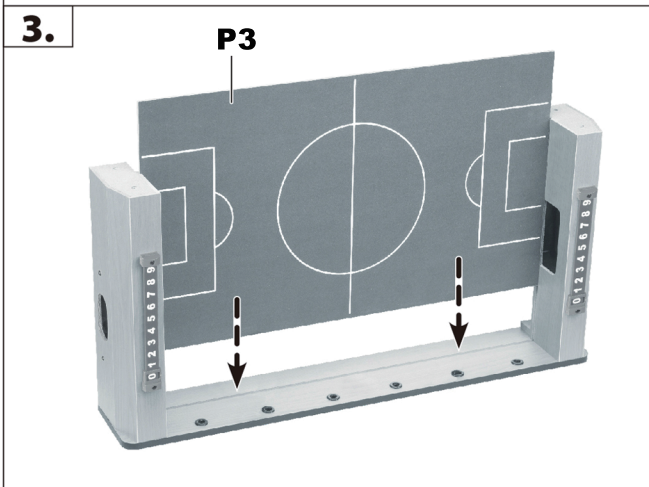
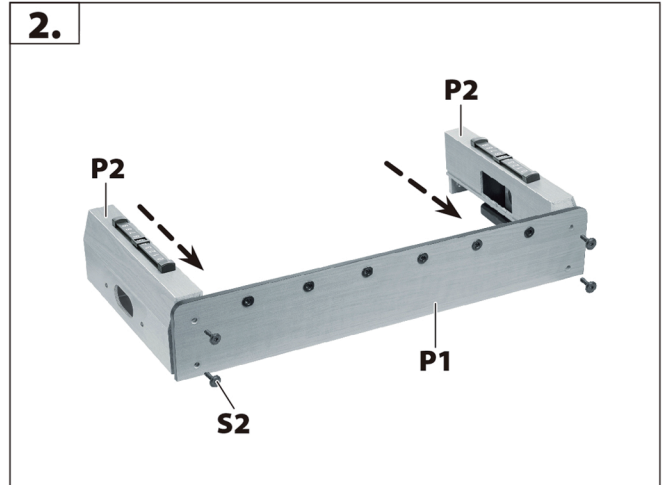
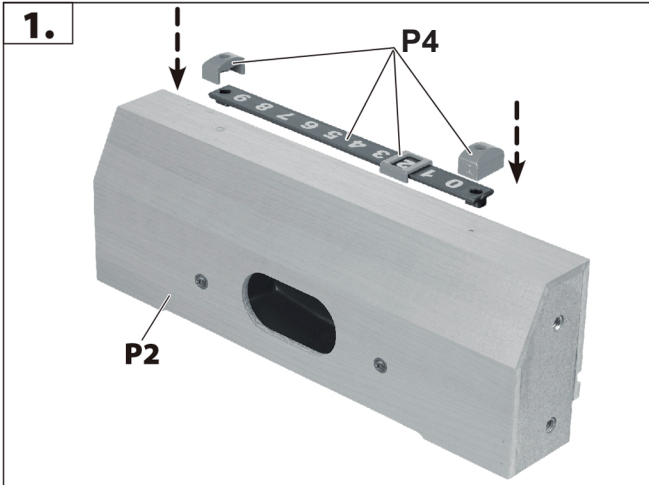

UK

If you have any questions, please contact our customer care center.

Our contact details are below:



0044-800-240-4004



enquiries@mhstar.co.uk

IMPORTER ADDRESS:

MH STAR UK LTD

Unit 27, Perivale Park,
Horsenden lane South
Perivale, UB6 7RH
MADE IN CHINA

ES

Si tiene alguna pregunta, comuníquese con nuestro Centro de Atención al Cliente. Nuestros datos de contacto son los siguientes:



0034-931294512



atencioncliente@aosom.es

IMPORTADOR:

SPANISH AOSOM, S.L.

C/ ROC GROS, N° 15. 08550, ELS HOSTALETS DE
BALENYÀ, SPAIN.
B66295775

WWW.AOSOM.ES

ATENCIONCLIENTE@AOSOM.ES

TEL: 931294512

HECHO EN CHINA

FR

Si vous avez la moindre question, veuillez contacter notre centre d'assistance à la clientèle.

Nos coordonnées sont les suivantes:



0033-1-84166106



aosom@mhfrance.fr

Importé par:

MH France

2, rue Maurice Hartmann
92130 Issy-les-Moulineaux
France
Fabriqué en Chine

PT

Se tiver alguma dúvida, por favor contacte o nosso Centro de Atendimento ao Cliente. Os nossos dados de contacto são os seguintes:



0034-931294512



info@aosom.pt.

IMPORTADOR:

SPANISH AOSOM, S.L

C.ROC GROS N.15, 08550. ELS HOSTALETS DE BALENYÀ
TEL: 931294512 (SEG-SEX DAS 7:30H ÀS 16:30H)

INFO@AOSOM.PT

WWW.AOSOM.PT

DE

Wenn Sie Fragen haben, wenden Sie sich bitte an unser Kundendienstzentrum.

Unsere Kontaktdaten stehen unten:



0049-0(40)-88307530



service@aosom.de

ADRESSE DES IMPORTEUR:

MH Handel GmbH
Wendenstraße 309
D-20537 Hamburg
Germany
IN CHINA HERGESTELLT

IT

In caso di dubbio, si prega di contattare il nostro centro assistenza clienti. I nostri dettagli di contatto sono di seguito:



0039-0249471447



clienti@aosom.it

IMPORTATO DA:

AOSOM Italy srl

Centro Direzionale Milanofiori

Strada 1 Palazzo F1

20057 Assago (MI)

P.I.: 08567220960

FATTO IN CINA



FR

DONNEZ
OU
RECYCLEZ



OU

ASSOCIATION



OU

LIVRAISON



DÉCHÈTERIE

Adresses sur quefairedemesdechets.fr

Aosom