



1. Suitable age for 18-36 Months.
2. Maximum user weight: 20KGS.
3. Adult assembly required.



IMPORTANT, RETAIN FOR FUTURE REFERENCE: READ CAREFULLY

ASSEMBLY INSTRUCTION

Specification

Item	Specifications
Maximum weight	20KGS
Size	67x40.5x46CM
Available ages	Children at 18-36 months

WARNING:

- (1) This kind of product is fit for the children aged 18-36 month old and maximum load under 20kg maximum load under 20kg.
- (2) **WARNING**-Never leave the child unattended.
- (3) Prevent access to stairs, steps and uneven surface.
- (4) Remove hot liquids, electrical flexes and other potential hazards from reach.
- (5) Prevent collisions with glass in doors, windows and furniture.
- (6) Instruction for routine maintenance and cleaning or washing.
- (7) Before using, this product will be inspected and assembled by the adult.

The notices of installing and changing batteries

- (1) Installing and changing batteries should be fulfilled by adults.
- (2) Install the batteries refer to the picture (1) of the parts: the installation of AAA (1.5V) batteries: open the cover, install the batteries correctly according to the marks of the positive and the negative electrodes , finally put on the cover and fasten the cover.

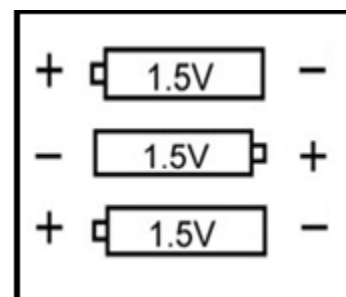

- (3) The unchangeable batteries must not be changed and do not mix the different types of the batteries(or the new and the old) to use together.
- (4) Take out the used-up batteries and avoid short circuit.

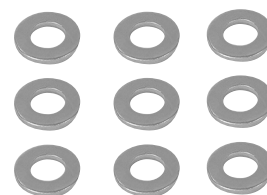

1. body

5. A rear axle &
Axle sleeve

M10

A



2. handlebar



6. Steering shaft

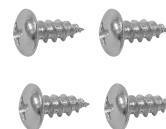

M4*10

B

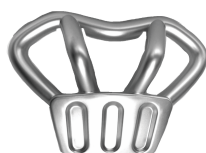

3. Bumper



M8

C



4. wheel*4



M10

D

Note:

All screws, nuts and small plastic parts are pre-installed in the corresponding position, please follow the steps to remove before you install the product.

INSTALLATION STEPS

Step 1 Install the rear wheel

As shown in the arrow, insert the shaft frame into the car body, pass the axle sleeve, gasket, rear wheel, gasket and nut (as shown in Figure 1) through the axle, and tighten the nut clockwise (as shown in Figure 2).

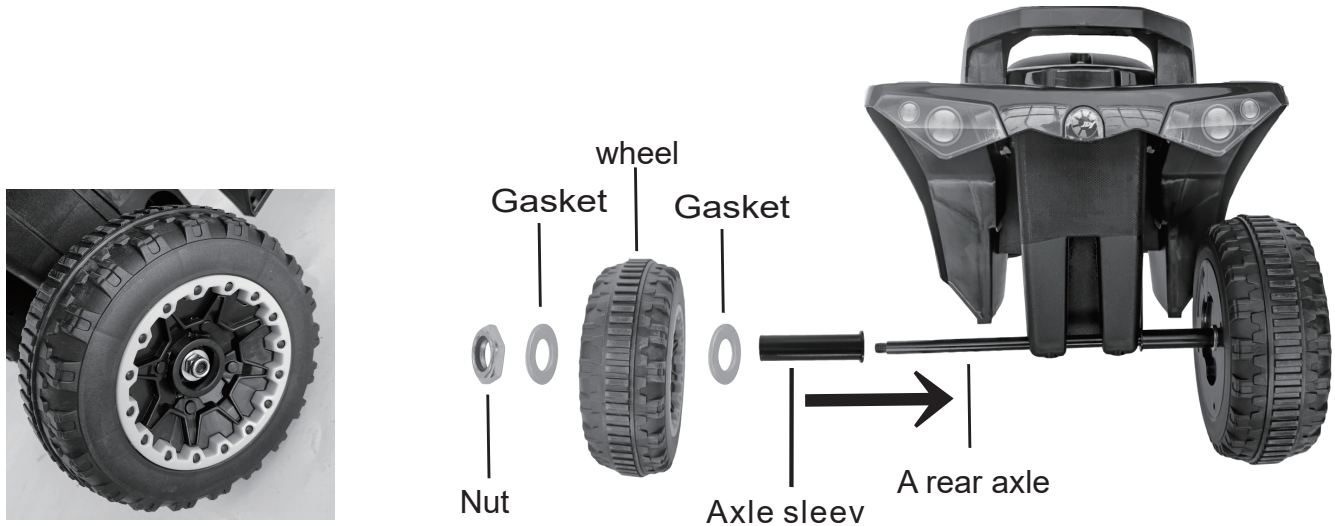
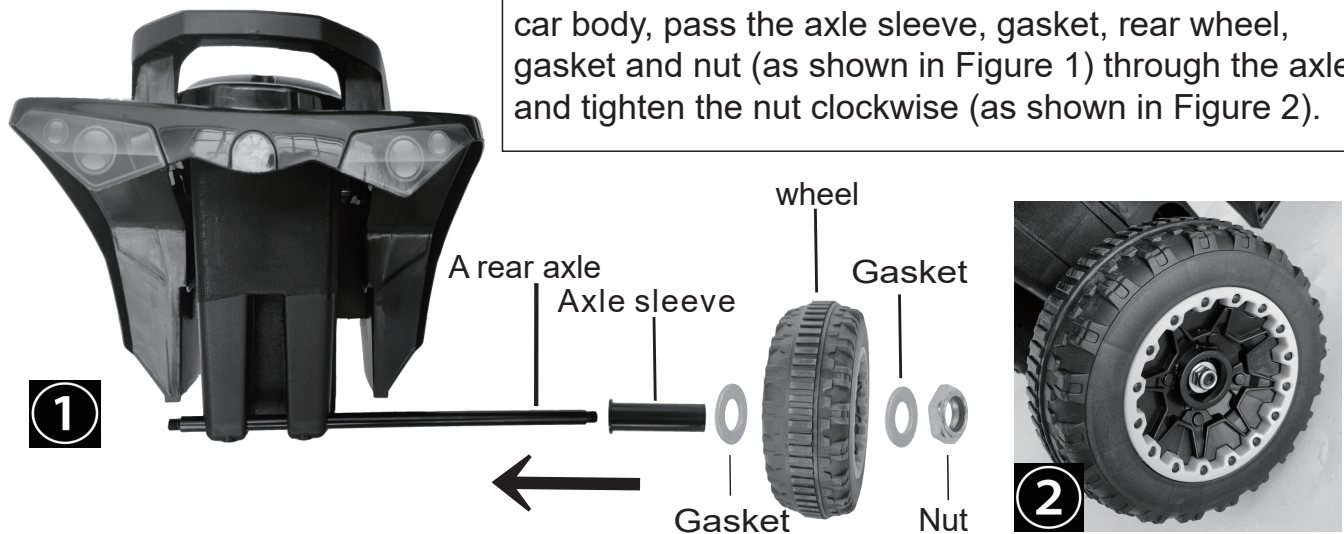

Installing the other side wheel is the same as step 1.

Step 2 Install the bumper

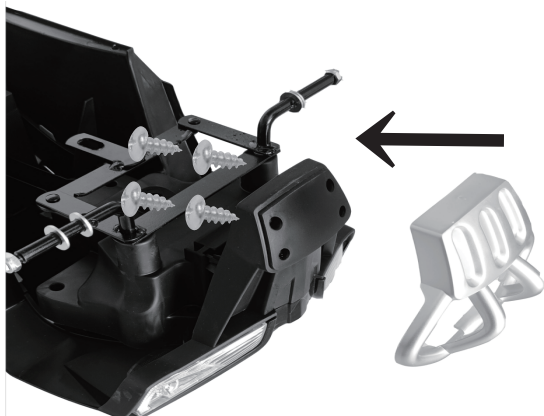

Install the bumper on the front of the car as shown by the arrow and screw it in place (4X(4X10)SCREW)

Step 3 Install front wheel

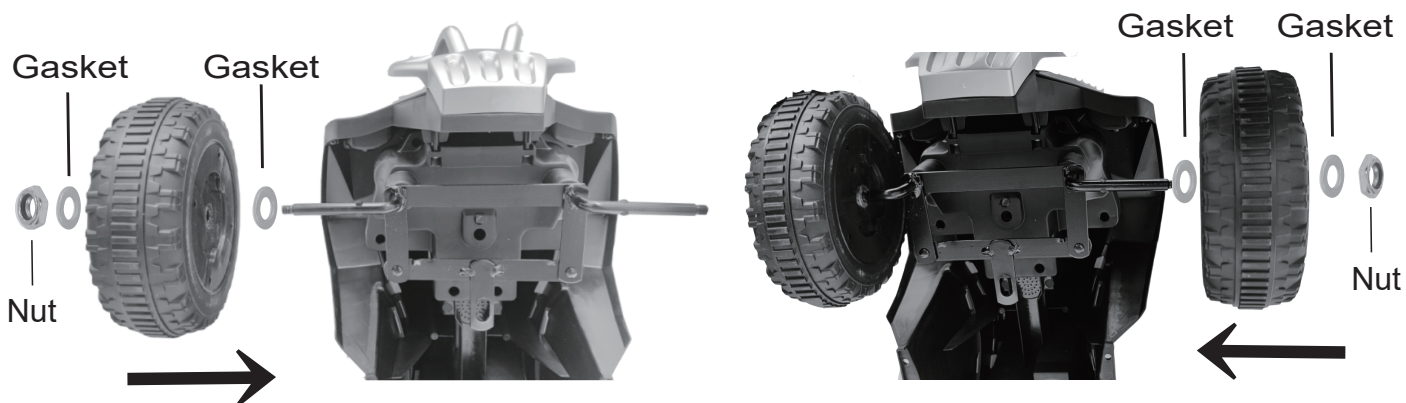

As shown by the arrow, pass the gasket, wheel, gasket and nut through the front axle and tighten the nut clockwise

Step 4 Install the Steering shaft

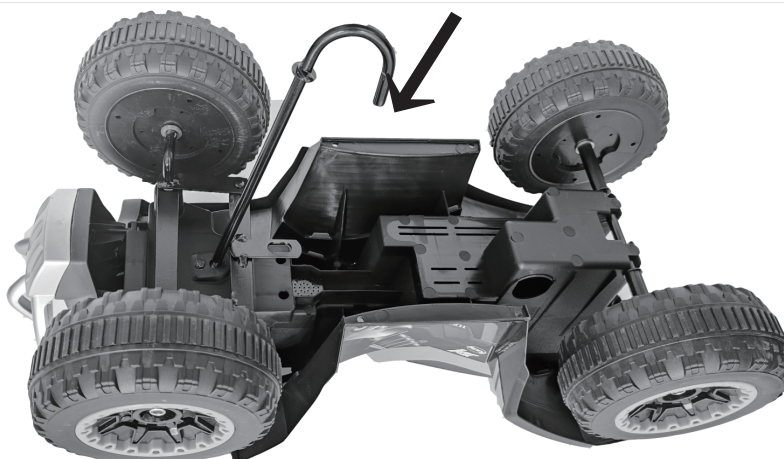

Turn the car upside down and insert the steering shaft

Step 5 Install the Steering shaft



Insert the handlebar into the steering shaft, insert the gasket, and secure with a nut(M10*1)

Step 6 Install the battery

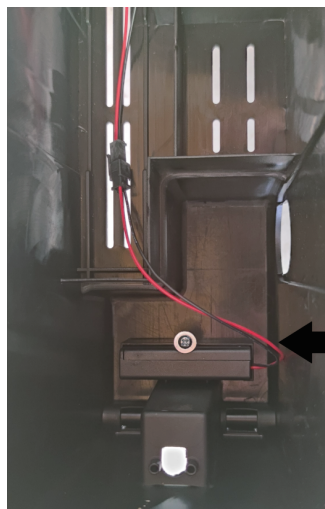

Loosen the 4x10 mounting screws and open the seat cushion to see the battery box. Add the dry battery and you can use the music function.

box and take off the cover;

Use three AAA 1.5V cells, please install the batteries properly.

Warning:

Do not mix to use the batteries, such as used, unused, different type, etc.

Keep the child away from the battery.

UK

If you have any questions, please contact our customer care center.

Our contact details are below:



0044-800-240-4004



enquiries@mhstar.co.uk

IMPORTER ADDRESS:
MH STAR UK LTD
Unit 27, Perivale Park,
Horsenden lane South
Perivale, UB6 7RH
MADE IN CHINA