



IN221000270V02\_US\_CA

**370-096**



**1. Suitable age for 18-36 Months.**

**2. Maximum user weight: 20KGS.**

**3. Adult assembly required.**

**1. Convient pour les enfants de 18 à 36 mois.**

**2. Poids maximum de l'utilisateur : 20KGS.**

**3. Un adulte est nécessaire pour l'assemblage.**

**IMPORTANT, RETAIN FOR FUTURE REFERENCE: READ CAREFULLY**

**IMPORTANT : LIRE ATTENTIVEMENT ET CONSERVEZ CE MANUEL POUR VOUS Y REFERER ULTERIEUREMENT**

**ASSEMBLY INSTRUCTION**

**Specification**

Item	Specifications
Maximum weight	20KGS
Size	67x40.5x46CM
Available ages	Children at 18-36 months

**WARNING:**

- (1) This kind of product is fit for the children aged 18-36 month old and maximum load under 20kg maximum load under 20kg.
- (2) **WARNING**-Never leave the child unattended.
- (3) Prevent access to stairs, steps and uneven surface.
- (4) Remove hot liquids, electrical flexes and other potential hazards from reach.
- (5) Prevent collisions with glass in doors, windows and furniture.
- (6) Instruction for routine maintenance and cleaning or washing.
- (7) Before using, this product will be inspected and assembled by the adult.

**The notices of installing and changing batteries**

- (1) Installing and changing batteries should be fulfilled by adults.
- (2) Install the batteries refer to the picture (1) of the parts: the installation of AAA (1.5V) batteries: open the cover, install the batteries correctly according to the marks of the positive and the negative electrodes , finally put on the cover and fasten the cover.
- (3) The unchangeable batteries must not be changed and do not mix the different types of the batteries( or the new and the old) to use together.
- (4) Take out the used-up batteries and avoid short circuit.

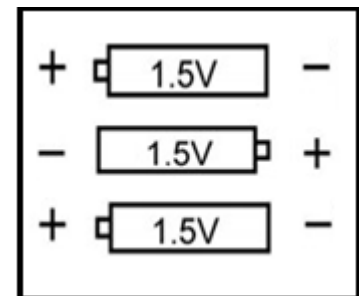





1. body



5. A rear axle & Axle sleeve

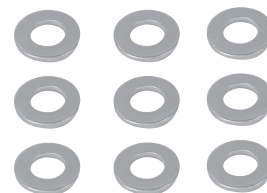

M10

**A**



2. handlebar



6. Steering shaft

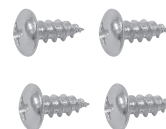

M4\*10

**B**



3. Bumper



M8

**C**



4. wheel\*4



M10

**D**

## INSTALLATION STEPS

### Step 1 Install the rear wheel

As shown in the arrow, insert the shaft frame into the car body, pass the axle sleeve, gasket, rear wheel, gasket and nut (as shown in Figure 1) through the axle, and tighten the nut clockwise (as shown in Figure 2).



**1**

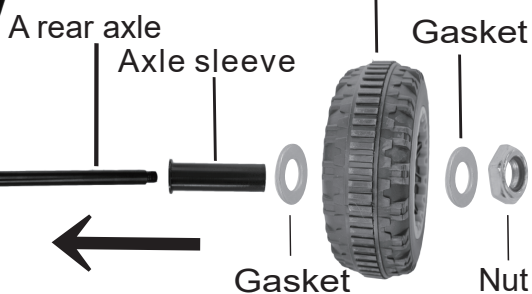

**2**

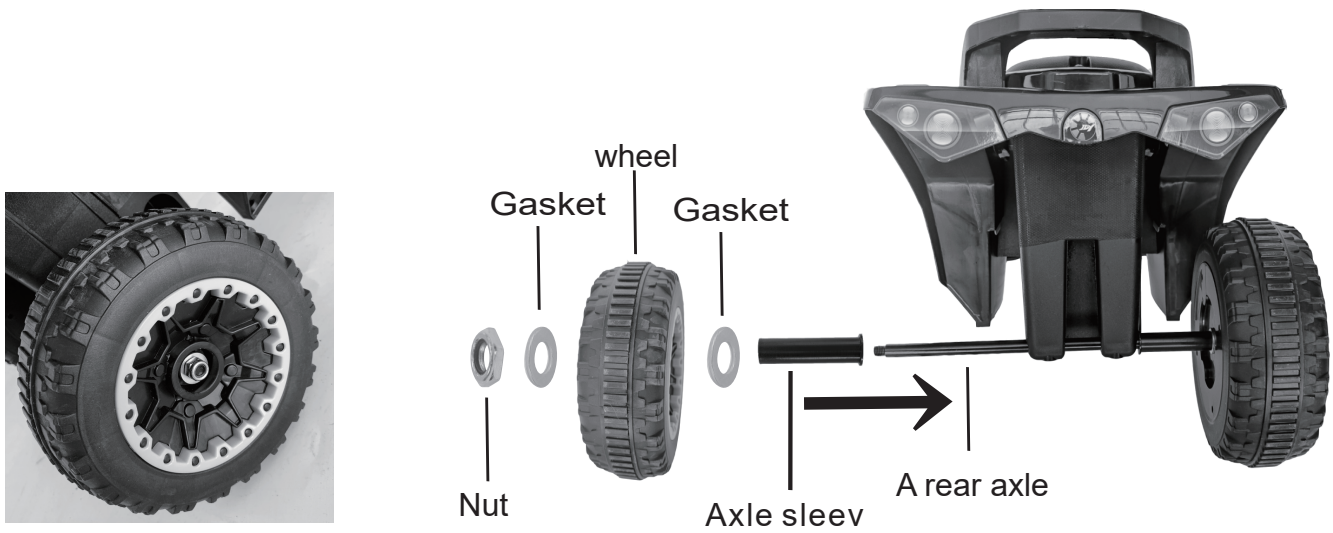

Installing the other side wheel is the same as step 1.

## Step 2 Install the bumper

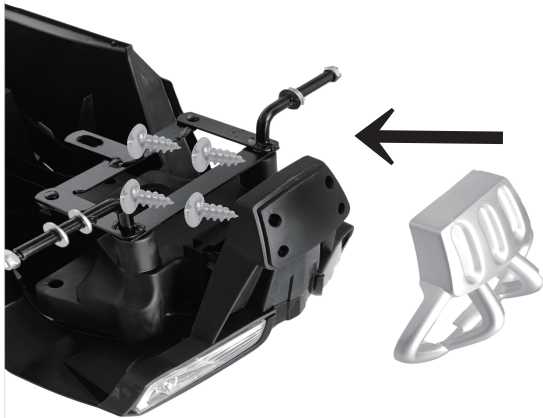

Install the bumper on the front of the car as shown by the arrow and screw it in place (4X(4X10)SCREW)

## Step 3 Install front wheel

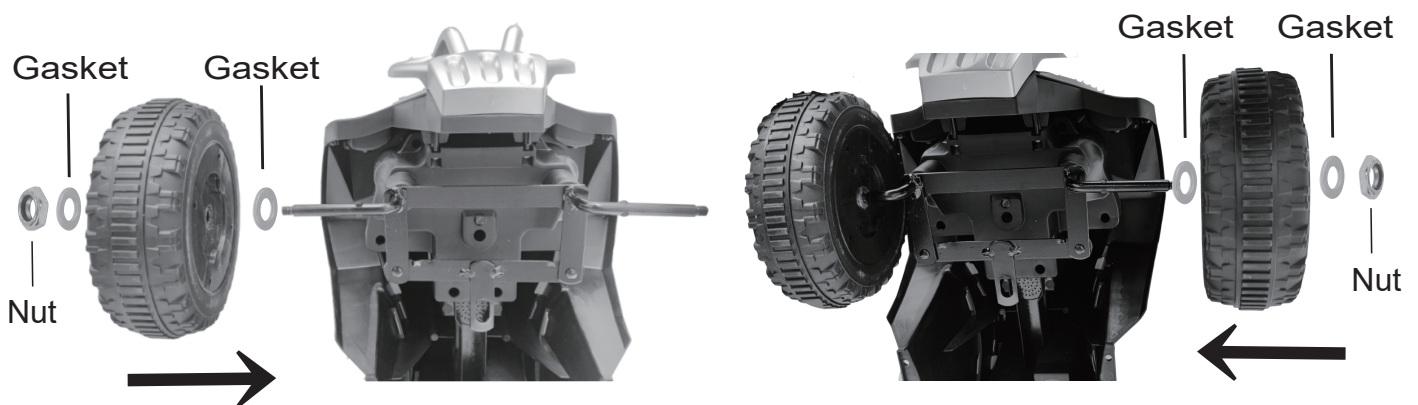

As shown by the arrow, pass the gasket, wheel, gasket and nut through the front axle and tighten the nut clockwise

## Step 4 Install the Steering shaft

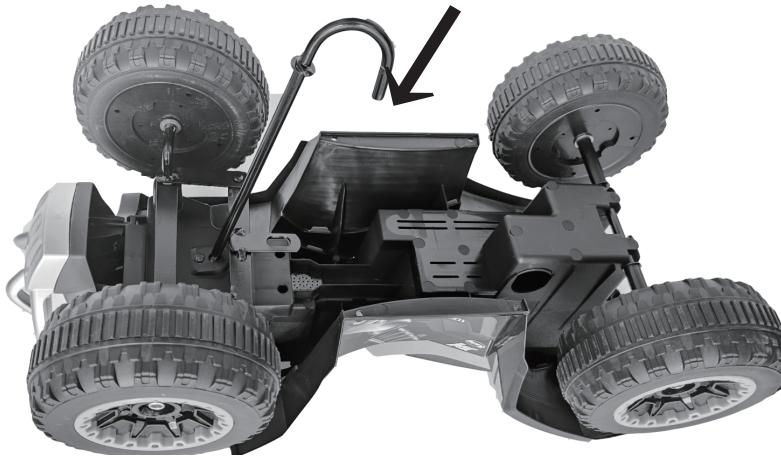

Turn the car upside down and insert the steering shaft

## Step 5 Install the Steering shaft



Insert the handlebar into the steering shaft, insert the gasket, and secure with a nut(M10\*1)

## Step 6 Install the battery

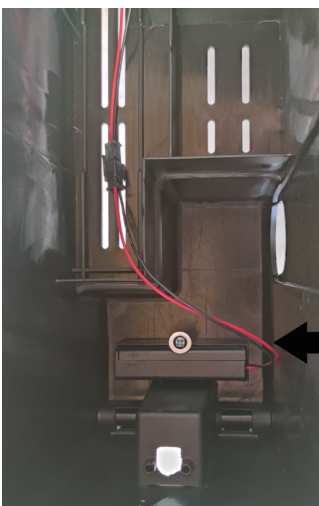

Loosen the 4x10 mounting screws and open the seat cushion to see the battery box. Add the dry battery and you can use the music function.

box and take off the cover;  
Use three AAA 1.5V cells, please install the batteries properly.

**Warning:**

Do not mix to use the batteries, such as used, unused, different type, etc.

Keep the child away from the battery.



Spécification	Item	Spécifications
	Poids maximum	20KGS
	Taille	67x40.5x46CM
	Âges disponibles	Enfants de 18 à 36 mois

**AVERTISSEMENT :**

- (1) Ce type de produit convient aux enfants âgés de 18 à 36 mois et à une charge maximale inférieure à 20 kg.
- (2) AVERTISSEMENT-ne laissez jamais l'enfant sans surveillance.
- (3) Empêchez l'accès aux escaliers, aux marches et à la surface inégale
- (4) Mettez les liquides chauds, les flexions électriques et d'autres dangers potentiels hors de portée.
- (5) Prévenez les collisions avec du verre dans les portes, les fenêtres et les meubles.
- (6) Instructions pour l'entretien de routine et le nettoyage ou le lavage.
- (7) Ce produit sera inspecté et assemblé par l'adulte avant utilisation.

**Avis d'installation et de remplacement de batteries**

- (1). L'installation et le remplacement des batteries doivent être effectués par les adultes
- (2). L'installation des batteries se réfère aux figures (1) des pièces :

l'installation de batteries AAA (1.5V):  
ouvrez le couvercle, installez les batteries correctement en fonction des marques des électrodes positives et négatives, enfin mettez en place le couvercle et fixez le couvercle.

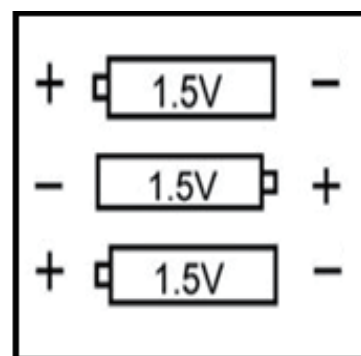

- (3). Les batteries non interchangeables ne doivent pas être changées et ne doivent pas mélanger les différents types de piles (ou la nouvelle et l'ancienne) à utiliser ensemble.
- (4). Retirez les batteries usagées et évitez le court-circuit.

**NOTE :**

Toutes les vis, écrous et petites pièces en plastique sont préinstallés dans leur position correspondante, veuillez suivre les étapes pour les retirer avant d'installer le produit.



1. Carrosserie



5. Essieu arrière et Manchon d'essieu

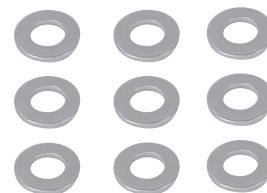

**A**

M10



2. Guidon



6. Lenkwelle

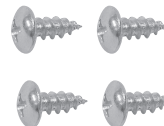

**B**

M4\*10



3. Pare-chocs



**C**

M8



4. Roues \*4



**D**

M10

## ÉTAPES D'INSTALLATION

### Étape 1 Installer la roue arrière

Comme indiqué dans la flèche, insérez le cadre de l'arbre dans la carrosserie du véhicule, faites passer le manchon d'essieu, le joint, la roue arrière, le joint et l'écrou (comme indiqué dans la figure 1) à travers l'essieu, et serrez l'écrou dans le sens des aiguilles d'une montre (comme indiqué dans la figure 2).



**1**

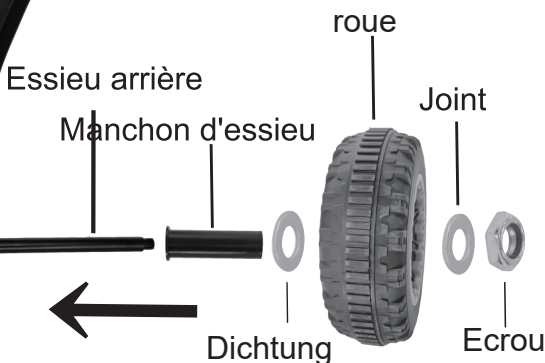

**2**

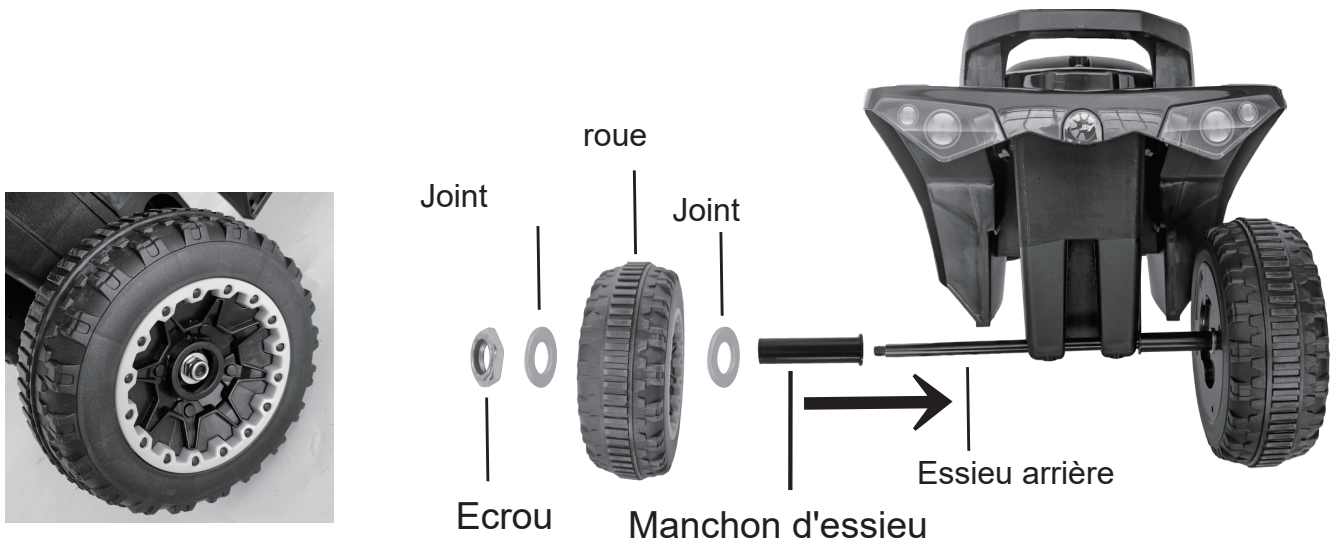

Der Einbau des anderen Seitenrades erfolgt gemäß Schritt 1.

## Étape 2 Installer le pare-chocs

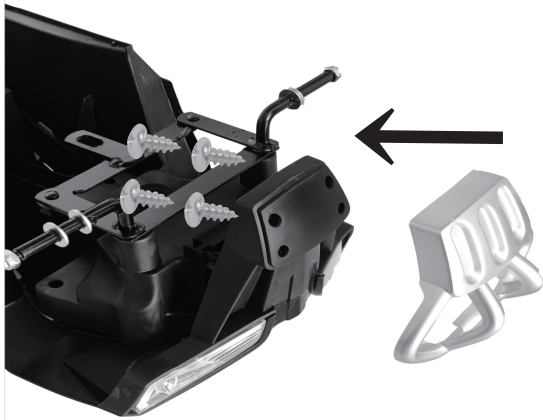

Installez le pare-chocs à l'avant de la voiture comme indiqué par la flèche et vissez-le en place (vis 4X(4X10))

## Étape 3 Installer la roue avant

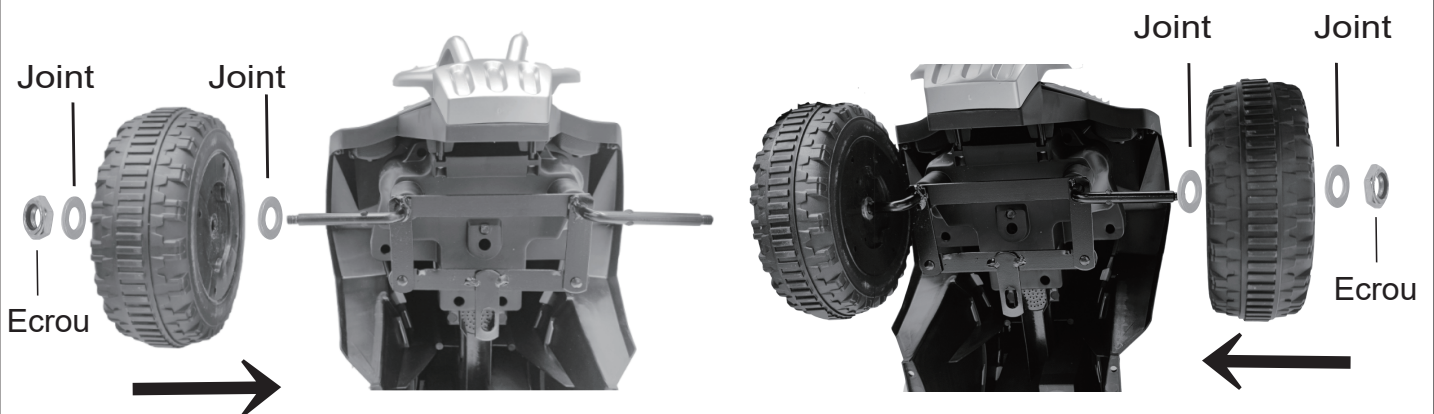

Comme indiqué par la flèche, faites passer le joint, la roue, le joint et l'écrou par l'essieu avant et serrez l'écrou dans le sens des aiguilles d'une montre



## Étape 4 Installer l'Axe de direction

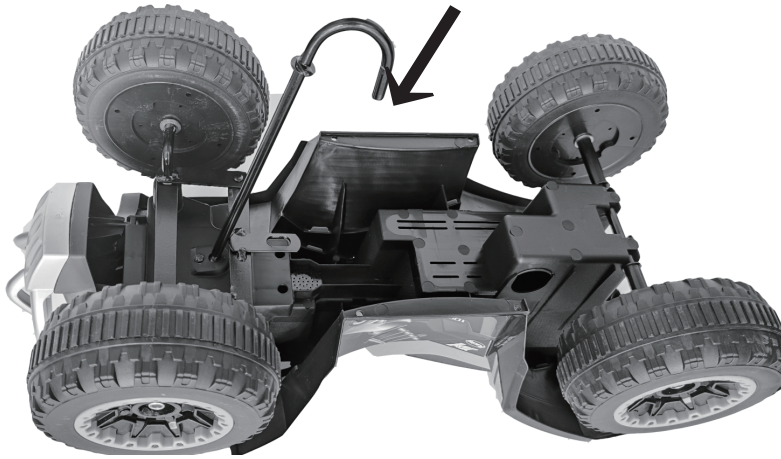

Retournez la voiture et insérez l'arbre de direction.

## Étape 5 Installation de l'axe de direction



Insérer le guidon dans l'arbre de direction, insérer le joint, et fixer avec un écrou (M10\*1)

## Étape 6 Installer les piles

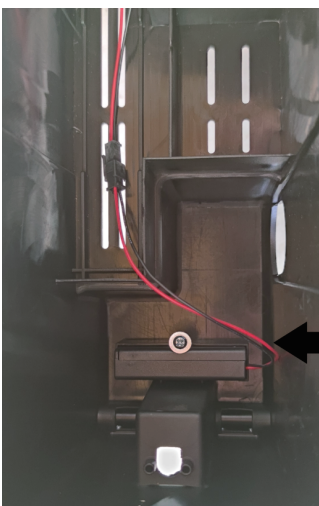

Desserrez les vis de fixation 4x10 et ouvrez le coussin du siège pour voir le boîtier de piles. Ajoutez la pile sèche et vous pouvez utiliser la fonction musique. boîte et enlevez le couvercle ; Utilisez trois piles AAA 1,5V, veuillez installer les piles correctement. Attention : Ne mélangez pas les piles pour les utiliser, comme par exemple des piles usagées, inutilisées, les piles de type différent, etc. Tenez l'enfant éloigné de la pile.

Traduit avec [www.DeepL.com/Translator](http://www.DeepL.com/Translator) (version gratuite).

## US

If you have any questions, please contact our customer care center.  
Our contact details are below:



001-877-644-9366



customerservice@aosom.com

Imported by Aosom LLC  
27150 SW Kinsman Rd Wilsonville, OR 97070 USA  
Manufactured in Ningbo City, Zhejiang Province, China  
MADE IN CHINA

## CA

If you have any questions, please contact our customer care center.  
Our contact details are below:  
Si vous avez la moindre question, veuillez contacter notre centre d'assistance à la clientèle.  
Nos coordonnées sont les suivantes:



416-792-6088



customerservice@aosom.ca

Imported by Aosom Canada Inc.  
7270 Woodbine Avenue, Unit 307, Markham, Ontario Canada  
L3R 4B9  
Manufactured in Ningbo City, Zhejiang Province, China  
MADE IN CHINA

Importé par Aosom Canada Inc.  
7270 Woodbine Avenue, unité 307, Markham, Ontario Canada  
L3R 4B9  
Fabrique dans la ville de Ningbo, Province de Zhejiang, Chine  
Fabriqué en Chine