



CHILDREN'S ELECTRONIC MOTORCYCLE

- Suitable for 3+ Years
- Maximum user weight: 30 kg



WARNING: Must be assembled by an adult.

Read and understand this entire manual before using!

Please keep this manual for future reference as it contains important information. Before first time use, charge the battery for at least 4-6 hours, but no more than 10hours.

IMPORTANT, RETAIN FOR FUTURE REFERENCE: READ CAREFULLY

ASSEMBLY INSTRUCTION

On the purchase of your new Ride-On.

This ride-on car will provide your child with many miles of riding of enjoyment. To help assure you and your rider a safe ride we ask you to please read this manual carefully, and keep it for future reference.

Follow the recommendations in this manual, they are designed to improve the safety and operation of your ride-on car and its rider.

Specification

Battery	12V4.5AH X1
Charger	12V500mA
input	Depend on local voltage
Motor	12V390-16000
Speed	3.8-5.8 km/h

Suitable age:	3+ Years
Charge time:	8-12 hours
Load capacity:	Under 30 kg
Size of car:	1065×515×680MM



BATTERY INFORMATION

- Non-rechargeable batteries are not to be recharged.
- If removable rechargeable batteries are used, they are only to be charged under adult supervision.
- Remove rechargeable batteries from the product before charging.
- Do not mix old and new batteries. Do not mix different types of batteries: alkaline, standard (carbon-zinc) or rechargeable (nickel-cadmium).
- Insert batteries as indicated inside the battery compartment, anode to anode, cathode to cathode.
- Remove batteries during long periods of non-use. Always remove exhausted batteries from the product. Battery leakage and corrosion can damage this product. Dispose of batteries safely.
- Never short circuit the battery terminals.

NO.	PART NAME	Q'TY (PCS)		REMARK
1	Vehicle body	1		
2	Front wheel	1		
3	Front fork	1		
4	Handle bar	1		
5	Handle bar cover	2		
7	Front axle	1		
9	Charger	1		
12	Side wheel	2		
13	Seat	1		
14	Spanner	2		
Hardware				
6	Ø8 lock nut	8		pre-installed
8	Ø8 washer	3		pre-installed
10	Ø4x12 screws	6		
11	M8x150 bolt	1		pre-installed
15	Ø10 washer	2		

Assembly tools required (not included):



Screwdriver

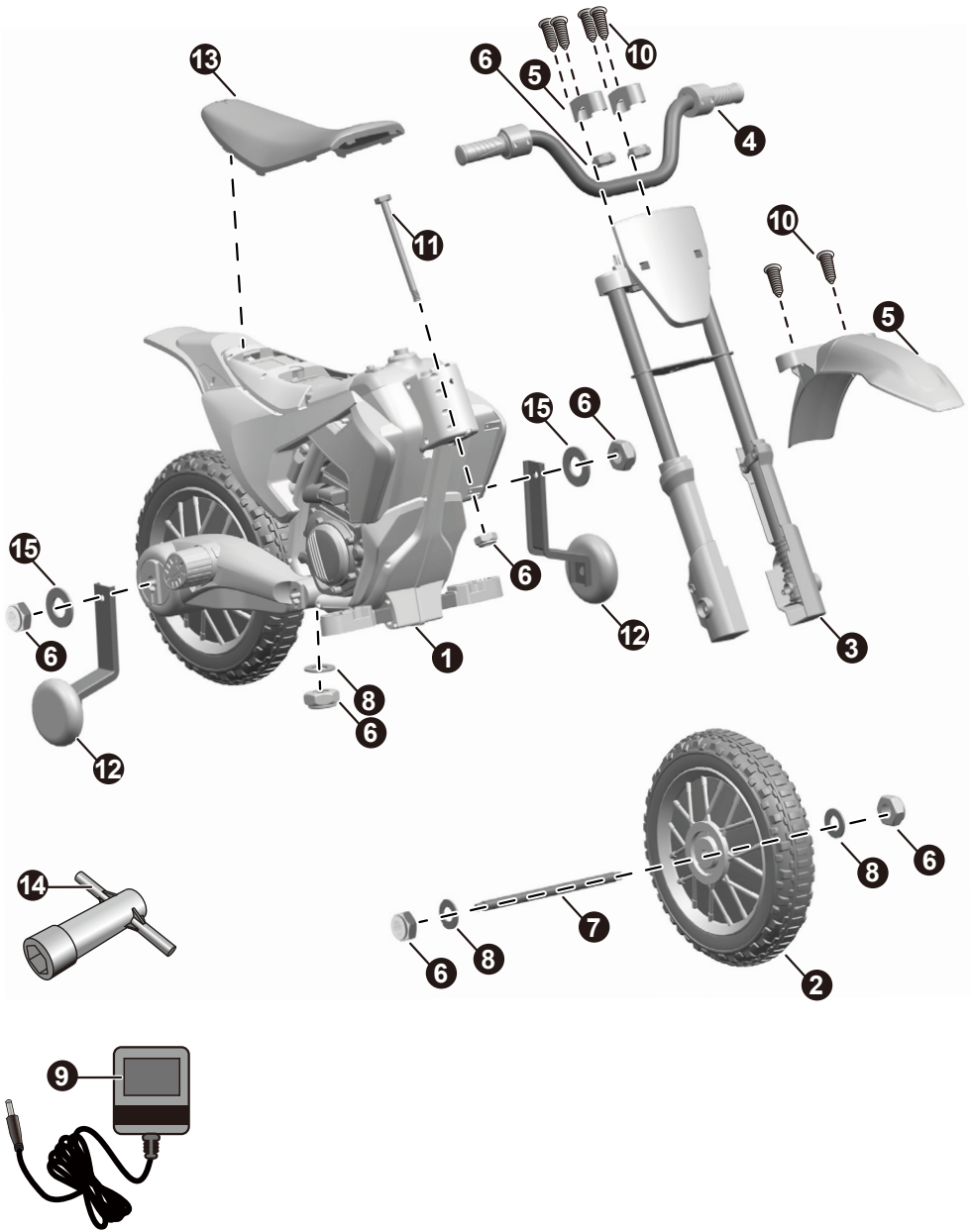

**PREVENT INJURIES AND DEATHS:**

- **NEVER LEAVE CHILD UNATTENDED. ADULT DIRECT SUPERVISION IS REQUIRED.** Always keep child in view when child is in vehicle.
- This toy should be used with caution since skill is required to avoid falls or collisions causing injury to the user or third parties.
- Protective equipment should be worn.
- Never use in roadways, near cars, or on near steep inclines or steps, swimming pools or other bodies of water.
- Always wear shoes, always sit on the seat.
- Not to be used in traffic.
- This toy is unsuitable for children under 36 months due to its maximum speed; Maximum user weight is 30 kg.
- This toy has no brake.

**WARNING:**

- **CHOKING HAZARD!** Not suitable for children under 36 months.
- **Must be assembled by an adult.**

Rules for Safe Riding

- **To reduce the risk of injury, adult supervision is required. Never use in roadways, near motor vehicles, on or near steep inclines or steps, swimming pools or other bodies of water, always wear shoes, and never allow more than 1 rider.**
- Use the toy only on flat surfaces. Such as inside your house, garden or playground.
- Never use in the dark. A child could encounter unexpected obstacles and have an accident. Operate the vehicle only in the daytime or a well-lit area.
- It is prohibited to change the circuit or add other electric parts
- Inspect wires and connections of the vehicle periodically.
- Do not let any child touch the wheels or be near them when the car is moving .

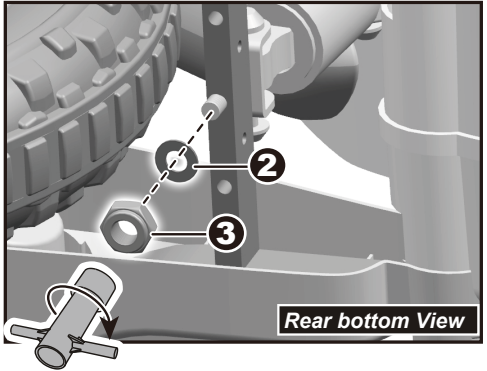
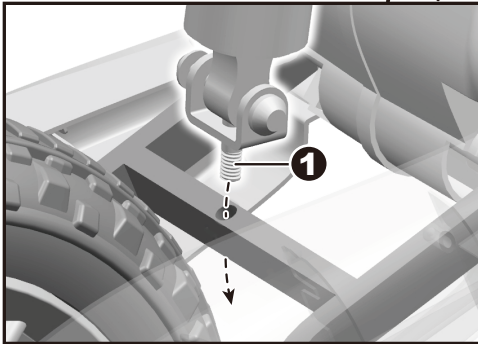
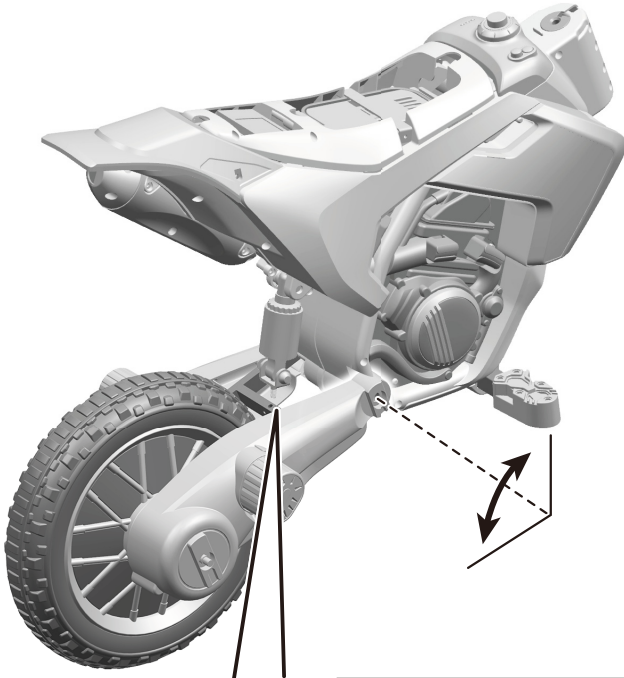

1. Rotate the rear wheel frame until the bolt of the rear shock absorber is inserted into the hole on the rear wheel frame.
2. Turn the vehicle body on its side. Slide a $\varnothing 8$ washer onto the front axle.
3. Tighten a lock nut to the end of the bolt with a spanner.

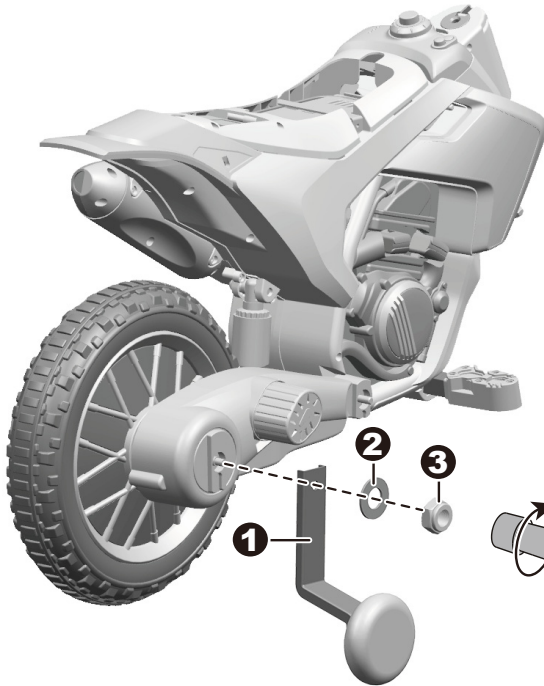

1. Fit the side wheel to the vehicle body.
2. Slide a **Ø10 washer** onto the rear axle.
3. Tighten a lock nut to the end of the rear axle with a spanner.

Repeat for the other side.

4. Fit the front fender to the front fork.
5. Insert and tighten two **Ø4x12 screws** with a screwdriver.

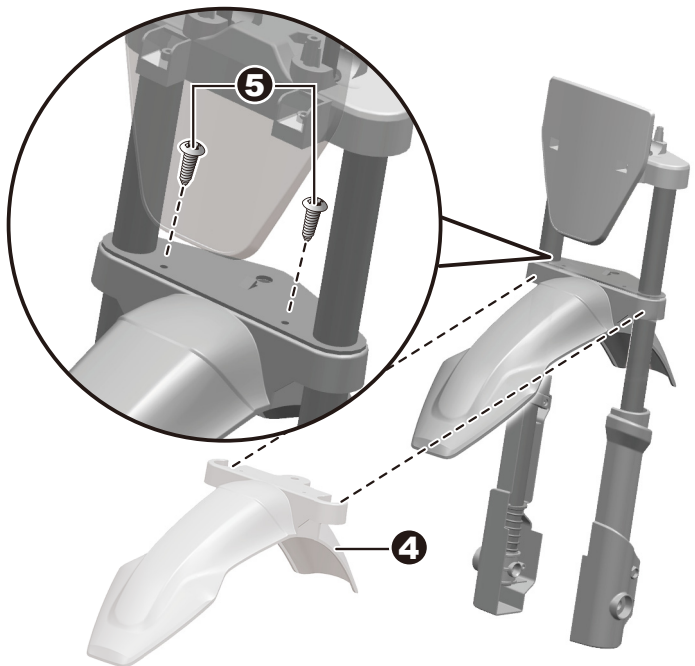

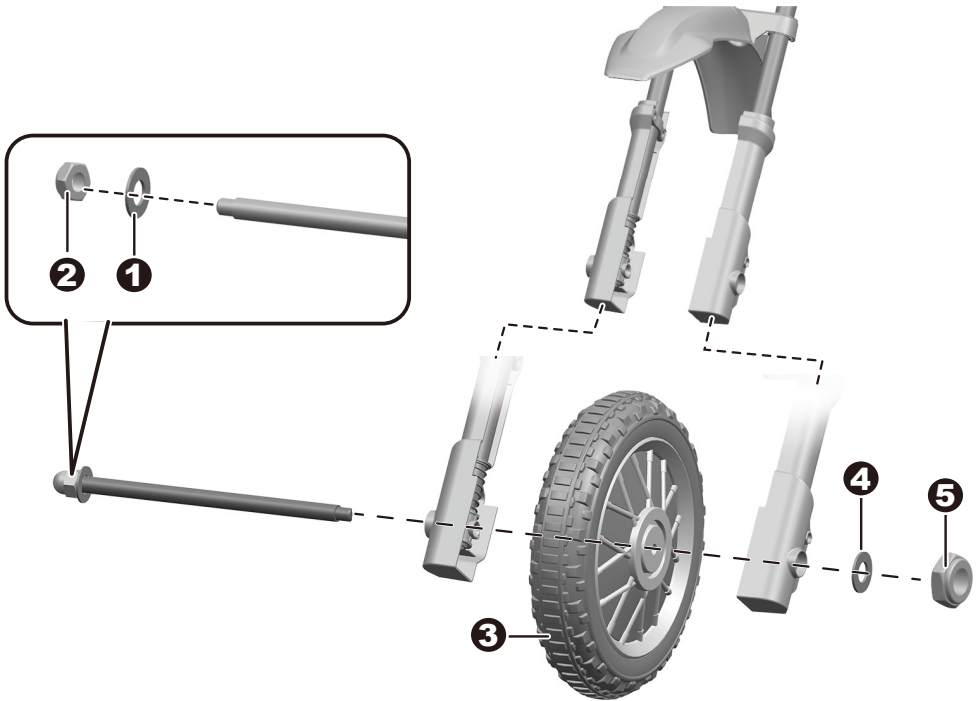

Remove the lock nuts and front axle from the front fork.

- 1-2. Slide a $\varnothing 8$ washer to one end of the front axle. Tighten a lock nut to the end of the front axle with a spanner.
3. Insert the front axle through the hole on one side of the front fork, then through the hole in the center of the front wheel, and continue to push the front axle through the hole on the other side of the fork.
4. Slide a $\varnothing 8$ washer to the front axle.
5. Use a spanner to tighten the lock nut into the front axle. Tip: Use two spanners to tighten the lock nuts on both sides of the front axle at the same time, but do not overtighten them, to ensure that the front wheel can rotate freely.

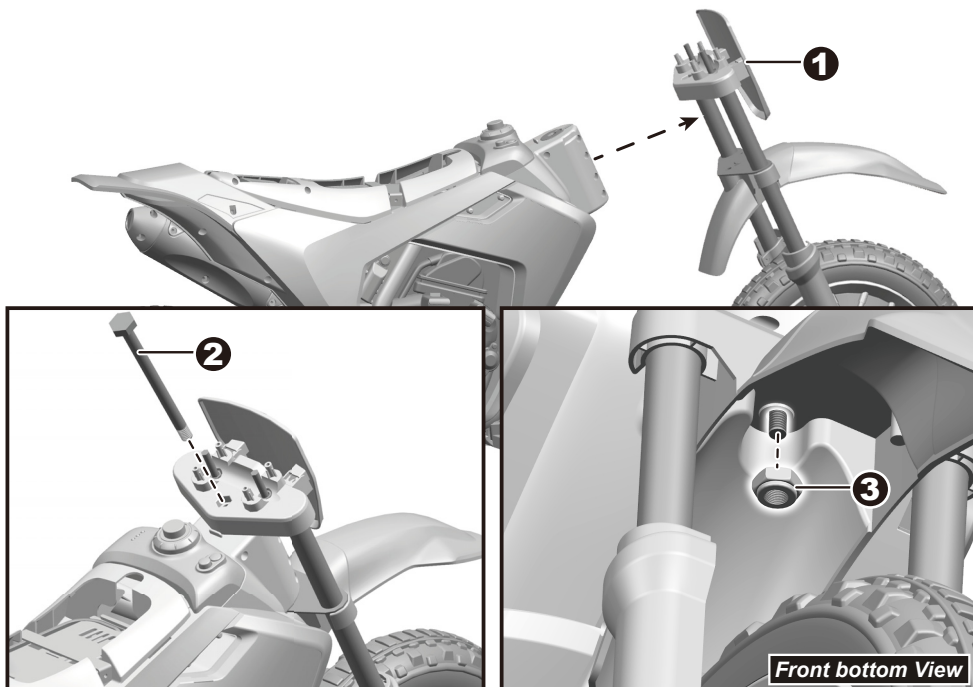

1. Fit the front fork assembly to the vehicle body.

2. Align the holes on each side of front fork with the holes on the vehicle body. Insert the M8x150 bolt into the hole on top of the front fork, through the holes on vehicle body, and out through the hole on the bottom of the front fender

3. Lift up the front fork and tighten a locknut to the end of the M8x150 bolt with a spanner from the bottom side.

4. Fit the handle to the front fork.

5. Tighten two lock nuts with a spanner to secure the handle bar to the front fork.

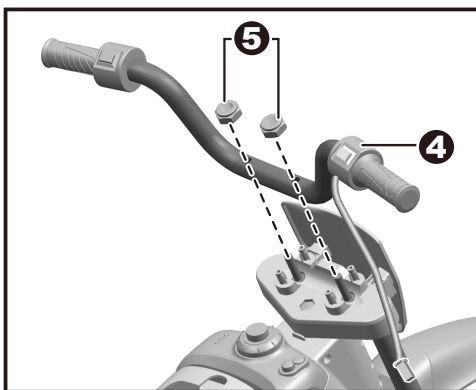

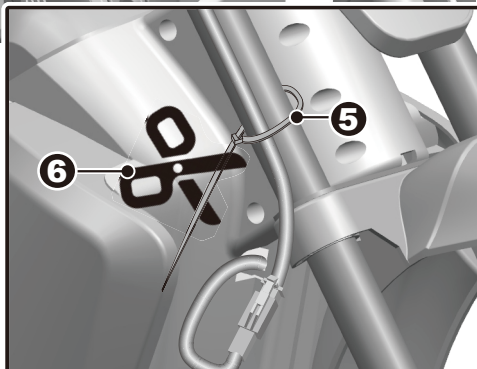
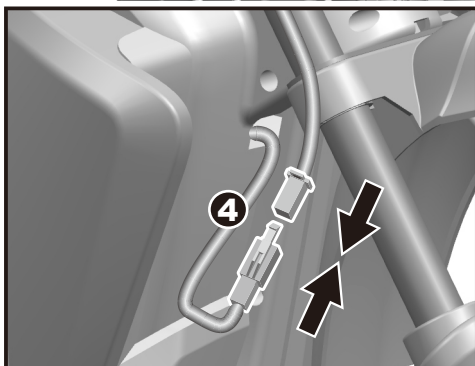
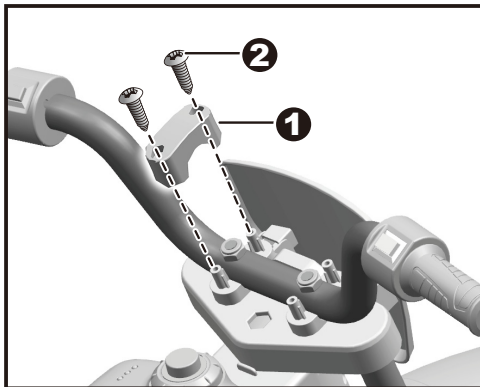

- 1-2. Fit the handle bar cover to the front fork. Insert two $\varnothing 4 \times 12$ screws and tighten with a screwdriver. And repeat for other handel bar cover.
3. Pass the wire connector on the right handle bar through the cable tie on the front fork.
4. Plug the wire connector on the handlebar into the connector on the vechiel body.
- 5-6. Tighten the cable tie, then cut off the excess part of the cable tie with scissors.

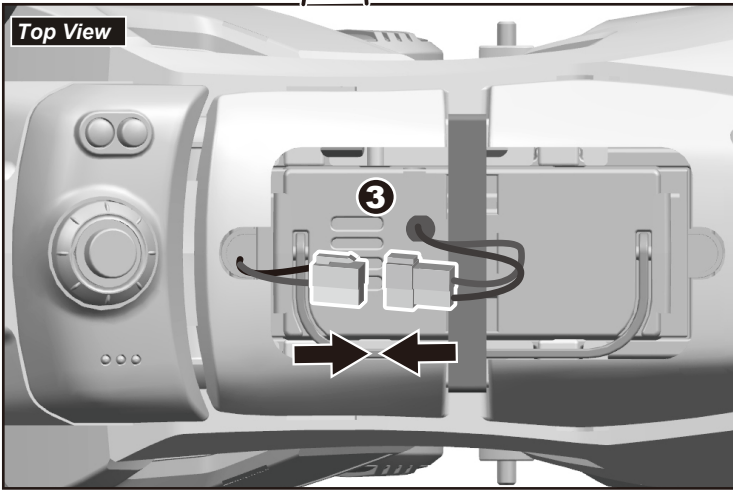
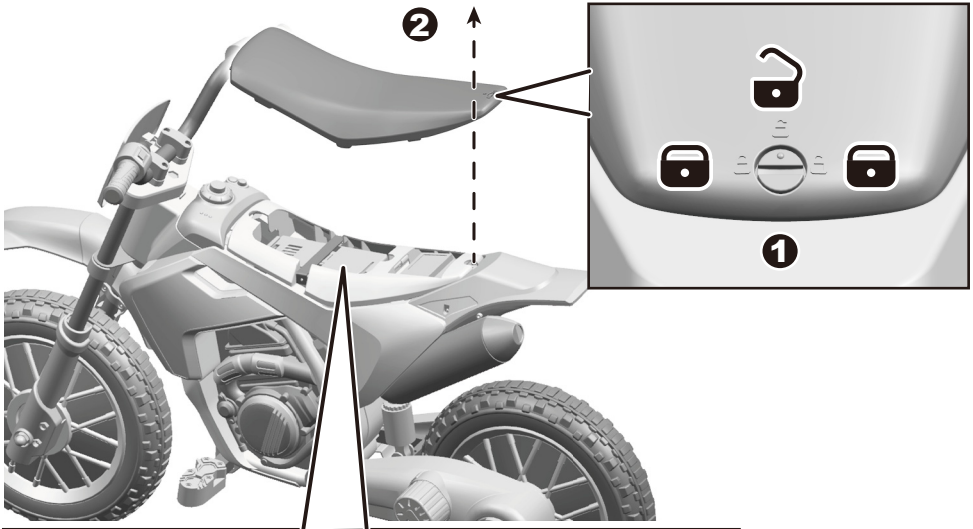

1. Remove the seat.
2. Plug the red connector on the vehicle body into the red connector on the battery.
3. Replace the seat.

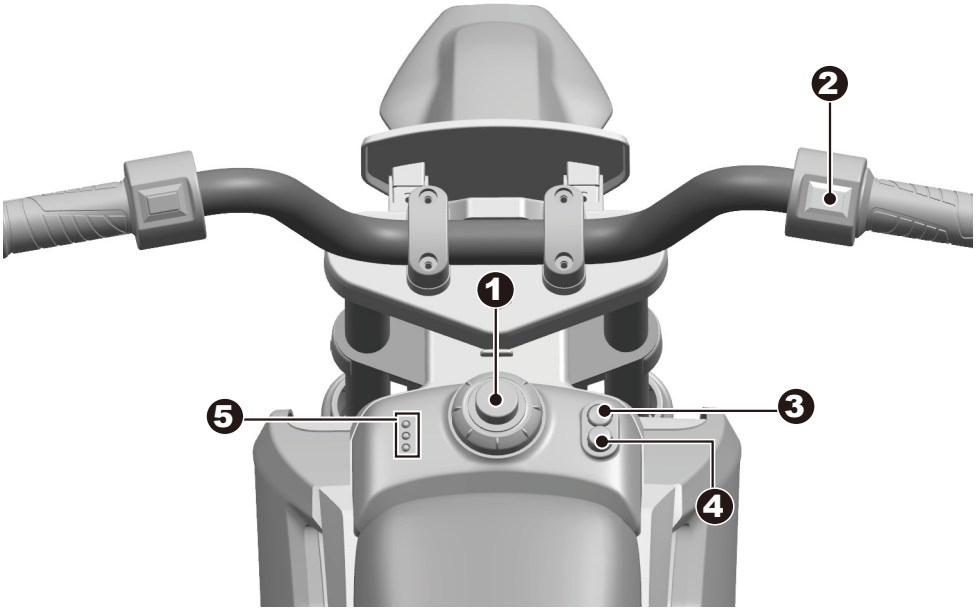

1. **Power button:** Turn the product on and off.
2. **Forward button:** ● To move the product forward, press the button down.
● To brake or slow down, release pressure from the button.
3. **High speed button:** Operate the product to move forward in high speed.
4. **Low speed button:** Operate the product to move forward in low speed.
5. **Power Indicator**

Hint: For the most accurate reading, do not operate the vehicle and ensure the vehicle is stop.

Check the power level of your battery:

- All three lights means the battery is 100% (fully) charged.
- Two lights means the battery is 66% (mostly) charged.
- One light means the battery is 33% charged. We recommend recharging your battery for 8-12 hours.
- No lights means the battery needs charging. Fully charge your battery for 8-12 hours.

⚠ WARNING!**ONLY AN ADULT CAN CHARGE AND RECHARGE THE BATTERY!****⚠ WARNING!**

This product with **Charging Protection**: when charging, all functions will be cut off! Only an adult can charge and recharge the battery!

- The POWER SWITCH must be turned in OFF position when charging.
- Before the first use, you should charge the battery for 4-6 hours. Do not recharge the battery for more than 10 hours to avoid overheating the charger.
- When the vehicle begins to run slowly, recharge the battery.
- After each use or once a month minimum recharge time as 8 to 12 hours, less than 20 hours at most.
- Use the only rechargeable battery and charger supplied with your vehicle. NEVER substitute the battery or the charger with another brand. Using another battery or charger may cause a fire or explosion.
 - **Only use the battery specified by the manufacturer**
 - **Only use the charger specified by the manufacturer.**
- Do not use the battery or charger for any other product.

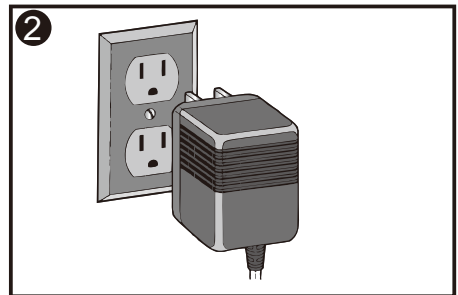
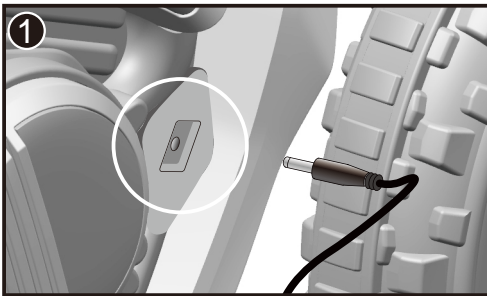

1. Plug the charger port into the input socket. (above the right foot pedal)
2. Plug the charger plug into a wall outlet. The battery will begin charging.

Problem	Possible Cause	Solution
Vehicle does not run	Battery low on power	Recharge battery.
	Thermal fuse has tripped	Reset fuse, see <Fuse>
	Battery connector or wires are loose	Check that the battery connectors are firmly plugged into each other. If wires are loose around the motor contact your distributor please.
	Battery is dead	Replace battery, contact your distributor please.
	Electrical system is damaged	Contact your distributor please.
	Motor is damaged	Contact your distributor please.
Vehicle does not run very long	Battery is under charged	Check that the battery connectors are firmly plugged into each other when recharging
	Battery is old	Replace battery, contact your distributor please.
Vehicle runs sluggishly	Battery low on power	Recharge battery, contact your distributor please.
	Battery is old	Replace battery, contact your distributor please.
	Vehicle is overload	Reduce weight on vehicle.
	Vehicle is being used in harsh conditions	Avoid using vehicle in harsh conditions ,see <Safety>.
Vehicle needs a push to go forward	Poor contact of wires or Connectors	Check that the battery connectors are firmly plugged into each other. If wires are loose around the motor, contact your distributor please.
	“Dead Spot” on motor	A dead spot means the electric power is not being delivered to the terminal connection and the vehicle needs repair. Contact your distributor please.
Difficult shifting from forward to reverse or vice-versa	Attempting to shift while the vehicle is motion	Completely stop the vehicle and shift, see <Use Your New Vehicle>
Loud grinding or clicking noises coming from motor or gear box	Motor or gears are damaged	Contact your distributor please.
Battery will not recharge	Battery connector or adapter connector is loose	Check that the battery connectors are firmly plugged into each other.
	Charger not plugged in	Check that the battery charger is plugged into a working wall outlet.
	Charger is not working	Contact your distributor please.
Charger feels warm when recharging	This is normal and not a cause for concern	

Completely read through this manual and the troubleshooting guide table before calling. If you still need help resolving the problem **Contact your distributor please.**

- It is parents' responsibility to check main parts of the toy before using, must regularly examine for potential hazard, such as the battery, charge, cable or cord, plug, screws are fastening enclosure of other parts and that in the event of such damage, the toy must not be used until that damage had been properly removed.
- Make sure the plastic parts of the vehicle are not cracked or broken.
- Occasionally use a lightweight oil to lubricate moving parts such as wheels.
- Park the vehicle indoors or cover it with a tarp to protect it from wet weather.
- Keep the vehicle away from sources of heat, such as stoves and heaters. Plastic parts may melt.
- Recharge the battery after each use. Only an adult can handle the battery. Recharge the battery at least once a month when the vehicle Raider is not being used.
- Do not wash the vehicle with a hose. Do not wash the vehicle with soap and water. Do not drive the vehicle in rainy or snowy weather. Water will damage the motor, electric system and battery.
- Clean the vehicle with a soft, dry cloth. To restore shine to plastic parts, use a non-wax furniture polish. Do not use car wax. Do not use abrasive cleaners.
- Do not drive the vehicle in loose dirt, sand or fine gravel which could damage the moving parts, motors or the electric system.
- When not using, all the electrical source should be turn off. Turn off the power switch and disconnect the battery connection.

The battery features a thermal fuse with a reset fuse that will automatically trip and cut all power to the vehicle if the motor, electric system or battery is overloaded. The fuse will reset and power will be restored after the unit is turned OFF for 20 seconds and then turned ON again. If the thermal fuse trips repeatedly during normal use, the vehicle may need repair. **Contact your distributor please.**

To avoid losing power, follow these guidelines:

- Do not overload the vehicle.
- Do not tow anything behind the vehicle.
- Do not drive up steep slopes.
- Do not drive into fixed objects, which may cause the wheels to spin, causing the motor to overheat.
- Do not drive in very hot weather, components may overheat.
- Do not allow water or other liquids to come in contact with the battery or other electric components.
- Do not tamper with the electric system. Doing so may create a short, causing the fuse to trip.

Disposal Of Battery



- Your sealed lead-acid battery must be recycled or disposed of in an environmentally sound manner.
- Do not dispose of your lead-acid battery in a fire. The battery may explode or leak.
- Do not dispose of a lead-acid battery in your regular, household trash. The incineration, land filling or mixing of sealed lead-acid batteries with household trash is prohibited by law.

Our products are suitable for ASTM F963; GB6675; EN71 and EN62115 standard.

UK

If you have any questions, please contact our customer care center.

Our contact details are below:



0044-800-240-4004



enquiries@mhstar.co.uk

IMPORTER ADDRESS:
MH STAR UK LTD
Unit 27, Perivale Park,
Horsenden lane South
Perivale, UB6 7RH
MADE IN CHINA

