



IN221000463V02_UK_FR_DE_ES_IT
370-224V70_370-224V90

Honda ATV Electric Ride-on

Installation and operation manual



⚠ CAUTION:

- This package contains small parts – keep away from children.
- Adult assembly required.
- Before giving to children, remove all plastic bags and tyre packaging.
- Protective equipment recommended.
- Not to be used in traffic.
- Keep this manual for future reference.

⚠ WARNING

**ADULT ASSEMBLY
 REQUIRED.**









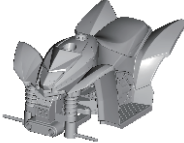
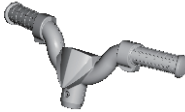

IMPORTANT, RETAIN FOR FUTURE REFERENCE: READ CAREFULLY

ASSEMBLY INSTRUCTION

I . SPECIFICATIONS.

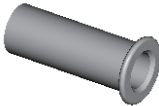
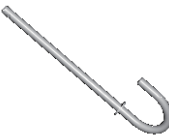
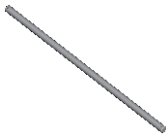
Suitable Ages	18-36 months
Product Dimensions	65.5X38.5X43.5cm
Maximum Weight	25 kgs
Speed	2.8 km/h
Motor	30W
Charger	Input: AC 120V - 240V
	Output:DC6V/500mA
Battery	6V4A
Operating Ambient Temperature	0 - 40°C

II . Components List

1.1 x Body 	2. 1 x Handle 	3. 2 x Front wheel 	4. 2 x Rear wheel 
5. 4 x Wheel cover 	6. 1 x Bumper 	7. 1 x Motor 	8. 1 x Spacer 
9. 1 x J stick 	10. 1 x Axle 	11. 5 x Cotter pin (one replacement) 	12. 7 x Washer (one replacement) 
13. 1 x Charger 			

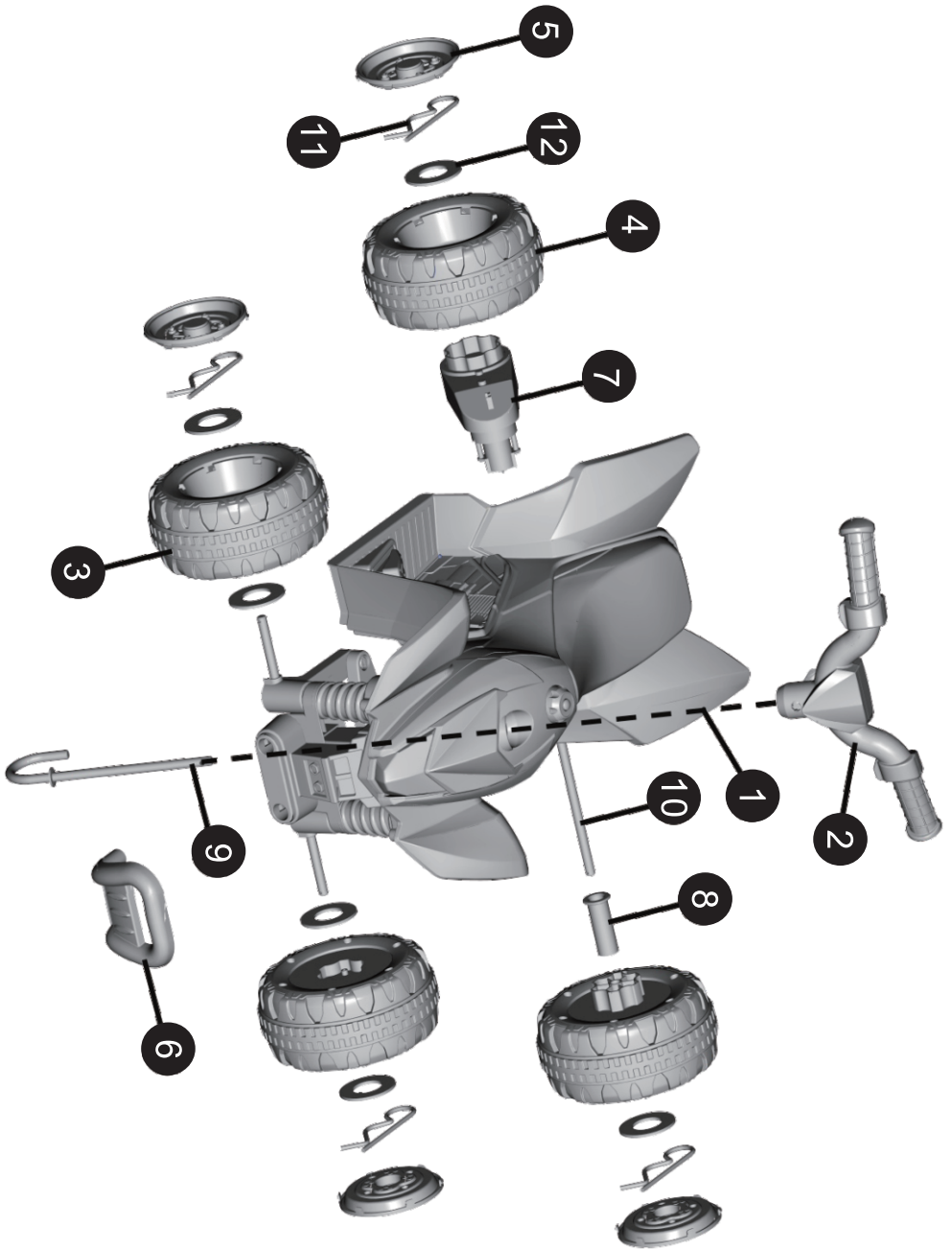

III. Assembly Instructions

< 1 >

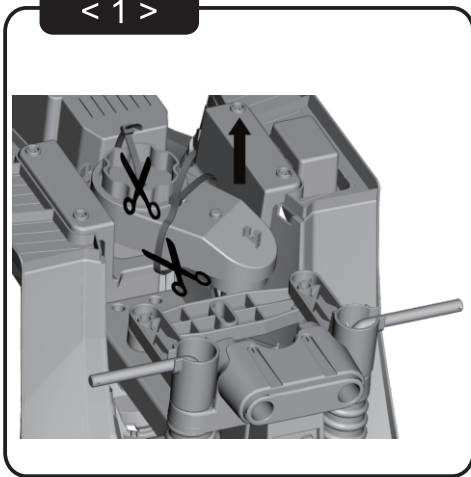

< 2 >

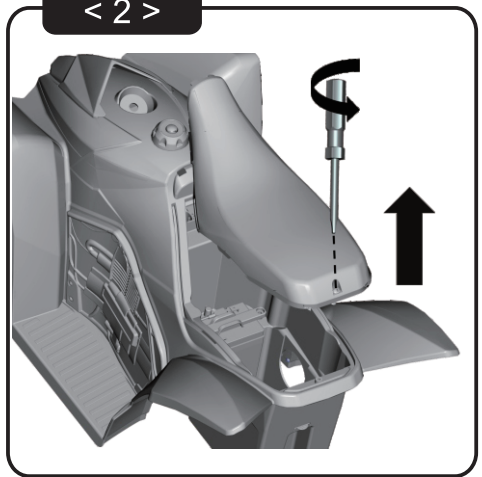

Please remove the motor and assemble it on the car
(Step 4 How to assemble)

< 3 >

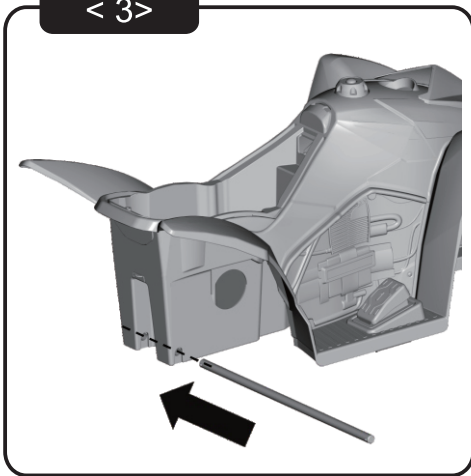

< 4 >

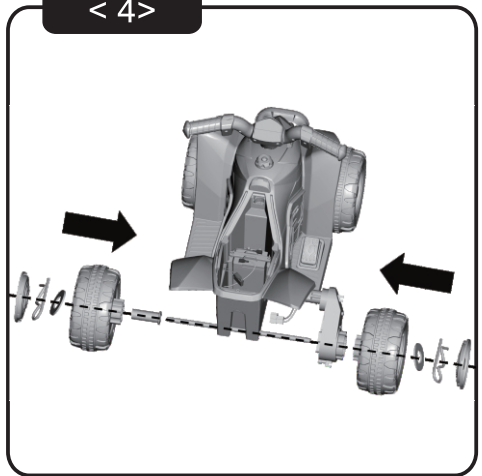

< 5 >

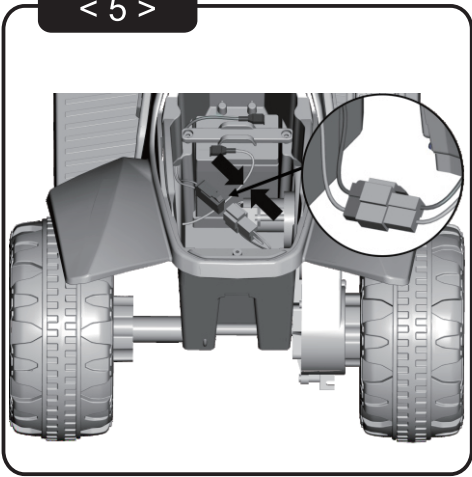

< 6 >

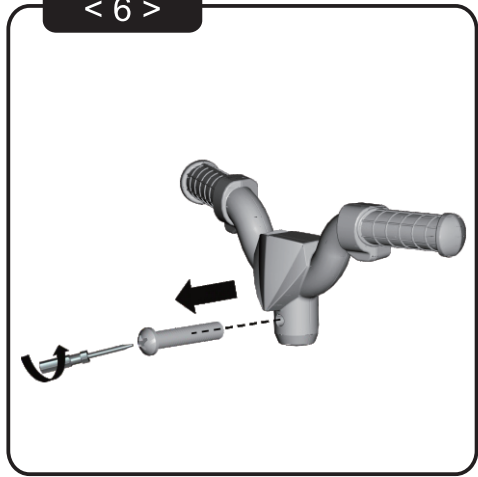

< 7 >

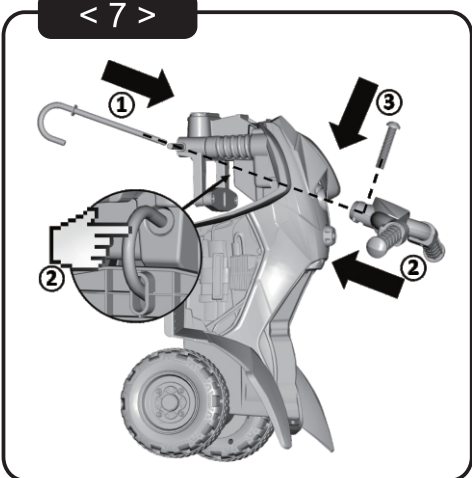

< 8 >

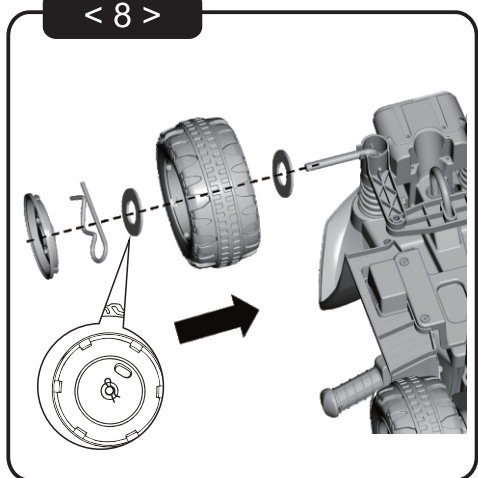

< 9 >

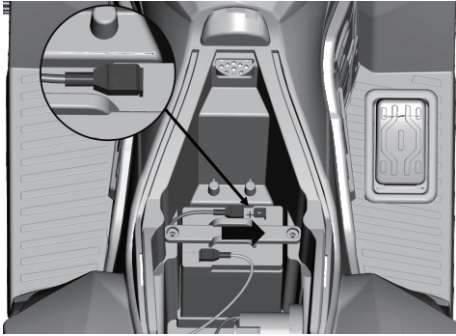

< 10 >

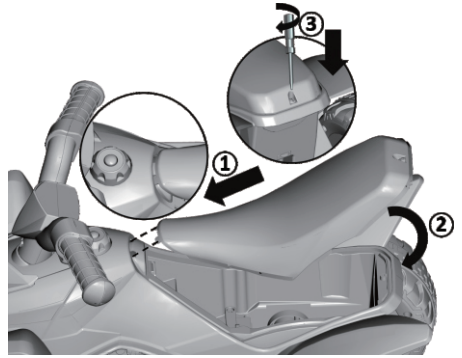

< 11 >

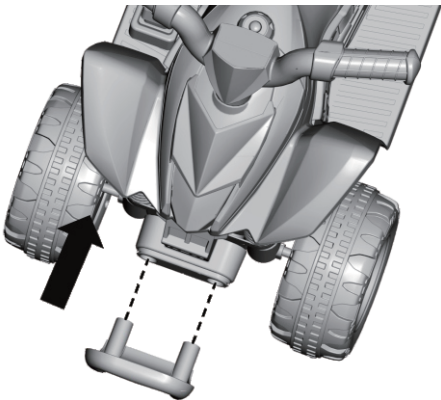

IV. Function and Operation

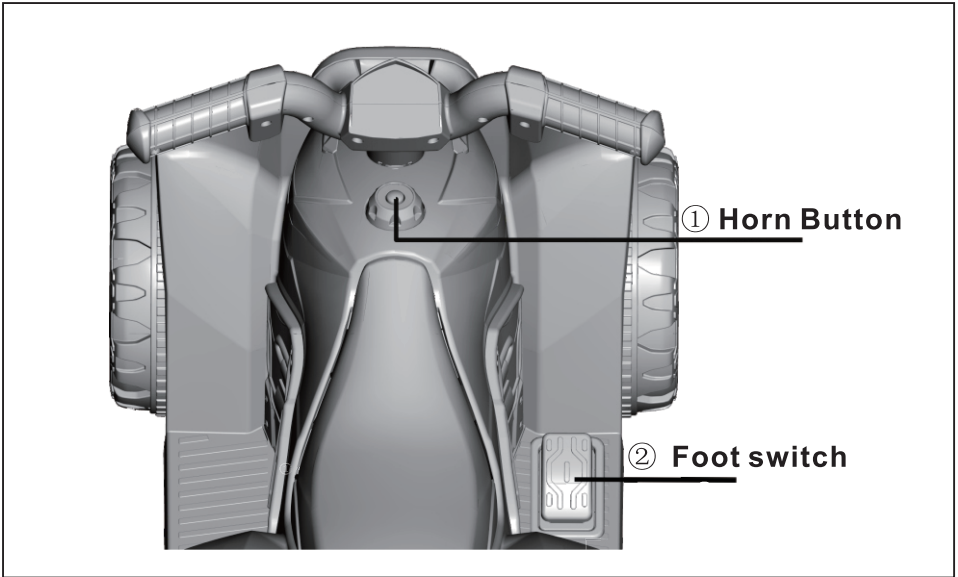

V. Battery and charger operation guide

1. The charging socket is located at the rear.
2. Only use the provided or recommended battery and charger.
3. Do not play with the charger and battery.
4. Batteries must only be charged by adults.
5. The battery must be fully charged before first use. Charge for 9-10 hours – do not exceed 15 hours.
6. When charging, it is normal for charger and battery to be warm.

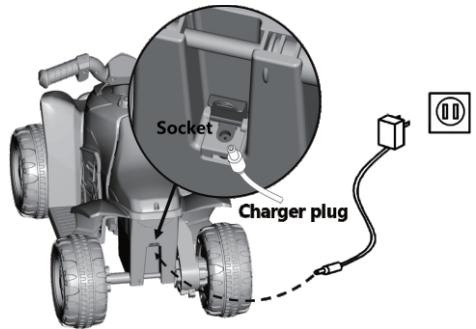

VI.WARNING.

1.Battery warning:

- 1) When storing the car for a long time, fully charge the battery, then turn off the power. The battery should be recharged once every other month – minimising the risk of shortening its lifespan.
- 2) When installing the battery, the positive and negative poles must be correctly connected. Short circuiting of positive and negative poles could damage the product.
- 3) Only adults should change batteries.
- 4) Recharging batteries must be done by adults.
- 5) Non-rechargeable batteries cannot be charged.
- 6) Before recharging chargeable batteries, ensure they are removed from the remote control.
- 7) Do not mix different types of batteries.
- 8) Do not mix old and new batteries.
- 9) When storing the car for a long time, ensure the batteries are removed.
- 10) Over-used batteries should be removed.

2.Product warning

- 1) Pre-assembled parts can be sharp – product assembly must be done by an adult. Keep parts away from small children.
- 2) To avoid suffocation, keep plastic bags away from children. Dispose of all bags immediately.
- 3) When children ride this product, adult supervision is required.
- 4) This car is to be driven on a flat and even ground. Do not drive on public roads, steep hills or near swimming pools.
- 5) Wear shoes when using this product. Take protective measures, such as fastening the seatbelt and wearing a helmet, gloves, kneepads etc.
- 6) Regularly check the battery, charger, wire, plug, casing and other parts. If there are any damages, do not use the product until it has been repaired.
- 7) This product can fit one child at a time. The maximum load is 30kg – do not exceed this limit.
- 8) Keep this product away from open flames.
- 9) Keep is manual for future reference.

 **WARNING**

- Adult supervision required – minimising the risk of injury.
- Do not use on roads, near motor vehicles, slopes, swimming pools or areas where there is water.
- Wear shoes when using this ride-on.
- Can only be used by one child at a time.
- Before this product is assembled, keep it away from children. There could be small and sharp parts, which could be dangerous.
- This product must be assembled by an adult.

 **WARNING**

Do not mix alkaline, standard (carbon-zinc) or rechargeable (nickel-cadmium) batteries.

 **WARNING**

Protective equipment should be worn. Do not ride in traffic.



IN221000463V02_UK_FR_DE_ES_IT
370-224V70_370-224V90

Quad électrique Honda pour enfants Manuel d'installation et d'utilisation



⚠ ATTENTION :

- Ce paquet contient de petites pièces - tenir hors de portée des enfants.
- Assemblage par un adulte requis.
- Avant de remettre le jouet aux enfants, retirez tous les sacs plastiques et emballages des pneus.
- Équipement de protection recommandé.
- Ne pas utiliser dans la circulation.
- Conservez ce manuel pour référence future.

⚠ ATTENTION :

ASSEMBLAGE PAR UN ADULTE REQUIS.













IMPORTANT - CONSERVEZ CES INFORMATIONS POUR VOTRE CONSULTATION ULTÉRIEURE: LISEZ ATTENTIVEMENT

INSTRUCTIONS D'ASSEMBLAGE

I. SPÉCIFICATIONS

Âges recommandés :	18-36 mois
Dimensions du produit	65,5X38,5X43,5cm
Poids maximum	25kgs
Vitesse	2,8 km/h
Moteur	30W
Chargeur	Entrée : AC 120V-240V
	Sortie : DC6V/500mA
Batterie	6V4A
Température ambiante de fonctionnement	0-40°C

II. Liste des parties

1.1 1 X Corps 	2. 1 X Guidon 	3. 2 X Roue avant 	4. 2 X Roue arrière 
5. 4 X Enjoliveur de roue 	6. 1 X Pare-chocs 	7. 1 X Moteur L'emplacement est en dessous du véhicule. 	8. 1 X Entretoise 
9. 1 X Bâton en J 	10. 1. Essieu 	11. 5 X Goupille fendue (une de rechange) 	12. 7 X Rondelle (une de rechange) 
13. 1 X Chargeur 			

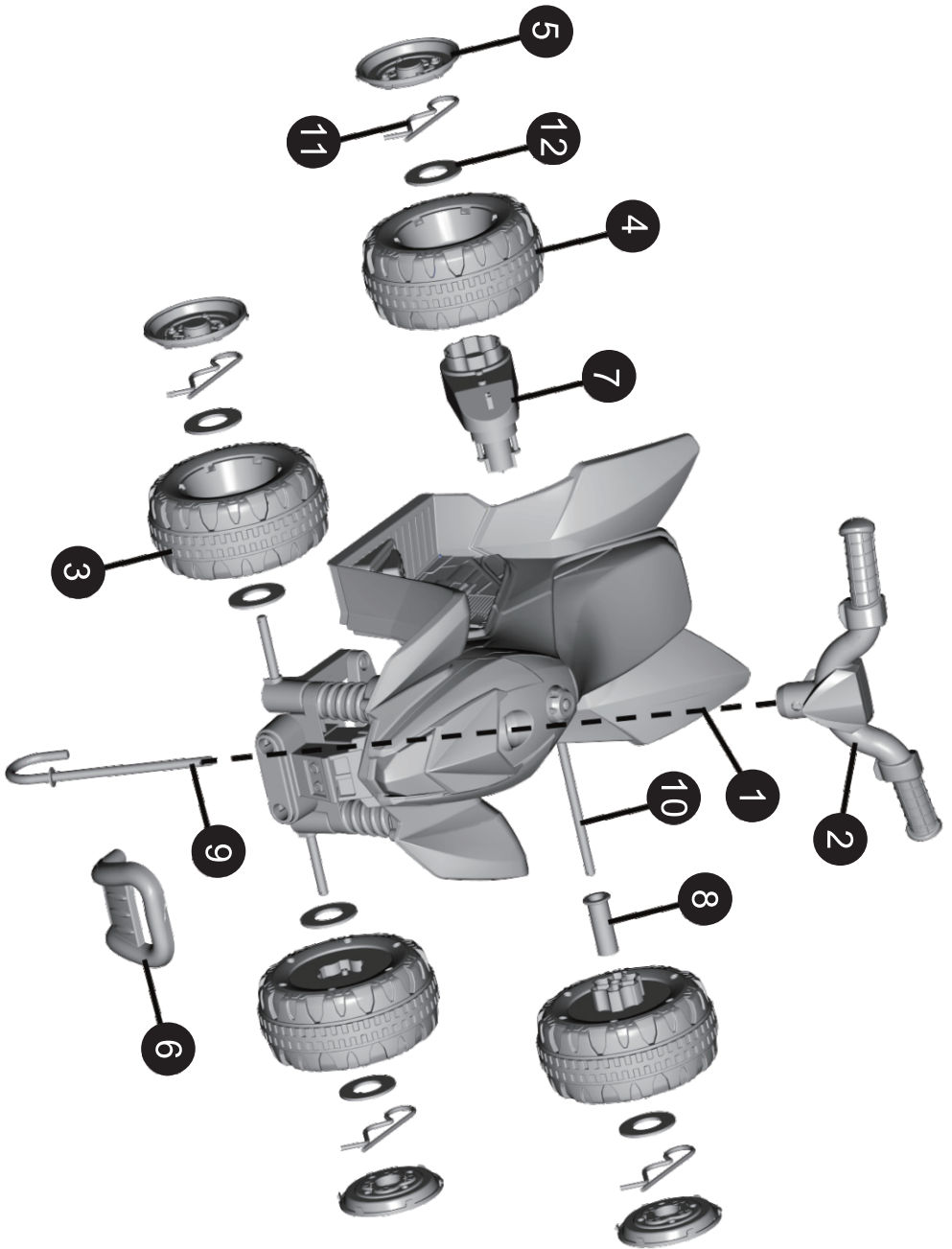

III. INSTRUCTIONS D'ASSEMBLAGE

< 1 >

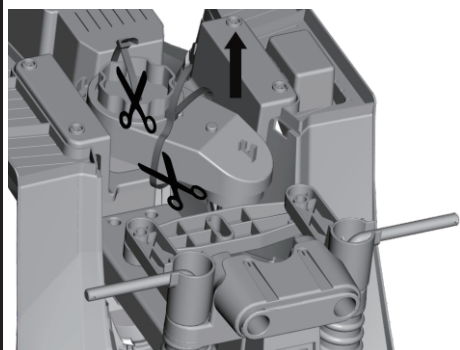

< 2 >



Veillez retirer le moteur et l'assembler sur la voiture (Étape 4 Comment assembler)

< 3 >

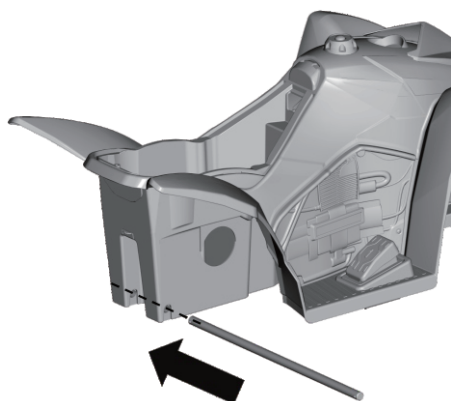

< 4 >

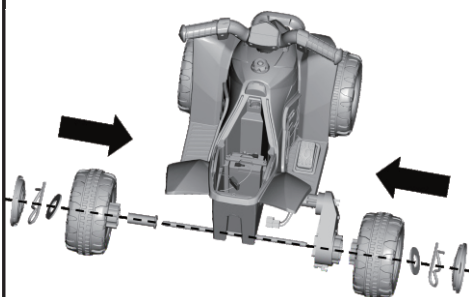

< 5 >

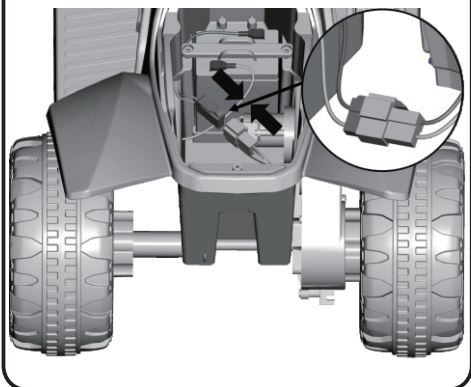

< 6 >

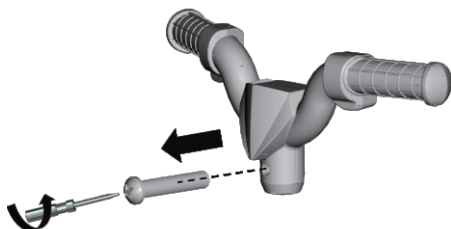

< 7 >

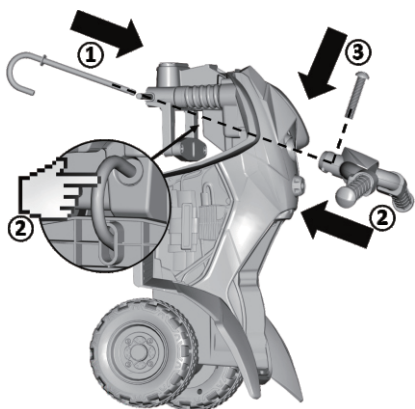

< 8 >

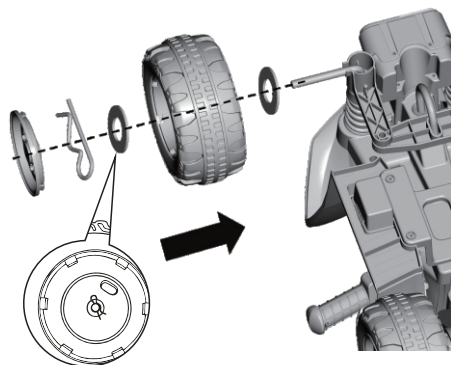

< 9 >

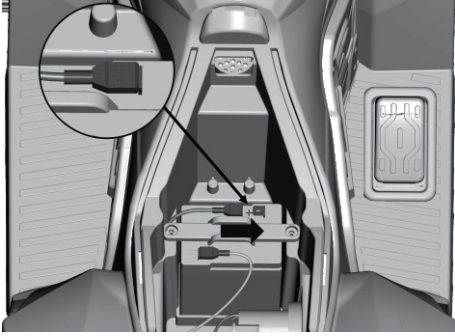

< 10 >

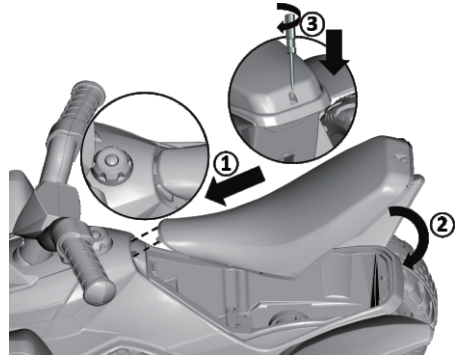

< 11 >

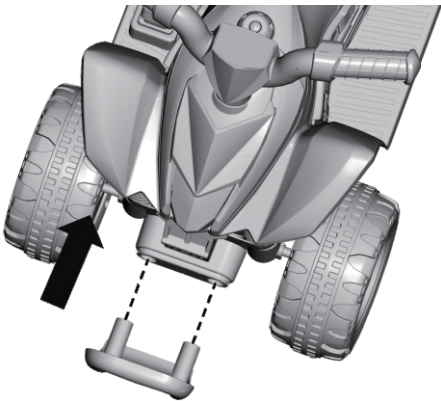

IV.Fonction et utilisation

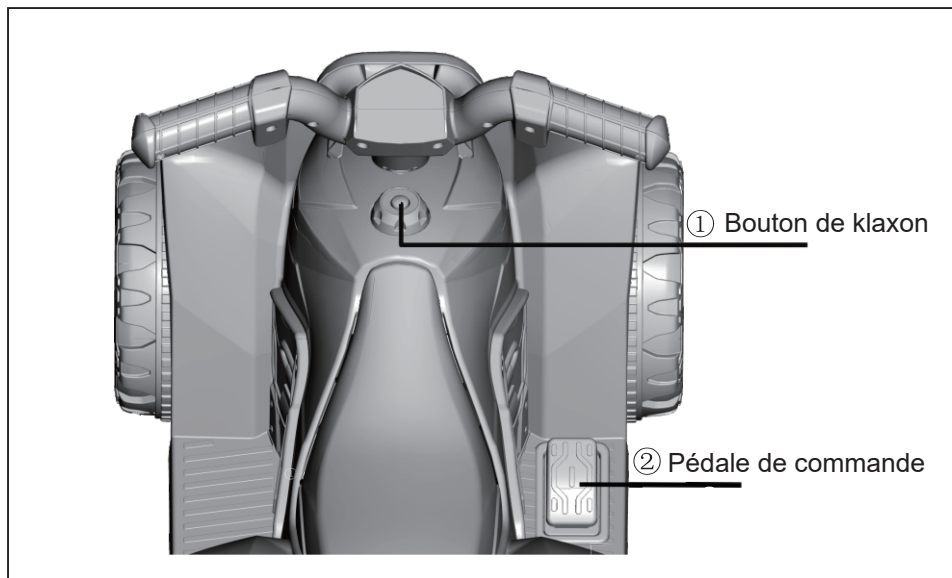

V.Guide d'utilisation de la batterie et du chargeur

1. La prise de charge se trouve à l'arrière.
2. Utilisez uniquement la batterie et le chargeur fournis ou recommandés.
3. Ne jouez pas avec le chargeur et la batterie.
4. La batterie doit être chargée uniquement par des adultes.
5. La batterie doit être complètement chargée avant la première utilisation. Chargez pendant 9 à 10 heures - ne dépassez pas 15 heures.
6. Lors de la charge, il est normal que le chargeur et la batterie soient chauds.

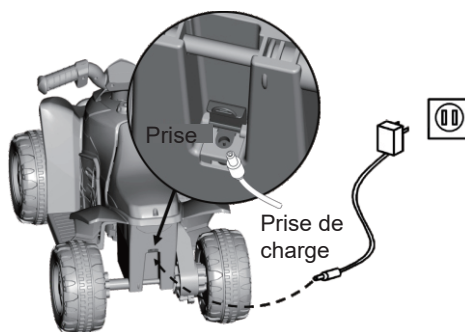

VI. AVERTISSEMENT !

1. Avertissement concernant la batterie :

- 1) Lorsque vous stockez la voiture pendant une longue période, chargez complètement la batterie, puis éteignez l'alimentation. La batterie doit être rechargée tous les deux mois - minimisant le risque de réduction de sa durée de vie.
- 2) Lors de l'installation de la batterie, les pôles positif et négatif doivent être correctement connectés. Le court-circuit des pôles positif et négatif peut endommager le produit.
- 3) Seuls les adultes doivent changer les batteries.
- 4) La recharge des batteries doit être effectuée par des adultes.
- 5) Les batteries non rechargeables ne peuvent pas être chargées.
- 6) Avant de recharger les batteries rechargeables, assurez-vous qu'elles sont retirées de la télécommande.
- 7) Ne mélangez pas différents types de batteries.
- 8) Ne pas mélanger des piles usagées et des piles neuves.
- 9) Lorsque vous rangez la voiture pendant une longue période, assurez-vous que les batteries sont retirées.
- 10) Les batteries usagées doivent être retirées.

2. Avertissement concernant le produit

- 1) Les pièces pré-assemblées peuvent être tranchantes - l'assemblage du produit doit être effectué par un adulte. Gardez les pièces hors de portée des petits enfants.
- 2) Pour éviter l'asphyxie, gardez les sacs plastiques loin des enfants. Disposez immédiatement de tous les sacs.
- 3) Lorsque les enfants utilisent ce produit, la surveillance d'un adulte est requise.
- 4) Cette voiture doit être conduite sur un sol plat et régulier. Ne pas conduire sur des voies publiques, des pentes abruptes ou près de piscines.
- 5) Portez des chaussures lors de l'utilisation de ce produit. Prenez des mesures de protection, telles que le bouclage de la ceinture de sécurité et le port d'un casque, de gants, de genouillères, etc.
- 6) Vérifiez régulièrement la batterie, le chargeur, le câble, la prise, le boîtier et les autres parties. Si des dommages sont constatés, n'utilisez pas le produit avant qu'il ait été réparé.
- 7) Ce produit peut accueillir un enfant à la fois. La charge maximale est de 25kg - ne dépassez pas cette limite.
- 8) Gardez ce produit loin des flammes ouvertes.
- 9) Conservez ce manuel pour référence future.

 **ATTENTION**

- Une surveillance adulte est requise - minimisant le risque de blessure.
- Ne pas utiliser sur les routes, près des véhicules motorisés, des pentes, des piscines ou des zones où il y a de l'eau.
- Portez des chaussures lors de l'utilisation de ce véhicule pour enfants.
- Peut uniquement être utilisé par un enfant à la fois.
- Avant que ce produit soit assemblé, gardez-le loin des enfants. Il pourrait y avoir des petites pièces et tranchantes, ce qui pourrait être dangereux.
- Ce produit doit être assemblé par un adulte.

 **ATTENTION**

Ne mélangez pas les batteries alcalines, standard (carbone-zinc) ou rechargeables (nickel-cadmium).

 **ATTENTION**

Un équipement de protection doit être porté. Ne pas utiliser dans la circulation.



18-36
Monate

IN221000463V02_UK_FR_DE_ES_IT
370-224V70_370-224V90

Honda ATV Elektrofahrzeug

Montage- Und Betriebsanleitung



CE



VORSICHT:

- Diese Verpackung enthält Kleinteile.
- Montage durch einen Erwachsenen erforderlich.
- Entfernen Sie alle Plastiktüten und Reifenverpackungen, bevor Sie es an Kinder weitergeben.
- Schutzausrüstung empfohlen.
- Nicht für den Einsatz im Straßenverkehr geeignet.
- Bewahren Sie dieses Handbuch zum späteren Nachschlagen auf.



ACHTUNG

**MONTAGE DURCH
EINEN
ERWACHSENEN
ERFORDERLICH.**

**WICHTIG, FÜR DIE SPÄTERE VERWENDUNG AUFBEWAHREN:
SORGFÄLTIG DURCHLESEN**

MONTAGEANWEISUNGEN

I . SPEZIFIKATIONEN.

Geeignetes Alter	18-36 Monate
Produktabmessungen	65,5 x 38,5 x 43,5 cm
Maximales Gewicht	25 kg
Geschwindigkeit	2,8 km/h
Motor	30 W
Ladegerät	Eingang: AC 120 V bis 240 V
	Ausgang: DC 6 V/500 mA
Akku	6 V 4 A
Betriebsumgebungstemperatur	0-40

II . Liste der Bauteile

1.1 x Gehäuse 	2.1 x Handgriff 	3. 2 x Vorderräder 	4. 2 x Hinterräder 
5.4 x Radkappen 	6.1 x Stoßstange 	7.1 x Motor 	8.1 x Abstandhalter 
9.1 x J-Stock 	10.1 x Achse 	11.5 x Splinte (ein Ersatzteil) 	12. 7 x Unterlegscheiben (ein Ersatzteil) 
13. 1 x Ladegerät 			

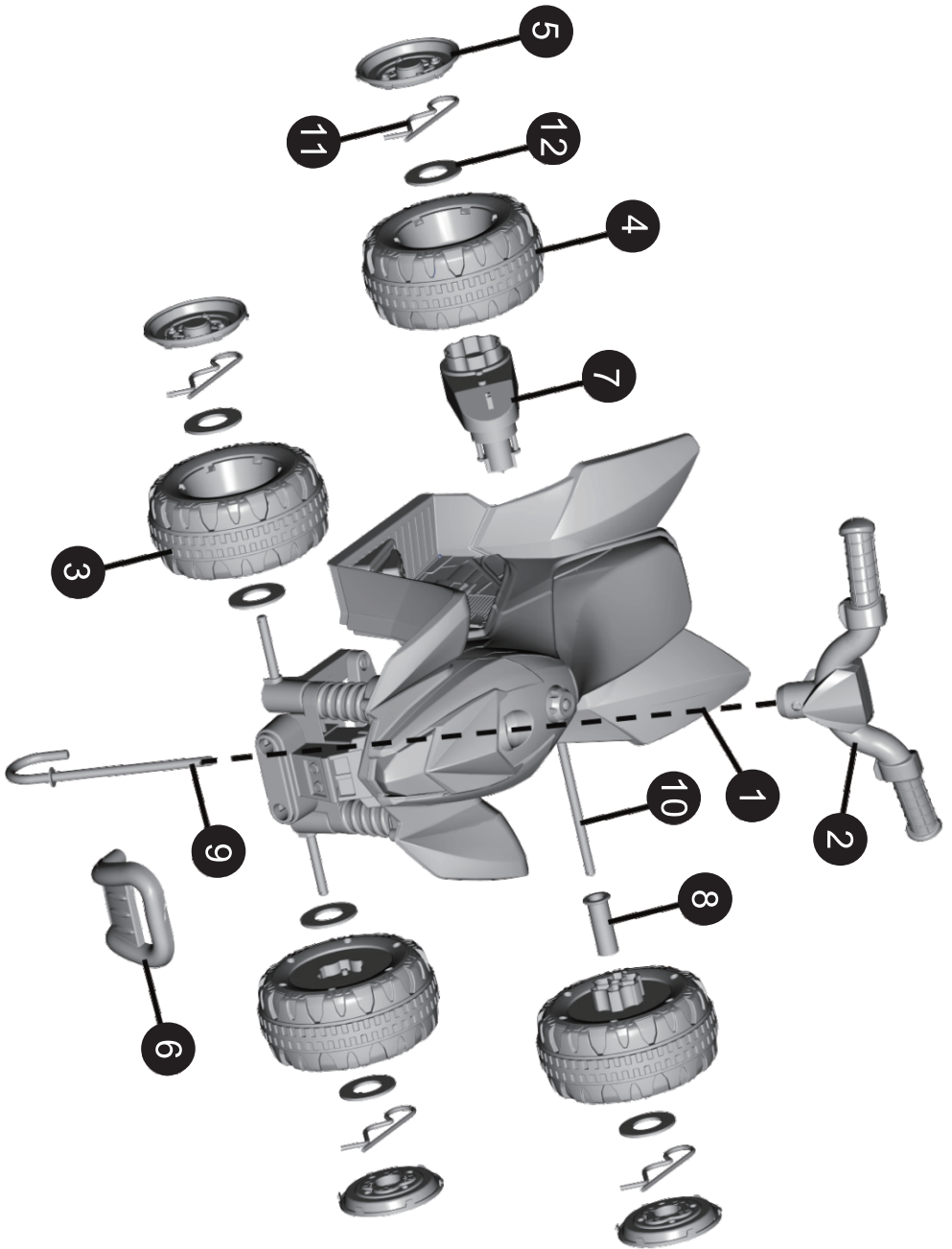

III. Montageanweisungen

< 1 >

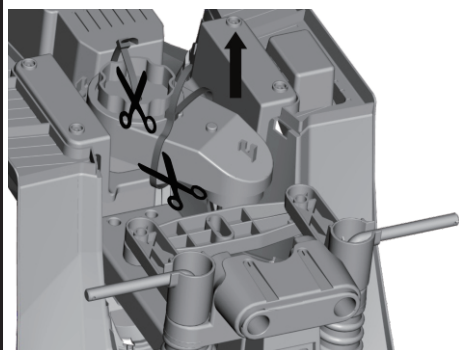

< 2 >

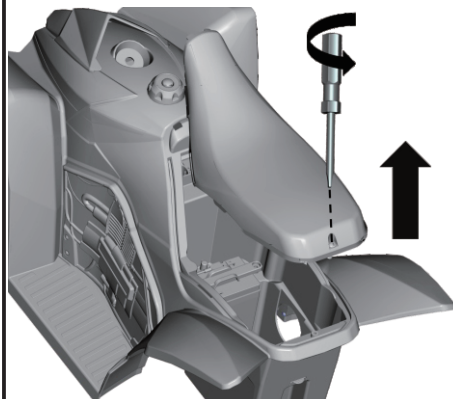

Veillez retirer le moteur et l'assembler sur la voiture (Étape 4 Comment assembler)

< 3 >

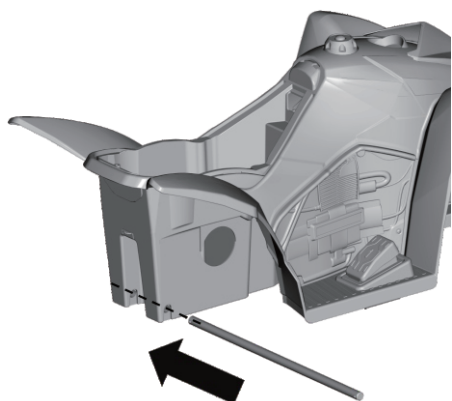

< 4 >

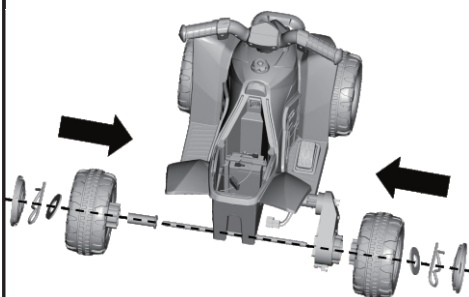

< 5 >

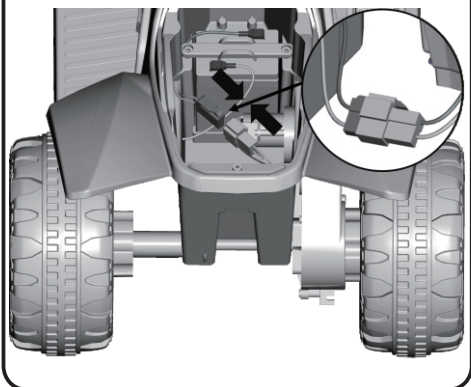

< 6 >

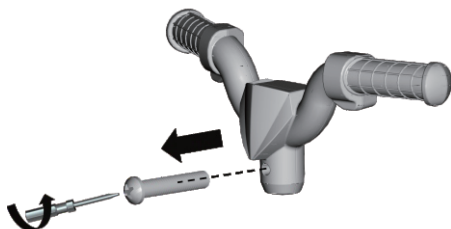

< 7 >

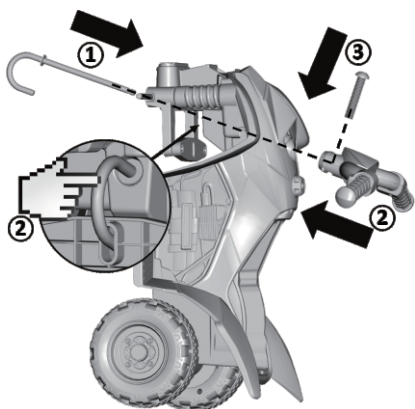

< 8 >

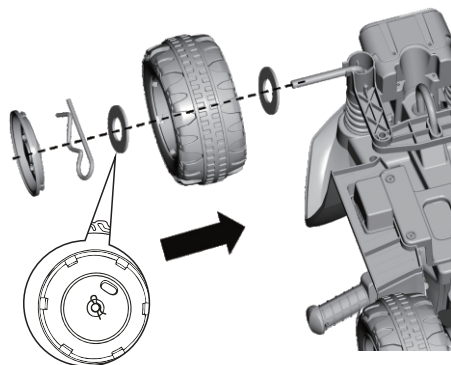

< 9 >

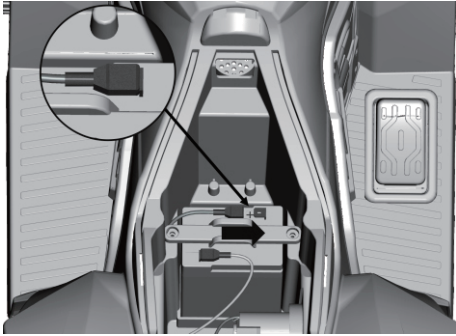

< 10 >

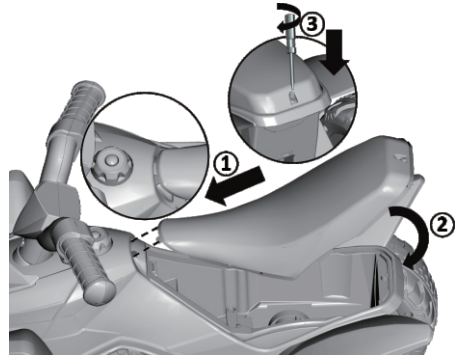

< 11 >

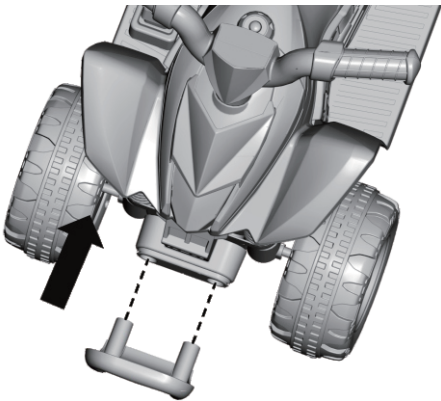

IV. Funktion und Betrieb

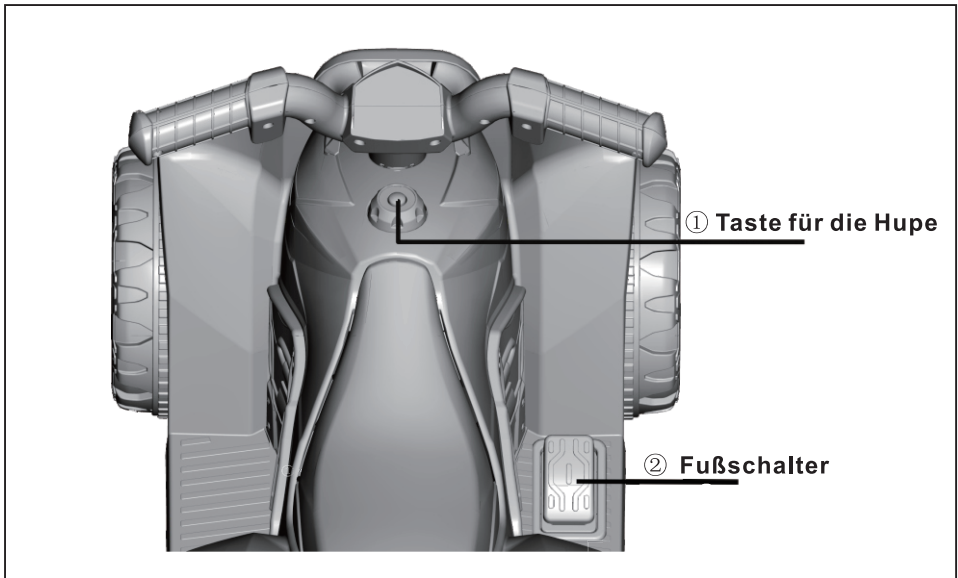

V. Bedienungsanleitung für Akku und Ladegerät

1. Die Ladebuchse befindet sich im unteren Teil des Autositzes.
2. Verwenden Sie nur das mitgelieferte oder empfohlene Ladegerät und den Akku.
3. Spielen Sie nicht mit dem Ladegerät und dem Akku.
4. Nur Erwachsene sollten den Akku aufladen.
5. Vergewissern Sie sich vor der ersten Verwendung, dass der Akku vollständig aufgeladen ist. Die Ladezeit beträgt 9-10 Stunden – 15 Stunden sollten nicht überschritten werden.
6. Beim Aufladen ist es normal, dass der Akku und das Ladegerät warm werden.

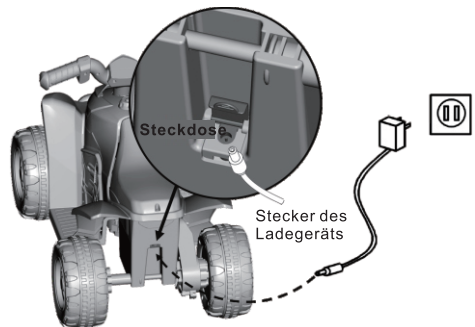

VI. Warnung.

1. Akkuwarnung:

- 1) Wenn Sie das Fahrzeug über einen längeren Zeitraum lagern, laden Sie den Akku vollständig auf und schalten Sie das Gerät dann aus. Der Akku sollte alle zwei Monate aufgeladen werden, um das Risiko einer Verkürzung seiner Nutzungsdauer zu minimieren.

- 2) Beim Einbau des Akkus müssen die Plus- und Minuspole richtig angeschlossen werden. Ein Kurzschluss der Plus- und Minuspole kann das Gerät beschädigen.
- 3) Der Batteriewechsel sollte nur von Erwachsenen vorgenommen werden.
- 4) Das Aufladen der Batterien darf nur von Erwachsenen durchgeführt werden.
- 5) Nicht wiederaufladbare Batterien können nicht aufgeladen werden.
- 6) Vergewissern Sie sich vor dem Aufladen von wiederaufladbaren Batterien, dass diese aus der Fernbedienung entfernt wurden.
- 7) Mischen Sie nicht verschiedene Batterietypen.
- 8) Vermischen Sie alte und neue Batterien nicht.
- 9) Wenn Sie das Fahrzeug für längere Zeit einlagern, stellen Sie sicher, dass die Batterien entfernt werden.
- 10) Überbeanspruchte Batterien sollten entfernt werden.

2. Produktwarnung

- 1) Vormontierte Teile können scharfkantig sein – der Zusammenbau des Produkts muss von einem Erwachsenen ausgeführt werden. Halten Sie die Teile von Kleinkindern fern.
- 2) Um Erstickungsgefahr zu vermeiden, halten Sie Plastiktüten von Kindern fern. Entsorgen Sie alle Tüten sofort.
- 3) Wenn Kinder mit diesem Produkt fahren, ist die Aufsicht eines Erwachsenen erforderlich.
- 4) Dieses Fahrzeug darf nur auf flachem und ebenem Boden gefahren werden. Fahren Sie nicht auf öffentlichen Straßen, an steilen Hängen oder in der Nähe von Schwimmbädern.
- 5) Tragen Sie Schuhe, wenn Sie dieses Produkt benutzen. Treffen Sie Schutzmaßnahmen, wie das Anlegen des Sicherheitsgurtes und das Tragen eines Helms, von Handschuhen, Knieschonern usw.
- 6) Überprüfen Sie regelmäßig Akku, Ladegerät, Kabel, Stecker, Gehäuse und andere Teile. Verwenden Sie das Produkt im Falle von Schäden nicht, bis es repariert ist.
- 7) Dieses Produkt ist für jeweils ein Kind geeignet. Die maximale Belastung beträgt 30 kg – überschreiten Sie diese Grenze nicht.
- 8) Halten Sie dieses Produkt von offenen Flammen fern.
- 9) Bewahren Sie dieses Handbuch zum späteren Nachschlagen auf.

ACHTUNG

- Die Beaufsichtigung durch einen Erwachsenen ist erforderlich, um das Verletzungsrisiko zu minimieren.
- Verwenden Sie es nicht auf Straßen, in der Nähe von Kraftfahrzeugen, an Hängen, in Schwimmbädern oder an Orten, an denen sich Wasser befindet.
- Tragen Sie Schuhe, wenn Sie dieses Elektrofahrzeug verwenden.
- Kann jeweils nur von einem Kind benutzt werden.
- Halten Sie dieses Produkt von Kindern fern, bevor es zusammengebaut wird. Es könnten kleine und scharfe Teile vorhanden sein, die gefährlich sein könnten.
- Dieses Produkt muss von einem Erwachsenen zusammengebaut werden.
- Verwenden Sie dieses Produkt immer mit Vorsicht.

ACHTUNG

Mischen Sie keine Alkali-, Standard- (Kohle-Zink) oder wiederaufladbaren (Nickel-Cadmium) Batterien.

ACHTUNG

Es sollte eine Schutzausrüstung getragen werden. Fahren Sie nicht im Straßenverkehr.



IN221000463V02_UK_FR_DE_ES_IT
370-224V70_370-224V90

Honda ATV Ride-on Eléctrico

Manual de instalación y operación



PRECAUCIÓN:

- Este paquete contiene piezas pequeñas.
- El montaje debe ser realizado por los adultos.
- Antes de dárselo a los niños, retire todas las bolsas de plástico y el embalaje de los neumáticos.
- Se recomienda usar equipo de protección.
- No debe ser utilizado en el tráfico.
- Guarde este manual bien para las referencias futuras.



ADVERTENCIA

EL MONTAJE DEBE SER REALIZADO POR LOS ADULTOS.



IMPORTANTE, GUARDE PARA LAS REFERENCIAS FUTURAS: LEA CUIDADOSAMENTE

INSTRUCCIONES DE MONTAJE

I. ESPECIFICACIONES

Edades adecuadas	18-36 meses
Dimensiones del producto	65,5*38,5*43,5cm
Peso máximo	25 kilos
Velocidad	2,8km/h
Motor	30w
Cargador	Entrada: CA120V -240V
	Salida: CC6V/500MA
Batería	6V4A
Temperatura ambiente de operación	0- 40°C

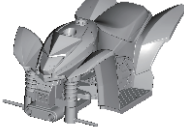
II. Lista de componentes

1. 1*Carrocería del automóvil 	2. 1*Manillar 	3. 2*Rueda frontal 	4.2*Rueda trasera 
5.4*Cubierta de rueda 	6. 1*Parachoque 	7.1* Motor 	8.1*Espaciador 
9.1*Palo en forma de J 	10. 1*Eje 	11.5*Pasador de chaveta (una pieza de repuesto) 	12.7*Arandela (una pieza de repuesto) 
13. 1* Cargador 			

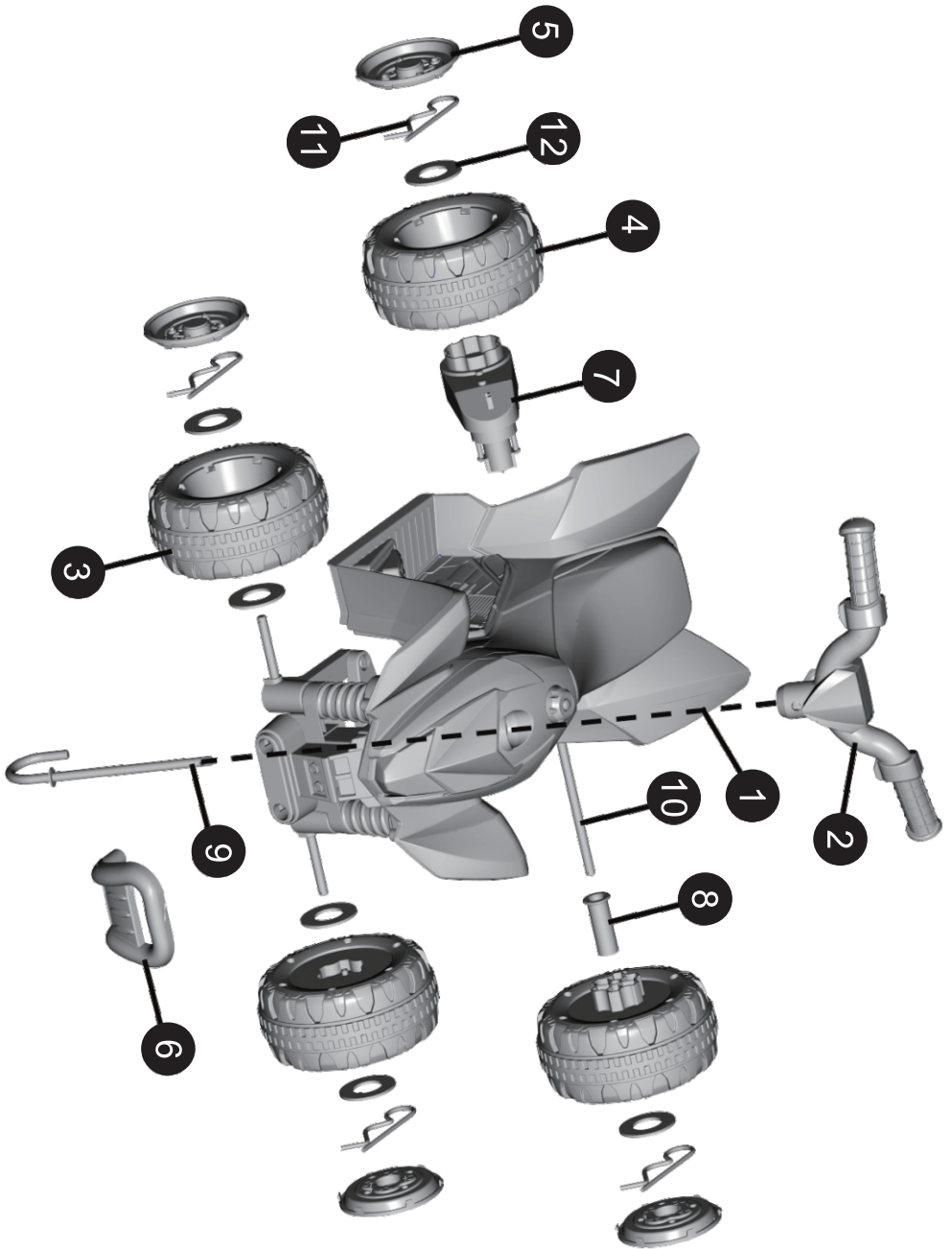

III. Instrucciones de montaje

< 1 >

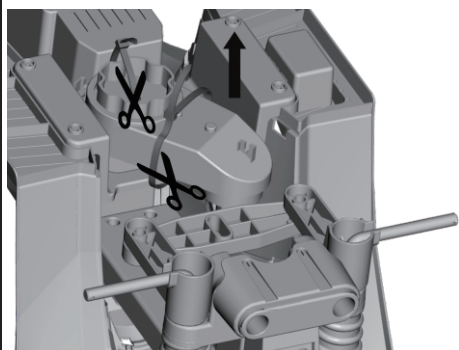

< 2 >

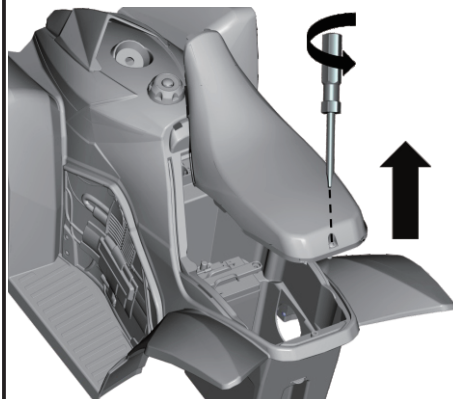

Por favor, retire el motor y ensámblelo en el coche.
(Paso 4 Cómo ensamblar)

< 3 >

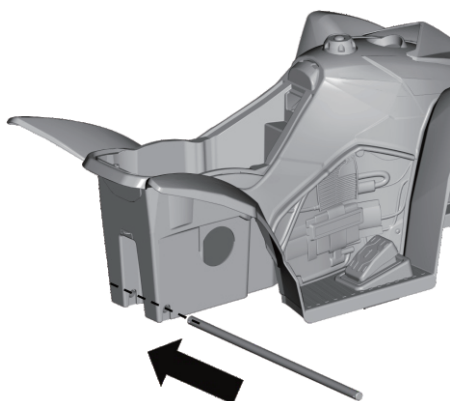

< 4 >

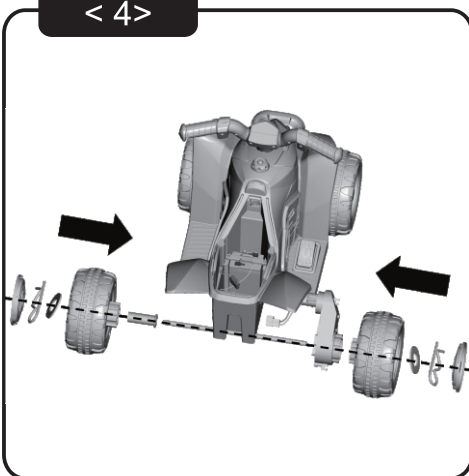

< 5 >

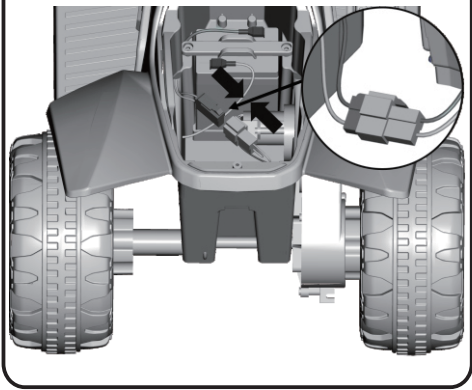

< 6 >

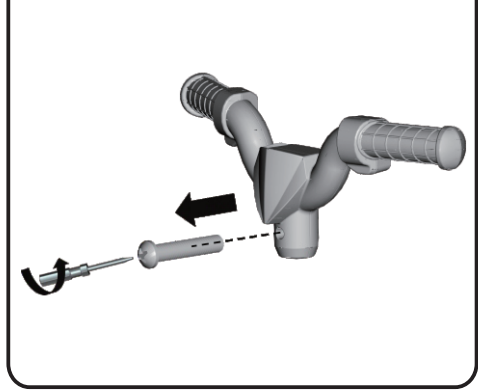

< 7 >

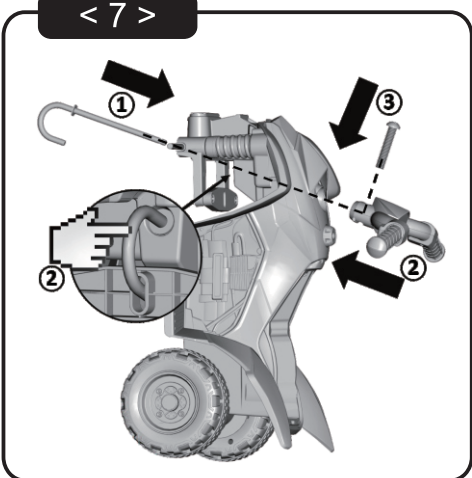

< 8 >

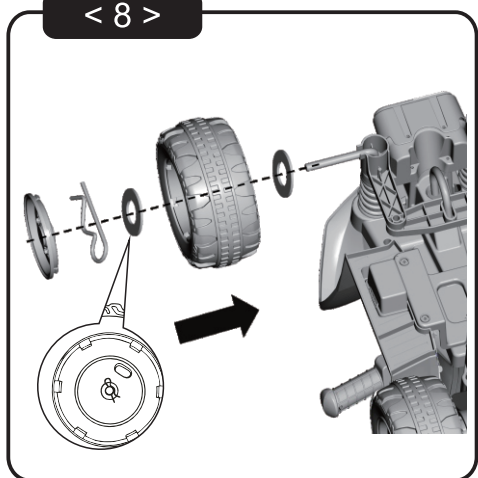

< 9 >

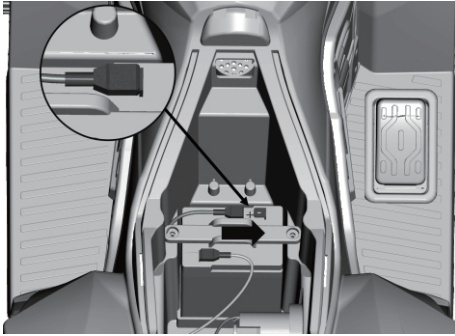

< 10 >

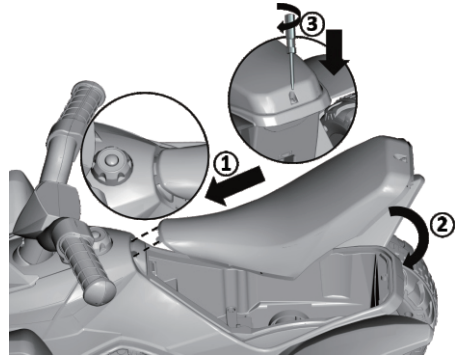

< 11 >

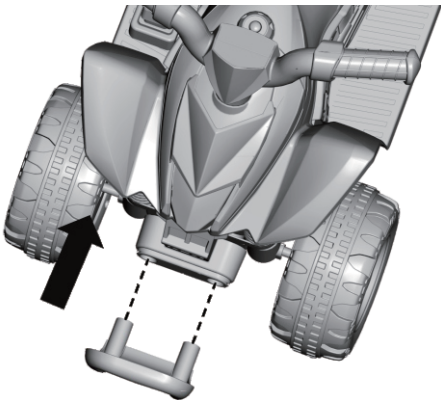

IV. Función y Operación

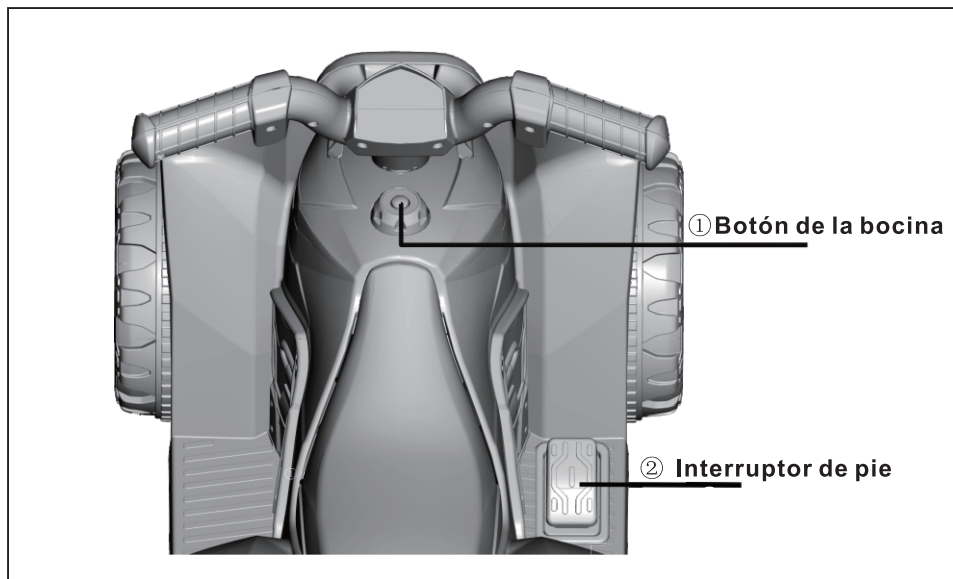

V. Guía de operación de la batería y el cargador

1. La toma de carga está en la parte inferior del asiento del automóvil.
2. Solo utilice el cargador y la batería proporcionados o recomendados.
3. No juegue con el cargador y la batería.
4. Solo los adultos pueden cargar la batería.
5. Antes del primer uso, asegúrese de que la batería esté cargada por completo. El tiempo de carga puede ser de 9 a 10 horas; pero no más de 15 horas.
6. Es normal que la batería y el cargador se calienten durante la carga.

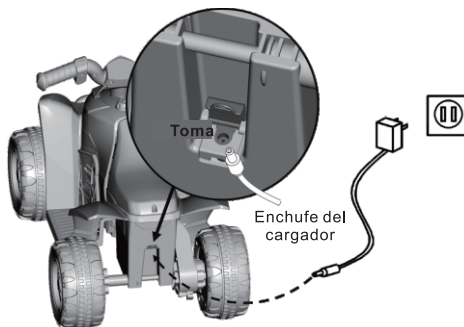

VI. Advertencia

1. Advertencia de batería:

- 1) Después de almacenar el automóvil durante largo plazo, cargue la batería por completo, y luego desconecte la alimentación. Debe recargar la batería una vez cada dos meses por motivo de minimizar el riesgo de acortar su vida útil.

- 2) Al instalar la batería, los terminales positivo y negativo de la batería deben estar conectados de manera correcta. Si los terminales positivo y negativo de la batería están en cortocircuito, lo que podría causar daños al automóvil.
- 3) Solo los adultos pueden reemplazar las baterías.
- 4) La recarga de las baterías debe ser realizada por los adultos.
- 5) No puede cargar las baterías no recargables.
- 6) Antes de recargar las baterías recargables, asegúrese de retirarlas del control remoto.
- 7) No mezcle las baterías de distintos tipos.
- 8) No mezcle las baterías viejas y nuevas.
- 9) Después de almacenar el automóvil durante largo plazo, asegúrese de quitar las baterías del automóvil.
- 10) Debe retirar las baterías usadas en exceso.

2.Advertencia sobre el producto

- 1) Las piezas premontadas pueden estar afiladas; el montaje de este automóvil debe ser realizado por un adulto. Mantenga las piezas alejadas de los niños pequeños.
- 2) Por motivo de evitar la asfixia, mantenga las bolsas de plástico alejadas de los niños. Deseche todas las bolsas de inmediato.
- 3) Cuando los niños montan este automóvil, se requiere la supervisión de un adulto responsable.
- 4) Este automóvil debe ser conducido sobre un terreno llano y nivelado. No lo conduzca en vías públicas, pendientes pronunciadas o cerca de piscinas.
- 5) Use zapatos cuando conduzca este automóvil. Tome medidas de protección, por ejemplo, abrocharse el cinturón de seguridad, usar casco, guantes, rodilleras, etc.
- 6) Inspeccione la batería, el cargador, el cable, el enchufe, la carcasa y otras partes con regularidad. Si encuentre algún daño, no utilice el automóvil hasta que haya sido reparado.
- 7) Este automóvil puede acomodar a un/a niño/a a la vez. La carga máxima es de 30 kg, nunca exceda este límite.
- 8) Mantenga este automóvil fuera de alcance de llamas abiertas.
- 9) Guarde este manual bien para las referencias futuras.



ADVERTENCIA

- Se requiere la supervisión de un adulto con el fin de minimizar el riesgo de lesiones.
- Nunca utilice este automóvil en carreteras, cerca de los vehículos a motor, pendientes, piscinas o zonas donde haya agua.
- Use zapatos cuando conduzca este automóvil.
- Este automóvil solo puede ser utilizado por un/a niño/a a la vez.
- Antes de montar este automóvil, manténgalo alejado de los niños. Podría haber piezas pequeñas y afiladas, que podrían ser peligrosas.
- Este automóvil debe ser ensamblado por los adultos.



ADVERTENCIA

No mezcle las baterías alcalinas, estándar (carbono-zinc) o recargables (níquel-cadmio).



ADVERTENCIA

Debe usar el equipo de protección. No utilice este automóvil en el tráfico.



18-36
mesi

IN221000463V02_UK_FR_DE_ES_IT

370-224V70_370-224V90

Quad Honda ATV Elettrico

Manuale di Istruzione e Funzionamento



CE



PRECAUZIONI:

- Questa confezione contiene parti di piccole dimensioni.
- L'assemblaggio deve essere eseguito da parte di un adulto.
- Prima di consegnarlo ai bambini, rimuovere tutti i sacchetti di plastica e gli imballaggi dei pneumatici.
- Si raccomanda l'uso dei dispositivi di protezione.
- Non può essere usata nel traffico.
- Conservare il presente manuale per il futuro riferimento.



AVVERTENZA

**RICHIESTO UN
ADULTO PER
ASSEMBLAGGIO.**







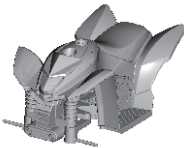
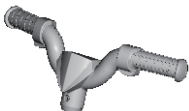

IMPORTANTE! CONSERVARE IL PRESENTE MANUALE PER FUTURO RIFERIMENTO E LEGGERLO ATTENTAMENTE.

ISTRUZIONI DI ASSEMBLAGGIO

I. SPECIFICHE

Età adatta	18-36 meses
Dimensioni del prodotto	65,5x38,5x43,5cm
Peso massimo	25 kilos
Velocità	2,8km/h
Motore	30w
Caricabatterie	Ingresso: AC120V -240V
	Uscita: CC 6V/500MA
Batteria	6V4A
Temperatura ambiente di funzionamento	0- 40°C

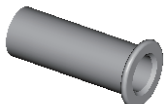
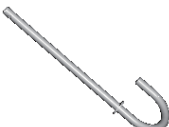
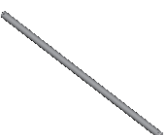
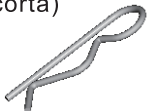
II. Components List

1. 1xCorpo 	2. 1xManubrio 	3. 2xRuota anteriore 	4. 2xRuota posteriore 
5. 4xCerchione 	6. 1xParaurti 	7. 1x Motore 	8. 1xDistanziatore 
9. 1xBastone J 	10. 1xAsse 	11. 5xCoppiglia a molla R (un pezzo di scorta) 	12. 7xRondella (un pezzo di scorta) 
13. 1x Caricabatterie 			

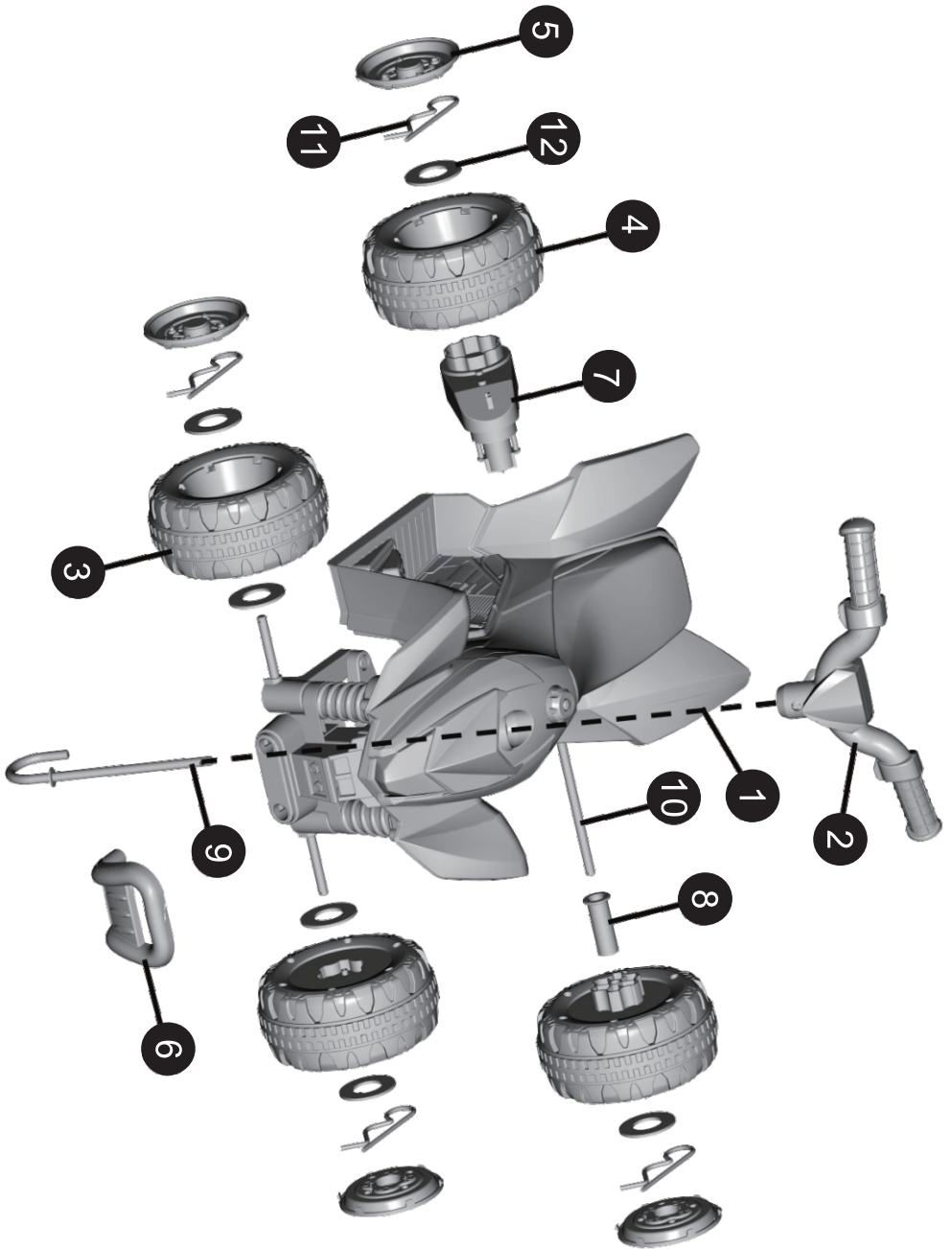

III. Istruzioni di assemblaggio

< 1 >

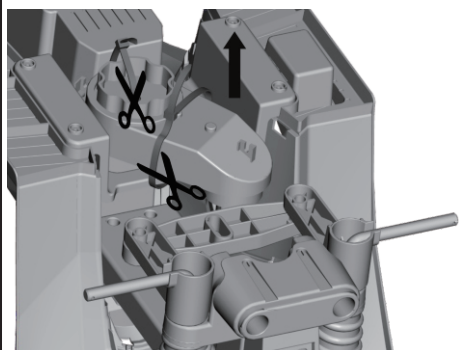

< 2 >

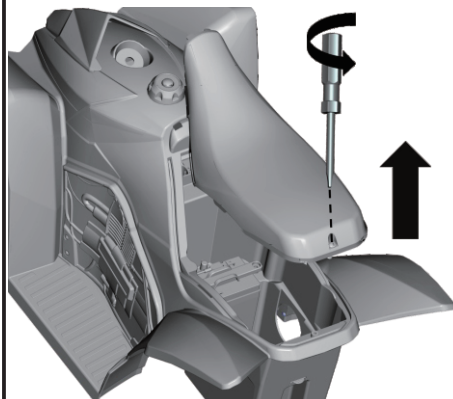

< 3 >

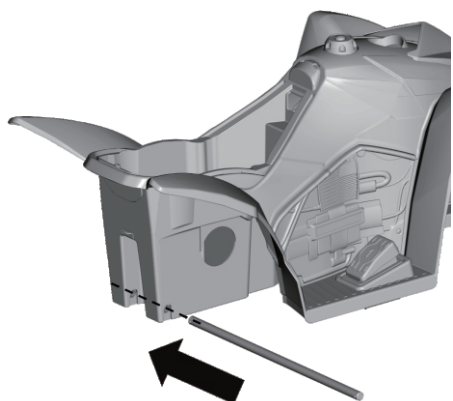

< 4 >

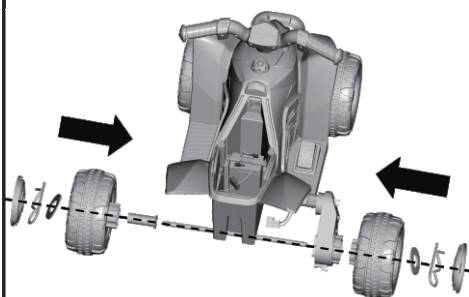

< 5 >

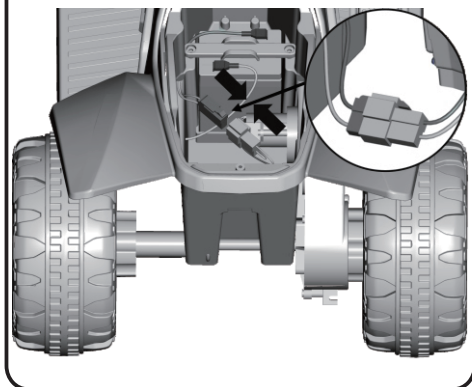

Per favore, rimuovi il motore e
assemblalo sulla macchina.
(Step 4 Come assemblare)

< 6 >

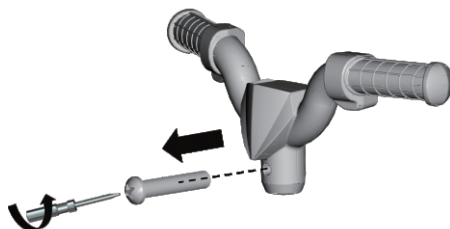

< 7 >

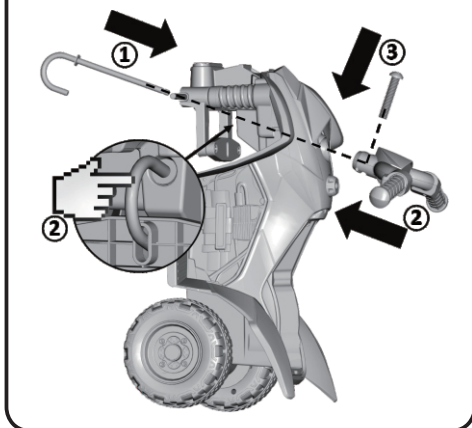

< 8 >

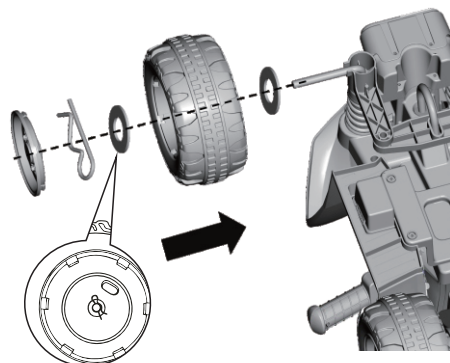

< 9 >

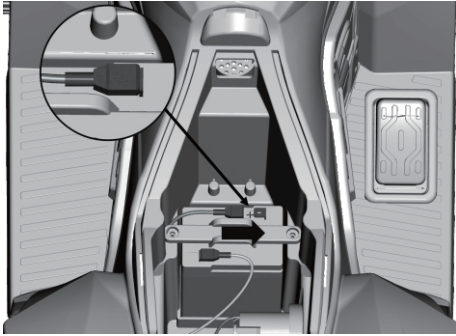

< 10 >

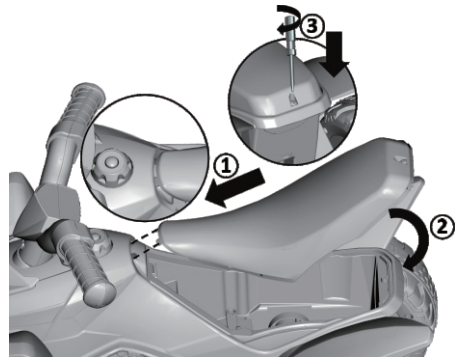

< 11 >

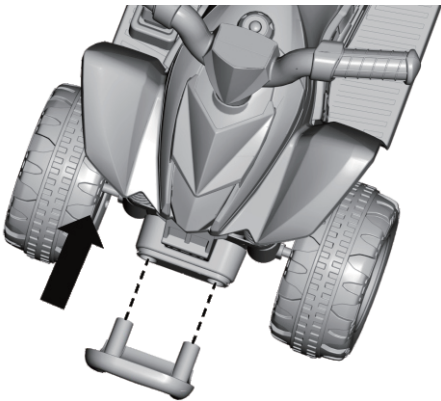

IV. Funzionamento e utilizzo

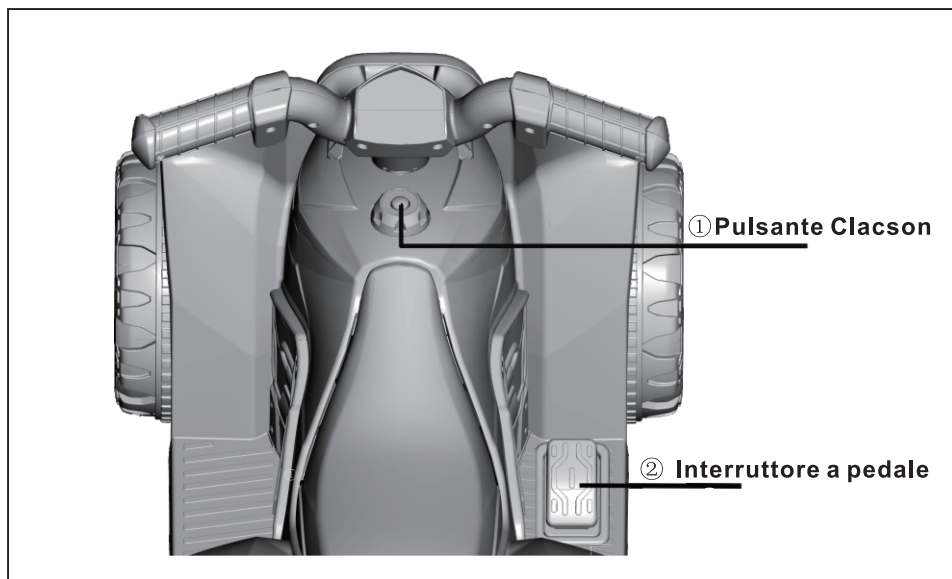

V. Uso e ricarica della batteria

1. La presa di ricarica è situata sulla parte posteriore.
2. Utilizzare solo la batteria e il caricabatterie in dotazione o consigliati.
3. Non giocare con il caricabatterie e la batteria.
4. Le batterie devono essere ricaricate da adulti.
5. La batteria deve essere completamente carica prima del primo utilizzo; il tempo di ricarica della batteria deve essere di 9-10 ore e non può superare le 15 ore.
6. Durante la ricarica, è normale un riscaldamento tiepido del caricabatterie e della batteria

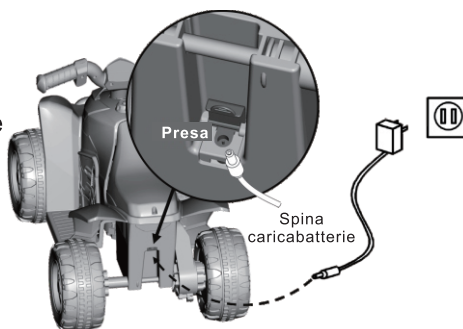

VI. Avvertenze

1. Avvertenze sulla batteria:

- 1) Quando non si usa l'auto per un lungo periodo, ricaricare appieno la batteria, e poi spegnerla. La batteria dovrebbe essere ricaricata una volta ogni due mesi, per ridurre al minimo il rischio di accorciare la sua durata.
- 2) Quando si installa la batteria, i poli positivo e negativo devono essere collegati correttamente. Il cortocircuito dei poli positivo e negativo potrebbe danneggiare il prodotto.
- 3) La sostituzione delle batterie deve essere eseguita solo da persone adulte.

- 4) La ricarica delle batterie deve essere effettuata da adulti.
- 5) Le batterie non ricaricabili non possono essere ricaricate.
- 6) Prima di ricaricare le batterie ricaricabili, accertarsi che siano state rimosse dal telecomando.
- 7) Non mischiare tipi diversi di batterie.
- 8) Non mischiare batterie vecchie e nuove.
- 9) Quando non si usa l'auto per un lungo periodo di tempo, assicurarsi che le batterie siano rimosse.
- 10) Le batterie utilizzate eccessivamente devono essere rimosse.

2. Avvertenze sul prodotto

- 1) Le parti preassemblate possono essere taglienti - l'assemblaggio del prodotto deve essere effettuato da un adulto. Tenere le parti lontano dalla portata dei bambini.
- 2) Per evitare il soffocamento, tenere i sacchetti di plastica lontano dai bambini. Smaltire immediatamente tutti i sacchetti.
- 3) Quando i bambini guidano questo prodotto, è richiesta la supervisione di un adulto.
- 4) Questa macchina deve essere guidata su un terreno pianeggiante e uniforme. Non guidare su strade pubbliche, colline ripide o in prossimità di piscine.
- 5) Indossare scarpe quando si utilizza questo prodotto. Adottare misure di protezione, come allacciare la cintura di sicurezza e indossare casco, guanti, ginocchiere ecc.
- 6) Non adatto a bambini di età inferiore ai tre anni.
- 7) Controllare regolarmente la batteria, il caricabatterie, il cavo, la spina, l'involucro e altre parti. In caso di danni, non utilizzare il prodotto finché non è stato riparato.
- 8) Questo prodotto può essere utilizzato da un bambino alla volta. Il carico massimo è di 30 kg: non superare questo limite.
- 9) Tenere il prodotto lontano da fiamme libere.
- 10) Conservare questo manuale per futuro riferimento.



AVVERTENZA

- È richiesta la supervisione di un adulto per ridurre al minimo il rischio di lesioni.
- Non utilizzare su strade, vicino a veicoli a motore, pendii, piscine o aree con presenza di acqua.
- Indossare scarpe quando si usa questo prodotto cavalcabile.
- Può essere utilizzato da un solo bambino alla volta.
- Prima di assemblare il prodotto, tenerlo lontano dalla portata dei bambini. Potrebbero esserci parti piccole e taglienti, che presenterebbero pericolose.
- Questo prodotto deve essere assemblato da un adulto.
- Utilizzare sempre questo prodotto con cautela. Sono necessarie abilità e vigilanza per evitare cadute e collisioni.



AVVERTENZA

Non mescolare batterie alcaline, standard (carbonio-zinco) o ricaricabili (nichel-cadmio).



AVVERTENZA

Si devono indossare i dispositivi di protezione. Non guidare nel traffico.

UK

If you have any questions, please contact our customer care center.

Our contact details are below:



0044-800-240-4004



enquiries@mhstar.co.uk

IMPORTER ADDRESS:

MH STAR UK LTD
Unit 27, Perivale Park,
Horsenden lane South
Perivale, UB6 7RH
MADE IN CHINA

FR

Si vous avez la moindre question, veuillez contacter notre centre d'assistance à la clientèle.

Nos coordonnées sont les suivantes:



0033-1-84166106



aosom@mhfrance.fr

Importé par:

MH France
2, rue Maurice Hartmann
92130 Issy-les-Moulineaux
France
Fabriqué en Chine

DE

Wenn Sie Fragen haben, wenden Sie sich bitte an unser Kundendienstzentrum.

Unsere Kontaktdaten stehen unten:



0049-(0)40-88307530



service@aosom.de

ADRESSE DES IMPORTEUR:

MH Handel GmbH
Wendenstraße 309
D-20537 Hamburg
Germany
IN CHINA HERGESTELLT

ES

Si tiene alguna pregunta, comuníquese con nuestro Centro de Atención al Cliente. Nuestros datos de contacto son los siguientes:



0034-931294512



atencioncliente@aosom.es

IMPORTADOR:

SPANISH AOSOM, S.L.
C/ ROC GROS, N° 15. 08550, ELS HOSTALETS DE
BALENYÀ, SPAIN.
B66295775
WWW.AOSOM.ES
ATENCIONCLIENTE@AOSOM.ES
TEL: 931294512
HECHO EN CHINA

PT

Se tiver alguma dúvida, por favor contacte o nosso Centro de Atendimento ao Cliente. Os nossos dados de contacto são os seguintes:



0034-931294512



info@aosom.pt.

IMPORTADOR:

SPANISH AOSOM, S.L
C.ROC GROS N.15, 08550. ELS HOSTALETS DE BALENYÀ
TEL: 931294512 (SEG-SEX DAS 7:30H ÀS 16:30H)
INFO@AOSOM.PT
WWW.AOSOM.PT

IT

In caso di dubbio, si prega di contattare il nostro centro assistenza clienti.

I nostri dettagli di contatto sono di seguito:



0039-0249471447



clienti@aosom.it

IMPORTATO DA:

AOSOM Italy srl
Centro Direzionale Milanofiori
Strada 1 Palazzo F1
20057 Assago (MI)
P.I.: 08567220960
FATTO IN CINA

