

# AIYAPLAY

EN

IN221000610V02\_UK

**370-223V00**

## Ride-on car

Instruction manual



**WARNING**

**ADULT ASSEMBLY  
REQUIRED.**



**12-36**  
months



The packaging has to be kept since it contains important information. The “Automobili Lamborghini” and “Automobili Lamborghini Bull and Shield” trademarks, copyrights, designs and models are used under license from Automobili Lamborghini S.p.A, Italy.  
Licensee: Ningbo Prince Toys Co., Ltd.

**IMPORTANT, RETAIN FOR FUTURE REFERENCE: READ CAREFULLY**

# ASSEMBLY INSTRUCTION

## **Warning**

1. This ride-on is for ages 12-36 months. The maximum weight capacity is 25kg.
2. This product can fit one child at a time.
3. Adult supervision is advised, ensuring children ride safely.
4. Adult assembly is required.
5. Batteries to be handled by adults only.
6. When riding, avoid going near streets, crossroads, traffic areas, swimming pools and stairs.
7. Regularly check the product for any damaged parts.
8. Occasionally check the nut and bolt on the steering wheel, ensuring it is tight and secure.
9. Ensure this product is properly assembled before using.
10. Wear shoes when riding this product.

## **Battery handling:**

1. Battery must be handled by adults only.
2. Always remove dead batteries.
3. Only use AA batteries.
4. Alkaline batteries are recommended.
5. When the product is not being used for a while, remove the batteries.
6. When changing batteries, ensure they are all changed with new ones.
7. Do not mix old and new batteries.
8. Do not mix alkaline, standard (carbon-zinc) or rechargeable (nickel-cadmium) batteries.
9. Do not throw batteries into a fire – they could explode or leak.
10. Do not charge non-rechargeable batteries.
11. Before charging, remove chargeable batteries from the product.
12. Adult supervision is required when charging batteries.
13. Insert batteries with the correct polarity.
14. Ensure supply terminals are not short-circuited

# COMPONENTS LIST

	<p>1. 1 x J-shaped stick</p>	<p>2. 1 x Body</p>
	<p>3. 1 x Safety bar fixed part</p>	<p>4. 1 x Steering wheel</p>
	<p>5. 1 x Backrest</p>	<p>6. 2 x Safety bar</p>
	<p>7. 2 x Thumb latch</p>	<p>8. 3 x Nut x 3 (one replacement piece)</p>
	<p>9. 1 x Push bar</p>	<p>10. 3 x Bolt (one replacement piece)</p>
	<p>11. 1 x Connect tube</p>	

## ASSEMBLY

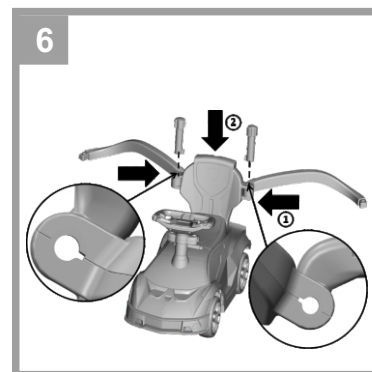
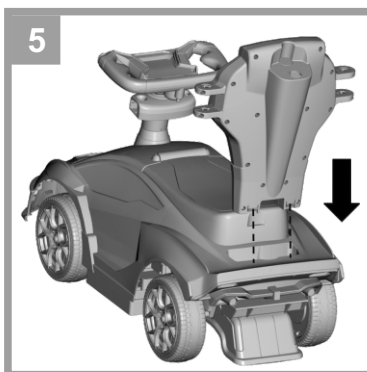
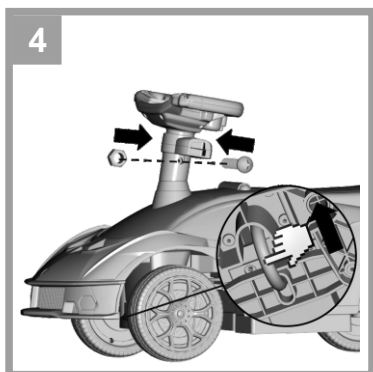
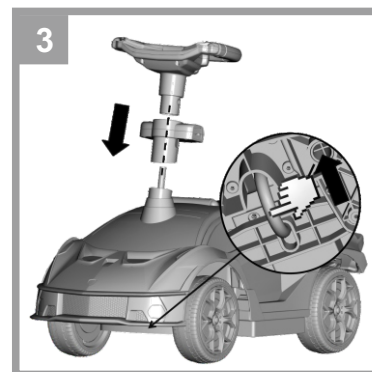
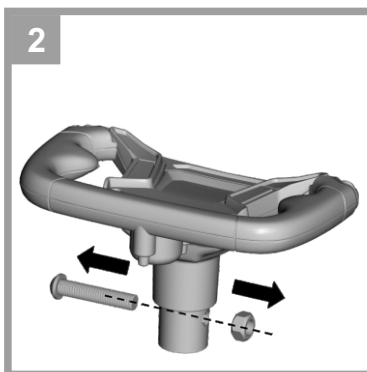
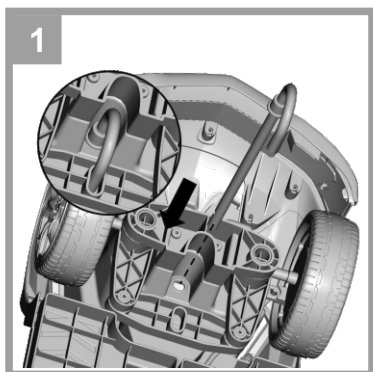

## ASSEMBLY

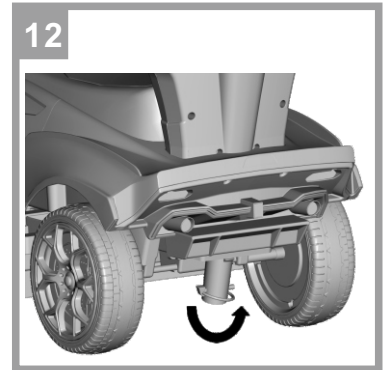
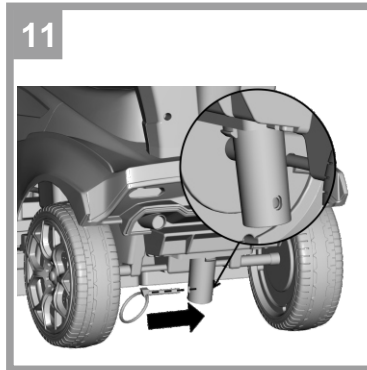
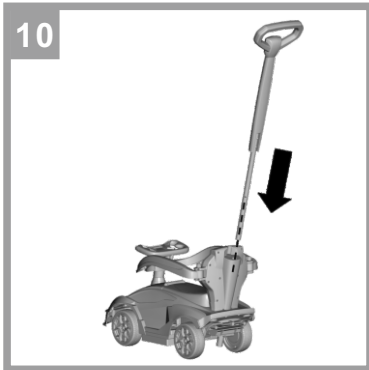
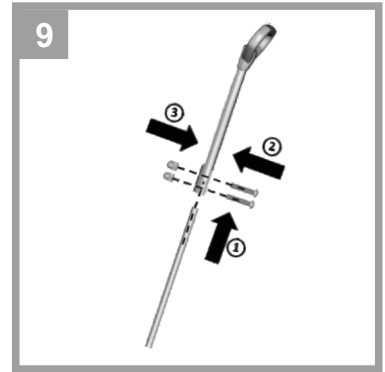
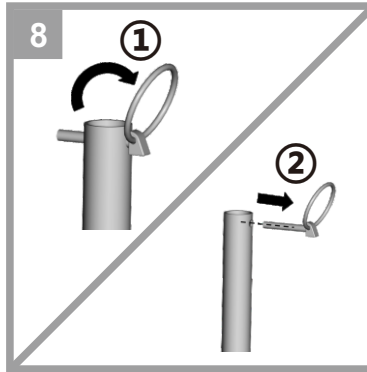
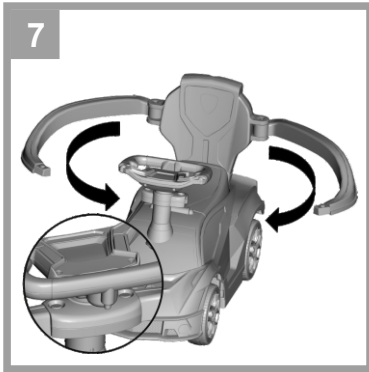

## BATTERY CHANGE

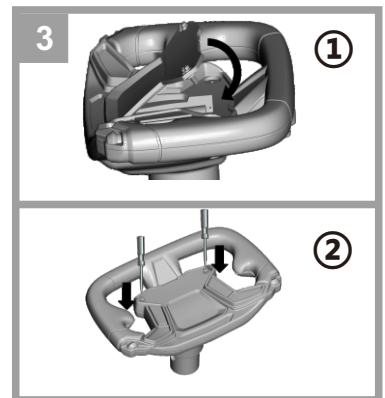
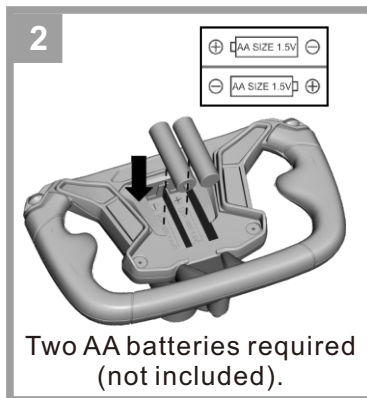
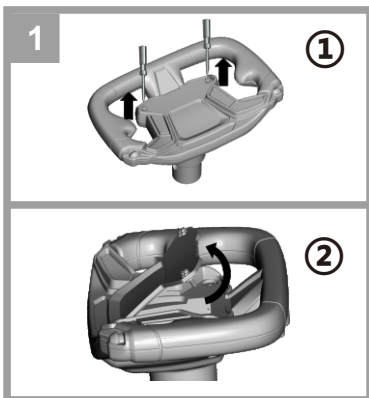

If you have any questions, please contact our customer care center.  
Our contact details are below:

 0044-800-240-4004

 [enquiries@mhstar.co.uk](mailto:enquiries@mhstar.co.uk)

IMPORTER ADDRESS:  
MH STAR UK LTD  
Unit 27, Perivale Park,  
Horsenden lane South  
Perivale, UB6 7RH  
MADE IN CHINA



# AIYAPLAY

FR

IN221000610V02\_FR

**370-223V00**

## Voiture Autoportée Électrique

Manuel d' Instruction

 **AVERTISSEMENT**  
**ASSEMBLAGE PAR UN**  
**ADULTE REQUIS**



Les emballages doivent être conservés car ils contiennent des informations importantes.

Les marques, droits d'auteur, dessins et modèles "Automobili Lamborghini" et "Automobili Lamborghini Bull and Shield" sont exploités sous licence de Automobili Lamborghini S.p.A., Italie.

Titulaire de la licence : Ningbo Prince Toys Co.,Ltd.

**IMPORTANT : A LIRE ATTENTIVEMENT ET À CONSERVER POUR CONSULTATION ULTÉRIEURE.**

## **INSTRUCTIONS D'ASSEMBLAGE**

## **Avertissement**

1. Cette voiture autoportée est destinée aux enfants de 12 à 36 mois. Sa capacité de charge maximale est de 25 kg.
2. Ce produit ne peut accueillir qu'un seul enfant à la fois.
3. La surveillance d'un adulte est conseillée afin de garantir la sécurité des enfants.
4. L'assemblage par un adulte est nécessaire.
5. Les piles doivent être manipulées par des adultes uniquement.
6. Lorsque vous roulez, évitez de conduire à proximité des rues, des carrefours, des zones de circulation, des piscines et des escaliers.
7. Vérifiez régulièrement que le produit ne présente pas de pièces endommagées.
8. Vérifiez de temps en temps l'écrou et le boulon du volant, en vous assurant qu'ils sont bien serrés et sécurisés.
9. Assurez-vous que ce produit est correctement assemblé avant de l'utiliser.
10. Portez des chaussures lorsque vous conduisez ce produit.

## **Manipulation de la pile:**

1. La pile doit être manipulée par des adultes uniquement.
2. Retirez toujours les piles mortes.
3. N'utilisez que des piles AA.
4. Il est recommandé d'utiliser des piles alcalines.
5. Retirez les piles lorsque le produit n'est pas utilisé pendant un certain temps.
6. Lorsque vous changez les piles, assurez-vous qu'elles sont toutes remplacées par des piles neuves.
7. Ne mélangez pas les anciennes et les nouvelles piles.
8. Ne mélangez pas des piles alcalines, standard (carbone-zinc) ou rechargeables (nickel-cadmium).
9. Ne jetez pas de piles dans un feu - elles pourraient provoquer une explosion ou suinter dans le sol.
10. Ne chargez pas les piles non rechargeables.
11. Avant de charger les piles, retirez-les du produit.
12. La surveillance d'un adulte est requise lors du chargement des piles.
13. Insérez les piles en respectant la polarité.
14. Veillez à ce que les bornes d'alimentation ne soient pas court-circuitées.

# LISTE DES PIÈCES

	<p>1.1 x Pièce en forme de J</p>	<p>2. 1 x Carrosserie</p>
	<p>3.1 x Pièce fixe de la barre de sécurité</p>	<p>4.1 x Volant de direction</p>
	<p>5.1 x Dossier</p>	<p>6. 2 x Barre de sécurité</p>
	<p>7.2 x Loquet</p>	<p>8. 3 x Ecrou x 3 (une pièce de rechange)</p>
	<p>9.1 x Barre de poussée</p>	<p>10. 3 x Boulon (une pièce de rechange)</p>
<p>11.1 x Tube de connexion</p>		

## ASSEMBLAGE

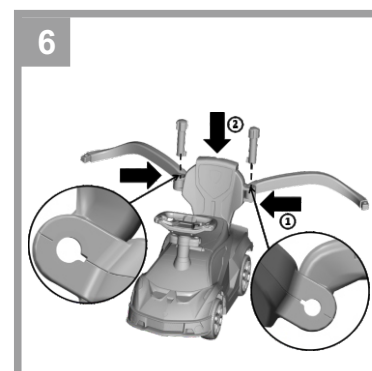
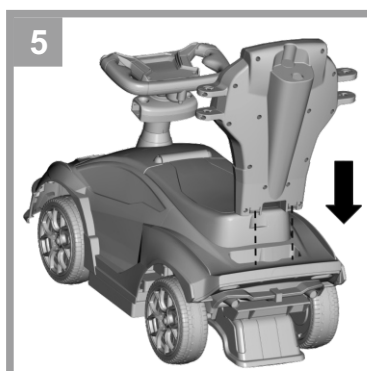
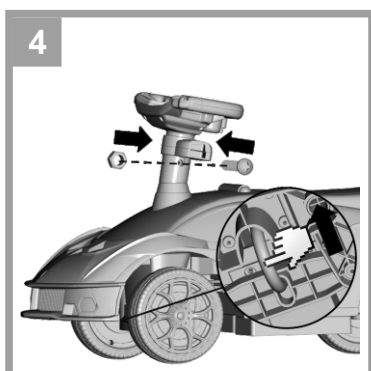
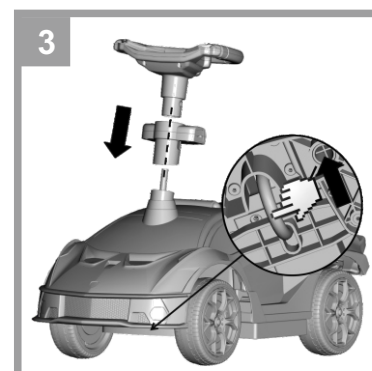
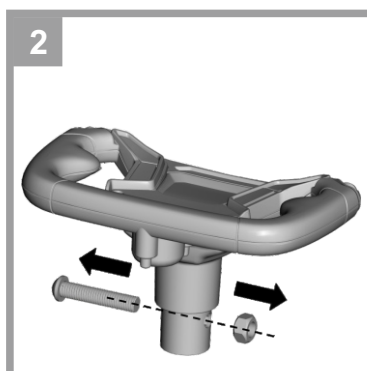
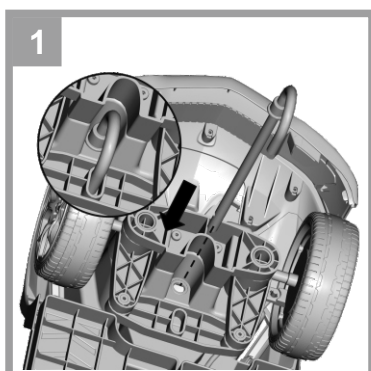

## ASSEMBLAGE

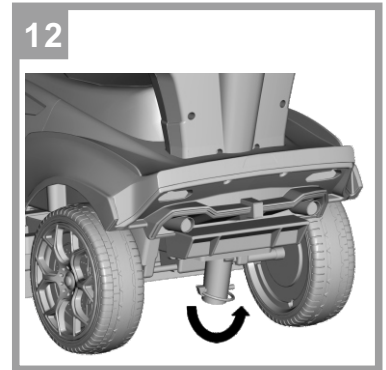
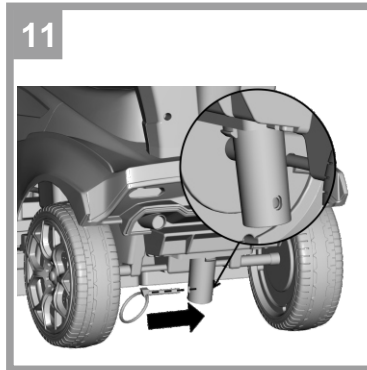
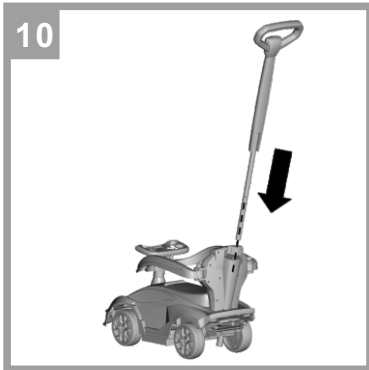
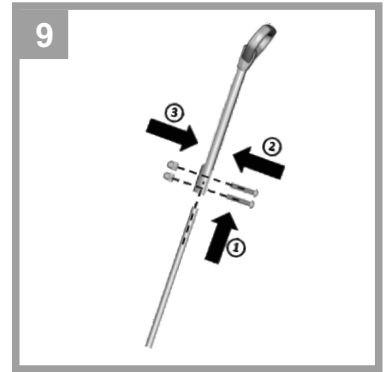
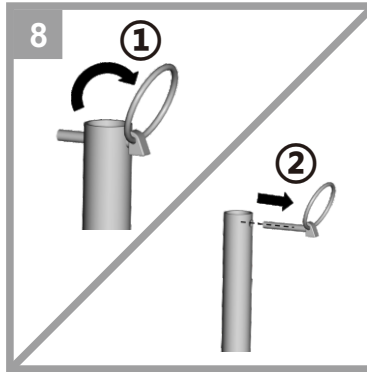
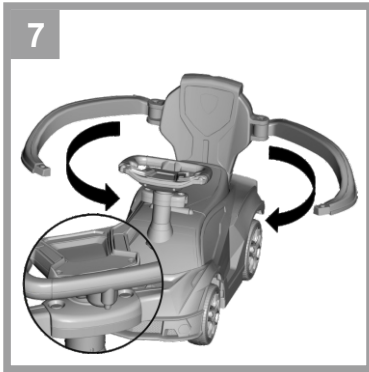

## REEMPLACEMENT DES PILES

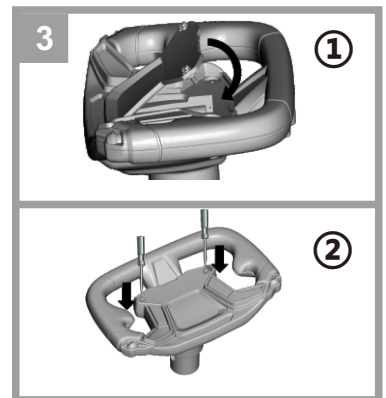
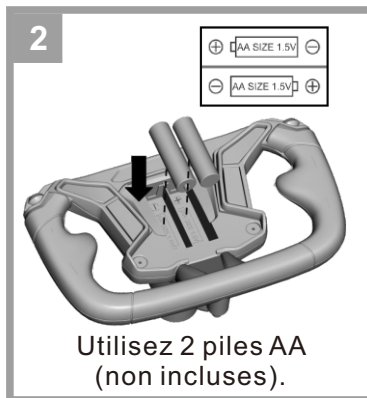
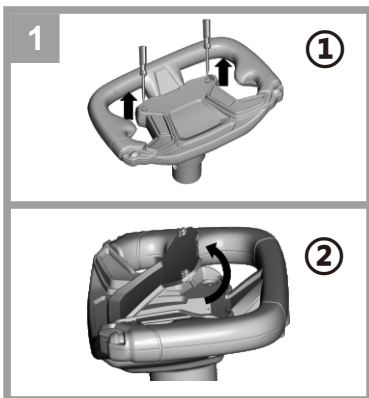

Si vous avez la moindre question, veuillez contacter notre centre d'assistance à la clientèle. Nos coordonnées sont les suivantes:

☎ 0033-1-84166106

✉ aosom@mhfrance.fr

Importé par :  
MH France  
2, rue Maurice Hartmann  
92130 Issy-les-Moulineaux  
France  
Fabriqué en Chine



FR  
**DONNEZ  
OU  
RECYCLEZ**



ASSOCIATION

OU



LIVRAISON

OU



DÉCHÈTERIE

Adresses sur [quefairedemesdechets.fr](http://quefairedemesdechets.fr)

# AIYAPLAY

DE

IN221000610V02\_DE

**370-223V00**

## Aufsitzauto

Gebrauchsanweisung

 **WARNUNG**

Montage durch einen  
Erwachsenen  
erforderlich



Die Verpackung muss aufbewahrt werden, da sie wichtige Informationen enthält.  
Die Marken „Automobili Lamborghini“ und „Automobili Lamborghini Bull and  
Shield“, Warenzeichen, Designs und Modelle werden unter Lizenz von  
Automobili Lamborghini S.p.A, Italien, verwendet.  
Lizenznehmer: Ningbo Prince Toys Co., Ltd.

**WICHTIG! SORGFÄLTIG LESEN UND FÜR SPÄTER NACHSCHLAGEN  
AUFBEWAHREN.**

## MONTAGEANWEISUNGEN

# **Warnung**

1. Dieses Aufsitzauto ist für Kinder zwischen 12 und 36 Monaten geeignet. Die maximale Gewichtskapazität beträgt 25 kg.
2. Dieses Produkt ist für jeweils ein Kind geeignet.
3. Die Aufsicht durch einen Erwachsenen wird empfohlen, damit die Kinder sicher fahren.
4. Die Montage durch einen Erwachsenen ist erforderlich.
5. Die Batterien dürfen nur von Erwachsenen gehandhabt werden.
6. Vermeiden Sie beim Fahren die Nähe von Straßen, Kreuzungen, Verkehrsflächen, Schwimmbädern und Treppen.
7. Überprüfen Sie das Produkt regelmäßig auf beschädigte Teile.
8. Überprüfen Sie gelegentlich die Schrauben und Muttern am Lenkrad und stellen Sie sicher, dass sie fest angezogen und sicher sind.
9. Stellen Sie vor der Verwendung sicher, dass das Produkt richtig zusammengebaut ist.
10. Tragen Sie beim Fahren mit diesem Produkt Schuhe.

## **Handhabung der Batterie:**

1. Die Batterie darf nur von Erwachsenen gehandhabt werden.
2. Entfernen Sie immer leere Batterien.
3. Verwenden Sie nur AA-Batterien.
4. Es werden Alkalibatterien empfohlen.
5. Entfernen Sie die Batterien, wenn das Produkt eine Zeit lang nicht benutzt wird.
6. Achten Sie beim Auswechseln der Batterien darauf, dass alle durch neue ersetzt werden.
7. Vermischen Sie alte und neue Batterien nicht.
8. Mischen Sie keine Alkali-, Standard- (Kohle-Zink) oder wiederaufladbare (Nickel-Cadmium) Batterien.
9. Werfen Sie Batterien nicht ins Feuer – sie könnten explodieren oder auslaufen.
10. Laden Sie keine nicht wiederaufladbaren Batterien auf.
11. Nehmen Sie aufladbare Batterien vor dem Aufladen aus dem Produkt.
12. Das Laden von Batterien muss unter Aufsicht von Erwachsenen erfolgen.
13. Setzen Sie die Batterien mit der richtigen Polarität ein.
14. Stellen Sie sicher, dass die Versorgungsklemmen nicht kurzgeschlossen sind.



# KOMPONENTENLISTE

	<p>1.1 x J-förmiger Stock</p>	<p>2.1 x Gehäuse</p>
	<p>3.1 x Festes Teil des Sicherheitsbügels</p>	<p>4.1 x Lenkrad</p>
	<p>5.1 x Rückenlehne</p>	<p>6.2 x Sicherheitsbügel</p>
	<p>7.2 x Daumenklinke</p>	<p>8.3 x Mutter x 3 (ein Ersatzteil)</p>
	<p>9.1 x Schubstange</p>	<p>10.3 x Schrauben (ein Ersatzteil)</p>
	<p>11.1 x Verbindungsrohr</p>	

## MONTAGE

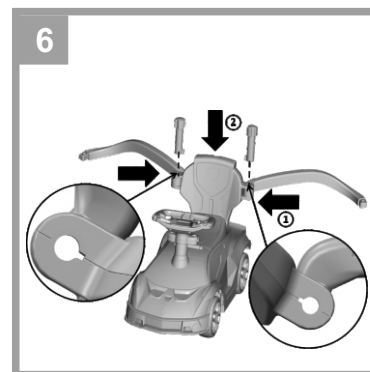
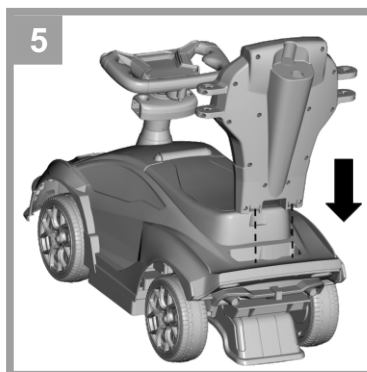
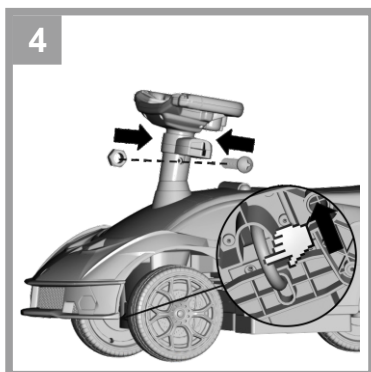
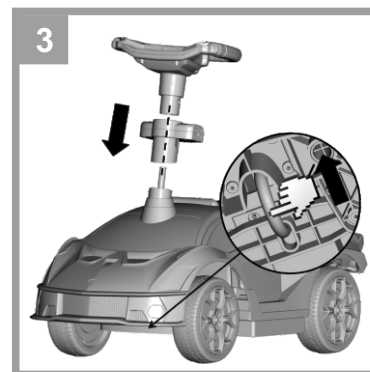
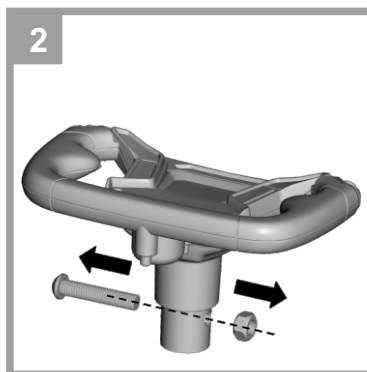
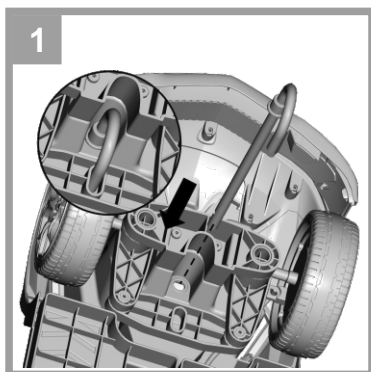

## MONTAGE

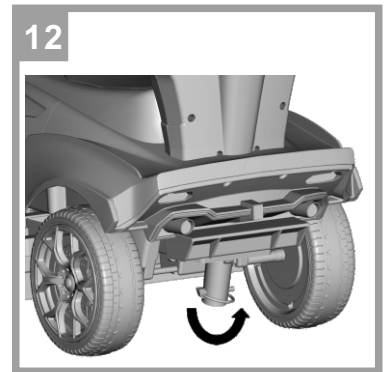
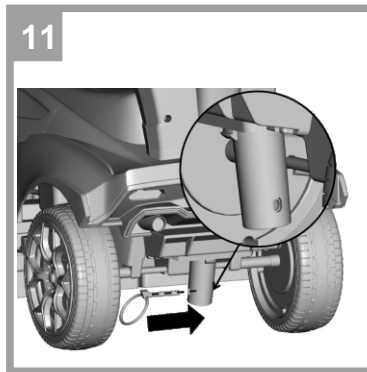
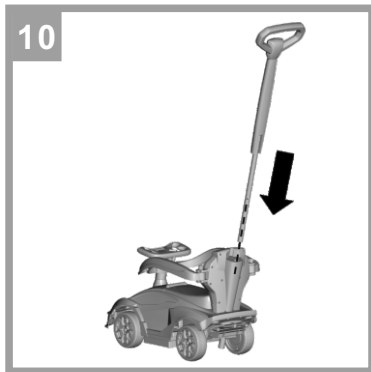
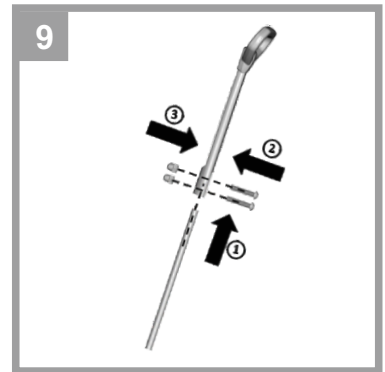
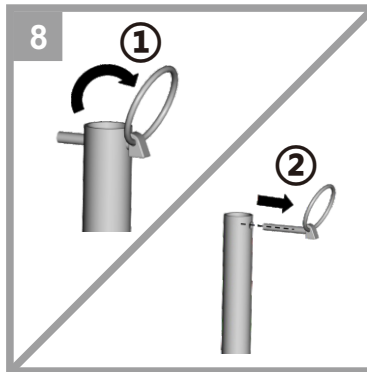
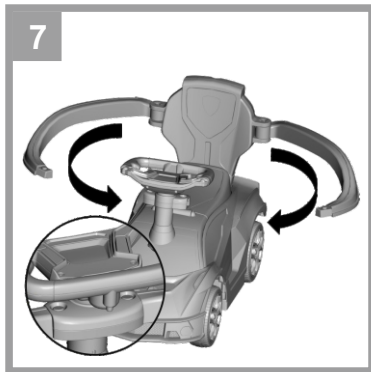

## BATTERIEWECHSEL

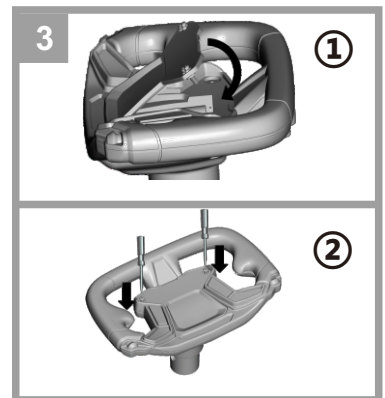
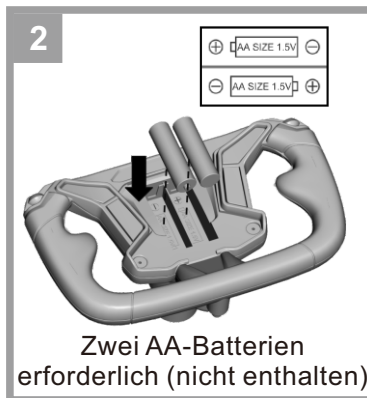
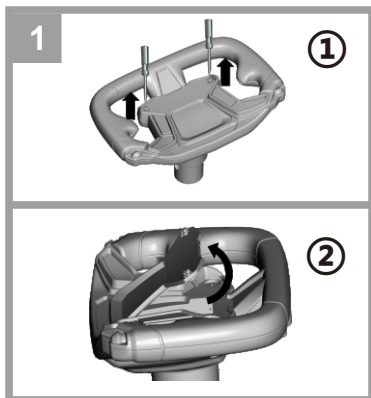

Wenn Sie Fragen haben, wenden Sie sich bitte an unser Kundendienstzentrum.  
Unsere Kontaktdaten stehen unten:

☎ 0049-0(40)-88307530

✉ [service@aosom.de](mailto:service@aosom.de)

ADRESSE DES IMPORTEURE:  
MH Handel GmbH  
Wendenstraße 309  
D-20537 Hamburg  
Germany  
IN CHINA HERGESTELLT

# AIYAPLAY

ES

IN221000610V02\_ES

**370-223V00**

## Ride-on Automóvil

Manual de instrucciones



**ADVERTENCIA**  
EL MONTAJE DEBE  
SER REALIZADO POR  
ADULTOS



Debe guardar el embalaje bien, ya que contiene información importante.  
Las marcas comerciales, los derechos de autor, los diseños y los modelos de  
“Automobili Lamborghini” y “Automobili Lamborghini Bull and Shield” se utilizan  
bajo autorización de Automobili Lamborghini S.p.A, Italia.  
Licenciatarario: Ningbo Prince Toys Co., Ltd.

**IMPORTANTE, LEA DETENIDAMENTE Y GUARDE PARA FUTURAS  
REFERENCIAS.**

## INSTRUCCIONES DE MONTAJE

# Advertencia

1. Este Ride-on automóvil es apto para los niños de 12 a 36 meses. La capacidad de carga máxima de peso es de 25 kg.
2. Este automóvil puede acomodar a un/a niño/a a la vez.
3. Se recomienda la supervisión de un adulto responsable para garantizar que los niños viajen seguramente.
4. El montaje debe ser realizado por los adultos.
5. Las baterías solo deben ser manipuladas por los adultos.
6. Al conducir este automóvil, evite acercarse a las calles, las intersecciones, los áreas de tráfico, las piscinas y las escaleras.
7. Inspeccione el automóvil con regularidad en busca de cualquier pieza dañada.
8. Inspeccione la tuerca y el perno en el volante de vez en cuando para asegurarse de que estén apretados firmemente y seguros.
9. Asegúrese de que este automóvil esté montado de manera correcta antes de utilizarlo.
10. Use zapatos cuando utilice este automóvil.

## **Manejar las baterías:**

1. Las baterías solo deben ser manipuladas por los adultos.
2. Siempre retire las baterías agotadas.
3. Solo utilice las baterías AA.
4. Se recomiendan utilizar las baterías alcalinas.
5. Cuando no utilice el automóvil durante largo plazo, retire las baterías.
6. Al reemplazar las baterías, asegúrese de reemplazar todas las baterías usadas por otras nuevas.
7. No mezcle las baterías viejas y nuevas.
8. No mezcle las baterías alcalinas, estándar (carbono-zinc) o recargables (níquel-cadmio).
9. No deseche las baterías al fuego, de lo contrario, las baterías podrían explotar o tener fugas.
10. No cargue las baterías no recargables.
11. Antes de cargar las baterías recargables, retírelas del automóvil.
12. Al cargar las baterías, se requiere la supervisión de un adulto responsable.
13. Inserte las baterías con los electrodos correctamente conectados.
14. Asegúrese de que los terminales de alimentación no estén en cortocircuito.

# LISTA DE COMPONENTES

	<p>1.1 x Palo en forma de "J"</p>	<p>2.1 x Carrocería de automóvil</p>
	<p>3.1 x Pieza de fijación de la barra de seguridad</p>	<p>4.1 x Volante</p>
	<p>5.1 x Respaldo</p>	<p>6. 2 x Barra de seguridad</p>
	<p>7.2 x Pestillo de pulgar</p>	<p>8. 3 x Tuerca x 3 (una pieza de repuesto)</p>
	<p>9.1 x Barra empujadora</p>	<p>10.3 x Tornillo (una pieza de repuesto)</p>
	<p>11.1 x Tubo de conexión</p>	

## MONTAJE

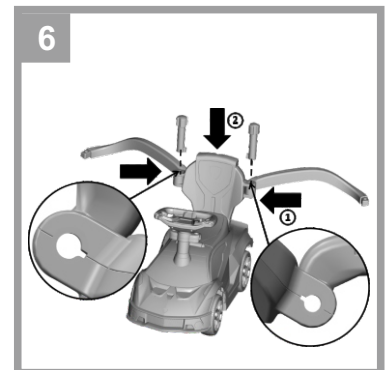
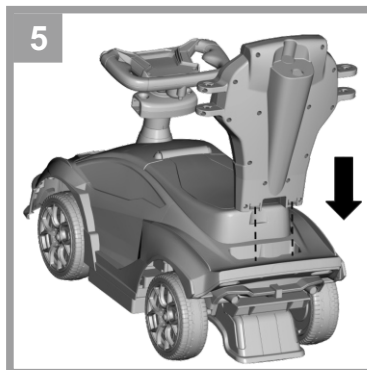
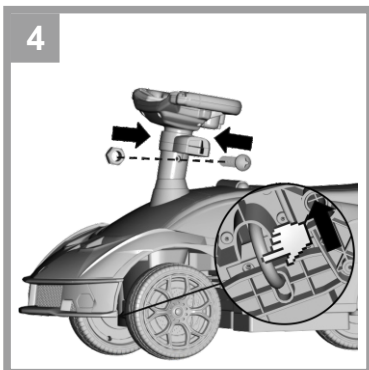
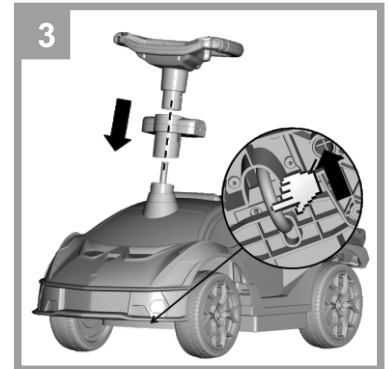
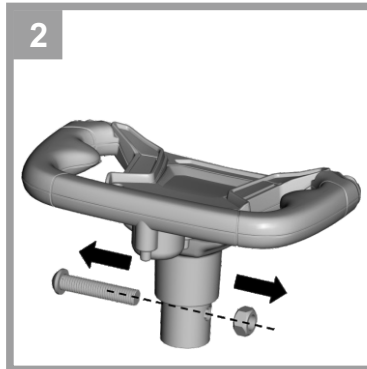
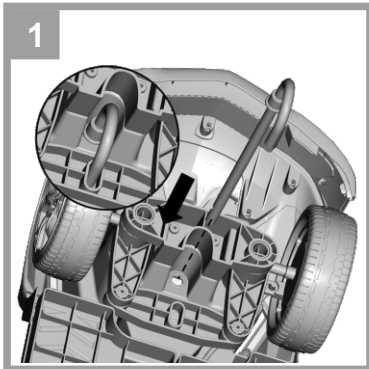



## MONTAJE

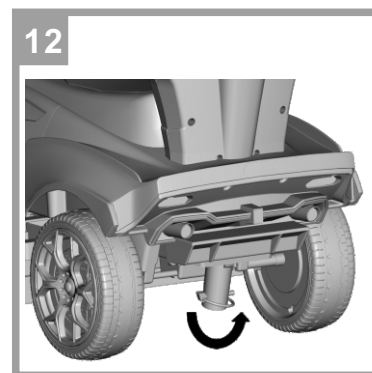
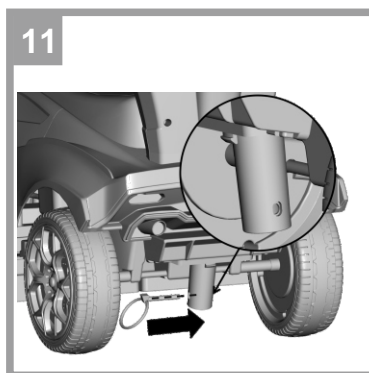
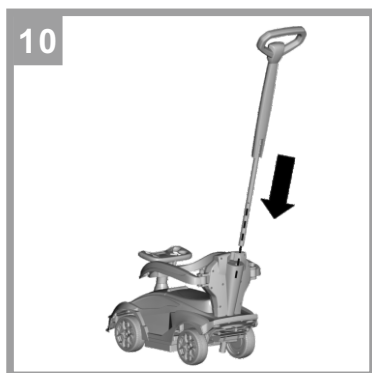
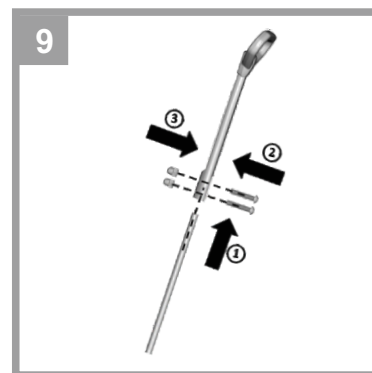
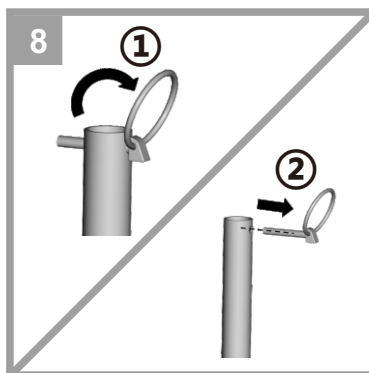
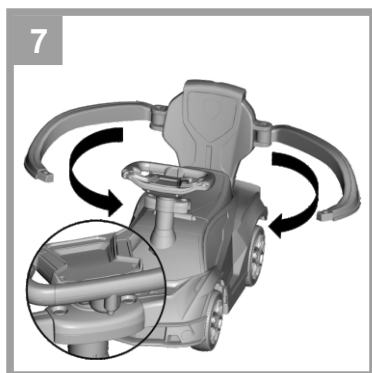

## REEMPLAZO DE BATERÍAS

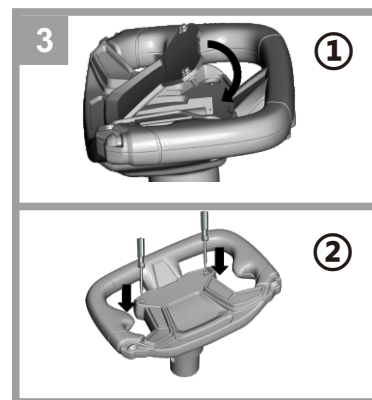
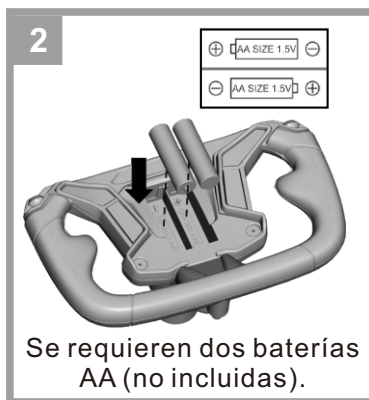
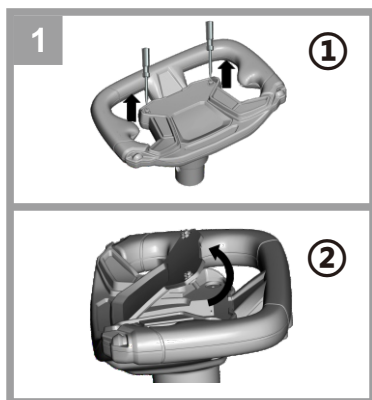

Si tiene alguna pregunta, comuníquese con nuestro Centro de Atención al Cliente. Nuestros datos de contacto son los siguientes:

☎ 0034-931294512

✉ [atencioncliente@aosom.es](mailto:atencioncliente@aosom.es)

IMPORTADOR:  
SPANISH AOSOM, S.L.  
C/ ROC GROS, N° 15. 08550, ELS HOSTALETS DE BALENYÀ, SPAIN.  
B66295775  
[WWW.AOSOM.ES](http://WWW.AOSOM.ES)  
[ATENCIONCLIENTE@AOSOM.ES](mailto:ATENCIONCLIENTE@AOSOM.ES)  
TEL: 931294512  
HECHO EN CHINA



# AIYAPLAY

IT

IN221000610V02\_IT

**370-223V00**

## Macchina Giocattolo

Manuale d'uso



**AVVERTENZA**

**NECESSARIO IL  
MONTAGGIO DA  
PARTE DI UN ADULTO**



**12-36**  
mesi



Conservare la confezione poiché contiene informazioni importanti.

I marchi, i diritti d'autore, i design e i modelli di "Automobili Lamborghini" e "Automobili Lamborghini Bull and Shield" sono stati utilizzati sotto licenza di Automobili Lamborghini S.p.A, Italia.

Licenziatario: Ningbo Prince Toys Co., Ltd.

**IMPORTANTE, LEGGERE E CONSERVARE QUESTO MANUALE  
D'ISTRUZIONE PER UN USO FUTURO.**

## **ISTRUZIONI DI ASSEMBLAGGIO**

# **Avvertenze**

1. Questa macchina giocattolo è progettata per bambini di età compresa tra 12 e 36 mesi. La portata massima è di 25 kg.
2. Questo prodotto è adatto ad essere usato da un bambino alla volta.
3. Si consiglia la supervisione di un adulto, assicurandosi che i bambini guidino in sicurezza.
4. È richiesto il montaggio da parte di un adulto.
5. Le batterie devono essere maneggiate solo da adulti.
6. Durante la guida, evitare di avvicinarsi a strade, incroci, zone trafficate, piscine e scale.
7. Controllare regolarmente il prodotto per rilevare eventuali parti danneggiate.
8. Controllare regolarmente il dado e il bullone sul volante, assicurandosi che siano ben stretti in sicurezza.
9. Assicurarsi che questo prodotto sia assemblato correttamente prima dell'uso.
10. Indossare scarpe quando si guida questo prodotto.

## **Gestione delle batterie:**

1. Le batterie devono essere maneggiate solo da adulti.
2. Rimuovere sempre le batterie scariche.
3. Utilizzare solo batterie AA.
4. Si consiglia l'uso di batterie alcaline.
5. Quando il prodotto non viene utilizzato a lungo, rimuovere le batterie.
6. Quando si sostituiscono le batterie, assicurarsi che siano tutte sostituite con batterie nuove.
7. Non mischiare batterie vecchie e nuove.
8. Non mischiare batterie alcaline, standard (carbone-zinco) o ricaricabili (nichel-cadmio).
9. Non smaltire le batterie nel fuoco: potrebbero esplodere o potrebbero esserci perdite.
10. Non tentare di ricaricare batterie non ricaricabili.
11. Prima della ricarica, rimuovere le batterie ricaricabili dal prodotto.
12. È necessaria la supervisione di un adulto durante la ricarica delle batterie.
13. Inserire le batterie secondo la polarità corretta.
14. Assicurarsi che i terminali di alimentazione non siano in stato di cortocircuito.

# LISTA COMPONENTI

	<p>1.1 x Staffa a J</p>	<p>2.1 x Carrozzeria</p>
	<p>3.1 x Raccordo di fissaggio della barra</p>	<p>4.1 x Volante</p>
	<p>5.1 x Schienale</p>	<p>6. 2 x Barra di sicurezza</p>
	<p>7. 2 x Raccordo chiuso</p>	<p>8. 3 x Dado x 3 (uno di ricambio)</p>
	<p>9. 1 x Barra di spinta</p>	<p>10. 3 x Bullone (uno di ricambio)</p>
	<p>11.1 x Tubo connettore</p>	

## ASSEMBLAGGIO

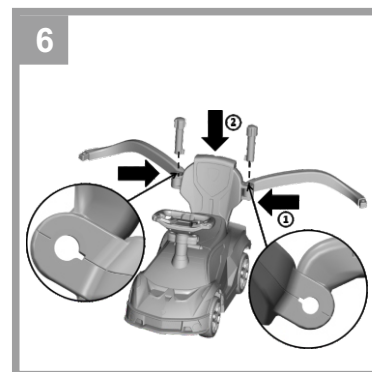
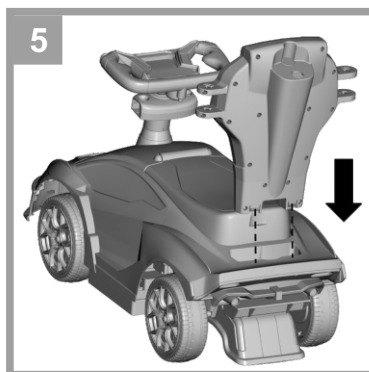
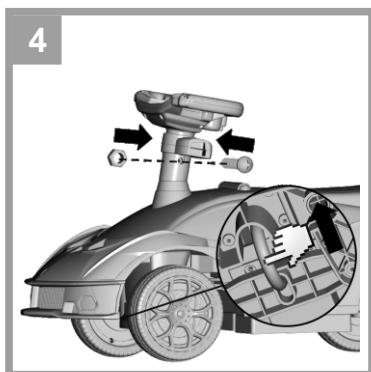
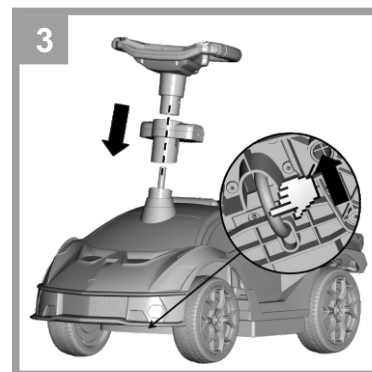
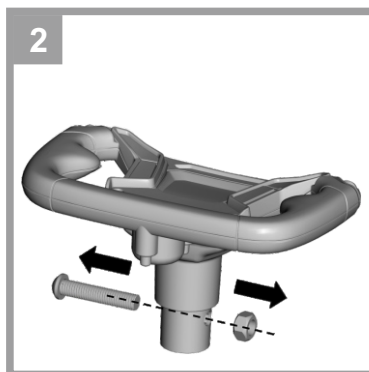
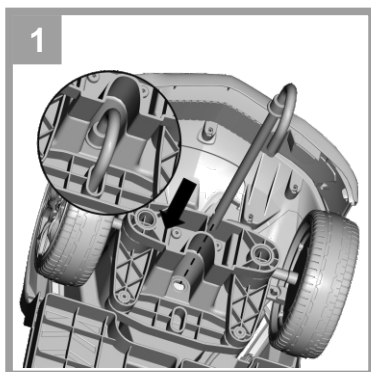

## ASSEMBLAGGIO

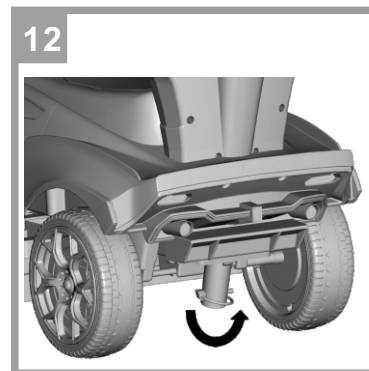
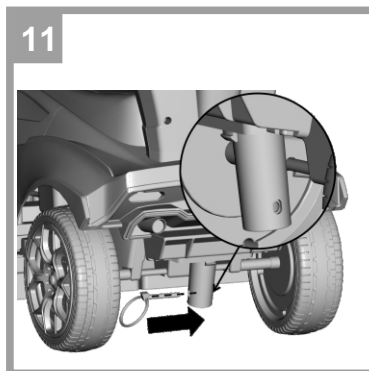
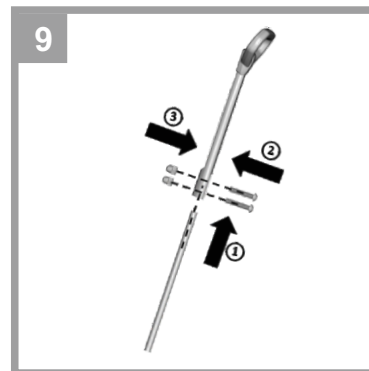
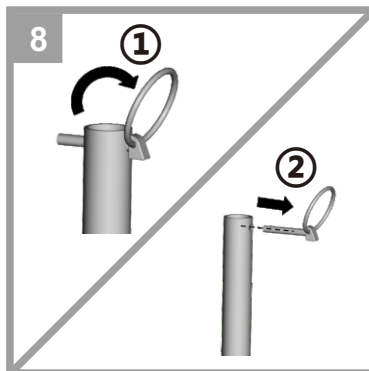
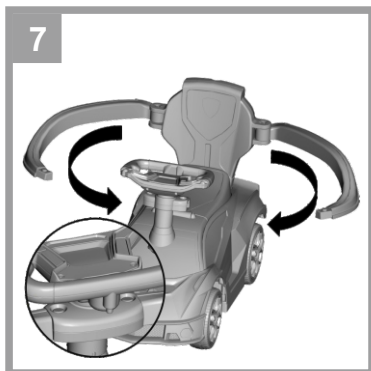

## SOSTITUZIONE DELLA BATTERIA

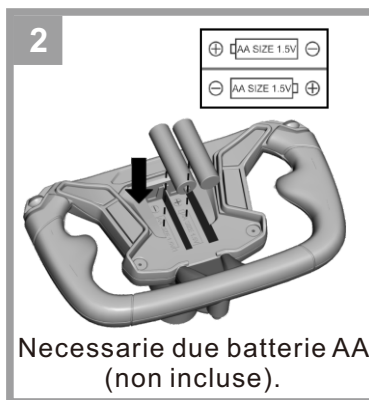
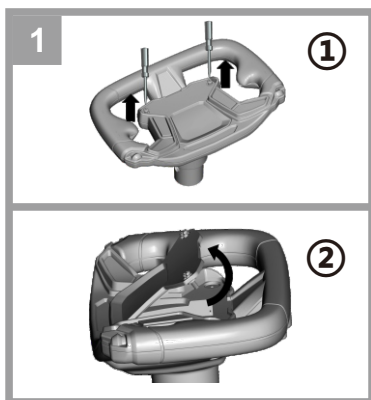

In caso di dubbio, si prega di contattare il nostro centro assistenza clienti.  
I nostri dettagli di contatto sono di seguito:

☎ 0039-0249471447

✉ clienti@aosom.it

IMPORTATO DA:  
AOSOM Italy srl  
Centro Direzionale Milanofiori  
Strada 1 Palazzo F1  
20057 Assago (MI)  
P.I.: 08567220960  
FATTO IN CINA

