

PawHut

IN221000786V03_GL

D00-167V00_D00-167V01

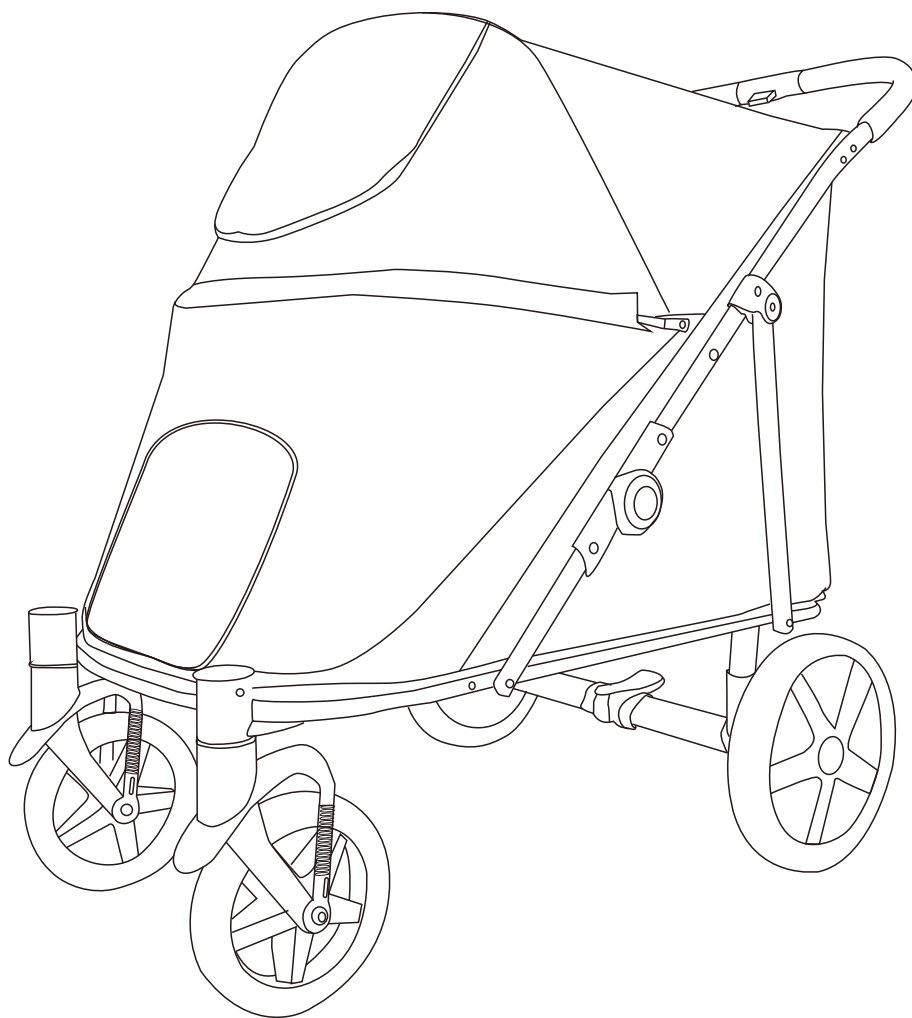

EN_ IMPORTANT, RETAIN FOR FUTURE REFERENCE: READ CAREFULLY.

FR_ IMPORTANT: A LIRE ATTENTIVEMENT ET À CONSERVER POUR CONSULTATION ULTÉRIEURE.

ES_ IMPORTANTE, LEA Y GUARDE PARA FUTURAS REFERENCIAS.

PT_ IMPORTANTE, RETER PARA REFERÊNCIA FUTURA: LEIA ATENTAMENTE.

DE_ WICHTIG! SORGFÄLTIG LESEN UND FÜR SPÄTER NACHSCHLAGEN AUFBEWAHREN.

IT_ IMPORTANTE! CONSERVARE IL PRESENTE MANUALE PER FUTURO RIFERIMENTO E LEGGERLO ATTENTAMENTE.

WARNING:Keep Away From Fire

- 1.Please read this instruction carefully before use and keep it properly for future reference. If you do not follow this instruction, the safety of pets may be affected.
- 2.Do not leave the caregiver while the product is in use.
- 3.Do not use accessories not provided by the manufacturer.
- 4.Any load attached to the handle will affect the stability of the pet stroller.
- 5.Ensure that all the locking devices are assembled before using the pet stroller.
- 6.Pets must use restraints when using.
- 7.Do not use the pet stroller in rough areas, near stoves and other dangerous areas.
- 8.Avoid use or storage in damp, cold or high temperature environment and keep away from fire or strong heat source.
- 9.Do not use it to put dangerous animals which are aggressive and destructive.

Maintenance and Care

Please check and maintain the pet stroller frequently. The cloth cover cannot be dipped and washed. When the cloth cover is cleaned, please use a brush and other cleaning instruments to clean the dirt.

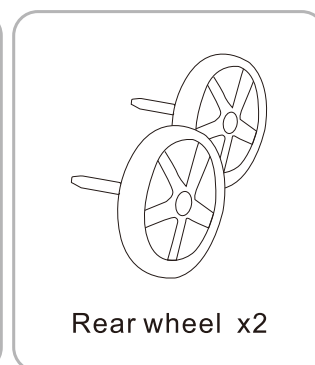
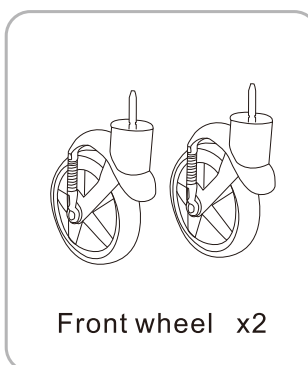
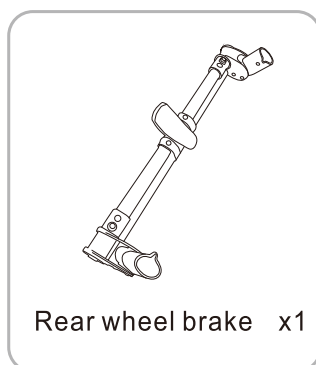
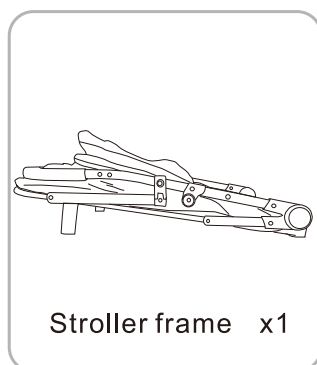
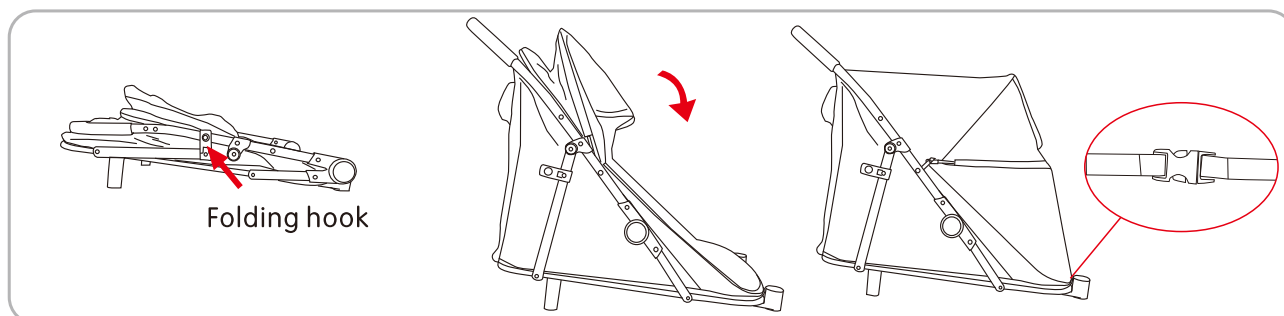
Parts**Directions for use****1.Unfolding frame**

Release the hook, hold the handlebar with both hands and lift it up until a click is heard which means the frame is fully open. After opening the frame, unfold the canopy, zip up the zipper, and fasten the latch buckle.

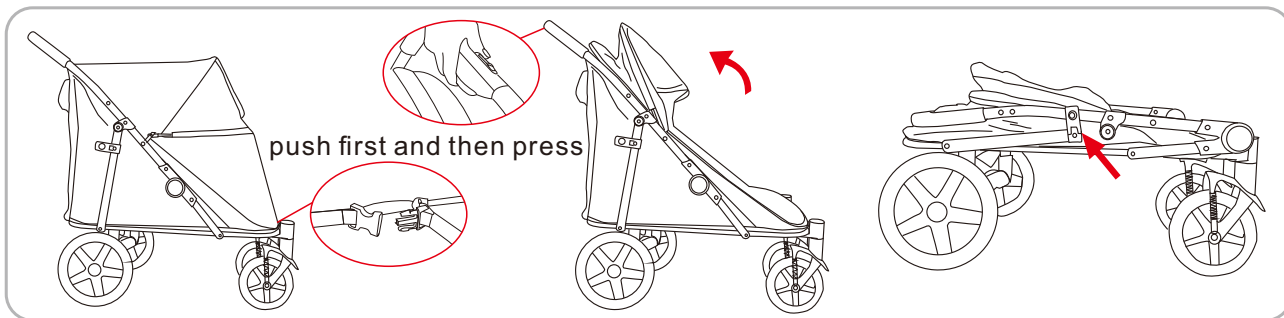

2. Folding frame

Under braking, unbuckle the latch, pull the zipper to both sides, and then fold the canopy; Hold the handlebar in one hand, push the unlock button on the handlebar to the left, and then press the closing button and press down the frame, the frame can be folded, finally hang the hook.

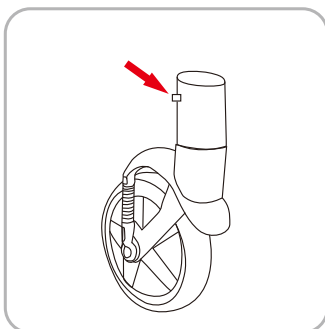
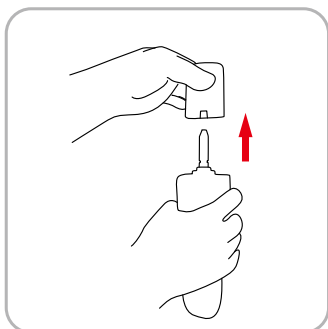

3. Install & disassemble front wheels As shown in the picture, insert the front wheel into the hole of the front wheel seat and hear the "click". Hold the removal button and pull it down, the front wheel can be removed.

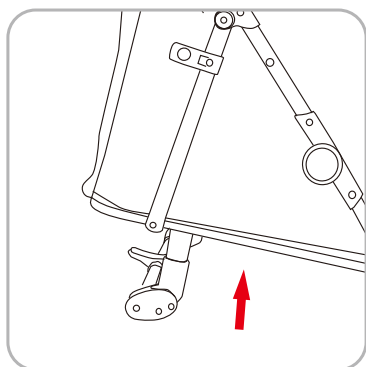
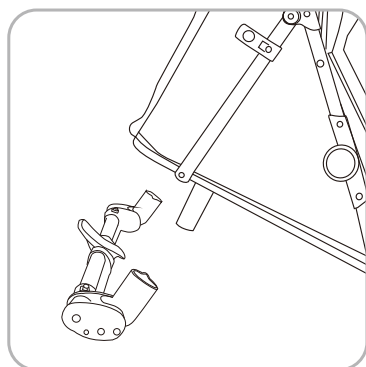

4. Install & disassemble rear wheels

As shown in the picture, put the rear wheel brake seat into the rear wheel seat first, and the left and right sides of the wheel seat shrapnel can pop out; Then put the rear wheel into the rear wheel seat hole, hear the "click". Hold the remove button and pull it out .the rear wheel can be removed.

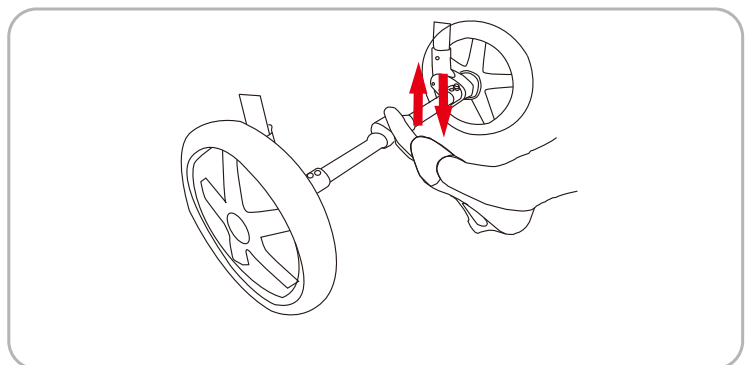
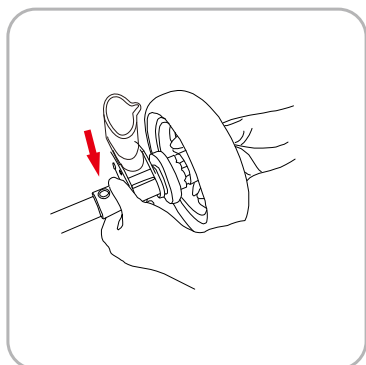
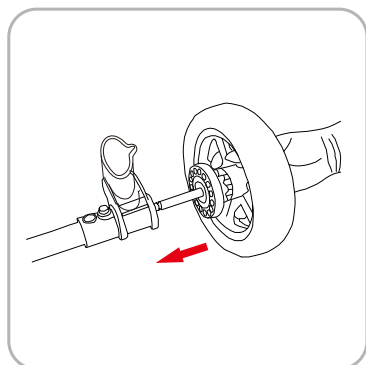

5. Use of rear wheel brake lever Press down the brake pedal, the brake works. Conversely, it can be released.

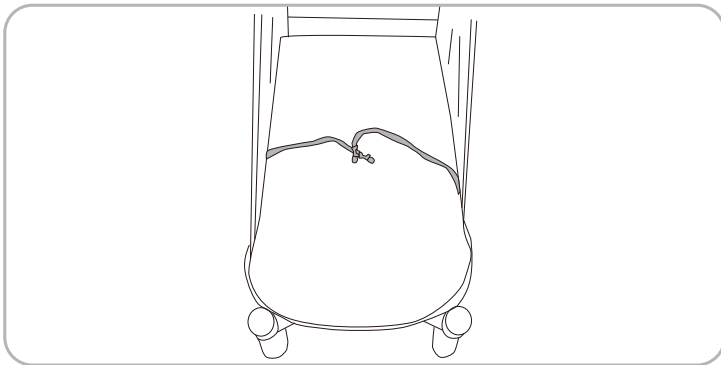

6. For pet safety belts

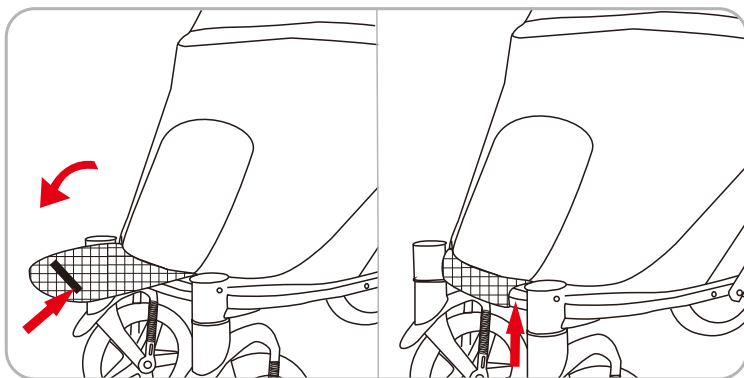

7. Usage of mesh window
Open with zipper and roll it. Can stick the velcro to the bottom.

AVERTISSEMENT : À Garder à l'Écart Du Feu

1. Prière de lire attentivement ces instructions avant l'utilisation et de les conserver pour s'y référer ultérieurement. Le non-respect de ces instructions peut affecter la sécurité des animaux domestiques.
2. Le gardien ne doit pas s'absenter pendant l'utilisation de l'appareil.
3. Ne pas utiliser d'accessoires non fournis par le fabricant.
4. La stabilité de la poussette est affectée par toute charge fixée à la poignée.
5. S'assurer que tous les dispositifs de verrouillage sont assemblés avant d'utiliser la poussette pour animaux.
6. Les animaux domestiques doivent être attachés lors de l'utilisation.
7. Ne pas utiliser la poussette dans des endroits rugueux, à proximité de foyers ou d'autres endroits dangereux.
8. Éviter d'utiliser ou de ranger la poussette dans un environnement humide, froid ou à haute température et la tenir éloignée du feu ou d'une source de chaleur intense.
9. La poussette ne doit pas être utilisée pour transporter des animaux dangereux, agressifs et nuisibles.

Maintenance et Entretien

La poussette doit être vérifiée et entretenue fréquemment. La housse en tissu ne doit pas être trempée ni lavée. Lorsque la housse en tissu doit être nettoyée, prière d'utiliser une brosse et d'autres instruments de nettoyage pour enlever la saleté.

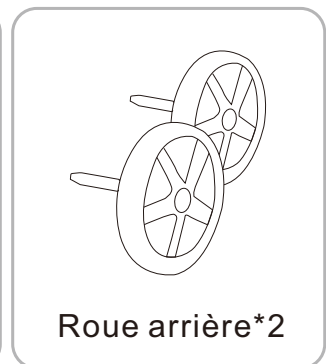
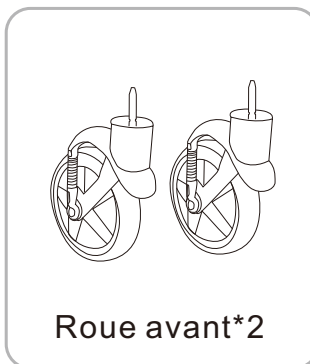
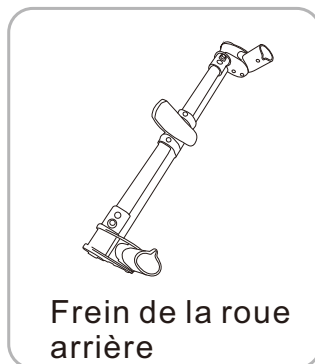
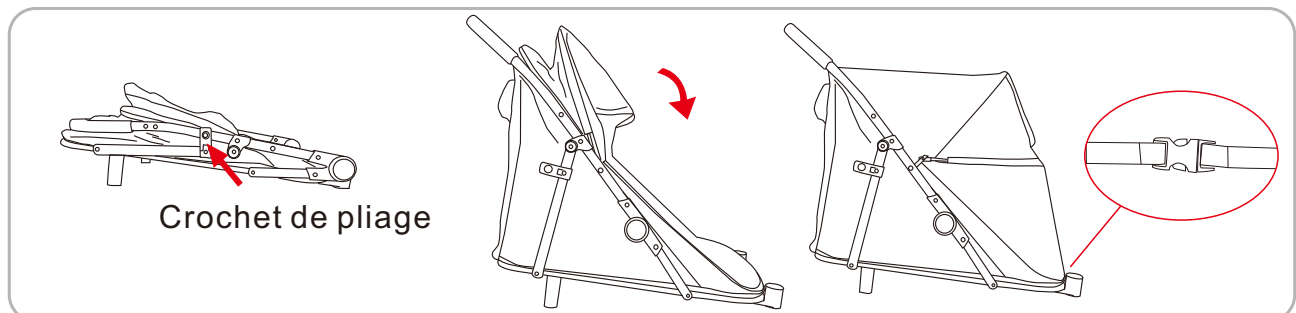
Pièces**Mode d'emploi****1. Dépliage du cadre**

Libérer le crochet, tenir le guidon à deux mains et le soulever jusqu'à ce qu'un clic se fasse entendre, indiquant que le cadre est complètement déplié. Après avoir ouvert le cadre, remonter la fermeture à glissière et attacher la boucle de verrouillage.

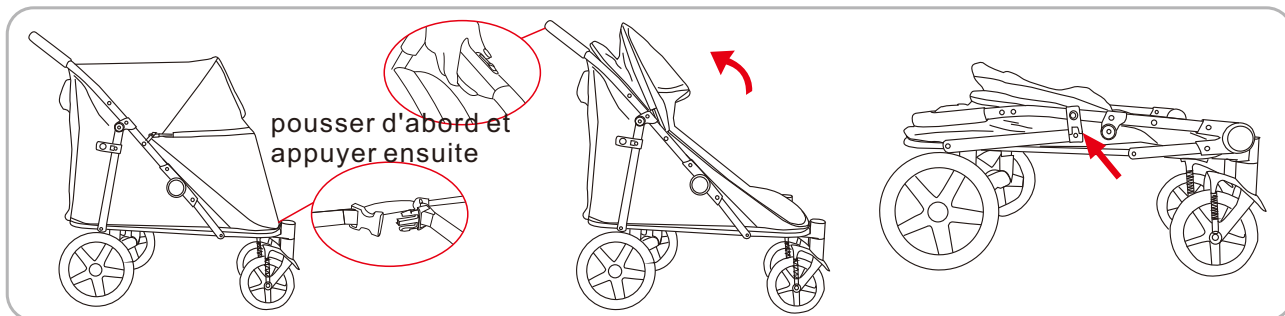

pousser d'abord et appuyer ensuite

2. cadre pliant

Tenez le guidon d'une main, poussez le bouton de déverrouillage du guidon vers la gauche, puis appuyez sur le bouton de fermeture et appuyez sur le cadre, le cadre peut être plié, et enfin accrochez le crochet.

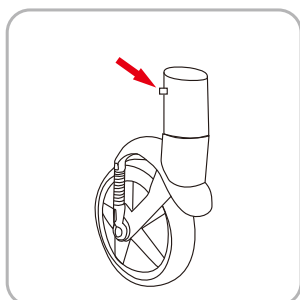
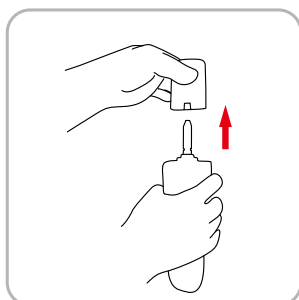

3. Montage et démontage des roues avant

Comme indiqué sur la photo, insérer la roue avant dans le trou du siège de la roue avant jusqu'à entendre le "clic". Maintenir le bouton de retrait et le tirer vers le bas, la roue avant peut être retirée.

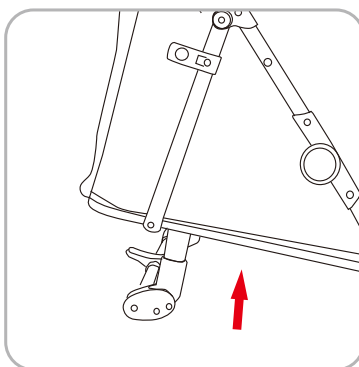
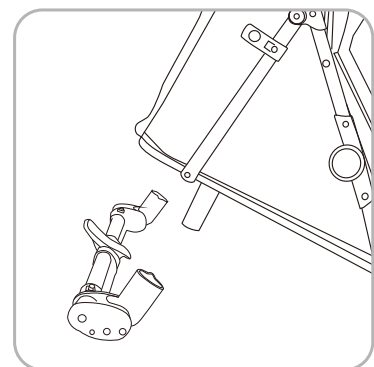

4. Montage et démontage des roues arrière

Comme indiqué sur la photo, mettre d'abord le jeu de freins de la roue arrière sur l'ensemble de la roue arrière ; les extrémités gauche et droite du jeu de roues peuvent ainsi ressortir. Ensuite, placer la roue arrière dans le trou du siège de la roue arrière jusqu'à entendre un "clic".

Maintenir le bouton de retrait et le retirer. La roue arrière peut être retirée.

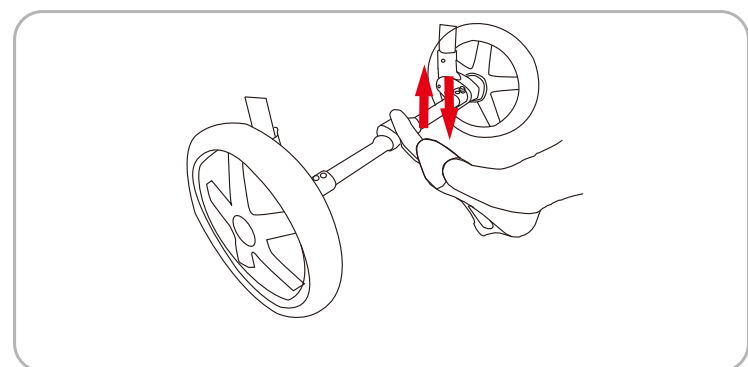
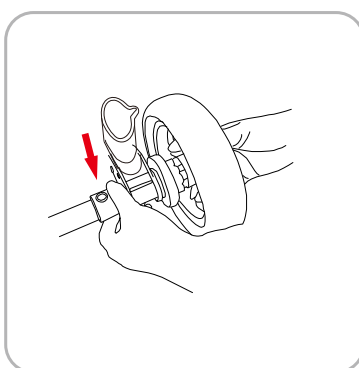
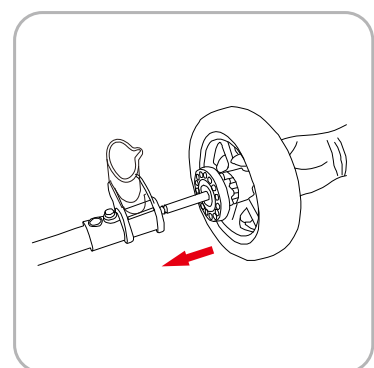

5. Utilisation du levier de frein de la roue arrière

Appuyer sur la pédale de frein, le freinage fonctionne. Inversement, il peut être relâché.

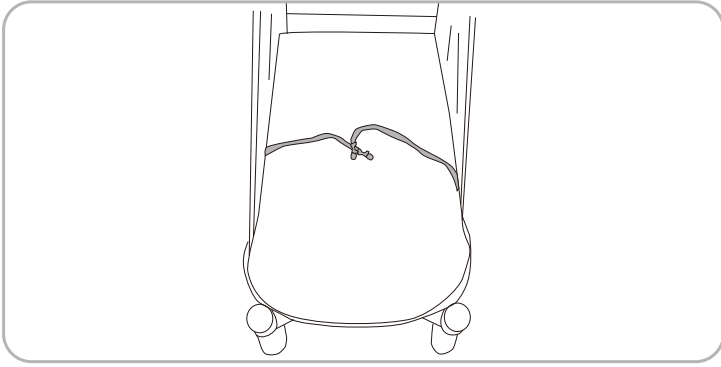

6. Ceintures de sécurité pour animaux de compagnie

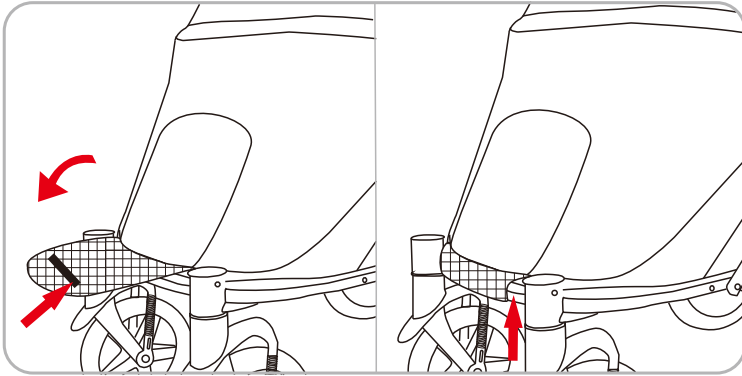

7. utilisation de la fenêtre en filet

S'ouvre à l'aide d'une fermeture à glissière et se roule. Peut coller le velcro sur le fond.

ADVERTENCIA: Mantener alejado del fuego

1. Por favor, lea atentamente estas instrucciones antes de usar el aparato y guárdelas para futuras consultas. Si no sigue estas instrucciones, la seguridad de las mascotas puede verse afectada.
2. No deje al cuidador mientras el producto está en uso.
3. No utilice accesorios no proporcionados por el fabricante.
4. Cualquier carga fijada al mango afectará la estabilidad del cochecito para mascotas.
5. Asegúrese de que todos los dispositivos de bloqueo estén montados antes de usar la silla de paseo para mascotas.
6. Los animales domésticos deben ir sujetos cuando se esté usando el producto.
7. No use el cochecito para mascotas en zonas abruptas, cerca de estufas y otras zonas peligrosas.
8. Evite el uso o el almacenamiento en ambientes húmedos, fríos o con altas temperaturas y manténgalo alejado del fuego o de fuentes de calor fuertes.
9. No lo utilice para colocar animales peligrosos que sean agresivos y destructivos.

Mantenimiento y Cuidado

Por favor, compruebe y mantenga el cochecito para mascotas con frecuencia. La funda de tela no se puede sumergir ni lavar. Cuando se limpie la cubierta de tela, por favor, utilice un cepillo y otros instrumentos de limpieza para limpiar la suciedad.

Piezas

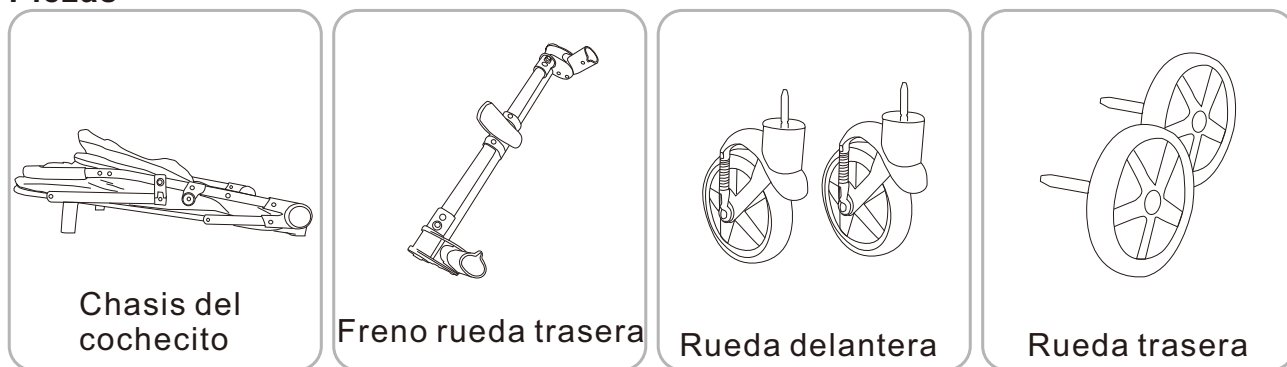

Instrucciones de uso

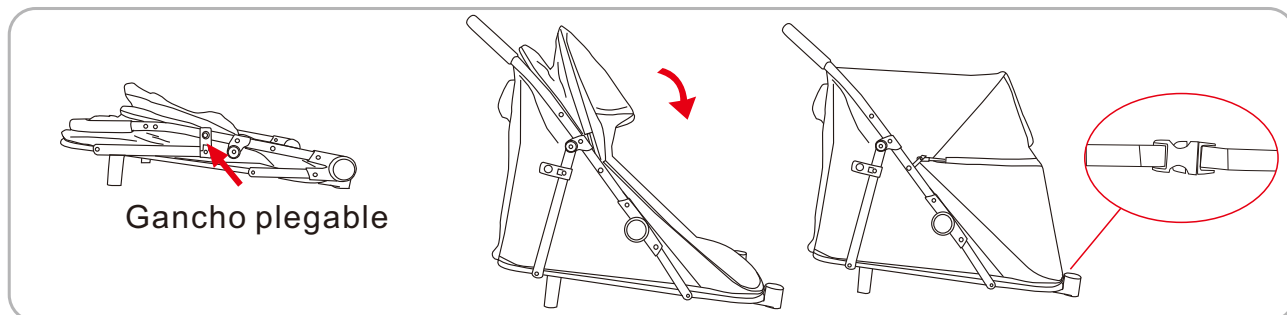

1. Despliegue del cuadro

Suelte el gancho, sujete el manillar con ambas manos y levántelo hasta escuchar un clic que significa que el cuadro está completamente abierto. Una vez abierto el cuadro, sube la cremallera y abrocha la hebilla de cierre.

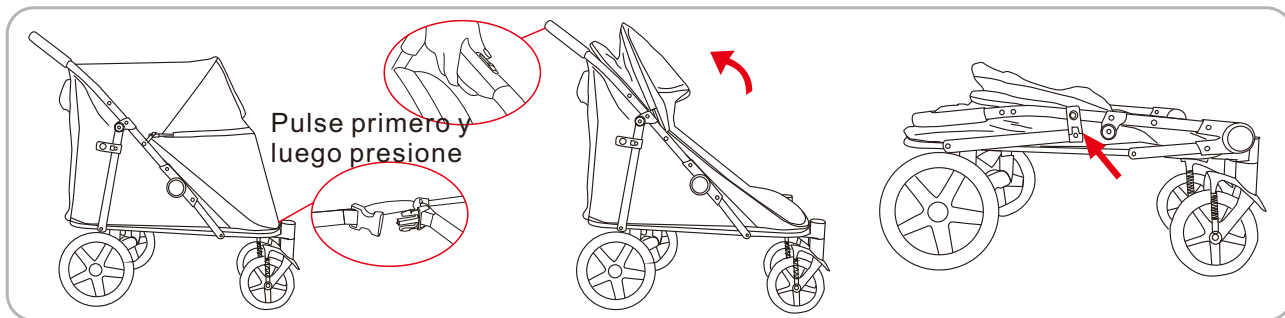

Pulse primero y luego presione

2. Bastidor plegable

Al frenar, desabroche el pestillo, tire de la cremallera hacia ambos lados y, a continuación, pliegue la capota; Sujete el manillar con una mano, pulse el botón de desbloqueo del manillar hacia la izquierda y, a continuación, pulse el botón de cierre y presione el cuadro hacia abajo, el cuadro se puede plegar, finalmente cuelgue el gancho.

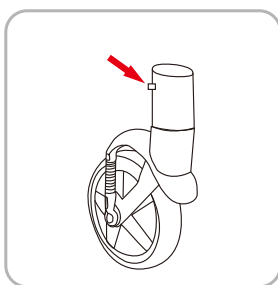
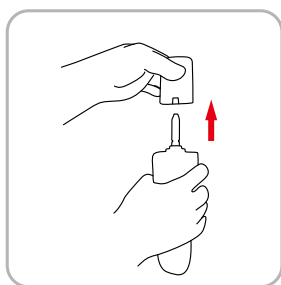

3. Instalar y desmontar las ruedas delanteras.

Como se muestra en la imagen, inserte la rueda delantera en el orificio de la rueda delantera y escuchará un "clic". Mantenga presionado el botón de extracción y tire de él hacia abajo, entonces la rueda delantera quedará desbloqueada.

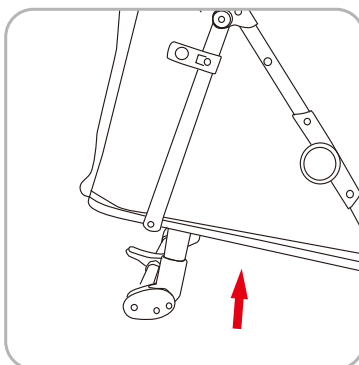
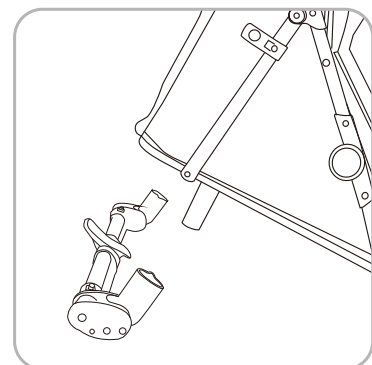

4. Instalar y desmontar las ruedas traseras.

Como se muestra en la imagen, coloque el soporte de la rueda trasera en el marco, luego inserte la rueda derecha e izquierda y bloquee con el freno. Luego coloque el soporte de la rueda trasera en el orificio del cochecito hasta que escuche el "clic".

Para quitar el soporte de toda la parte trasera, presione el bloqueo en la parte central, tire de él y retire el soporte.

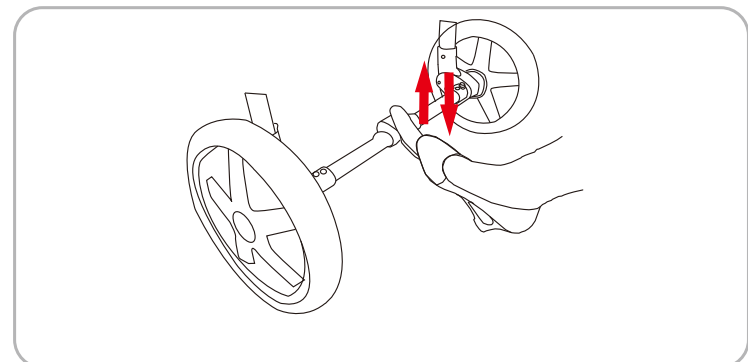
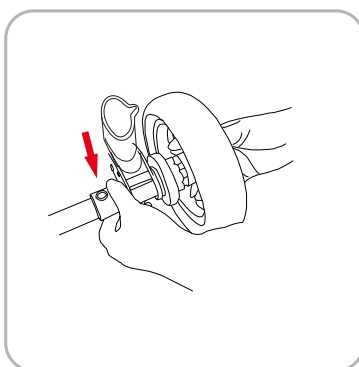
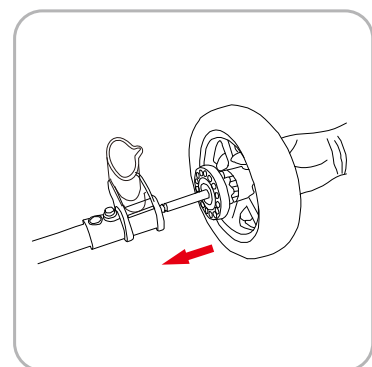

5. Uso de la palanca de freno de la rueda trasera

A pisar el pedal del freno, el freno funciona y queda accionado. A la inversa se desbloquea.

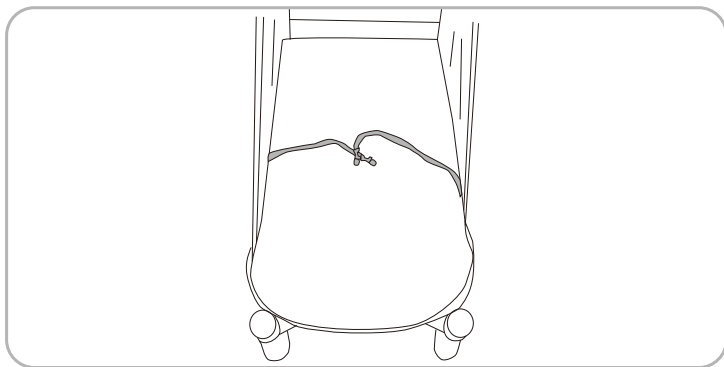

6. Para los cinturones de seguridad para mascotas.

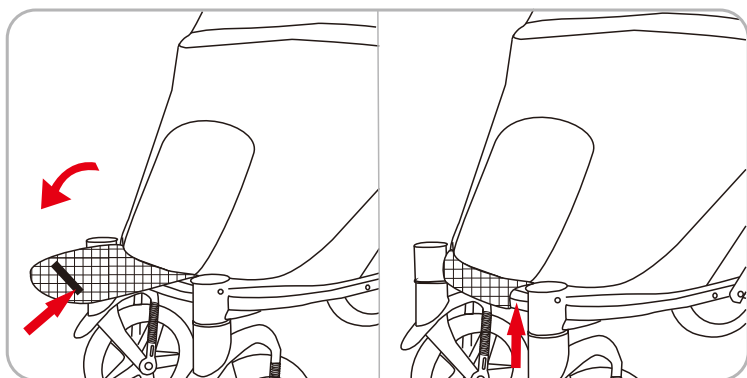

7. Uso de la ventana de malla

Se abre con cremallera y se enrolla. Puede pegar el velcro en la parte inferior.

AVISO: Mantenha-se Longe do Fogo

1. Por favor leia esta instrução cuidadosamente antes de usar e guarde-a devidamente para referência futura. Se não seguir estas instruções, a segurança dos animais de estimação pode ser afetada.
2. Não deixe o prestador de cuidados enquanto o produto estiver em uso.
3. Não utilize acessórios não fornecidos pelo fabricante.
4. Qualquer carga presa à pega afetará a estabilidade do carrinho do animal.
5. Certifique-se de que todos os dispositivos de bloqueio estão montados antes de usar o carrinho de passeio para animais domésticos.
6. Animais de estimação devem usar trelas.
7. Não use o carrinho de passeio em áreas ásperas, perto de fogões e outras áreas perigosas.
8. Evitar o uso ou armazenamento em ambientes húmidos, frios ou de alta temperatura e manter longe de fogo ou fonte de calor forte.
9. Não o utilize para colocar animais perigosos que sejam agressivos e destrutivos.

Manutenção e Cuidados

Por favor, verifique e mantenha o carrinho de passeio frequentemente. A cobertura do pano não pode ser mergulhada e lavada. Quando a cobertura do pano for limpa, por favor use uma escova e outros instrumentos de limpeza para limpar a sujidade.

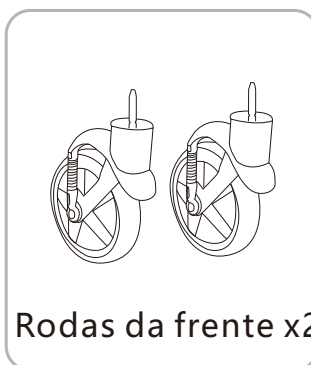
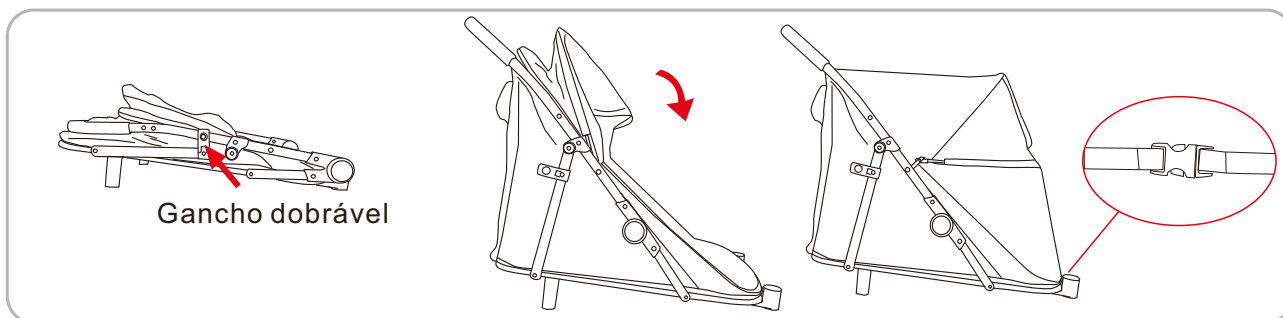
Partes**Instruções de utilização****1. Desdobramento da estrutura**

Solte o gancho, segure o guidador com ambas as mãos e levante-o até ouvir um clique o que significa que a estrutura está totalmente aberta. Após a abertura da estrutura, fechar o fecho de correr e apertar a fivela de fecho.

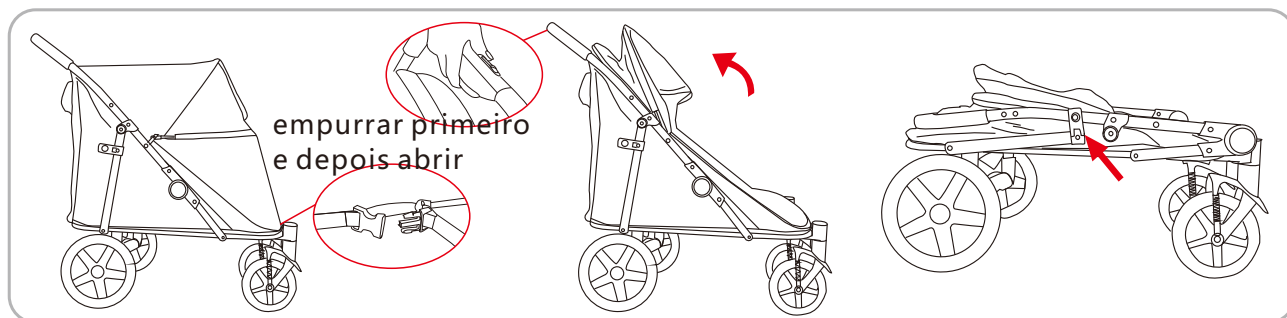

empurrar primeiro e depois abrir

2. quadro dobrável

Durante a travagem, desapertar o fecho, puxar o fecho para ambos os lados e, em seguida, dobrar a capota; segurar o guiador com uma mão, premir o botão de desbloqueio no guiador para a esquerda e, em seguida, premir o botão de fecho e premir a armação para baixo, a armação pode ser dobrada e, finalmente, pendurar o gancho.

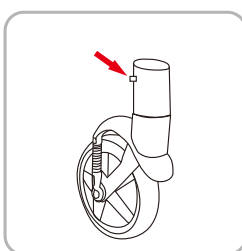
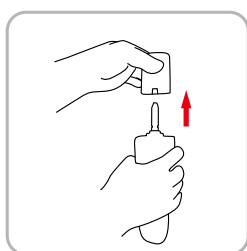

3. Instalar e desmontar as rodas frontais

Como mostrado na figura, inserir a roda dianteira no orifício do assento da roda dianteira até ouvir o "clique".

Segurar o botão de remoção e puxá-lo para baixo, e a roda dianteira pode ser removida.

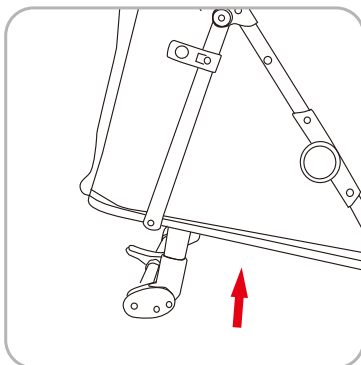
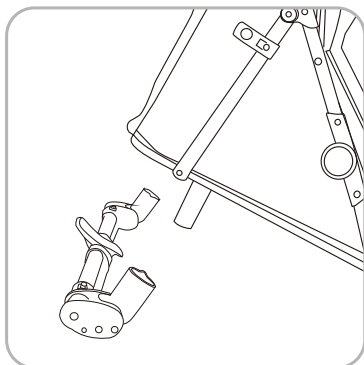

4. Instalar e desmontar as rodas traseiras

Como se mostra na imagem, coloque o suporte roda traseira na estrutura, em seguida insira a roda direita e a esquerda e bloqueie utilizando o travão. Em seguida colocar o suporte da roda traseira no orifício do carrinho de passeio até ouvir o "clique".

Para retirar o suporte da toda traseira prima o travão na parte central, puxe-o para fora e remova o suporte.

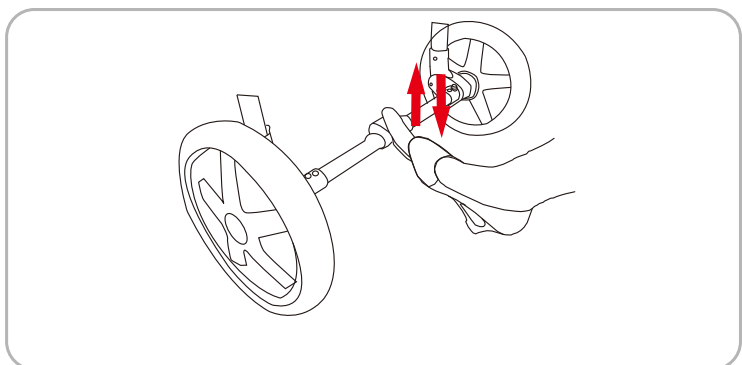
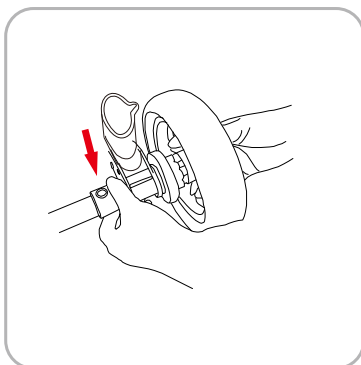
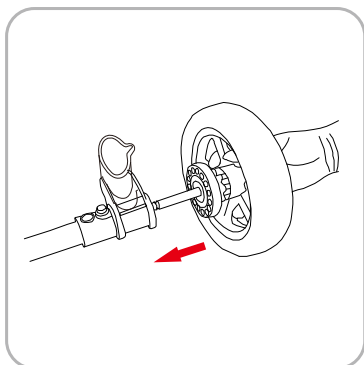

5. Utilização da alavanca e do travão da roda traseira

Carregar no pedal do travão, o travão funciona.

Pelo contrário, pode ser libertado.

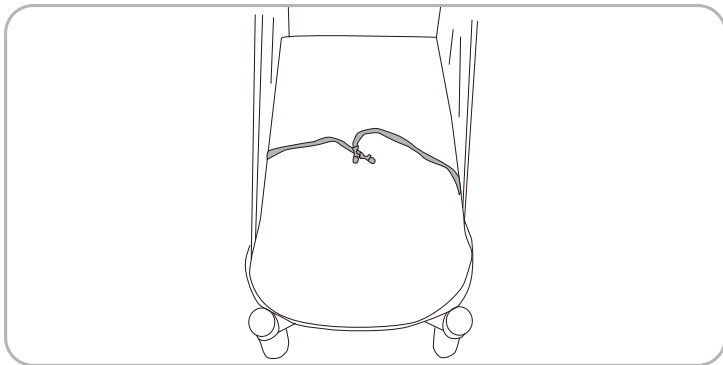

6. Cinto de segurança de animais de estimação.

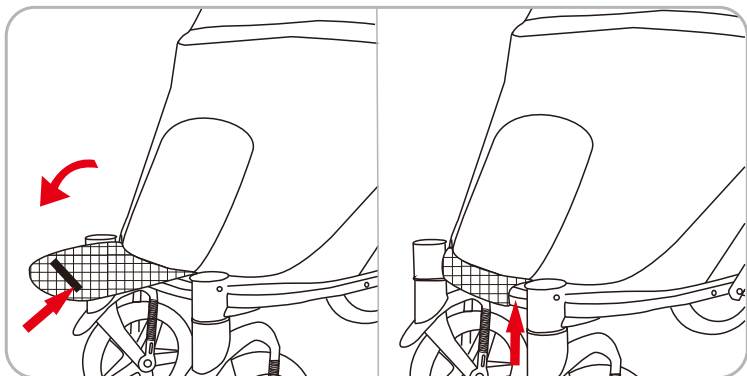

7. Utilização da janela de rede

Abrir com fecho de correr e enrolar. Pode colar o velcro na parte inferior.

WARNUNG: Von Feuer fernhalten

1. Bitte lesen Sie diese Anweisung sorgfältig durch und bewahren Sie sie zum späteren Nachschlagen auf. Wenn Sie diese Anweisung nicht befolgen, kann die Sicherheit von Haustieren beeinträchtigt werden.
2. Während der Verwendung des Produkts darf sich die Betreuungsperson nicht entfernen.
3. Verwenden Sie kein Zubehör, das nicht vom Hersteller bereitgestellt wird.
4. Jede an der Lenkstange befestigte Last beeinträchtigt die Stabilität des Hundebuggys.
5. Stellen Sie sicher, dass alle Verriegelungsvorrichtungen vor der Verwendung des Hundebuggys montiert sind.
6. Haustiere müssen bei der Verwendung angeschnallt sein.
7. Verwenden Sie den Hundebuggy nicht in rauen Gegenden, in der Nähe von Öfen oder anderen gefährlichen Bereichen.
8. Verwenden oder lagern Sie ihn nicht in feuchten, kalten oder heißen Umgebungen und halten Sie ihn von Feuer oder starken Wärmequellen fern.
9. Verwenden Sie ihn nicht für gefährliche Tiere, die aggressiv und zerstörerisch sind.

Wartung und Pflege

Bitte überprüfen und warten Sie den Hundebuggy regelmäßig. Das Verdeck kann nicht getaucht und gewaschen werden. Wenn Sie das Verdeck reinigen, verwenden Sie bitte eine Bürste und andere Reinigungsmittel, um den Schmutz zu entfernen.

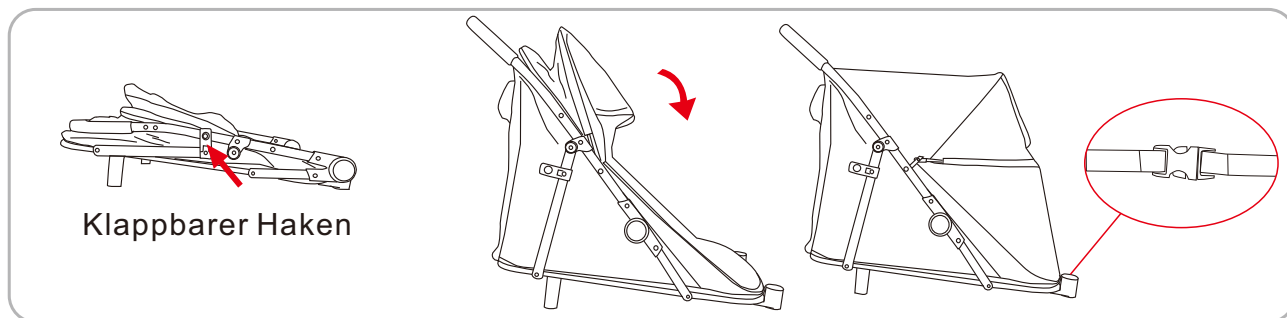
Teile**Gebrauchsanweisung****1. Aufklappen des Rahmens**

Geben Sie den Haken frei, halten Sie den Lenker mit beiden Händen fest und heben Sie ihn hoch, bis ein Klicken zu hören ist, was bedeutet, dass der Rahmen vollständig geöffnet ist. Nachdem Sie den Rahmen geöffnet haben, ziehen Sie den Reißverschluss zu, und schließen Sie die Verschlussschnalle.

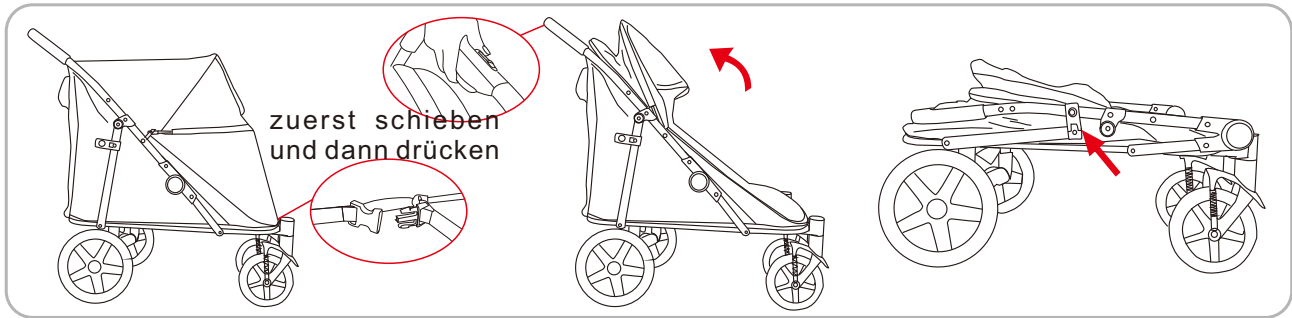

zuerst schieben
und dann drücken

2. faltbarer Rahmen

Unter Bremsen, lösen Sie die Verriegelung, ziehen Sie den Reißverschluss zu beiden Seiten, und dann falten Sie das Verdeck; Halten Sie den Lenker in einer Hand, drücken Sie die Entriegelungstaste auf dem Lenker nach links, und drücken Sie dann die Schließstaste und drücken Sie den Rahmen nach unten, kann der Rahmen gefaltet werden, schließlich hängen Sie den Haken.

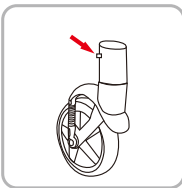
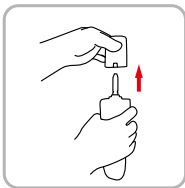

3. Einbau & Demontage der Vorderräder

Fügen Sie, wie in der Abbildung gezeigt, das Vorderrad in das Loch des Vorderradsitzes ein und hören Sie das „Klicken“.

Halten Sie die Taste zum Entfernen gedrückt und ziehen Sie sie nach unten. Das Vorderrad kann entfernt werden.

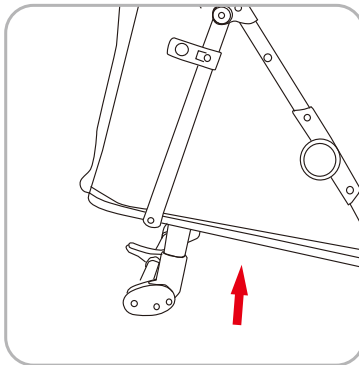
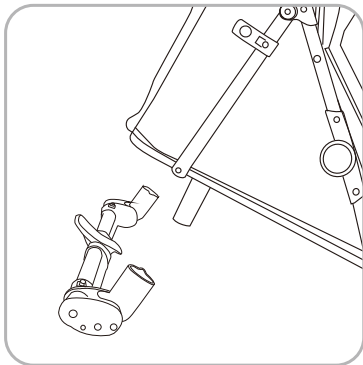

4. Einbau & Demontage der Hinterräder

Setzen Sie, wie in der Abbildung gezeigt, zuerst den hinteren Radbremsensitz in den hinteren Radsitz ein, und die linke und rechte Seite des Radsitzes kann herausragen; setzen Sie dann das Hinterrad in das Loch des hinteren Radsitzes ein, hören Sie das „Klicken“.

Halten Sie die Taste zum Entfernen gedrückt und ziehen Sie sie heraus. Das Hinterrad kann entfernt werden.

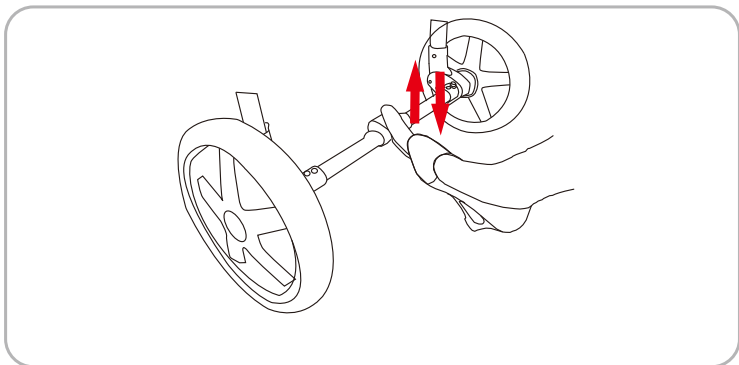
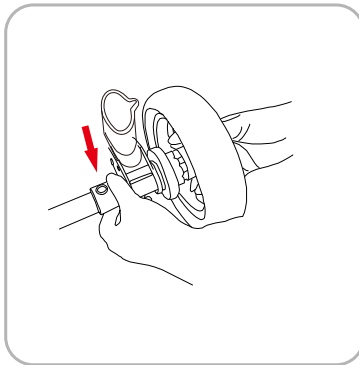
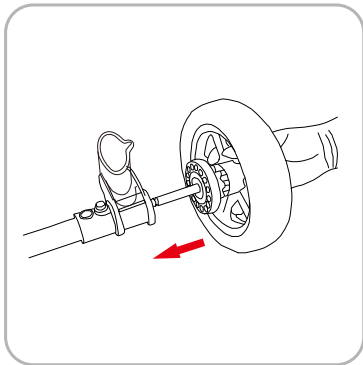

5. Verwendung des Hinterradbremshhebels

Drücken Sie das Bremspedal nach unten, die Bremse arbeitet.

Umgekehrt kann sie auch freigegeben werden.

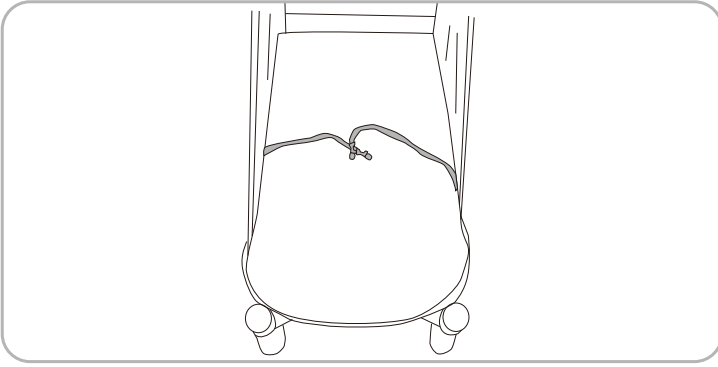

6. Für Sicherheitsgurte für Haustiere

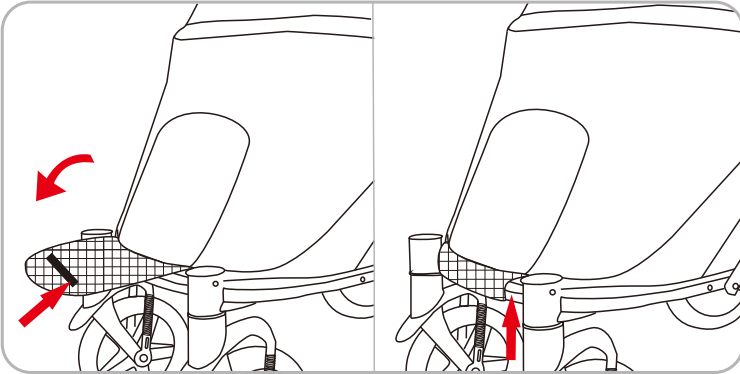

7. die Verwendung des Netzfensters

Mit Reißverschluss öffnen und aufrollen. Kann den Klettverschluss an der Unterseite kleben.

AVVERTENZA: Tenere lontano dal fuoco

1. Si prega di leggere attentamente le presenti istruzioni prima dell'uso e di conservarle per future consultazioni. Se non si seguono queste istruzioni, la sicurezza degli animali domestici potrebbe essere compromessa.

2. Non lasciare andare la persona che assiste quando il prodotto è in uso.

3. Non utilizzare accessori non forniti dal produttore.

4. Qualsiasi carico attaccato alla maniglia influisce sulla stabilità del passeggino.

5. Assicurarsi che tutti i dispositivi di bloccaggio siano montati prima di utilizzare il passeggino.

6. Gli animali domestici devono essere trattenuti durante l'uso.

7. Non utilizzare il passeggino in zone impervie, vicino a stufe o altre aree pericolose.

8. Evitare l'uso o lo stoccaggio in ambienti umidi, freddi o ad alta temperatura e tenerlo lontano dal fuoco o da fonti di calore forte.

9. Non utilizzarlo per animali pericolosi, aggressivi e distruttivi.

Manutenzione e Cura

Controllare e mantenere frequentemente il passeggino per animali domestici. Il rivestimento in tessuto non può essere immerso in liquido e lavato. Quando si pulisce il rivestimento in tessuto, utilizzare una spazzola e altri strumenti di pulizia per pulire lo sporco.

Parti di ricambio



Istruzioni per l'uso

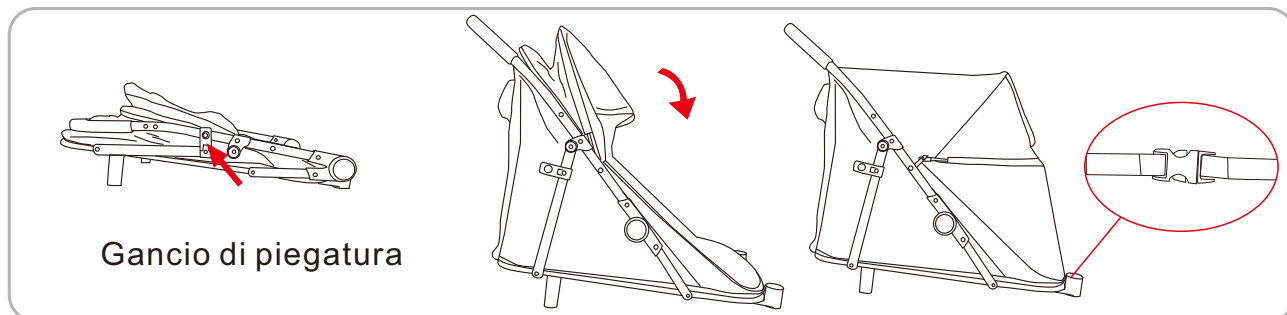

1. Aprire il telaio

Rilasciare il gancio, afferrare il manubrio con entrambe le mani e sollevarlo fino a quando non si sente un clic, il che significa che il telaio è completamente aperto. Dopo aver aperto il telaio, chiudere la cerniera e allacciare la fibbia di chiusura.

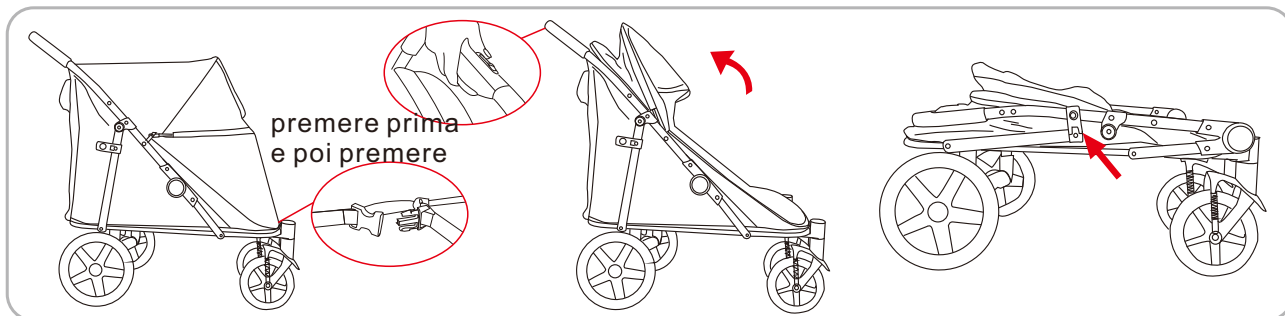

2. Telaio pieghevole

In frenata, sganciare la chiusura, tirare la cerniera su entrambi i lati, quindi ripiegare la cappottina; tenere il manubrio con una mano, spingere il pulsante di sblocco sul manubrio a sinistra, quindi premere il pulsante di chiusura e premere il telaio, il telaio può essere ripiegato, infine appendere il gancio.

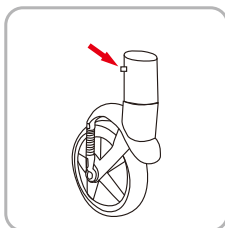
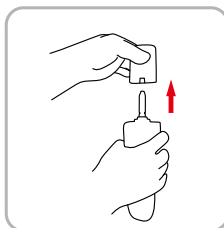

3. Installare e smontare le ruote anteriori

Come mostrato nell'immagine, inserire la ruota anteriore nel foro della sede della ruota anteriore e si sente un "clic".

Tenere il pulsante di rimozione e tirarlo verso il basso, la ruota anteriore può essere rimossa.

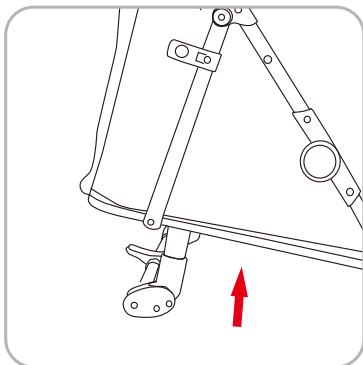
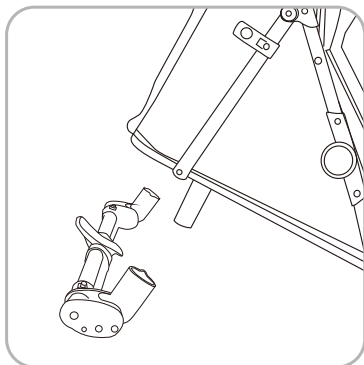

4. Installare e smontare le ruote posteriori

Come mostrato nell'immagine, inserire la sede del freno della ruota posteriore nella sede della ruota posteriore, e ai lati destro e sinistro della sede della ruota le teste a molla possono spuntare fuori; e poi inserire la ruota posteriore nel foro della sede della ruota posteriore e si sente un clic. Tenere il pulsante di rimozione e tirarlo fuori. La ruota posteriore può essere rimossa.

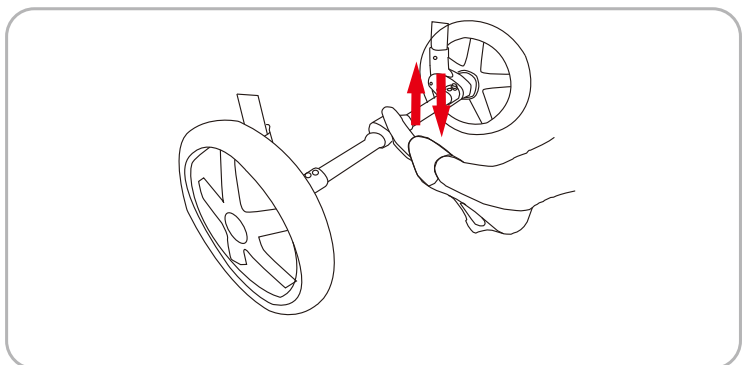
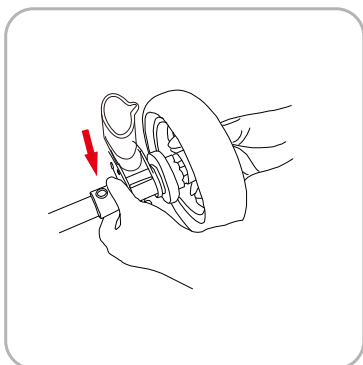
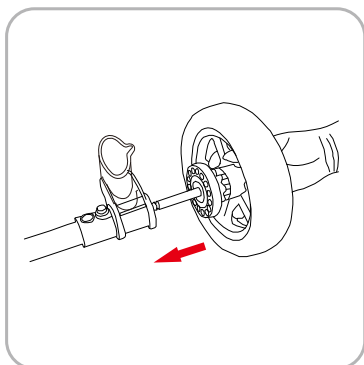

5. Uso della leva del freno della ruota posteriore

Premere il pedale del freno, il freno funziona.

Viceversa, è possibile rilasciarlo.

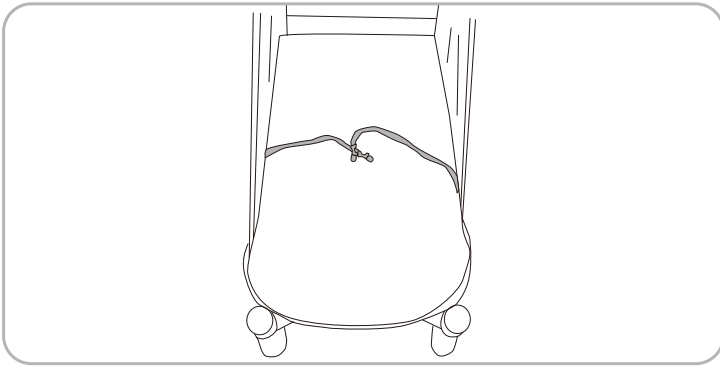

6. Per le cinture di sicurezza per animali domestici

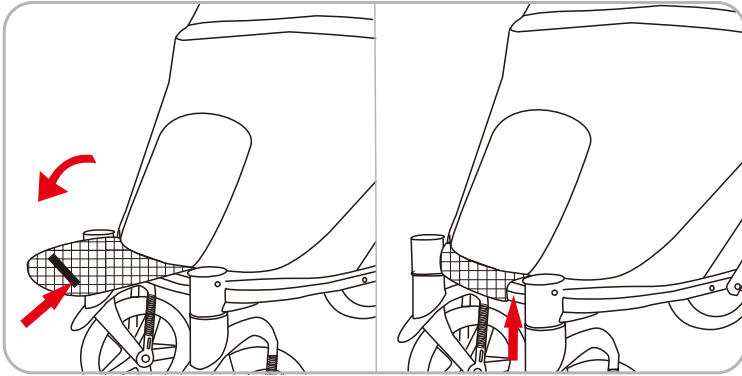

7. Uso della finestra a rete

Si apre con la cerniera e si arrotola. Può essere attaccato al fondo con il velcro.

If you have any questions, please contact our customer care center, Our contact details are below:

US

 001-877-644-9366

 customerservice@aosom.com

Imported by Aosom LLC
27150 SW Kinsman Rd Wilsonville, OR 97070 USA
MADE IN CHINA

If you have any questions, please contact our customer care center, Our contact details are below:

CA

 416-792-6088

 customerservice@aosom.ca

Imported by Aosom Canada Inc.
7270 Woodbine Avenue, Unit 307, Markham,
Ontario Canada L3R 4B9
MADE IN CHINA

Si vous avez la moindre question, veuillez contacter notre centre d'assistance à la clientèle, Nos coordonnées sont les suivantes:

 416-792-6088

 customerservice@aosom.ca

Importé par Aosom Canada Inc.
7270 Woodbine Avenue, unité 307,
Markham, Ontario Canada L3R 4B9
FABRIQUÉ EN CHINE

If you have any questions, please contact our customer care center, Our contact details are below:

UK

 0044-800-240-4004

 enquiries@mhstar.co.uk

IMPORTER ADDRESS:
MH STAR UK LTD
Unit 27, Perivale Park,
Horsenden lane South
Perivale, UB6 7RH
MADE IN CHINA

Si vous avez la moindre question, veuillez contacter notre centre d'assistance à la clientèle, Nos coordonnées sont les suivantes:

FR

 0033-1-84166106

 aosom@mhfrance.fr

Importé par/Fabricant/REP:
MH FRANCE
2 Rue Maurice Hartmann
92130 Issy Les Moulineaux
France
FABRIQUÉ EN CHINE

Wenn Sie Fragen haben, wenden Sie sich bitte an unser Kundendienstzentrum, Unsere Kontaktdaten stehen unten:

DE

 0049-0(40)-88307530

 service@aosom.de

ADRESSE DES IMPORTEURE/Hersteller/REP:
MH Handel GmbH
Wendenstraße 309
D-20537 Hamburg
Germany
IN CHINA HERGESTELLT

In caso di dubbio, si prega di contattare il nostro centro assistenza clienti, I nostri dettagli di contatto sono di seguito:

IT

 0039-0249471447

 clienti@aosom.it

IMPORTATO DA/Produttore/REP:
AOSOM Italy srl
Centro Direzionale Milanofiori
Strada 1 Palazzo F1
20057 Assago (MI)
P.I.: 08567220960
FATTO IN CINA

Si tiene alguna pregunta, comuníquese con nuestro Centro de Atención al Cliente, Nuestros datos de contacto son los siguientes:

ES

 0034-931294512

 atencioncliente@aosom.es

IMPORTADOR/Fabricante/REP:
SPANISH AOSOM, S.L.
C/ROC GROS, N°15.08550, ELS HOSTALET DE
BALENYÀ, SPAIN.
B66295775
HECHO EN CHINA

Se tiver alguma dúvida, por favor contacte o nosso Centro de Atendimento ao Cliente, Os nossos dados de contacto são os seguintes:

PT

 0034-931294512

 info@aosom.pt.

IMPORTADOR/Fabricante/REP:
SPANISH AOSOM, S.L.
C.ROC GROS N.15, 08550. ELS HOSTALET DE
BALENYÀ
FEITO NA CHINA



FR

**DONNEZ
OU
RECYCLEZ**



ASSOCIATION

OU



LIVRAISON

OU



DÉCHÈTERIE

Adresses sur quefairedemesdechets.fr