

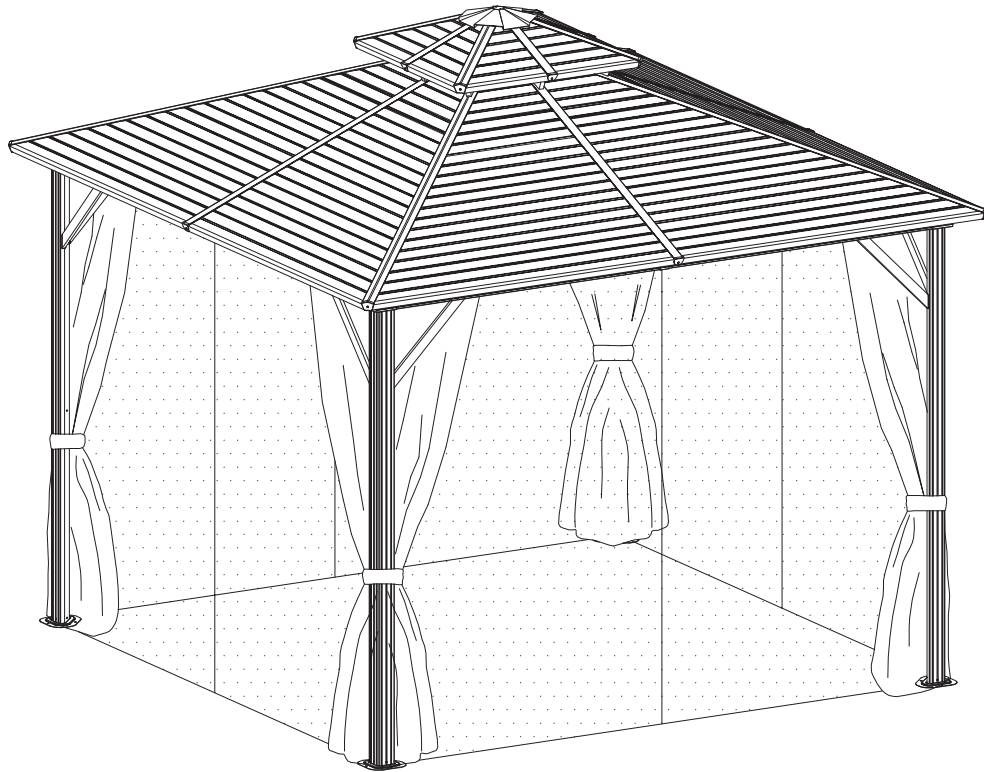

IN221000799V01_GL

84C-145V01



EN_ Assembly video please scan the QR code.
FR_ Vidéo d'assemblage, veuillez scanner le code QR.
ES_ Montaje video scannen Sie bitte den QR-Code ein.
PT_ Vídeo de montagem por favor digitalizar o código QR.
DE_ Video de montaje, escanea el código QR.
IT_ Scansionare il codice QR per il Video di Assemblaggio

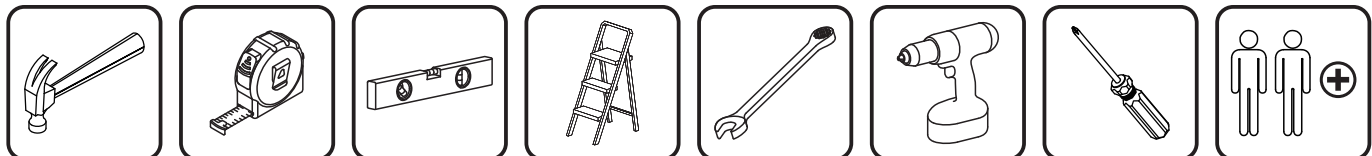

Tools Recommended

EN_ IMPORTANT, RETAIN FOR FUTURE REFERENCE: READ CAREFULLY.

FR_ IMPORTANT: A LIRE ATTENTIVEMENT ET À CONSERVER POUR CONSULTATION ULTÉRIEURE.

ES_ IMPORTANTE, LEA Y GUARDE PARA FUTURAS REFERENCIAS.

PT_ IMPORTANTE, RETER PARA REFERÊNCIA FUTURA: LEIA ATENTAMENTE.

DE_ WICHTIG! SORGFÄLTIG LESEN UND FÜR SPÄTER NACHSCHLAGEN AUFBEWAHREN.

IT_ IMPORTANTE! CONSERVARE IL PRESENTE MANUALE PER FUTURO RIFERIMENTO E LEGGERLO ATTENTAMENTE.

EN

Dear customer,

Thank you for purchasing this product. So that your appliance serves you well, please read all the instructions in this user's manual. If you have any questions, please contact our customer care center, Our contact details are below:

FR

Cher client,

Nous vous remercions d'avoir acheté ce produit. Afin que vous puissiez profiter pleinement de votre appareil, veuillez lire toutes les instructions de ce manuel d'utilisation. Si vous avez la moindre question, veuillez contacter notre centre d'assistance à la clientèle, Nos coordonnées sont les suivantes:

DE

Sehr geehrter Kunde,

Vielen Dank, dass Sie dieses Produkt erworben haben. Damit Ihr Gerät Ihnen gute Dienste leistet, lesen Sie bitte alle Hinweise in diesem Benutzerhandbuch. Wenn Sie Fragen haben, wenden Sie sich bitte an unser Kundendienstzentrum, Unsere Kontaktdaten stehen unten:

ES

Queridos clientes,

Gracias por comprar este producto. Para que su electrodoméstico le sirva mejor, lea todas las instrucciones de este manual del usuario. Si tiene alguna pregunta, comuníquese con nuestro Centro de Atención al Cliente, Nuestros datos de contacto son los siguientes:

PT

Caros clientes,











Obrigado por adquirir este produto. Para que o seu aparelho o sirva melhor, leia todas as instruções deste manual do utilizador. Se tiver alguma dúvida, por favor contacte o nosso Centro de Atendimento ao Cliente, Os nossos dados de contacto são os seguintes:







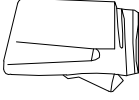
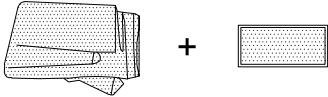

IT





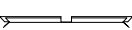
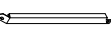



Caro Cliente,



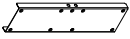

Grazie per aver acquistato questo prodotto. Per servirti meglio con questo apparecchio ti prego di leggere tutte le istruzioni in presente manuale utente. In caso di dubbio, si prega di contattare il nostro centro assistenza clienti, I nostri dettagli di contatto sono di seguito:

Country	 Phone	 Email
US	001-877-644-9366	customerservice@aosom.com
CA	416-792-6088	customerservice@aosom.ca
UK	0044-800-240-4004	enquiries@mhstar.co.uk
DE	0049-0(40)-88307530	service@aosom.de
FR	0033-1-84166106	aosom@mhfrance.fr
ES&PT	0034-931294512	atencioncliente@aosom.es
IT	0039-0249471447	clienti@aosom.it

Carton-1/3	No	Reference Picture	Part	Qty
	1		A	4
	2		B	4
	3		B1	4
	4		E	4
	5		J	4
	6		K	4
	7		K1	4
	8		L	1
	9		M	1
	10		T	4
	11		T1	4+1
	12		1,2,3,4, 5	209
	13			2

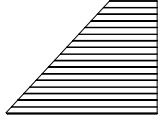
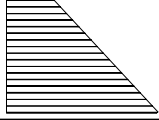
Carton-2/3	No	Reference Picture	Part	Qty
	1		E1	4
	2		F1	4
	3		F2	4
	4		G1	4
	5		G2	4
	6		G3	4
	7		D1	4
	8		D2	4
	9		H1	4
	10		H2	4
	11		H	4

Carton-2/3	No	Reference Picture	Part	Qty
	12		N	12
	13		N1	8
	14		P	4
	15		U	96
	16		V	4
	17		Y	16
	18		W	12
	19		8	12

Carton-3/3	No	Reference Picture	Part	Qty
	1		Q1	4
	2		Q2	4
	3		R1	4
	4		R2	4
	5		S1	4
	6		S2	4



A 4x



B 4x



B1 4x

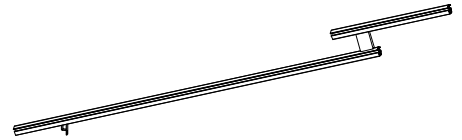

E 4x



E1 4x



F1 4x



F2 4x



G1 4x



G2 4x



G3 4x



D1 4x

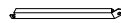

D2 4x



H1 4x

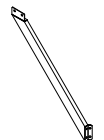

H2 4x



H 4x

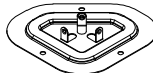

J 4x



K 4x



K1 4x

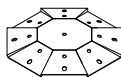

L 1x

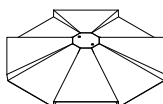

M 1x



N 12x



N1 8x

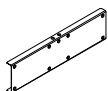

P 4x

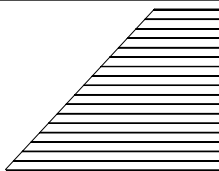



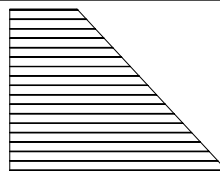









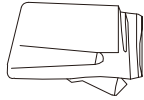
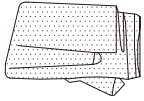



Q1 4x



Q2 4x



R1 4x

 (R2) 4x	 (S1) 4x	 (S2) 4x	 (T) 4x
 +  (T1) 4x+1x	 (U) 96x	 (V) 4x	 (Y) 16x
 (W) 12x	S4  1x	 1x	
 M6x15 (1) 104x+ 4	 M6x10 (2) 32x+ 1	 M5x12 (3) 48x+ 2	 ST4.8x12 (4) 24x+ 2
 (5) 1x	 (8) 12x		

<1>

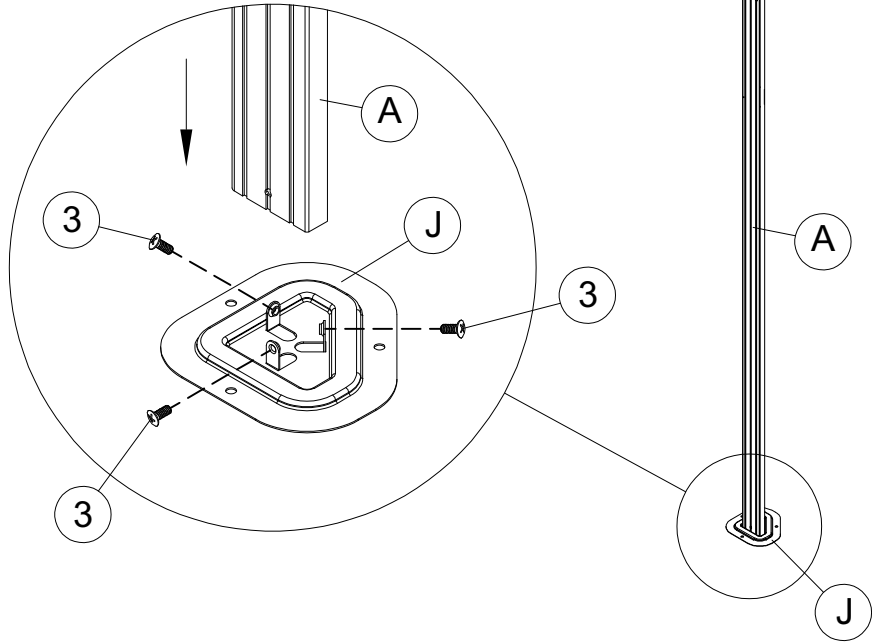
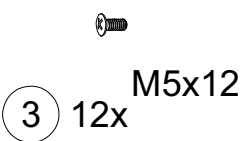
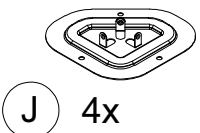
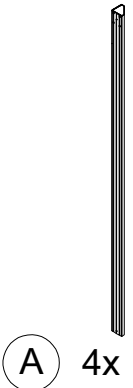

<2>

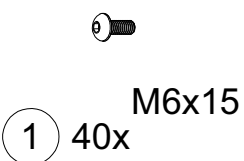
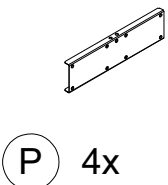
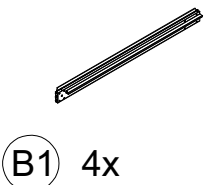
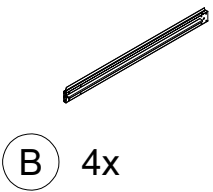

EN: This is divided into up and down directions, and the position of the hole refers to the enlarged view.
 DE: Dies ist in Aufwärts- und Abwärtsrichtung unterteilt, und die Position des Lochs bezieht sich auf die vergrößerte Ansicht.
 ES: Esto se divide en direcciones hacia arriba y hacia abajo, y la posición del orificio se refiere a la vista ampliada.
 FR: Ceci est divisé en directions de haut en bas, et la position du trou se réfère à la vue agrandie.
 IT: Questo e' diviso in posizione verso il basso e verso l'alto, e la posizione del foro si riferisce alla visuale allargata.

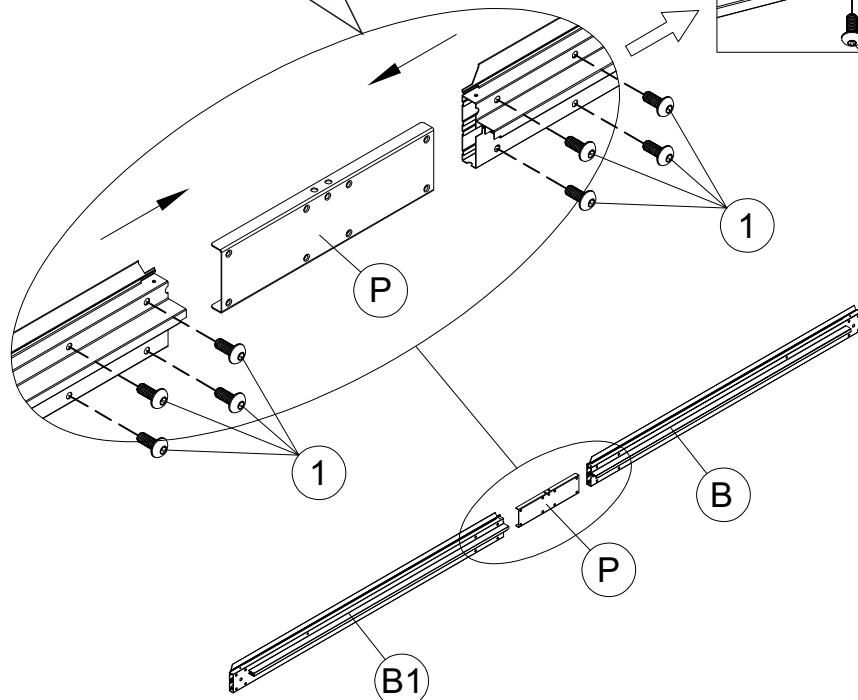
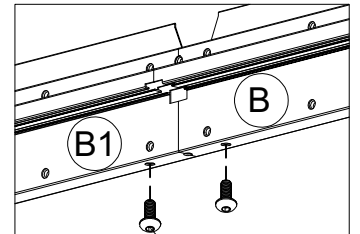

4

<3>

M6x10

2 32x

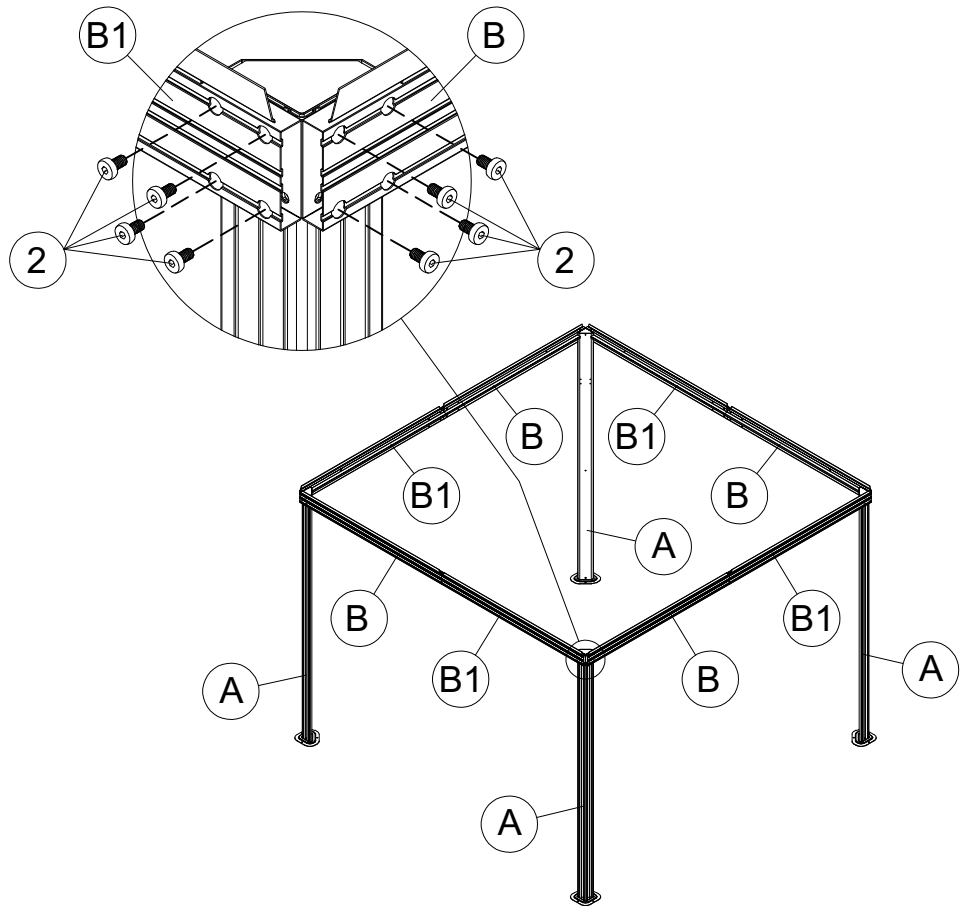

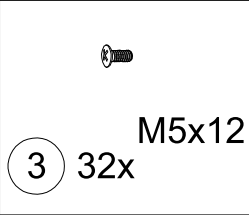
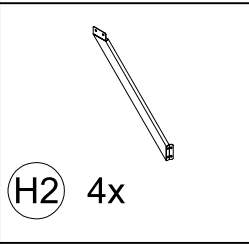
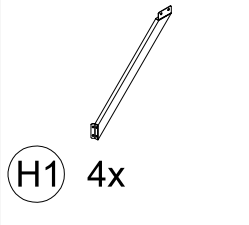

<4>

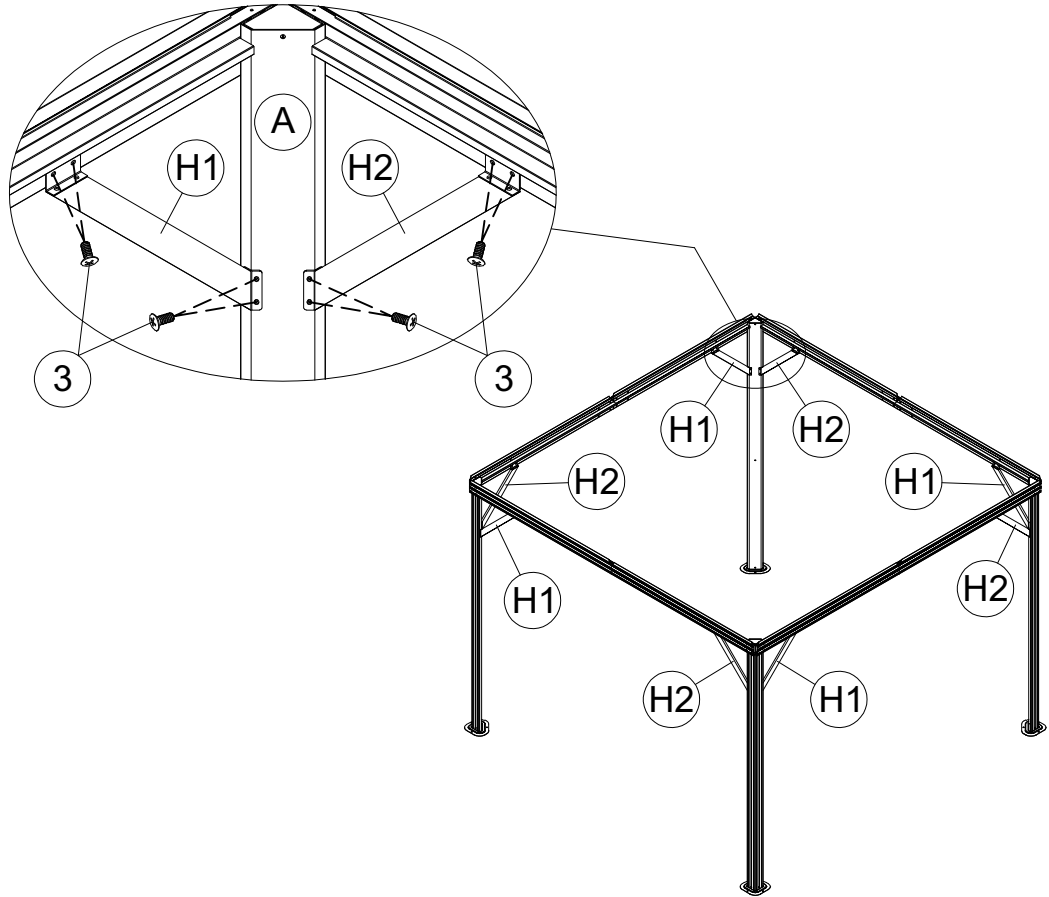

EN: Firstly, install the screws on the beam, but do not tighten them. After the uprights are tightened, then tighten the screws all. If the hole position is not aligned, move the uprights to adjust the position.

DE: Installieren Sie zunächst die Schrauben am Träger, ziehen Sie sie jedoch nicht fest. Nachdem die Pfosten festgezogen sind, ziehen Sie alle Schrauben fest. Wenn die Lochposition nicht ausgerichtet ist, bewegen Sie die Pfosten, um die Position anzupassen.

ES: Primero, instale los tornillos en la viga, pero no los apriete. Después de apretar los postes verticales, apriete todos los tornillos. Si la posición del agujero no está alineada, mueva los postes para ajustar.

FR: Tout d'abord, installez les vis sur le faisceau, mais ne pas les serrer. Une fois les montants serrés, serrez les vis. Si la position du trou n'est pas alignée, déplacez les montants pour ajuster la position.

IT: Innanzitutto, installare le viti sulla trave, ma non stringerle tutte. Dopo che i montanti sono stati fissati, stringere tutte le viti. Se la posizione del foro non è allineata, muover ei montanti al fine di regolarne la posizione.



<5>

H 4x



1 8x M6x15

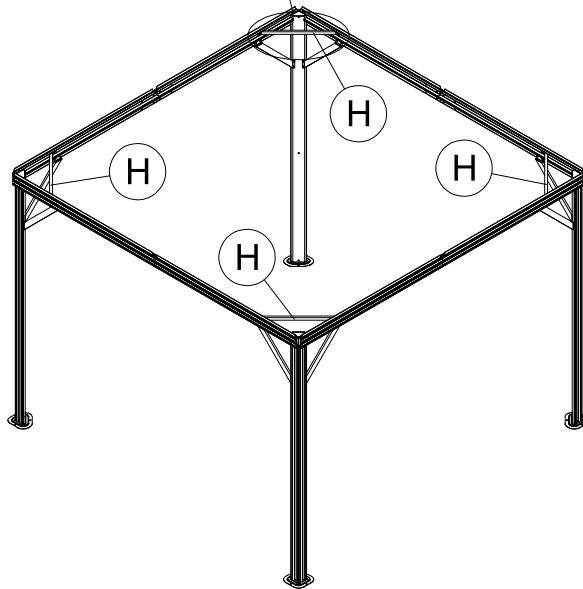
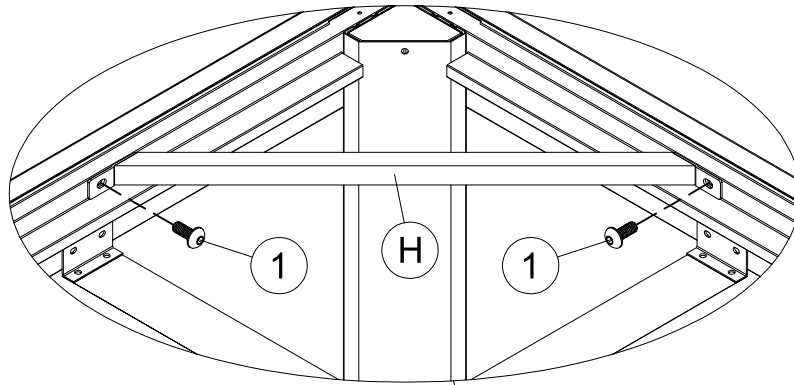

7



(K) 4x



(K1) 4x



(U) 96x



(V) 4x



(3) 4x M5x12



(4) 24x ST4.8x12

<6>

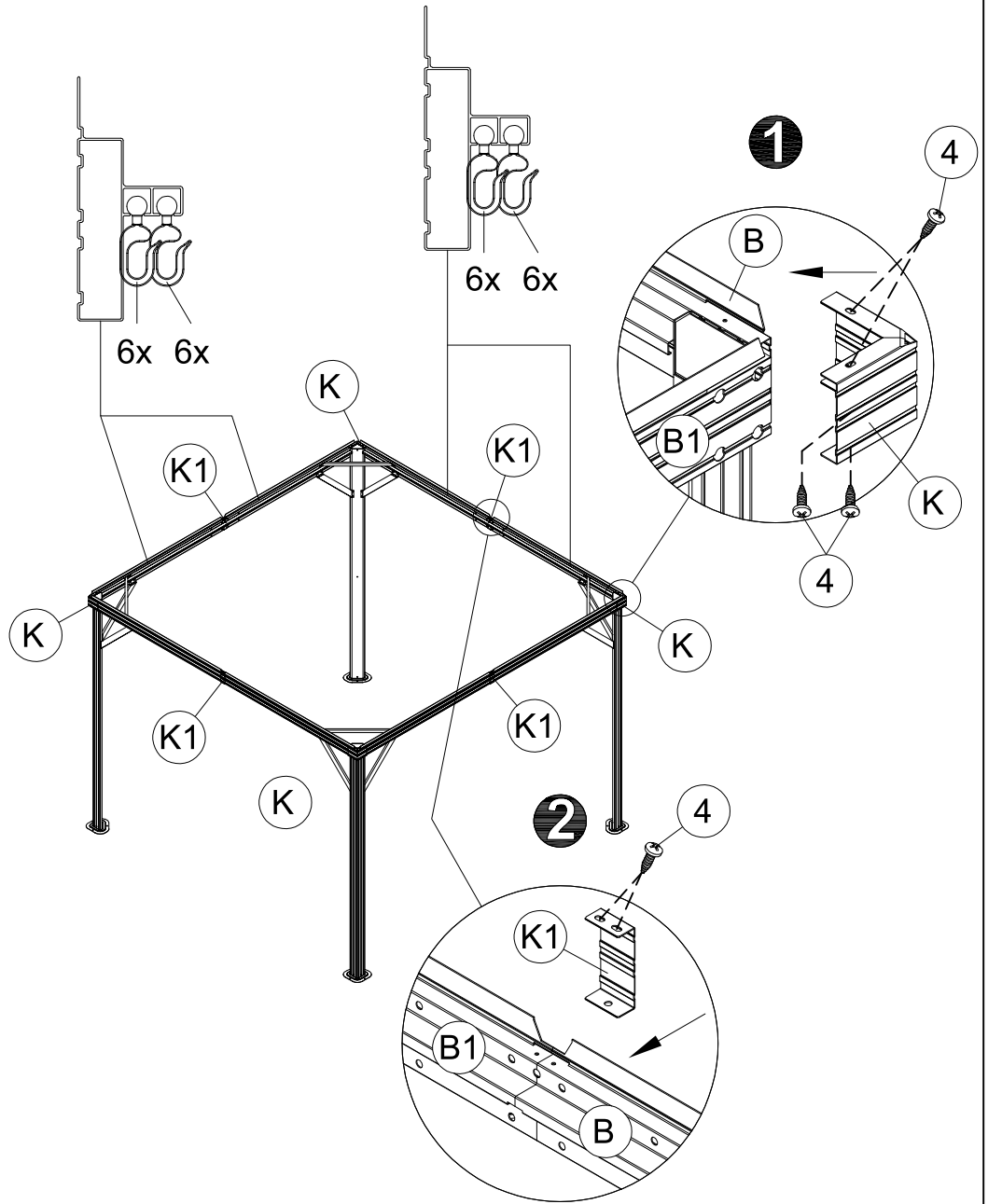

3

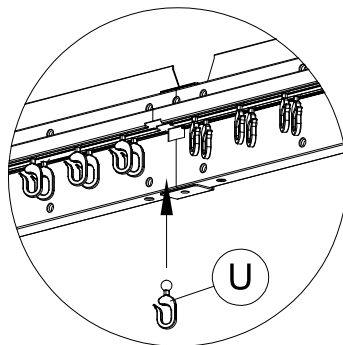

4

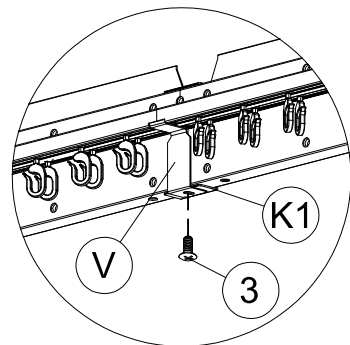

8

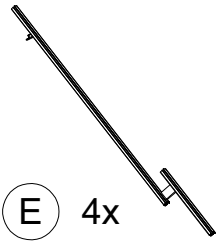

E 4x

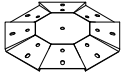

L 1x



1 M6x15
12x

<7>

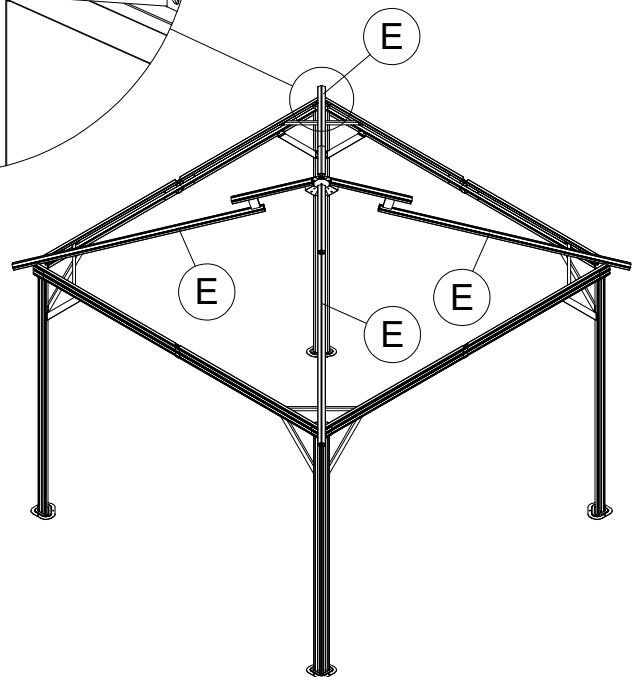
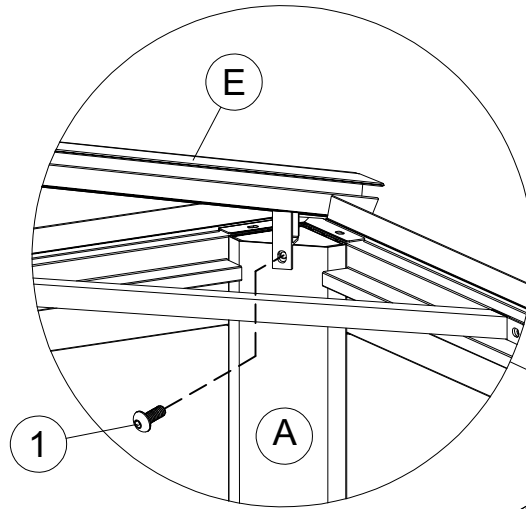
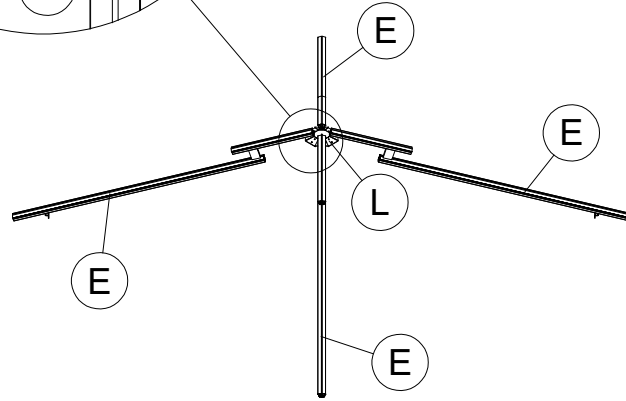
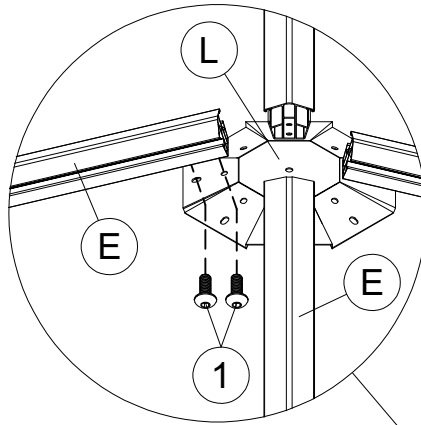

9



<8>

E1 6x



1 M6x15
12x

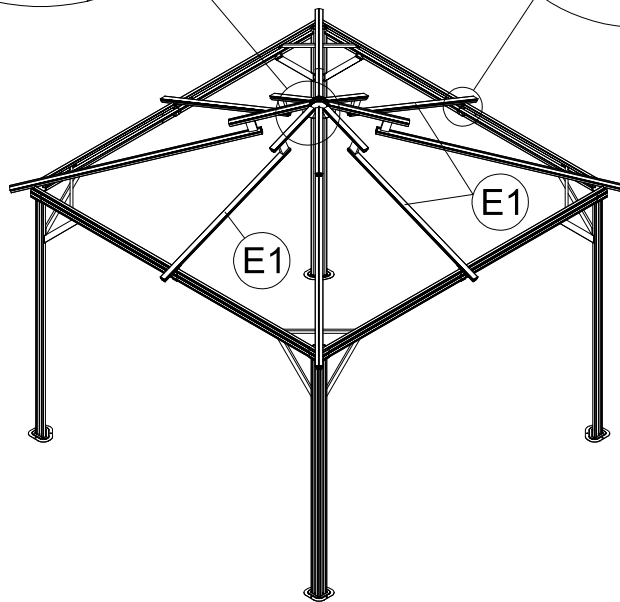
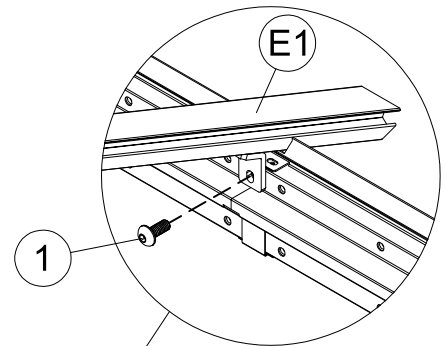
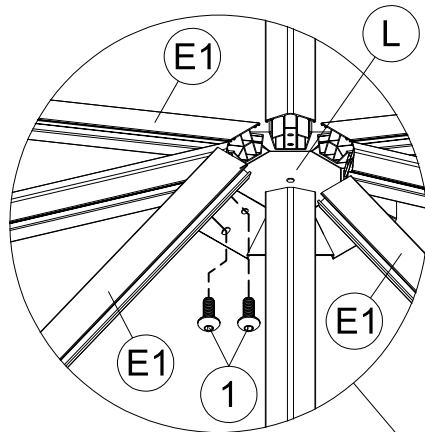

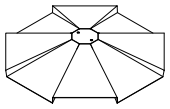

<9>

M 1x



5 1x

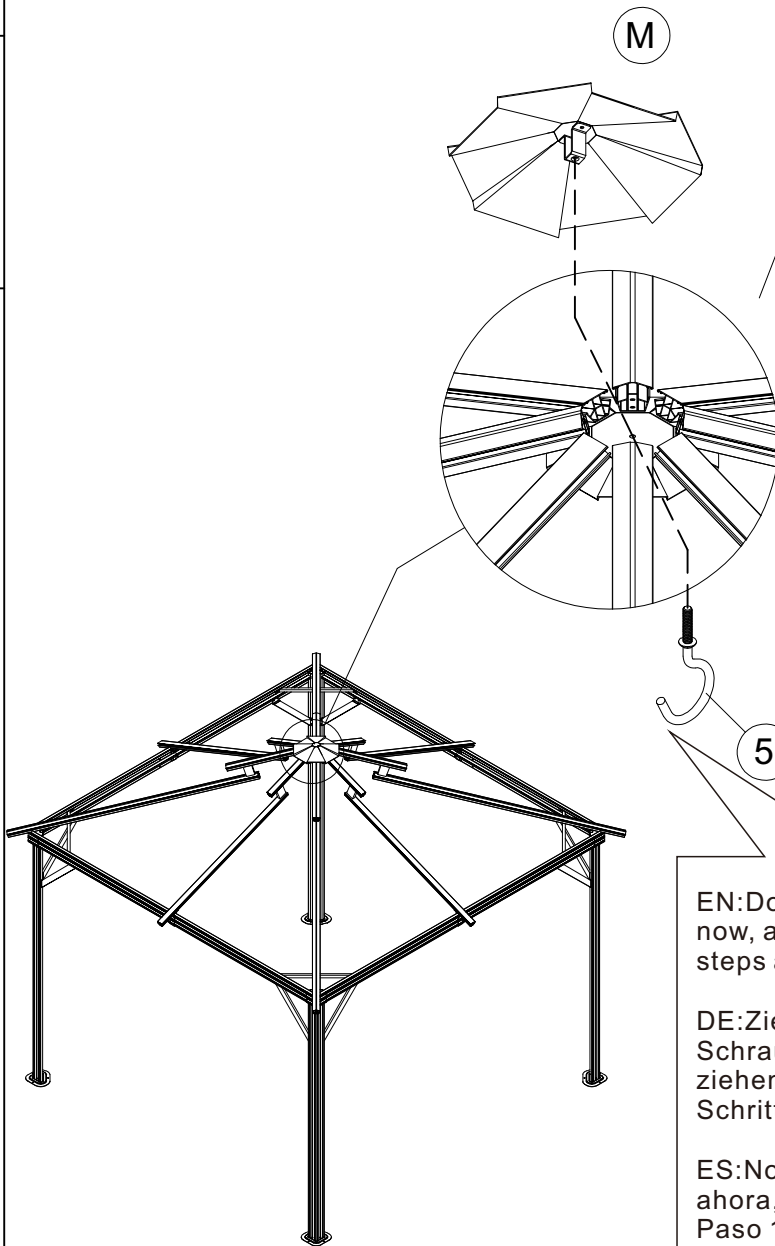

EN:Do not tighten this screws now, and tighten them after 15 steps are completed.

DE:Ziehen Sie diese Schrauben jetzt nicht fest und ziehen Sie sie erst nach 15 Schritten fest.

ES:No apriete esto tornillos ahora, después de completar el Paso 15, ya puede apretarlos.

FR:Ne serrez pas ces vis maintenant, et serrez-les après 15 étapes sont terminées.

IT:Non stringere queste viti ora, ma stringerle dopo il completamento dei 15 passaggi.



<10>

G3 4x



N 4x



1 8x M6x15

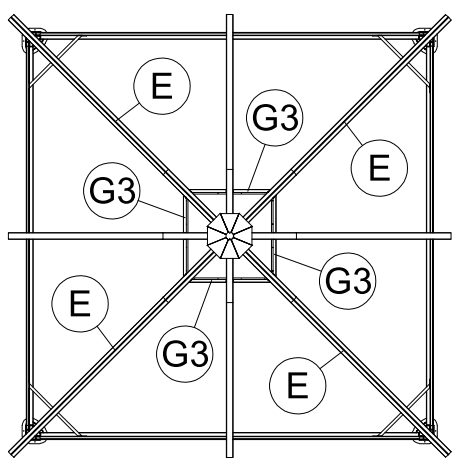
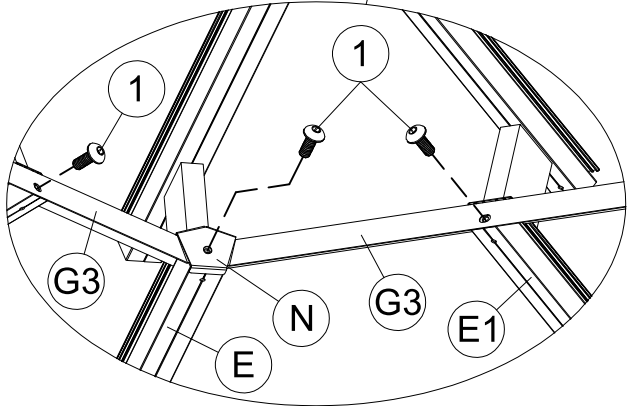
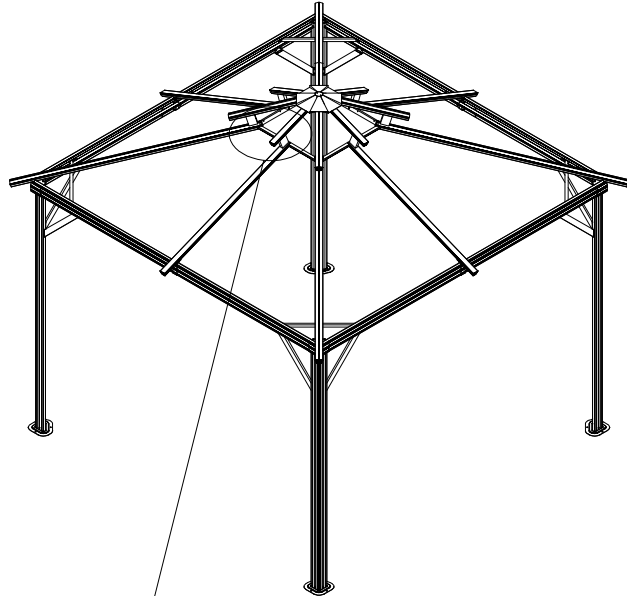



<11>

S1 4x



S2 4x

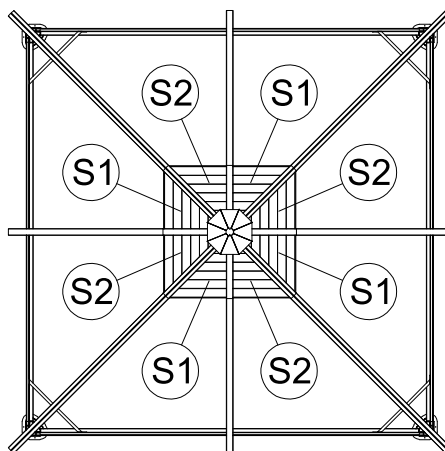
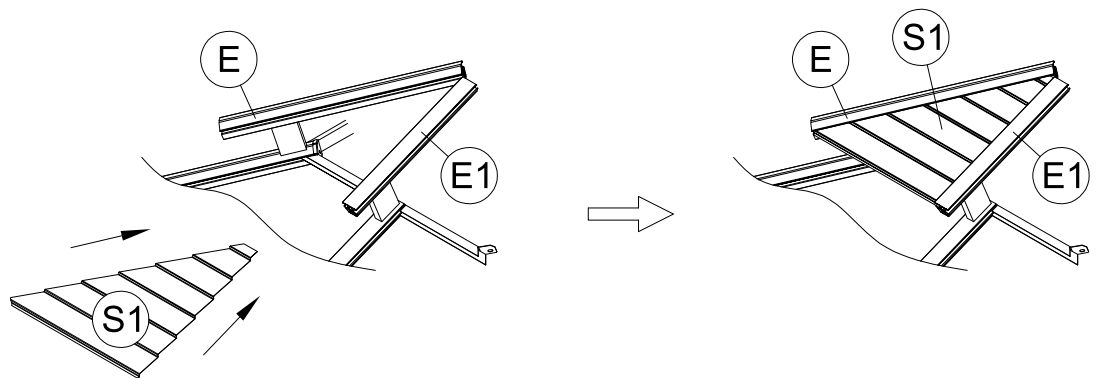
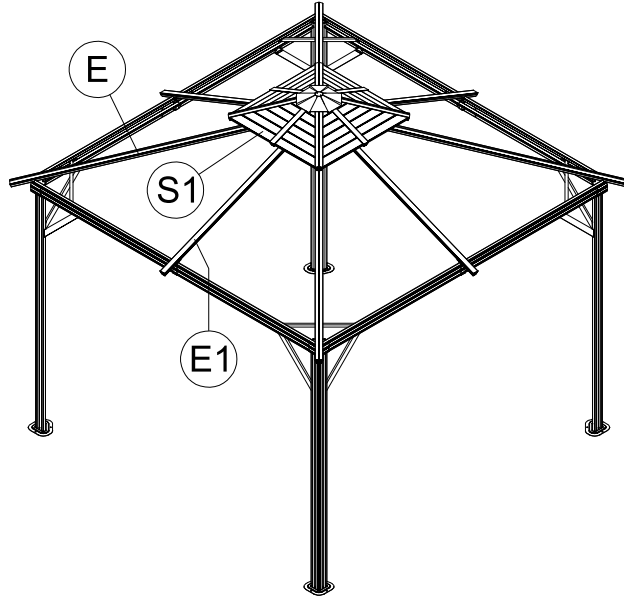

<12>



D1 4x



D2 4x



N 4x



N1 4x



1 8x M6x15

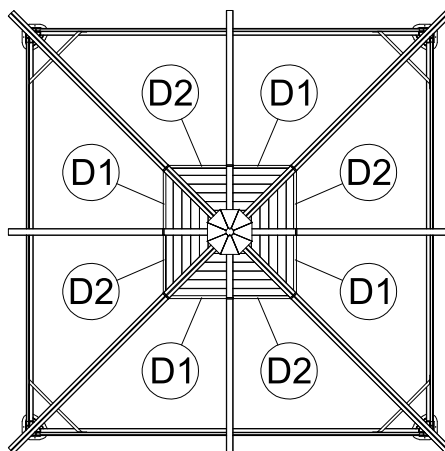
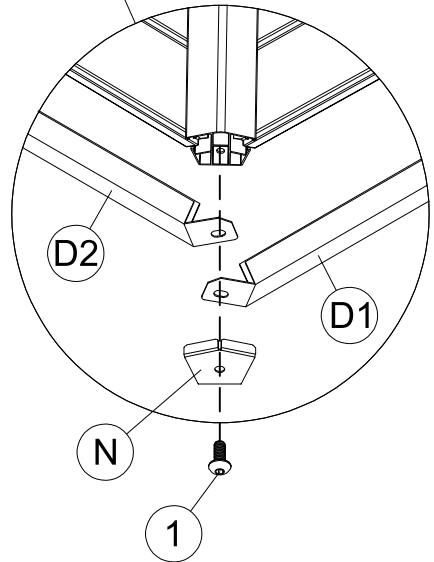
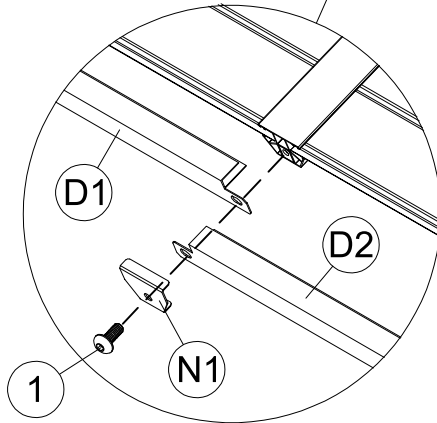
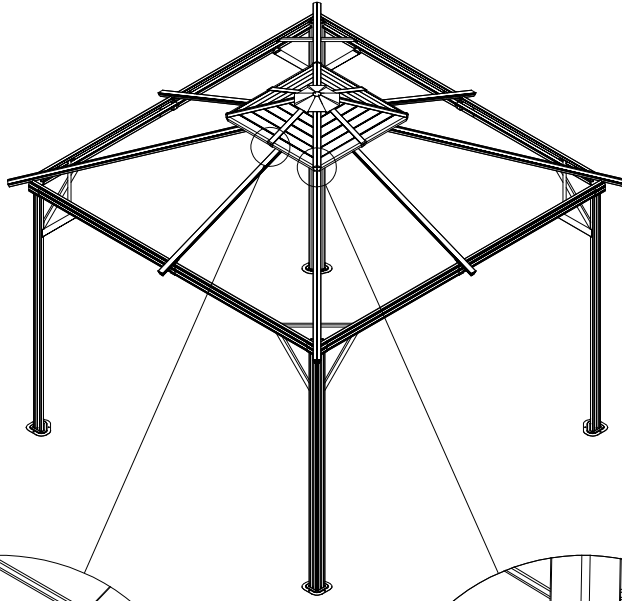

<13>

F1 4x

F2 4x

1 8x M6x15

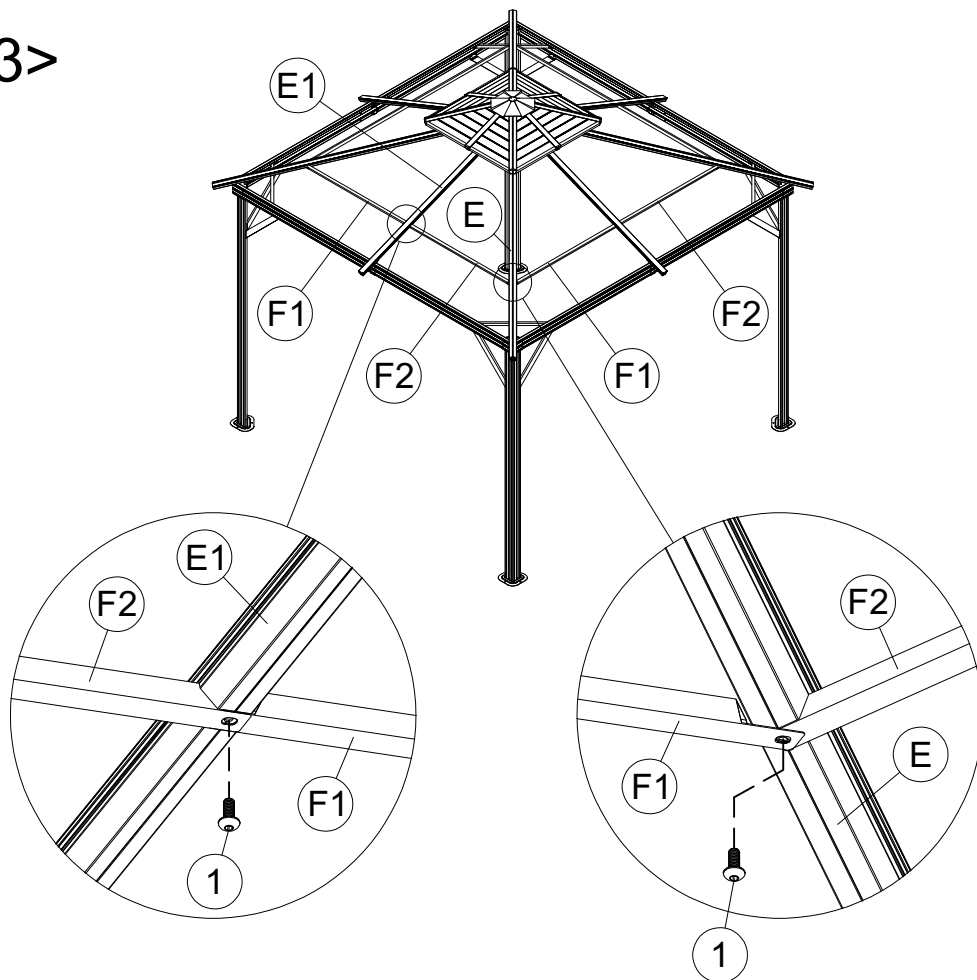

EN: Install in the same direction, do not tighten screws fully until all parts are connected.

DE: Installieren Sie in die gleiche Richtung und ziehen Sie die Schrauben nicht fest an, bis alle Teile angeschlossen sind.

ES: Instale en la misma dirección, no apriete los tornillos de manera completa hasta que todas las partes estén conectadas.

FR: Installez dans le même sens, ne serrez pas les vis à fond tant que toutes les pièces ne sont pas connectées.

IT: Installare nella stessa direzione, non stringere le viti completamente finché tutte le parti non sono state connesse.

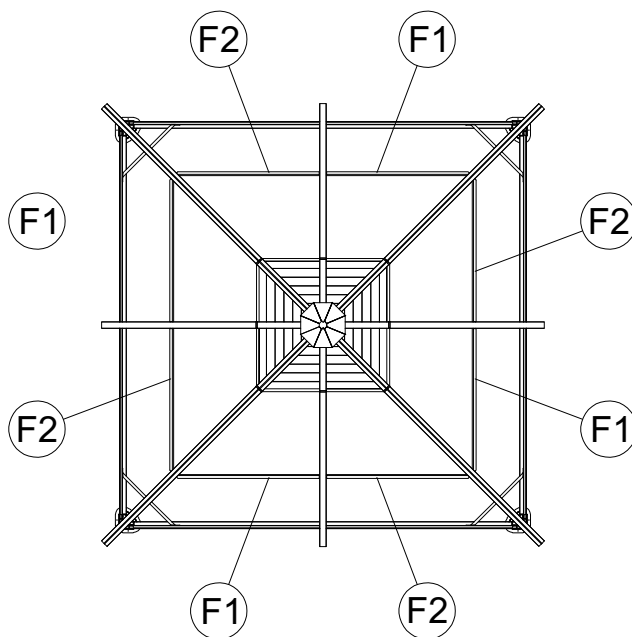

15

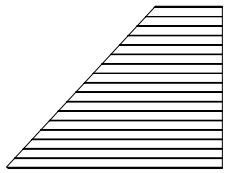

Q1 4x

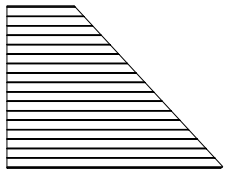

Q2 4x

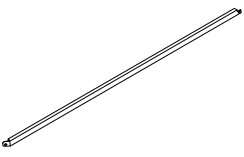

G1 4x

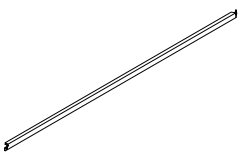

G2 4x



N 4x



N1 4x



1 8x M6x15

16

<14>

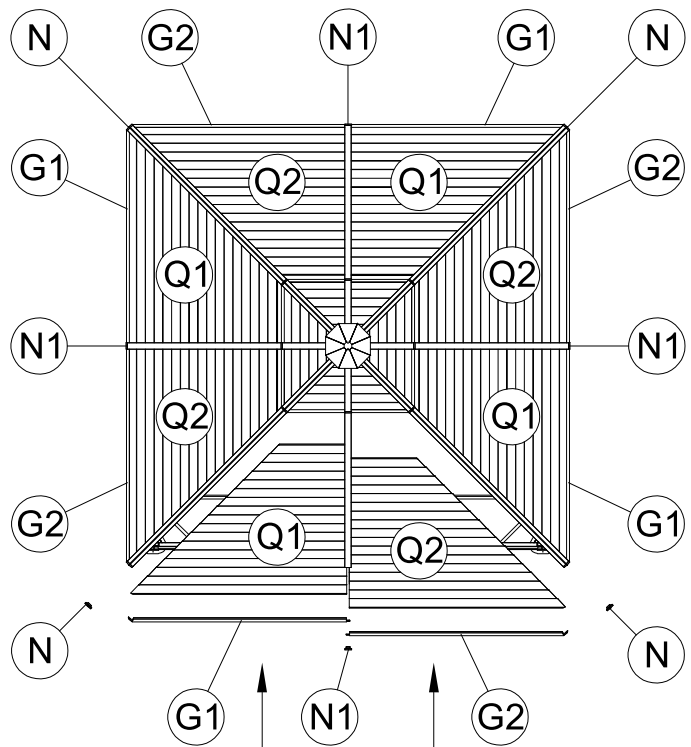
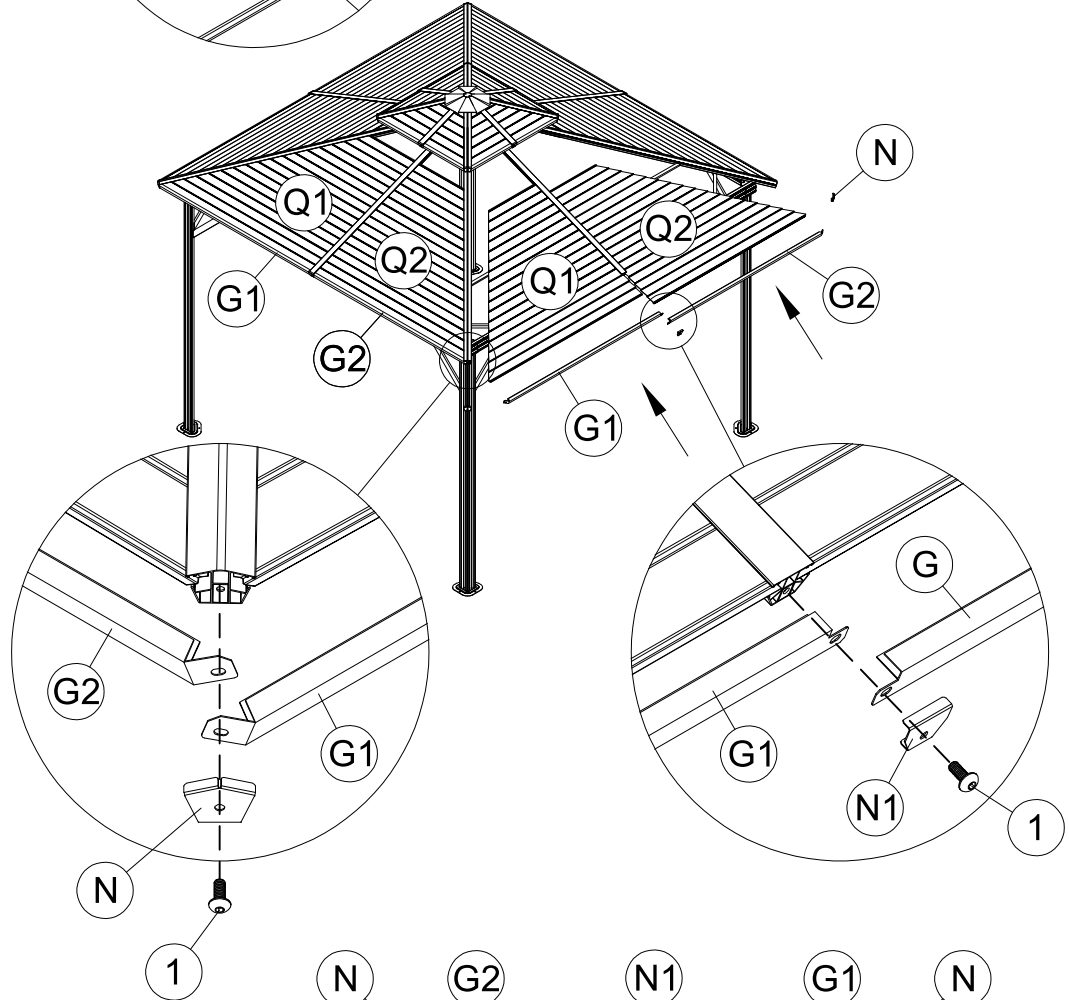
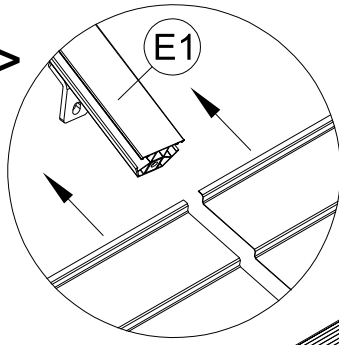



<15>

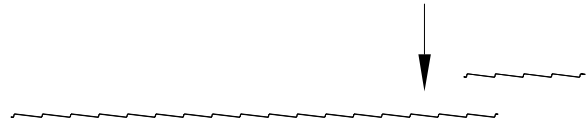

(R1) 4x



(R2) 4x



(Y) 16x

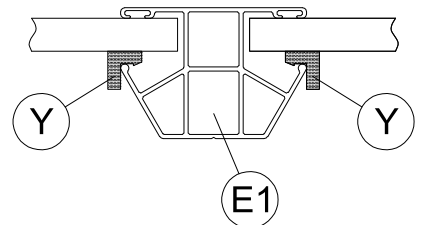
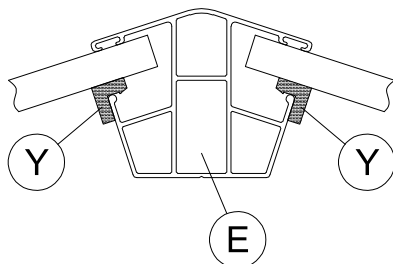
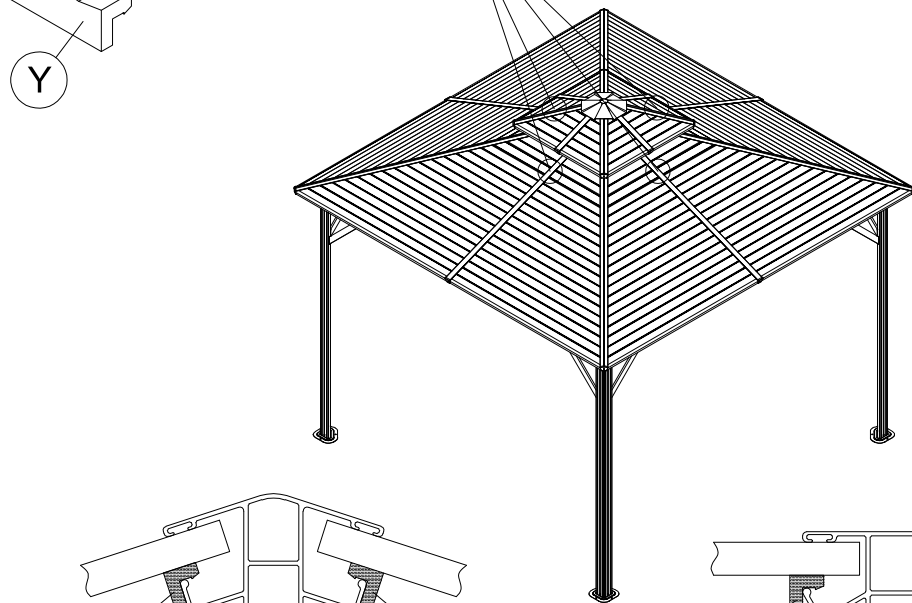
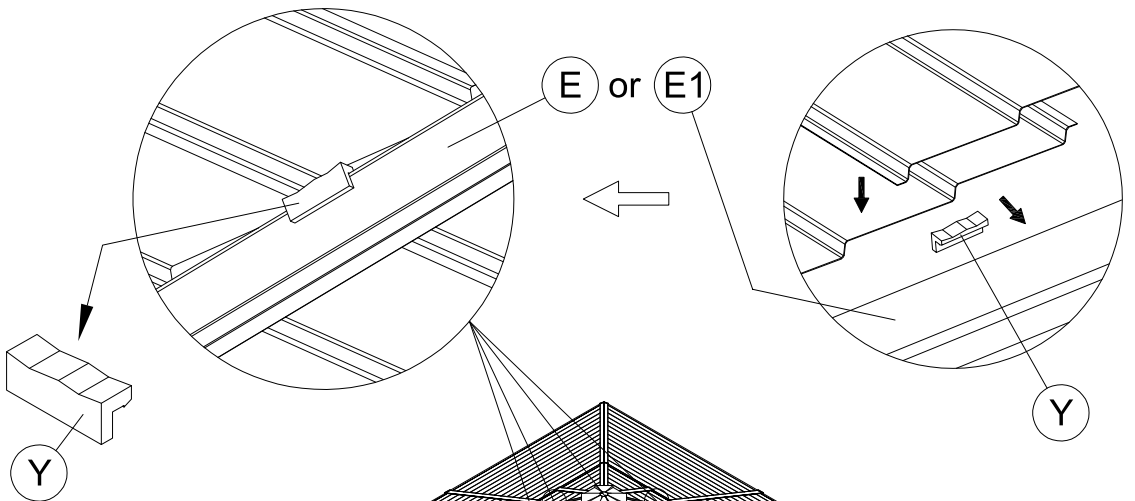
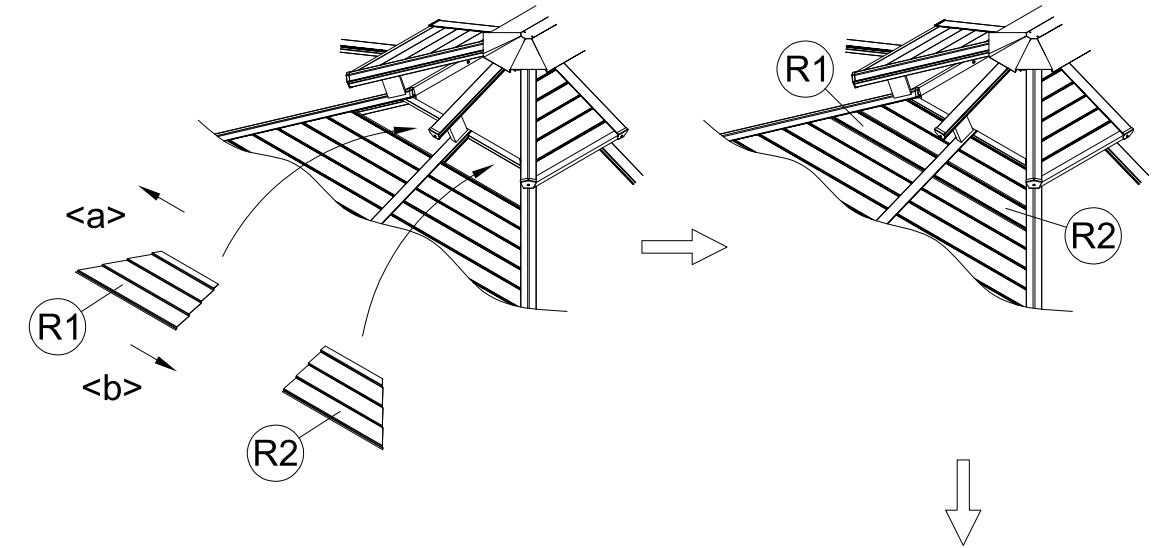

17

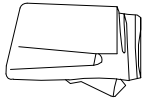

<16>

T 4x

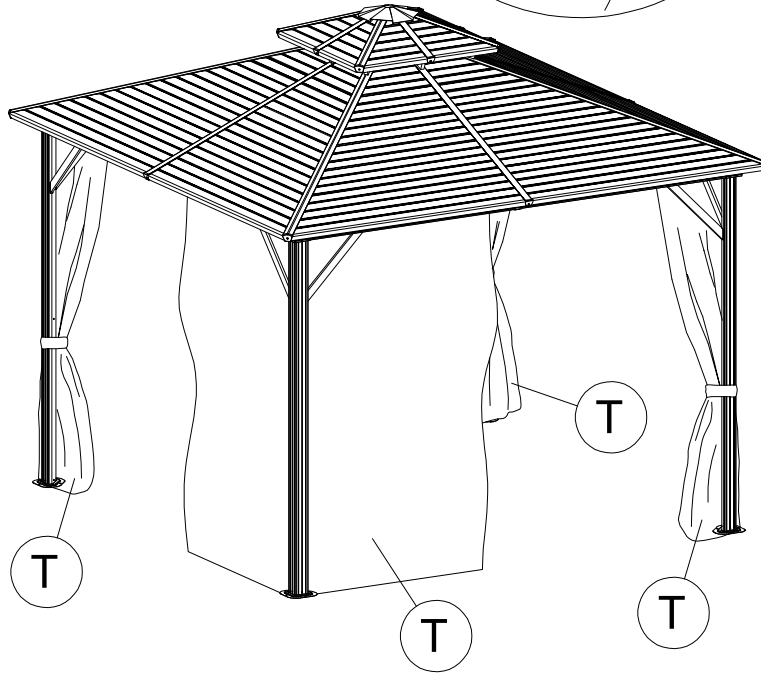
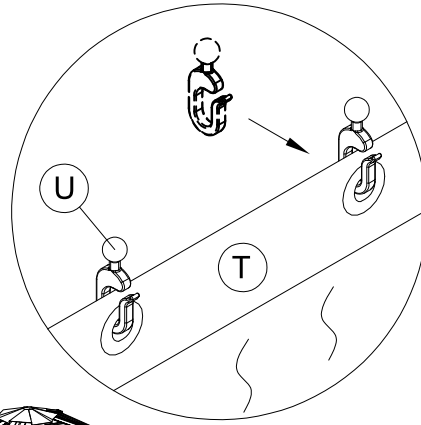
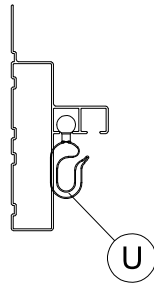

EN:1.S and T are divided into left and right directions, identification method: take apart the four zippers, and install S/T in a single piece.

The iron hook on S passes through the hole on T and hooks on the small hole of the upright.

2. There is no separate Bandage on T, the Bandage has been sewn on S.

DE:1.S und T sind in linke und rechte Richtung unterteilt. Identifikationsmethode: Nehmen Sie die vier Reißverschlüsse auseinander und installieren Sie S / T in einem Stück.

2. Der Eisenhaken an S geht durch das Loch an T und hakt an dem kleinen Loch des Pfostens.

2. Es gibt keinen separaten Verband auf T, der Verband wurde auf S genäht.

ES:1.S y T se dividen en direcciones izquierda y derecha, el método de identificación es siguiente: Desmontar las cuatro cremalleras e instalar S / T como una sola pieza.

2. El gancho de hierro en S pasa a través del orificio en T y se engancha en el pequeño orificio del poste.

No hay un vendaje separado en T, el vendaje se ha cosido en S.

FR:1.S et T sont divisés en directions gauche et droite, méthode d'identification : démontez les quatre fermetures éclair, et installez S / T en une seule pièce. Le crochet en fer sur S passe à travers le trou sur T et crochets sur le petit trou du montant.

2. Il n'y a pas de bandage séparé sur T, le bandage a été cousu sur S.

IT:1.S e T sono divisa tra direzione sinistra e destra, identificabili in questo modo: slacciare le quattro cerniere e installare S/T in un solo pezzo.

Il gancio in metallo su S passa attraverso il foro di T e si aggancia al piccolo foro del montante.

2. Non ci sono cinghie separate su T, la cinghia e' stata cucita su S.

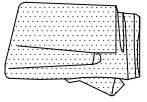

+



T1 4x + 1x

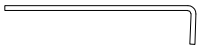

W 12x



8 12x

<17>

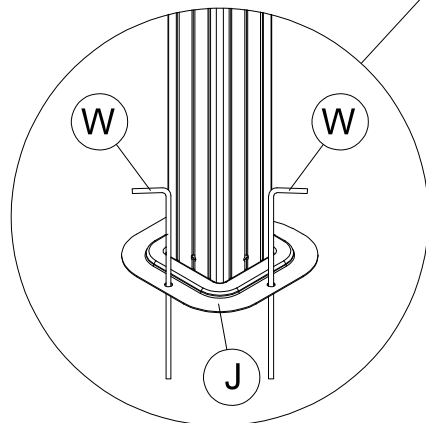
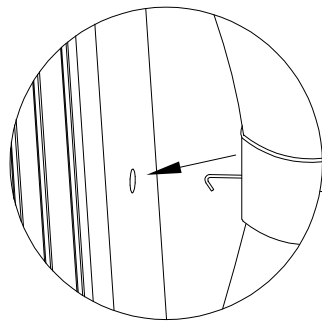
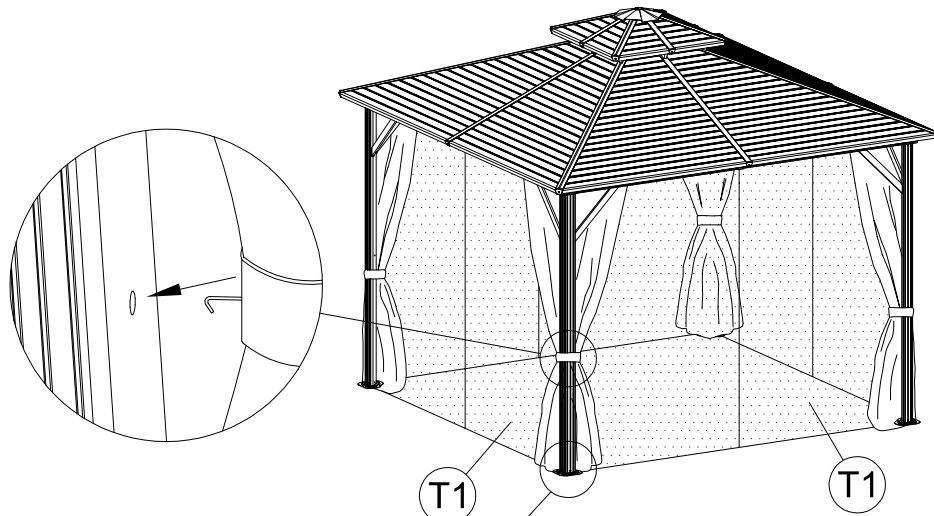
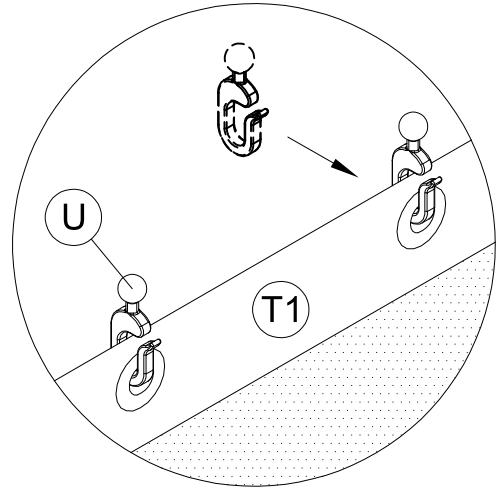
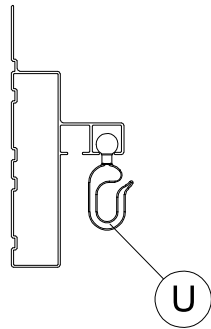
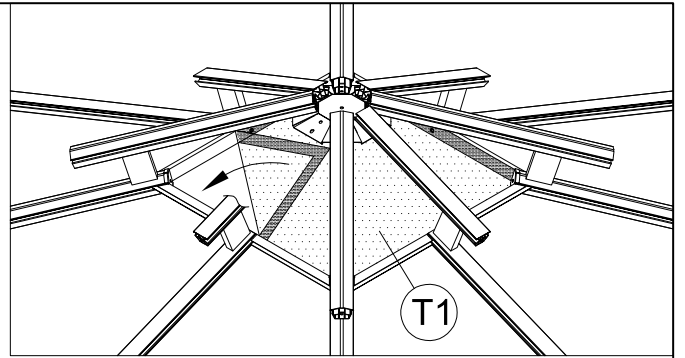

or

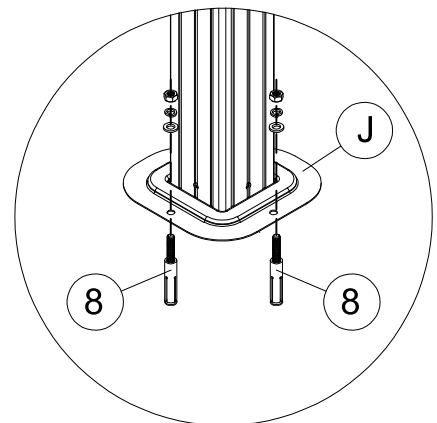

US

Imported by Aosom LLC
27150 SW Kinsman Rd Wilsonville, OR 97070 USA
Manufactured in Ningbo City, Zhejiang Province, China
MADE IN CHINA

CA

Imported by Aosom Canada Inc.
1251 Tapscott Road, Unit 101, Scarborough, Ontario Canada M1X 1S9
Manufactured in Ningbo City, Zhejiang Province, China
MADE IN CHINA

Importé par Aosom Canada Inc.
1251 Rue Tapscott, Unité 101, Scarborough, Ontario Canada M1X 1S9
Fabriqué à Ville de Ningbo, Province du Zhejiang, Chine
FABRIQUÉ EN CHINE

UK

IMPORTER ADDRESS:
MH STAR UK LTD
Unit 27, Perivale Park,
Horsenden lane South
Perivale, UB6 7RH
MADE IN CHINA

FR

ADRESSE D'IMPORTATION:
MH FRANCE
2 Rue Maurice Hartmann
92130 Issy Les Moulineaux
France
FABRIQUÉ EN CHINE

ES

IMPORTADOR:
SPANISH AOSOM, S.L.
C/ROC GROS,Nº15.08550, ELS HOSTALET DE BALENYÀ, SPAIN.
B66295775
WWW.AOSOM.ES
ATENCIONCLIENTE@AOSOM.ES
TEL: 931294512
HECHO EN CHINA

DE

ADRESSE DES IMPORTEURE:
MH Handel GmbH
Wendenstraße 309
D-20537 Hamburg
Germany
IN CHINA HERGESTELLT

IT

IMPORTATO DA:
AOSOM Italy srl
Centro Direzionale Milanofiori
Strada 1 Palazzo F1
20057 Assago (MI)
P.I.: 08567220960
FATTO IN CINA