

EN_IMPORTANT, RETAIN FOR FUTURE REFERENCE: READ CAREFULLY.

FR_IMPORTANT: A LIRE ATTENTIVEMENT ET À CONSERVER POUR CONSULTATION ULTÉRIEURE.

ES_IMPORTANTE, LEA Y GUARDE PARA FUTURAS REFERENCIAS.

DE_, WICHTIG! SORGFÄLTIG LESEN UND FÜR SPÄTER NACHSCHLAGEN AUFBEWAHREN."

IT_IMPORTANTE! CONSERVARE IL PRESENTE MANUALE PER FUTURO RIFERIMENTO E LEGGERLO ATTENTAMENTE.

EN

Dear customer,

Thank you for purchasing this product. So that your appliance serves you well, please read all the instructions in this user's manual. If you have any questions, please contact our customer care center.

FR

Cher client,

Nous vous remercions d'avoir acheté ce produit. Afin que vous puissiez profiter pleinement de votre appareil, veuillez lire toutes les instructions de ce manuel d'utilisation. Si vous avez la moindre question, veuillez contacter notre centre d'assistance à la clientèle.

DE

Sehr geehrter Kunde,

Vielen Dank, dass Sie dieses Produkt erworben haben. Damit Ihr Gerät Ihnen gute Dienste leistet, lesen Sie bitte alle Hinweise in diesem Benutzerhandbuch. Wenn Sie Fragen haben, wenden Sie sich bitte an unser Kundendienstzentrum.

ES

Queridos clientes,

Gracias por comprar este producto. Para que su electrodoméstico le sirva mejor, lea todas las instrucciones de este manual del usuario. Si tiene alguna pregunta, comuníquese con nuestro Centro de Atención al Cliente.

PT

Caros clientes,

Obrigado por adquirir este produto. Para que o seu aparelho o sirva melhor, leia todas as instruções deste manual do utilizador. Se tiver alguma dúvida, por favor contacte o nosso Centro de Atendimento ao Cliente.

IT

Caro Cliente,

Grazie per aver acquistato questo prodotto. Per servirti meglio con questo apparecchio ti prego di leggere tutte le istruzioni in presente manuale utente. In caso di dubbio, si prega di contattare il nostro centro assistenza clienti.

EN_Our contact details are below:



FR_Nos coordonnées sont les suivantes:

DE_Unsere Kontaktdaten stehen unten:

ES_Nuestros datos de contacto son los siguientes:

PT_Os nossos dados de contacto são os seguintes:

IT_I nostri dettagli di contatto sono di seguito:

Country	 Phone	 Email
UK	0044-800-240-4004	enquiries@mhstar.co.uk
DE	0049-0(40)-88307530	service@aosom.de
FR	0033-1-84166106	aosom@mhfrance.fr
ES&PT	0034-931294512	atencioncliente@aosom.es
IT	0039-0249471447	clienti@aosom.it

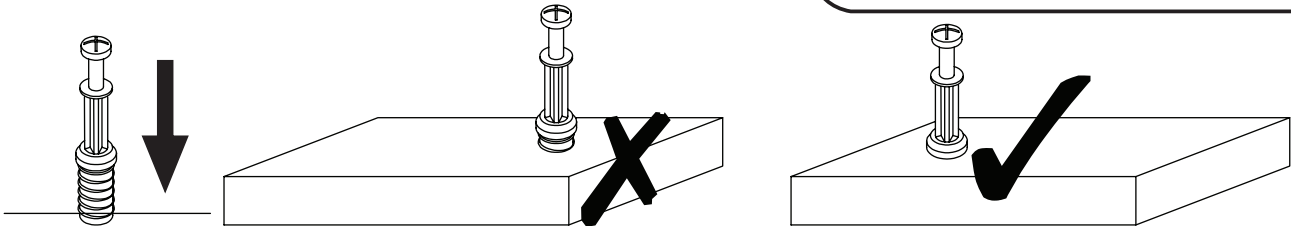

EN_QUICKFIT: Tighten quickfit until shoulder is flush with panel. Do not overtighten or undertighten.

FR_RACCORD RAPIDE: Faites serrer le raccord rapide jusqu'à ce que l'épaulement soit parfaitement encastré dans le panneau. Il ne faut ni trop serrer ni insuffisamment serrer.

ES_QUICKFIT: Apriete quickfit hasta que el hombro se descargue con el panel. NO lo sobreapriete ni lo apriete poco.

DE_QUICKFIT: Ziehen Sie den Quickfit fest, bis die Schulter mit der Platte bündig ist. Bitte nicht zu fest oder zu schwach anziehen.

IT_MONTAGGIO RAPIDO: Stringere il montaggio rapido fino a quando la spalla è a filo con il pannello, non stringere troppo o troppo poco.

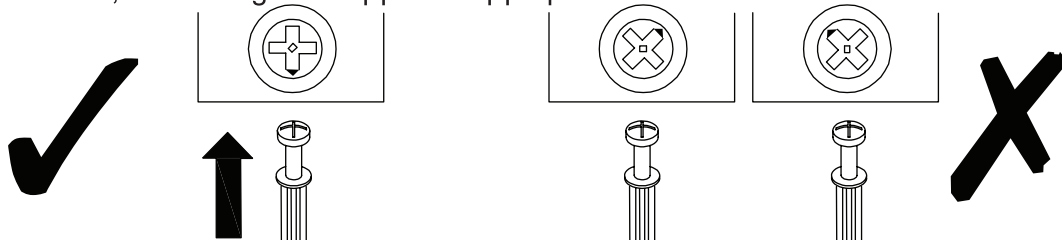

EN_CAM LOCK: When fitting cam lock, ensure starting position is correct before you insert connecting quickfit.

FR_SERRURE BATTEUSE: Avant d'insérer la serrure batteuse, veillez à la bonne orientation avant d'insérer le raccord rapide.

ES_CIERRE DE LA CÁMARA: Cuando instale el cierre de la cámara, asegúrese de que la posición de inicio es correcta antes de que inserte el quickfit conector.

DE_CAM-LOCK: Achten Sie bei der Montage des Cam-Locks auf die richtige Ausgangsposition, bevor Sie den Quickfit einsetzen.

IT_BLOCCAGGIO A CAMMA: Quando si monta il bloccaggio a camma, assicurarsi che la posizione iniziale sia corretta prima di inserire il montaggio rapido di collegamento.

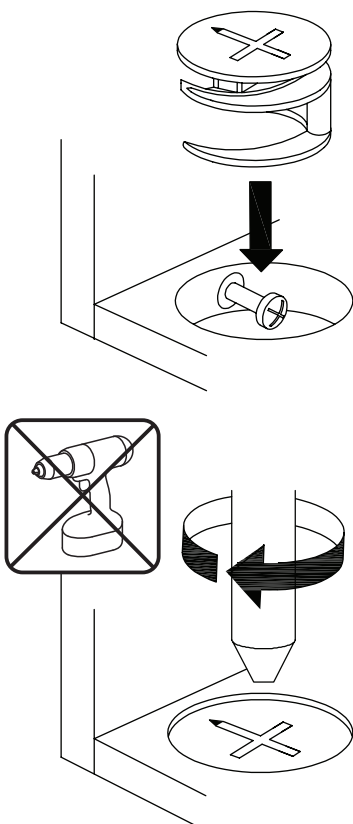

EN_Quickfit head should be in the centre of the cam lock when the two panels are joined.

Cam lock should be inserted before quickfit.

FR_Lorsque les deux panneaux sont assemblés, la tête du raccord rapide doit reposer au centre de la serrure batteuse. Il faut insérer la serrure batteuse avant le raccord rapide.

ES_El cabezal del quickfit debe estar en el centro del cierre de la cámara cuando se unan los dos paneles.

Se debe insertar el cierre de la cámara antes que el quickfit.

DE_Der Quickfit-Kopf sollte sich in der Mitte des Cam-Locks befinden, wenn die beiden Platten zusammengefügt sind.

Der Cam-Lock sollte vor dem Quickfit eingesetzt werden.

IT_La testa del montaggio rapido deve trovarsi al centro del bloccaggio a camma quando i due pannelli sono uniti.

Il Bloccaggio a Camma deve essere inserito prima del montaggio rapido.

EN_Turn cam lock clockwise to tighten.

FR_Faites tourner la serrure batteuse dans le sens des aiguilles d'une montre pour la resserrer.

ES_Gire el cierre de la cámara en sentido horario para apretarlo.

DE_Drehen Sie den Cam-Lock im Uhrzeigersinn, um ihn festzuziehen.

IT_Ruotare il bloccaggio a camma in senso orario per stringere.

EN It may be necessary to adjust the hinges so that the doors align. Use the instructions below as a guide.

FR Il est parfois nécessaire d'ajuster les charnières pour un meilleur alignement des portes. Servez-vous des instructions ci-dessous comme guide.

ES Puede que sea necesario ajustar los quicios de forma que se alineen las puertas. Use las instrucciones que aparecen debajo como guía.

DE Möglicherweise müssen Sie die Scharniere so einstellen, dass die Türen ausgerichtet sind. Verwenden Sie die nachstehenden Anweisungen als Leitfaden.

IT Potrebbe essere necessario regolare le cerniere in modo che le porte siano allineate. Per fare ciò attenersi alle istruzioni sottostanti.

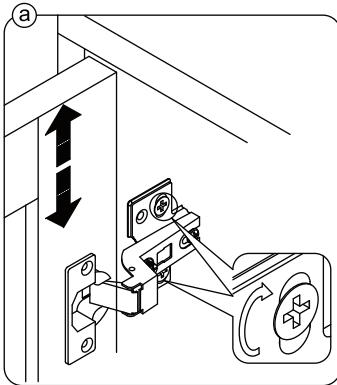

EN To adjust the door vertically loosen the screw as shown and move up and down as needed.

FR Si vous souhaitez régler la porte **verticalement**, desserrez la vis comme indiqué et déplacez la porte de haut en bas selon les besoins.

ES Para ajustar la puerta **verticalmente** afloje el tornillo tal y como se muestra y muévelo hacia arriba o hacia abajo según sea necesario.

DE Um die Tür **vertikal** auszurichten, lösen Sie die Schraube wie abgebildet und bewegen Sie sie nach Bedarf nach oben oder nach unten.

IT Per allineare la porta **verticalmente** allentare la vite come mostrato e spostarla in alto o in basso secondo necessità.

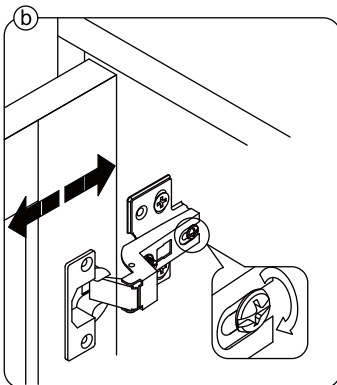

EN To adjust the gap from the door to the main frame turn the screw clockwise or anti-clockwise as needed.

FR Si vous souhaitez ajuster l'**écart** entre la porte et le cadre principal, tournez la vis dans le sens des aiguilles d'une montre ou dans le sens inverse, si nécessaire.

ES Para ajustar el **espacio** desde la puerta al marco principal, gire el tornillo en sentido horario o antihorario, según se necesite.

DE Um den **Abstand** von der Tür zum Hauptrahmen auszurichten, drehen Sie die Schraube je nach Bedarf im oder gegen den Uhrzeigersinn.

IT Per regolare lo **spazio** tra la porta e il telaio principale, avvitare o svitare la vite secondo necessità.

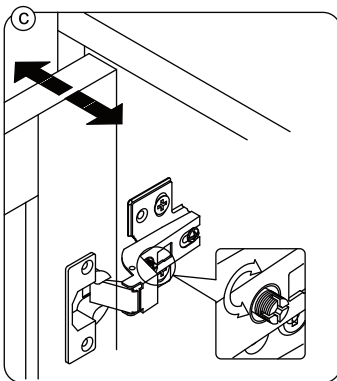

EN To adjust the door laterally adjust the screw as shown by turning clockwise or anti-clockwise.

FR Si vous souhaitez ajuster la porte **latéralement**, ajustez la vis comme indiqué en tournant dans le sens des aiguilles d'une montre ou dans le sens inverse des aiguilles d'une montre.

ES Para ajustar la puerta **lateralmente** ajuste el tornillo tal y como se muestra girándolo en sentido horario y antihorario.

DE Um die Tür **seitlich** auszurichten, stellen Sie bitte die Schraube wie abgebildet durch Drehen im oder gegen den Uhrzeigersinn ein.

IT Per allineare la porta **lateralmente** regolare la vite come mostrato, avvitarandola o svitarandola.

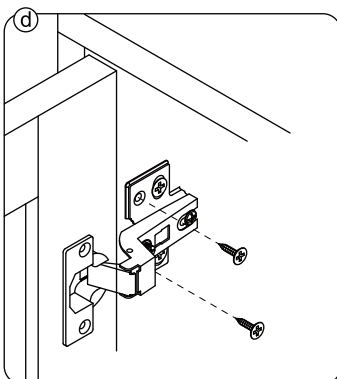

EN Please fix other screws



FR Merci de serrer les autres vis.

ES Fije los demás tornillos

DE Befestigen Sie bitte die anderen Schrauben

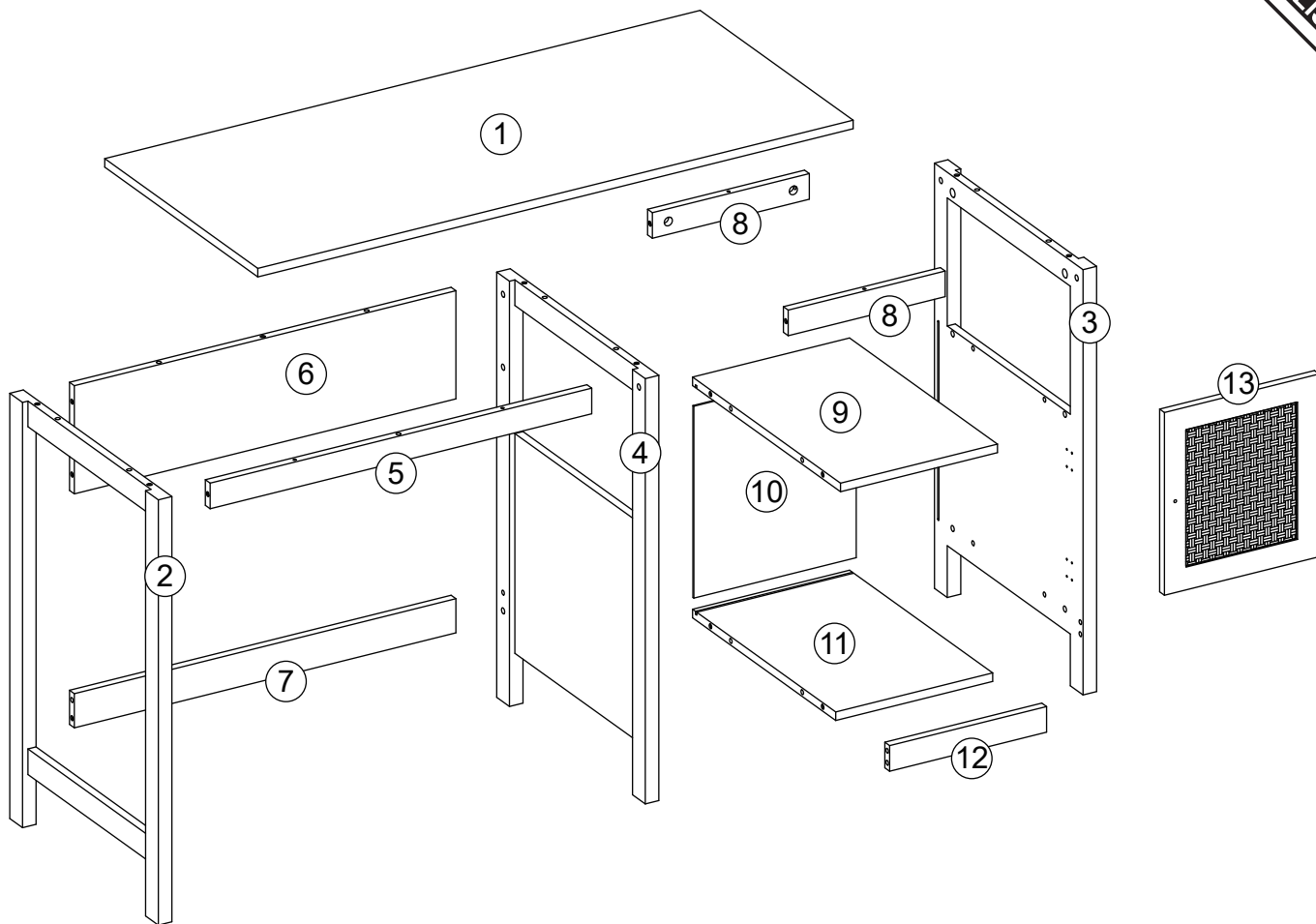
IT Fissare le altre viti

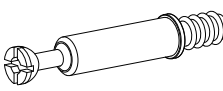
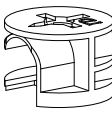
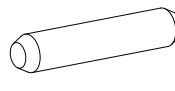
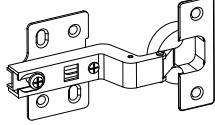

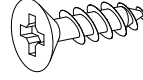
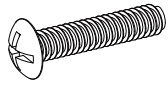
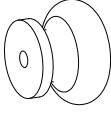
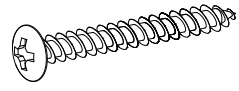
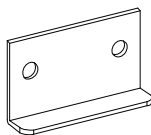
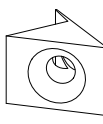
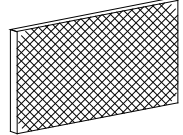
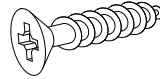
	<p>A x27 +2 (spare)</p>		<p>B x27 +2 (spare)</p>		<p>C x23 M8*30 +2 (spare)</p>
	<p>D x 2</p>		<p>E x 2 M3*12</p>		<p>F x12 M4*12 +1 (spare)</p>
	<p>G x1 M4*18</p>		<p>H x 1</p>		<p>I x 4 M4*50 +1 (spare)</p>
	<p>J x 1</p>		<p>K x 4 +1 (spare)</p>		<p>L x 6</p>
	<p>M x4 M3*14 +1 (spare)</p>				

01

A x 4

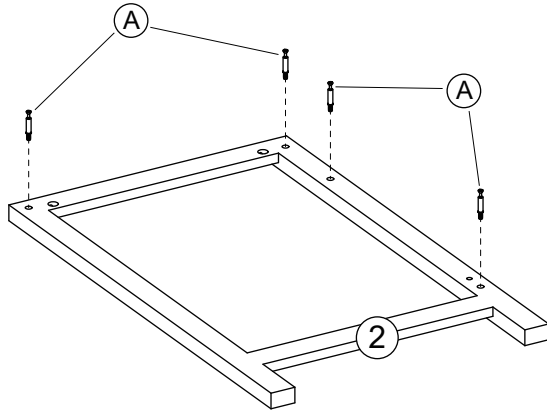
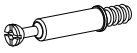

02

A x 10

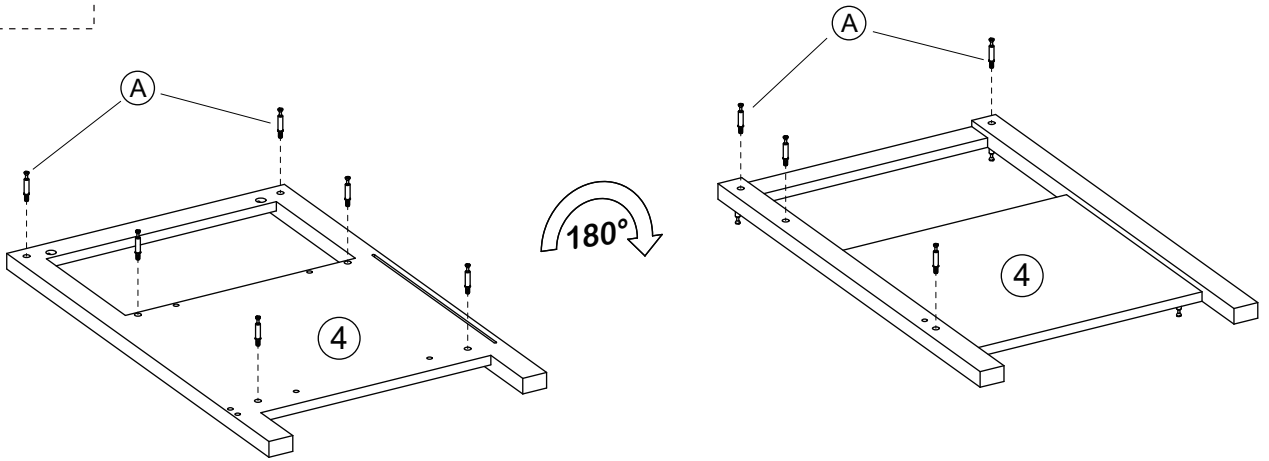

03

B x 4



C x 1

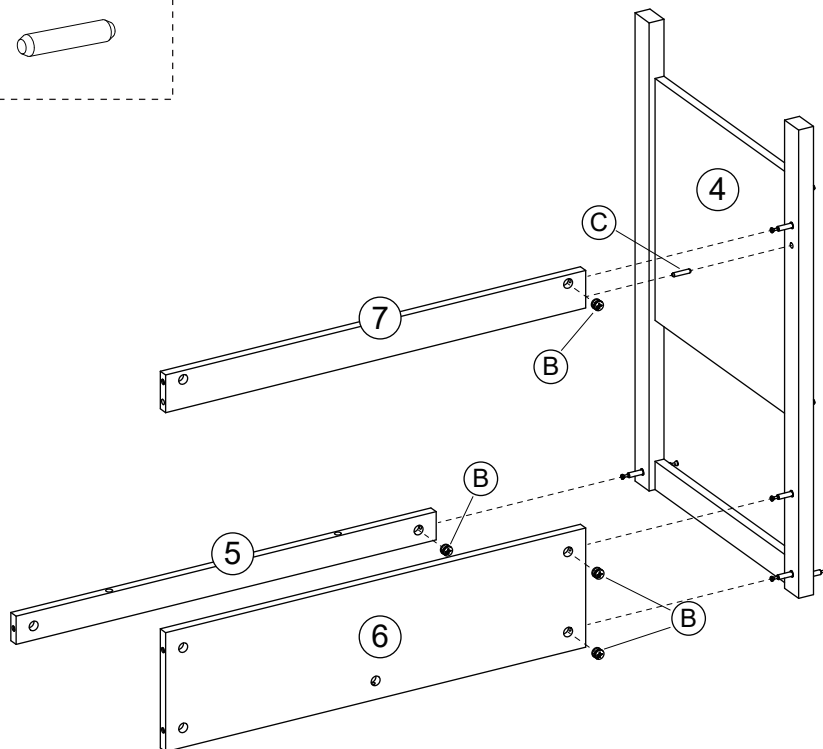

B x 4

C x 1

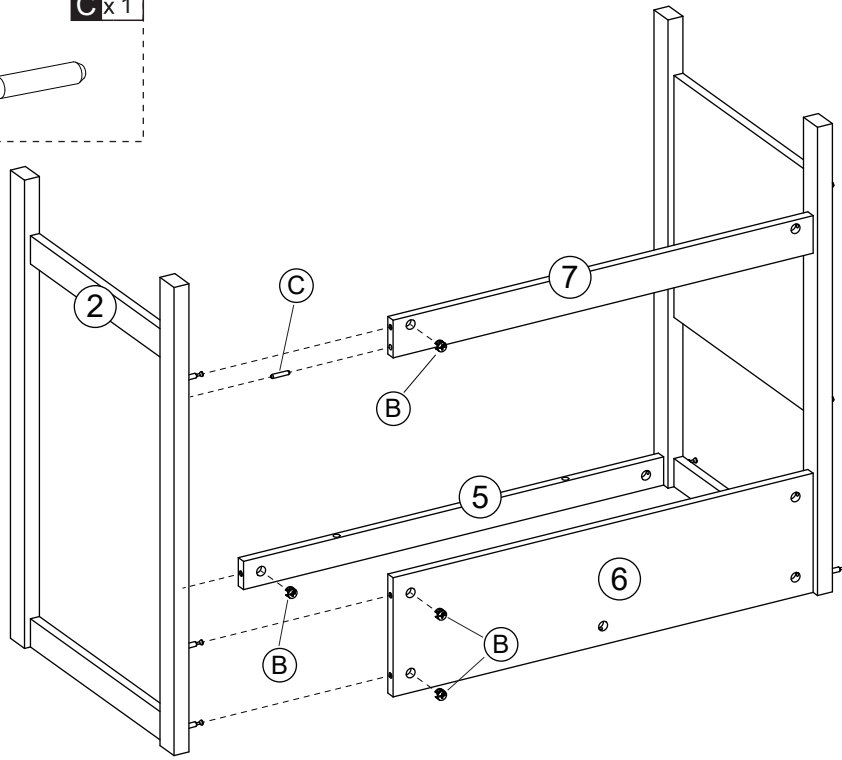
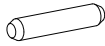

E x 2

J x 1

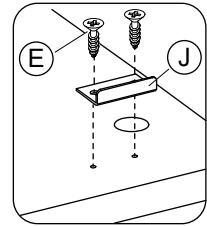
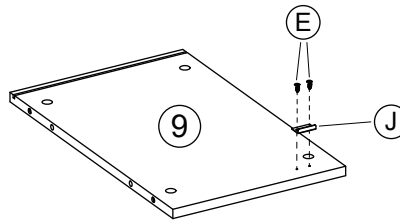

B x 6

C x 6

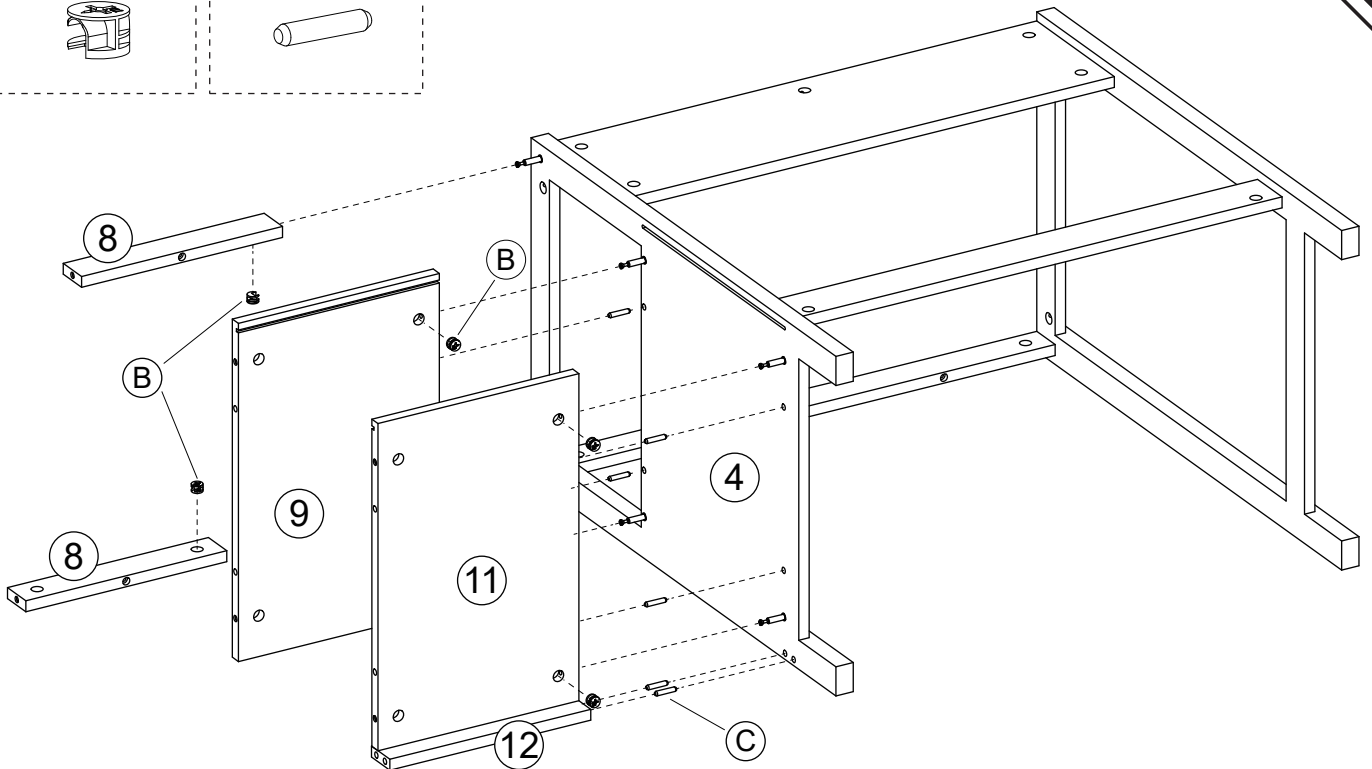

A x 6

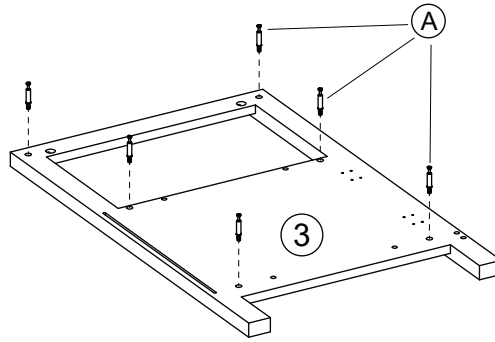
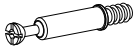

B x 6



C x 6

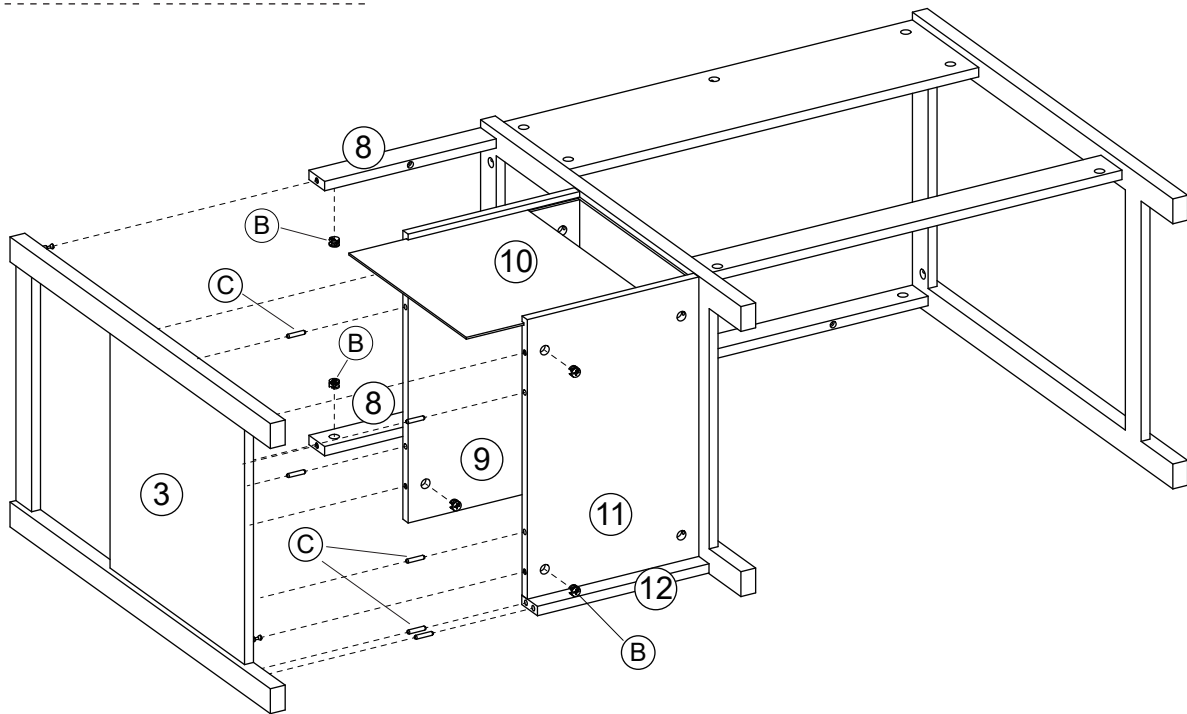

L x 6

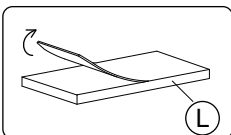
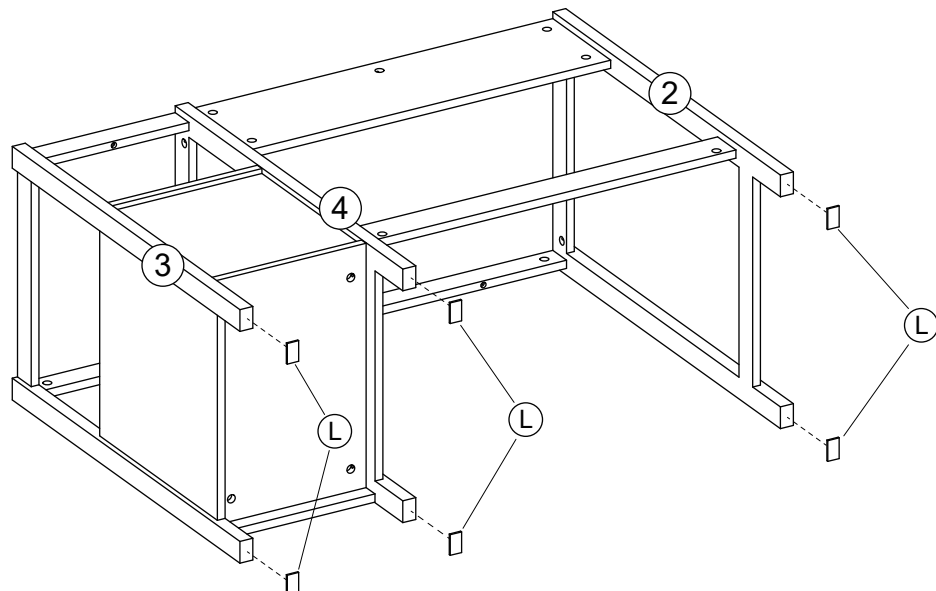

A x 7

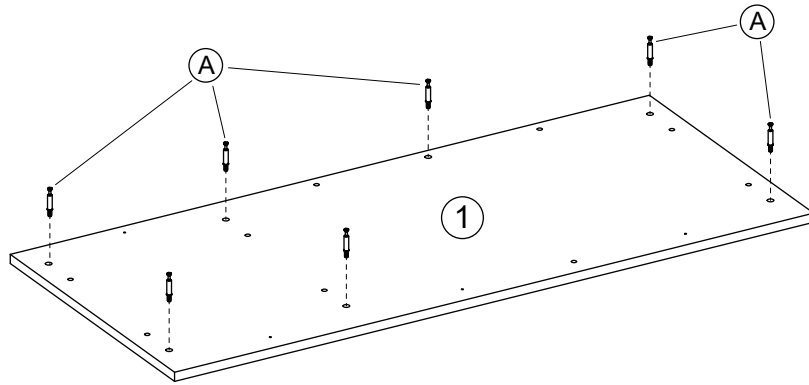
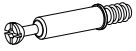

B x 7



C x 9



I x 4

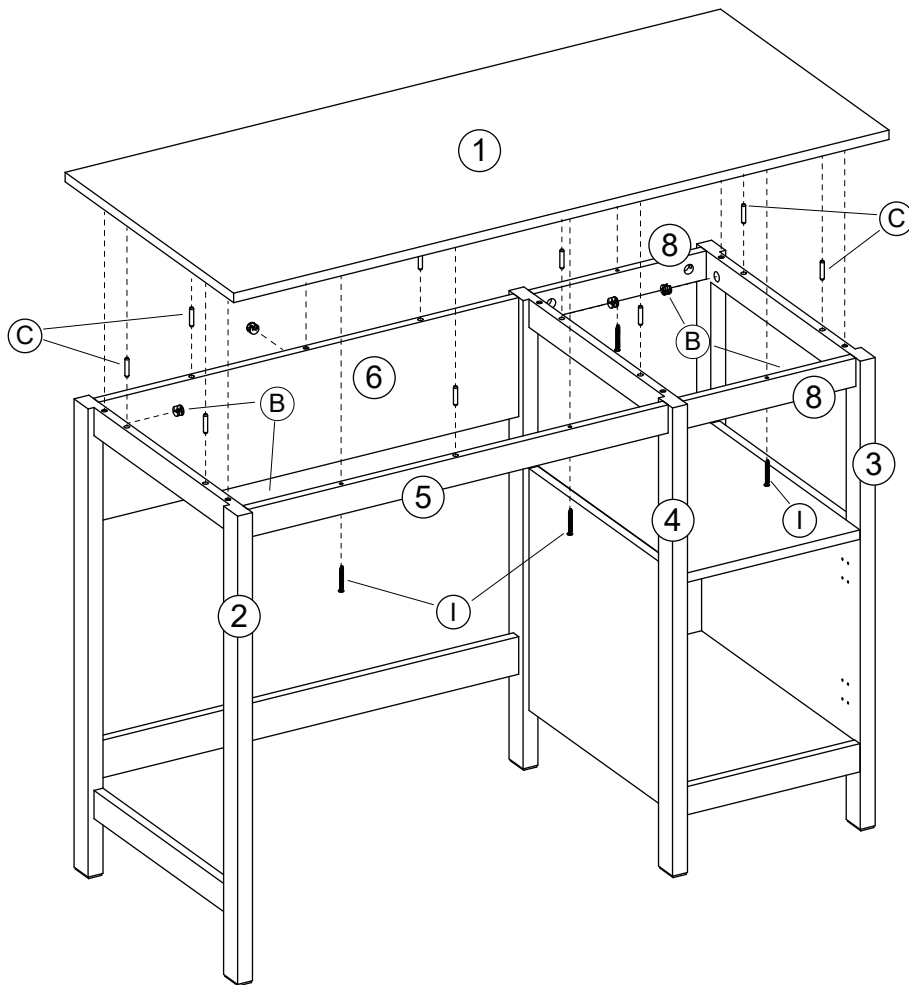

12

Kx4

Mx4

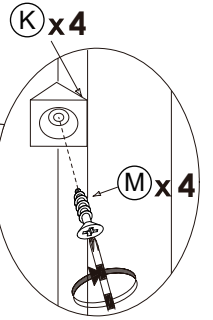
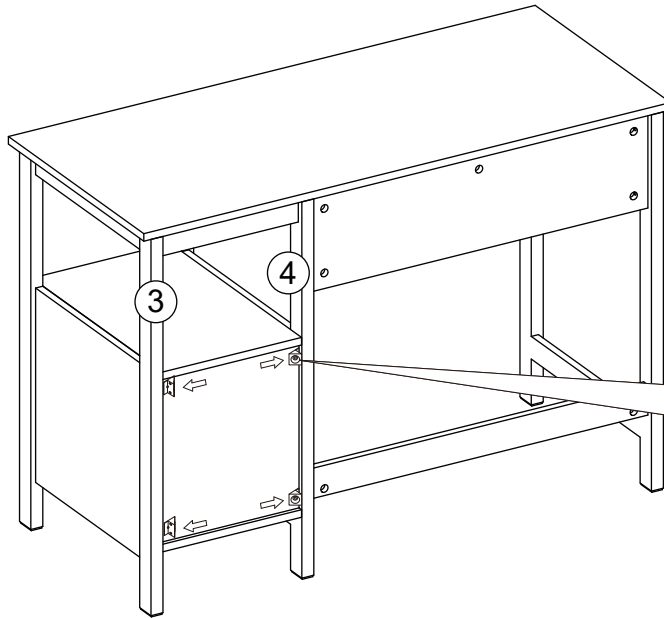

13

Dx2

Fx4

Gx1

Hx1

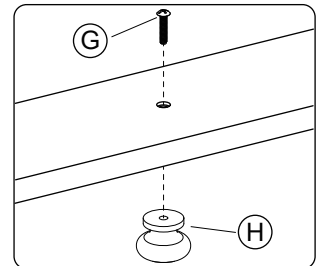
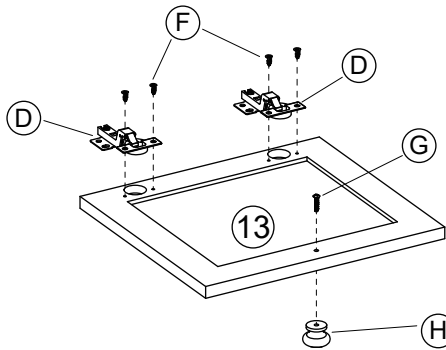
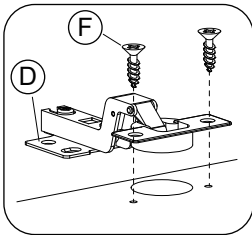
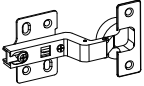

14

Fx8

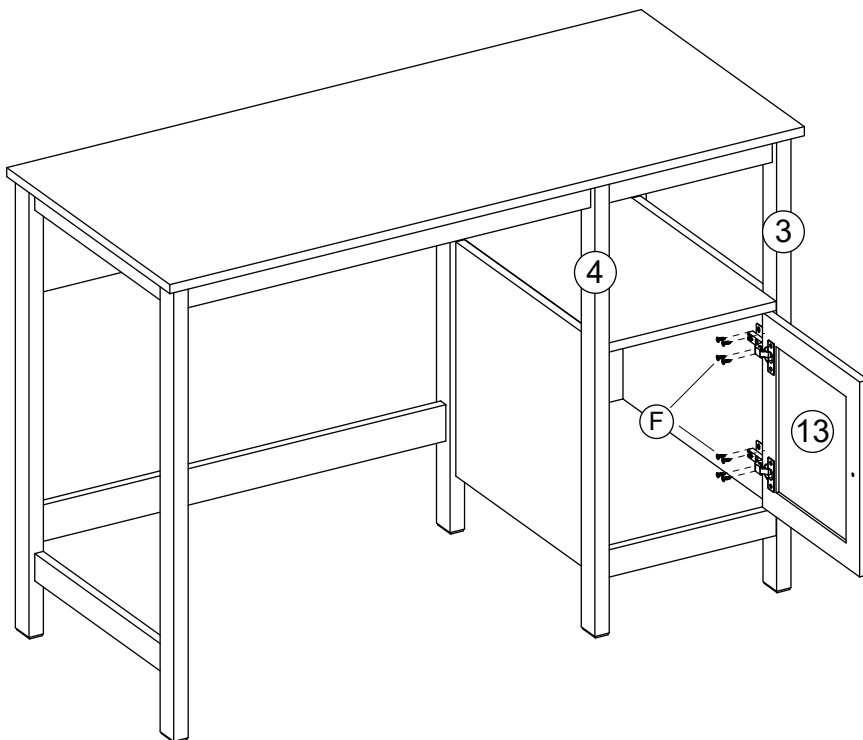

Done

INTENDED USE IN OFFICE OR HOME
ABOUT CARE AND MAINTENANCE OF TABLE :

1. To prevent the table from being scratched by hard objects, do not let metal objects break the surface of the table and leave bruise marks.
- 2, do not let the heat source has been baking, away from the source of fire. The surface should be fully considered to prevent dry cracking and deformation.
3. When in use, pay attention to the placement in a stable environment, otherwise there will be deformation.
- 4, prevent direct sunlight, can use gauze to prevent sunlight, so not only does not affect day lighting, but also can maintain the desk.
- 5, to check the desk, regularly clean up, remove the dust and corrosive gas and liquid, to prevent the desk
Corrosion affects the whole integrity of the table.
- 6, when using water to wipe the desktop, to wipe it clean, do not leave moisture on the desktop.
- 7, when cleaning to use a clean soft cloth, do not be too hard to wipe.

UTILISATION PRÉVUE POUR LE BUREAU OU LA MAISON
À PROPOS DE L'ENTRETIEN ET DE LA MAINTENANCE DE LA TABLE :

1. Pour éviter que la table ne soit rayée par des objets durs, ne laissez pas d'objets métalliques briser la surface de la table et laisser des marques d'ecchymoses.
2. Ne laissez pas la source de chaleur a été la cuisson, loin de la source de feu. La surface doit être entièrement considérée pour éviter les fissures sèches et les déformations.
3. Lors de l'utilisation, assurez-vous que la table soit placée dans un environnement stable, sinon il y aura des déformations.
4. Empêcher la lumière directe du soleil, vous pouvez utiliser une gaze pour protéger le bureau de la lumière directe du soleil, de sorte que non seulement l'éclairage de jour ne soit pas affecté, mais aussi que la table soit préservée.
5. Inspecter régulièrement la table, nettoyer et enlever la poussière ainsi que les matières corrosives (gaz et liquides) afin de prévenir la corrosion de la table.
La corrosion affecte l'intégrité entière de la table.
6. Lorsque vous utilisez de l'eau pour essuyer la table, nettoyez-la soigneusement, ne laissez pas de traces d'humidité sur la table.
7. Lorsque vous nettoyez le la table, utilisez un chiffon doux et propre, sans trop forcer.

PARA USARSE EN OFICINA Y HOGAR
CUIDADO Y MANTENIMIENTO DE LA MESA:

1. Tenga en cuenta de que los objetos duros metálicos pueden romper la superficie de la mesa y dejar marcas de magulladuras.
2. No ponga el producto cerca de la fuente de calor, y manténgalo lejos de la fuente de fuego. De lo contrario, puede producir grietas y deformaciones en la superficie.
3. Cuando no la utiliza, colóquela en un lugar estable, para evitar la deformación.
4. Puede usar una gasa para protegerla de la luz solar directa, lo cual no afecta la iluminación diurna, mientras tanto puede ofrecer protección a la mesa.
5. Regularmente revise y limpie la mesa, eliminando el polvo y las materias corrosivas, para proteger la mesa.
Las materias corrosivas pueden afectar la integridad de la mesa.
6. Después de limpiar la mesa con agua, tiene que secarla completamente. Tenga cuidado de no dejar humedad en la mesa.
7. Limpie la mesa con un paño suave y limpio, sin ejercer mucha fuerza.

VORGEGESEHENE VERWENDUNG IM BÜRO ODER ZU HAUSE ZUR PFLEGE UND WARTUNG DES TISCHES :

1. Um zu verhindern, dass der Tisch durch harte Gegenstände zerkratzt wird, vermeiden Sie, dass Metallgegenstände die Oberfläche des Tisches beschädigen und blaue Flecken hinterlassen.
2. Entfernen Sie die Wärmequelle für das Backen nicht von der Feuerquelle. Die Oberfläche sollte vollständig berücksichtigt werden, um Trockenrisse und Verformungen zu verhindern.
3. Wenn in Gebrauch, achten Sie auf die Aufstellung in einer stabilen Umgebung, sonst gibt es Verformungen.
4. Verhindern Sie direktes Sonnenlicht, Sie können Gaze verwenden, um Sonnenlicht zu verhindern, so dass nicht nur die Tagesbeleuchtung nicht beeinträchtigt wird, sondern auch der Schreibtisch erhalten werden kann.
5. Den Schreibtisch prüfen, regelmäßig aufräumen, den Staub und korrosives Gas und Flüssigkeit entfernen, um den Schreibtisch zu schützen.
Korrosion beeinträchtigt die gesamte Integrität des Tisches.
6. Wenn Sie Wasser verwenden, um den Schreibtisch zu wischen, um ihn sauber zu wischen, hinterlassen Sie keine Feuchtigkeit auf dem Schreibtisch.
7. Bei der Reinigung ein sauberes, weiches Tuch verwenden, nicht zu hart wischen.

DESTINAZIONE D'USO IN UFFICIO O A CASA CURA E MANUTENZIONE DELLA SCRIVANIA:

1. Per evitare che la scrivania venga graffiata da oggetti duri, non lasciare che gli oggetti metallici rompano la superficie della scrivania e lascino le tracce.
2. Non permettere che la fonte di calore la inforni, tenerla lontana dalla fonte di fuoco. La superficie dovrebbe essere considerata completamente per evitare crepe e deformazioni secche.
3. Quando è in uso, prestare attenzione al posizionamento in un ambiente stabile, altrimenti si verificherà una deformazione.
4. Prevenire la luce solare diretta. Si può utilizzare una garza per prevenire la luce solare in modo che non influisca sull'illuminazione diurna, ma possa anche mantenere la scrivania.
5. Controllare la scrivania, pulire regolarmente, rimuovere la polvere e il gas e il liquido corrosivi per mantenere che la scrivania.
La corrosione influenza l'intera integrità della scrivania.
6. Quando si utilizza l'acqua per pulire la superficie, non lasciare umidità sulla superficie.
7. Quando la pulisci, utilizza un panno morbido pulito, non pulirla con forza troppo forte.

IMPORTER ADDRESS**EN**

MH STAR UK LTD
 Unit 27, Perivale Park,
 Horsenden lane South
 Perivale, UB6 7RH
 MADE IN CHINA

IMPORTADOR**ES**

SPANISH AOSOM, S.L.
 C/ ROC GROS, Nº 15. 08550, ELS HOSTALET DE BALENYÀ, SPAIN.
 B66295775
 WWW.AOSOM.ES
 ATENCIONCLIENTE@AOSOM.ES
 TEL: 931294512
 HECHO EN CHINA

ADRESSE DES IMPORTEURE**DE**

MH Handel GmbH
 Wendenstraße 309
 D-20537 Hamburg
 Germany
 IN CHINA HERGESTELLT

IMPORTATO DA**IT**

AOSOM Italy srl
 Centro Direzionale Milanofiori
 Strada 1 Palazzo F1
 20057 Assago (MI)
 P.I.: 08567220960
 FATTO IN CINA

ADRESSE D'IMPORTATION**FR**

MH FRANCE
 2 Rue Maurice Hartmann
 92130 Issy Les Moulineaux
 France
 FABRIQUÉ EN CHINE

**FR**

**Pensez à
 donner ou recycler.**



Association

ou



Magasin

ou



Déchèterie

<https://quefairedemesdechets.fr>