

Soozier

IN221100396V01_US

A90-230

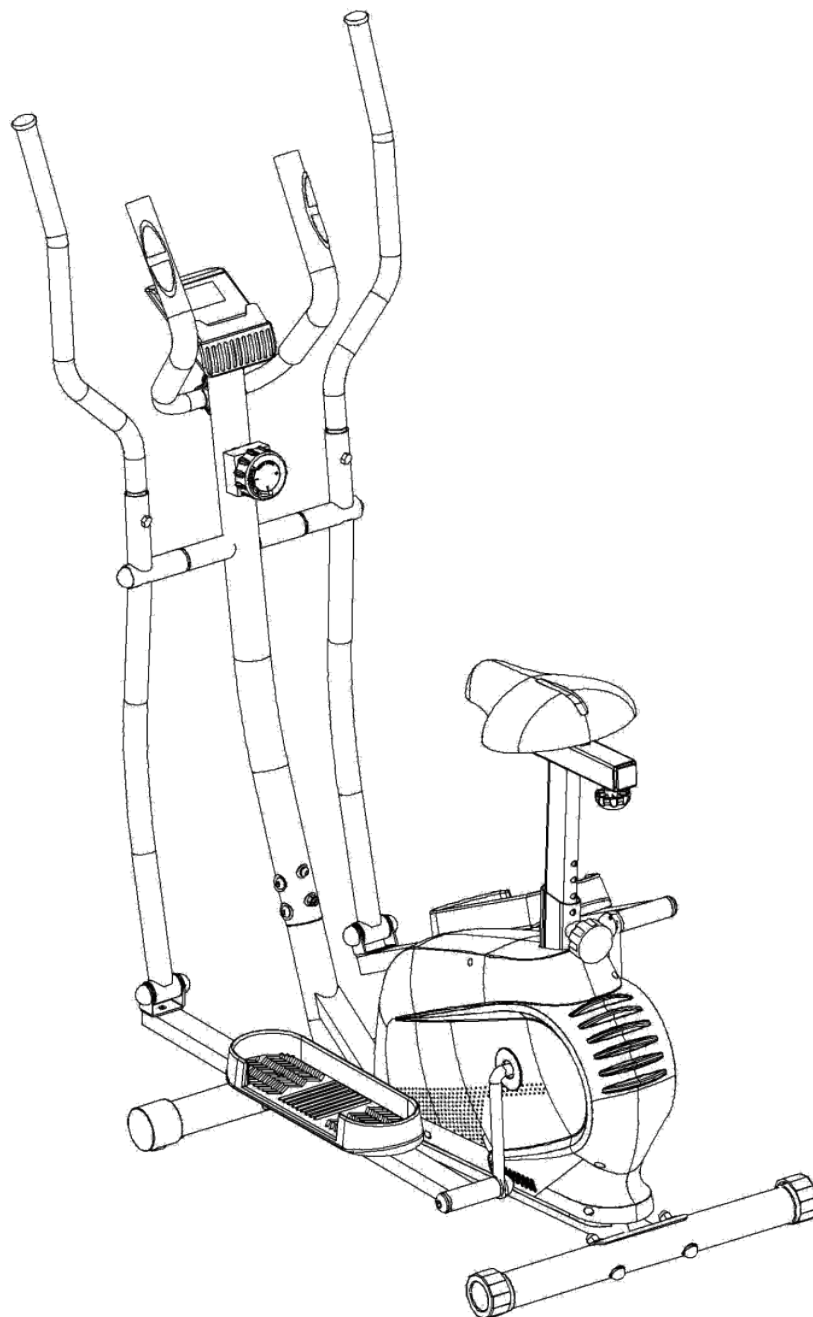



IMPORTANT, RETAIN FOR FUTURE REFERENCE: READ CAREFULLY

ASSEMBLY INSTRUCTION

Dear customer,

Thank you for purchasing this product. So that your appliance serves you well, please read all the instructions in this user's manual. If you have any questions, please contact our customer care center.

Our contact details are below:

Country	 Phone	 Email
US	001-877-644-9366	customerservice@aosom.com

IMPORTANT SAFETY INFORMATION

Please note the following safety precautions before exercising:

- 1、 Read all instructions before assembly & operation;
- 2、 Check all screws, nuts & other connections before using the bike;
- 3、 Do not expose the equipment to damp places, which will cause failure;
- 4、 When assembling, it is best to place parts on a mat (rubber or wood) to avoid soiling;
- 5、 Before exercise, make sure that no other items are placed within 2 meters around the equipment;
- 6、 Clean only with a damp cloth, do not use solvent cleaners and also note after each exercise should be wiped off the sweat on the equipment;
- 7、 Incorrect or excessive exercise can damage your health. It is recommended to consult a doctor before exercising. They will give you a maximum amount of training (including pulse, watts, duration, etc.) so that you can Exercise and get accurate information. Note: This equipment is not suitable for therapeutic use;
- 8、 only when the machine is in normal conditions to exercise, maintenance can only use the original accessories provide by the factory;
- 9、 This machine can only be used by one person at a time;
- 10、 Always wear sport clothes and sports shoes when exercising, especially the sports shoes must fit.
- 11、 If at any time during exercise you feel faint, dizzy or experience pain, stop and consult your physician.
- 12、 Children and disabled persons can only use when they are under guardianship;
- 13、 This bike has the function to let the resistance be adjusted for motion intensity. Make sure to adjust it to your preference.
- 14、 The maximum weight capacity of this unit is 100 kilograms.
- 15、 This equipment is designed for indoor use only!

Attention: Make sure all screws and nuts are tightened before Exercise

TIP: THE FRONT END CAP CAN BE MOVED, IT ALLOWS YOU TO MOVE THE BIKE.

EXPLODED DRAWING AND PARTS LIST

EXPLODED DRAWING AND HARDWARE PACKAGE No.1 :

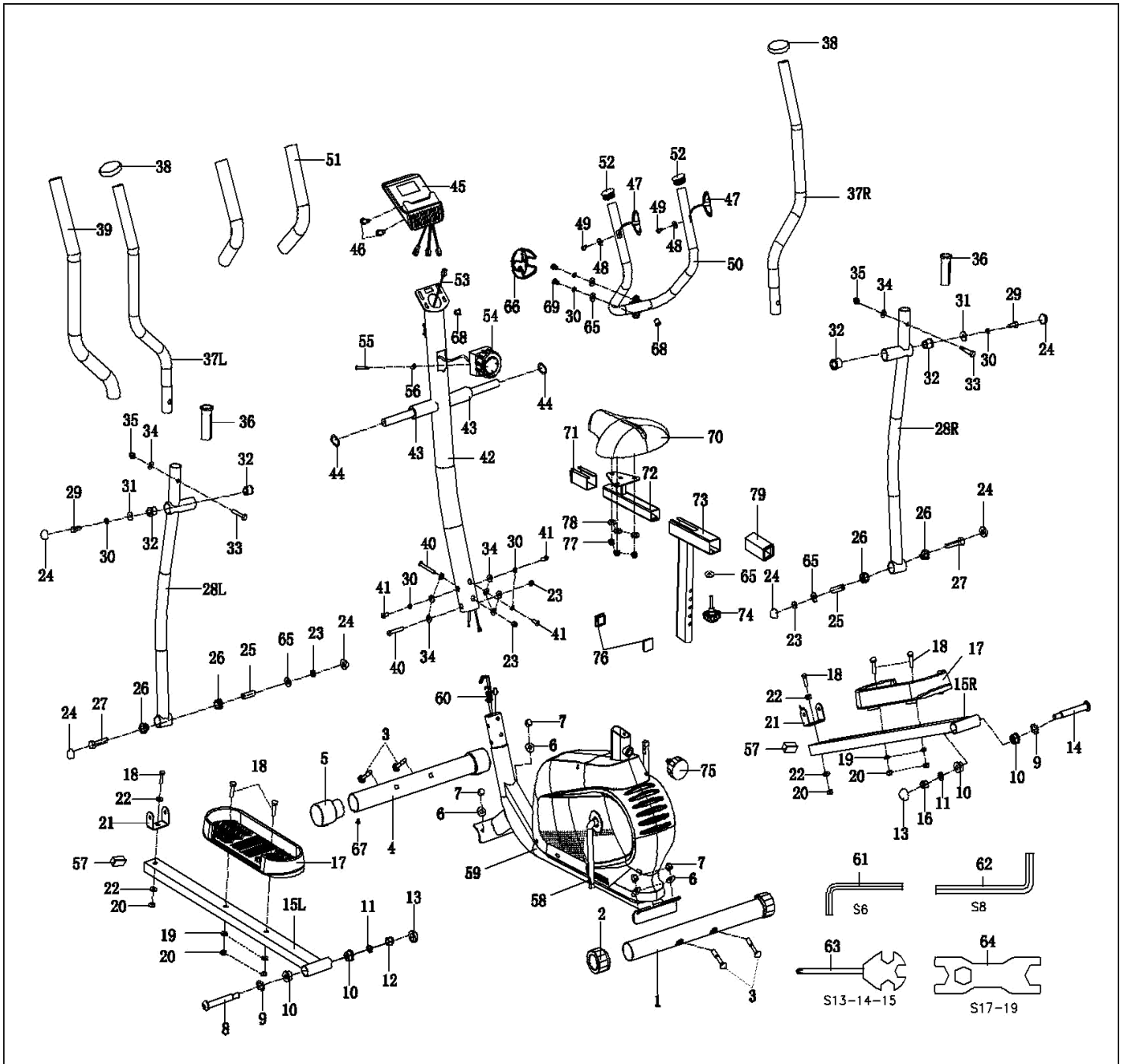

Parts List No.1 :

No.	Description	QTY	No.	Description	QTY
1	Rear Stabilizer	1	39	Foam Grip	2
2	Rear End Cap	2	40	Screw M8*60	2
3	Screw M10*57	4	41	Screw M8*20	3
4	Front Stabilizer	1	42	Front Post	1
5	Front End Cap	2	43	Bushing	2
6	Washer D10	4	44	Washer φ19	2
7	Nut M10	4	45	Monitor	1
8	Screwφ16x89x1/2"x20-L	1	46	Screw M5*10	2
9	Washer φ16	2	47	Hand Pulse	2
10	Bushing φ28	4	48	Washer φ6*φ12*1	2
11	Washer φ13	2	49	Screw ST4.2*20	2
12	Nylon Nut 1/2"x20- L	1	50	Middle Handle Bar	1
13	Cap S18	2	51	Foam Grip	2
14	Screw φ16x89x1/2"x20-R	1	52	Plug	2
15L	Pedal Tube-L	1	53	Middle Wire	1
15R	Pedal Tube-R	1	54	Tension Control	1
16	Nylon Nut 1/2"x20-R	1	55	Screw M5*40	1
17	Pedal	2	56	Washer D5	1
18	Screw M10x45	7	57	Plug	2
19	Washer φ10.5*φ20*2	4	58	Crank	1
20	Nylon Nut M10	6	59	Main Frame	1
21	U Shape Seat	2	60	Sensor Wire	1
22	Wash φ10.5*φ26*2	4	61	Wrench S6	1
23	Nylon Nut M8	4	62	Wrench S8	1
24	Cap S13	6	63	Wrench S13-14-15	1
25	Bushing	2	64	Wrench 17-19	2
26	Bushing φ32	4	65	Washer φ8.5*φ16*1.5	5
27	Screw M8x65	2	66	Plastic Cover	1
28L	Coupler Bar-L	1	67	Screw ST4.2*20	7
28R	Coupler Bar-R	1	68	Wire Plug Φ12	2
29	Screw M8*16	2	69	Screw M8*30	2
30	Washer D8	7	70	Seat Cushion	1
31	Washer φ8.5*φ32*2	2	71	Bushing	1
32	Bushing φ32	4	72	Adjust Tube	1
33	Screw M8*35	2	73	Seat Tube	1
34	Washer D8	9	74	Knob	1
35	Nut M8	2	75	Knob	1
36	Cushion	2	76	Plug	2
37L	Handle Bar-L	1	77	Nut M8	3
37R	Handle Bar-R	1	78	Washer φ8.5*φ19*1.5	3
38	Cap φ28	2	79	Cushion	1

EXPLODED DRAWING AND HARDWARE PACKAGE No.2:

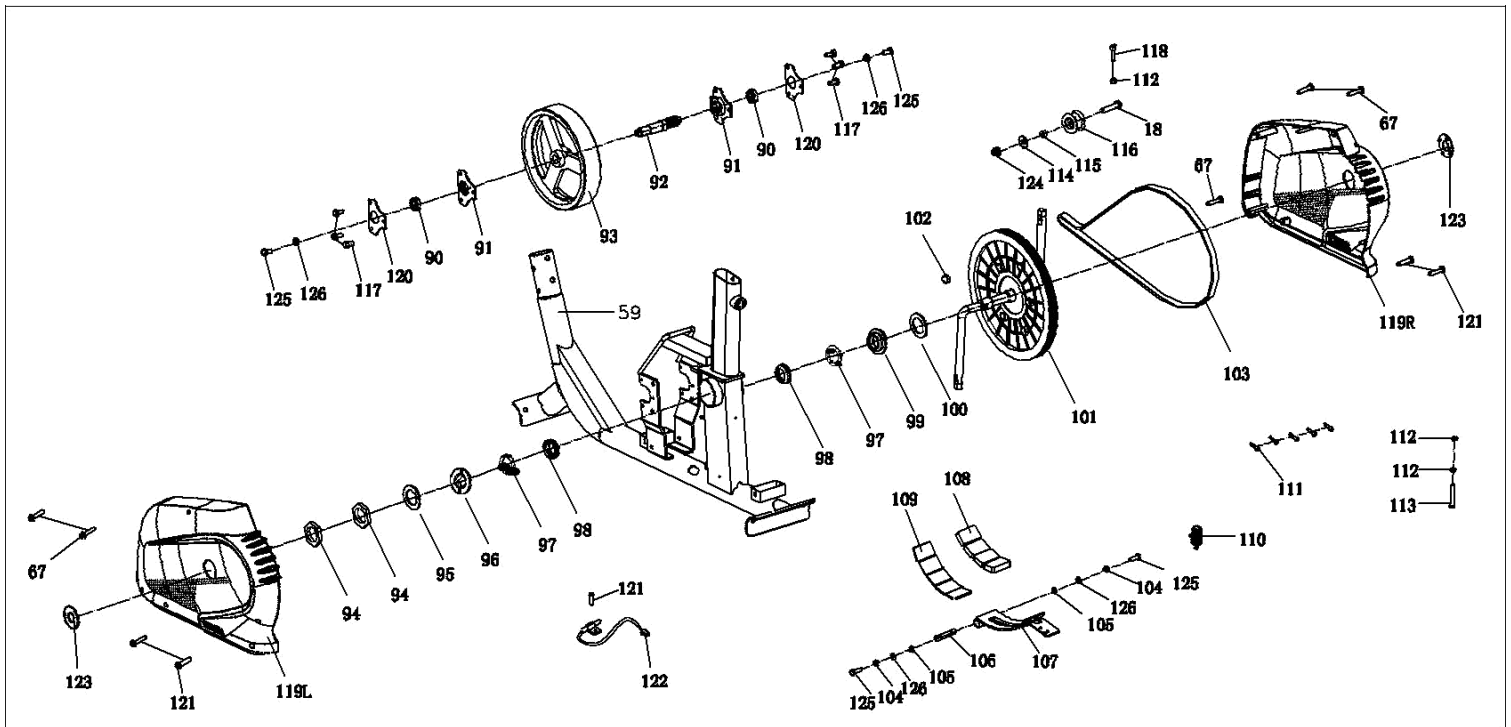

Part List No.2:

90	Bearing 6001RS	2	109	Magnet Grid	1
91	Bearing Seat	2	110	Spring	1
92	Inertial Axle	1	111	Screw ST3*10	5
93	Inertial Wheel	1	112	Nut M6	3
94	Nut	2	113	Screw M6*60	1
95	Washer	1	114	Washer $\phi 10.5 \times \phi 20 \times 2$	1
96	Nut	1	115	Bushing	1
97	Ball Shelf	2	116	Idler Wheel	1
98	Bowl	2	117	Screw M6*9	6
99	Nut	1	118	Screw M6*30	1
100	Washer	1	119 L	Chain Cover-L	1
101	Belt Pulley	1	119 R	Chain Cover-R	1
102	Magnetic	1	120	Bearing Plate	2
103	Belt 360PJ6	1	121	Screw ST4.2*16	5
104	Washer D6	2	122	Sensor	1
105	Ring D12	2	123	Hole Seal	2
106	Magnet Board Bearing	1	124	Nylon Nut M10	1
107	Magnet Board	1	125	Screw M6*15	4
108	Magnet	4	126	Washer $\phi 6.5 \times \phi 16 \times 1.5$	4

Assembly Instructions

1. Preparatory work:

- A. Make sure there is enough space before installation ;
- B. Confirm all of the components are all-ready before installation. (refer to previous product exploded view which indicates the name and the location of the components);
- C. Use the provided tools or the special self-contained tools to install.

2. Assembly instructions:

Step 1:

Screw Front and Rear Stabilizer (4&1) on Main Frame (59) with Screw (3), Washer (6) and Nut (7).

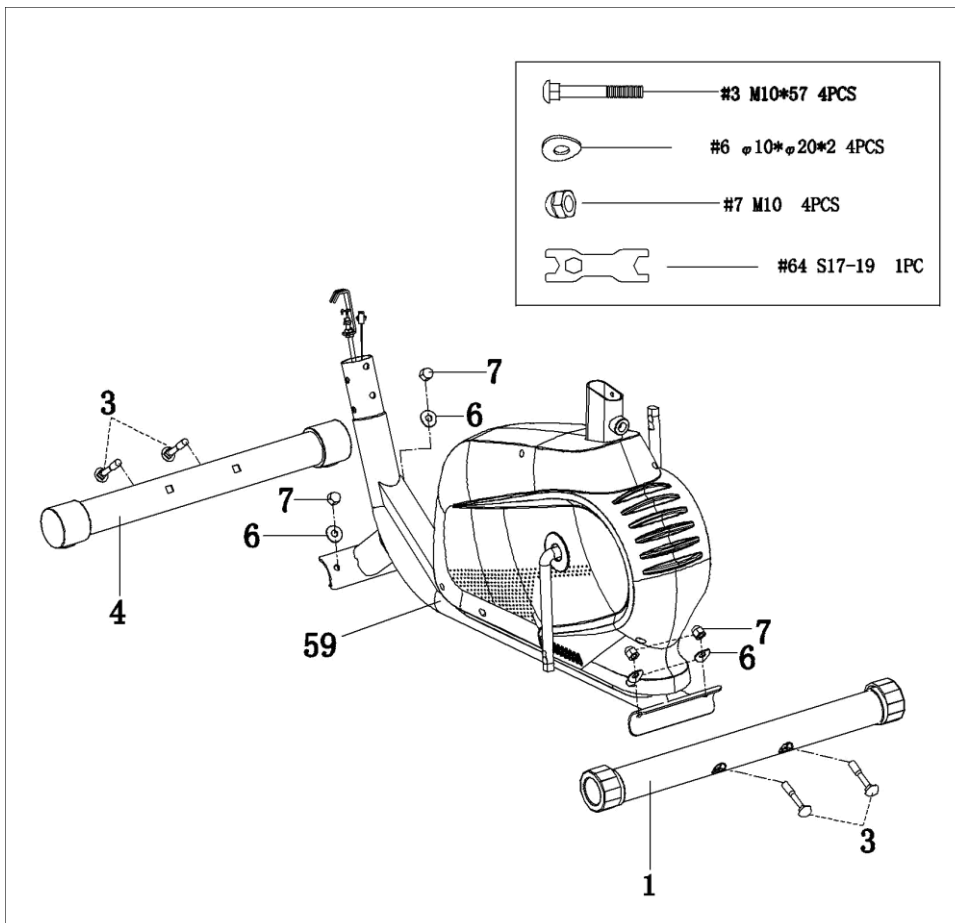

Step 2:



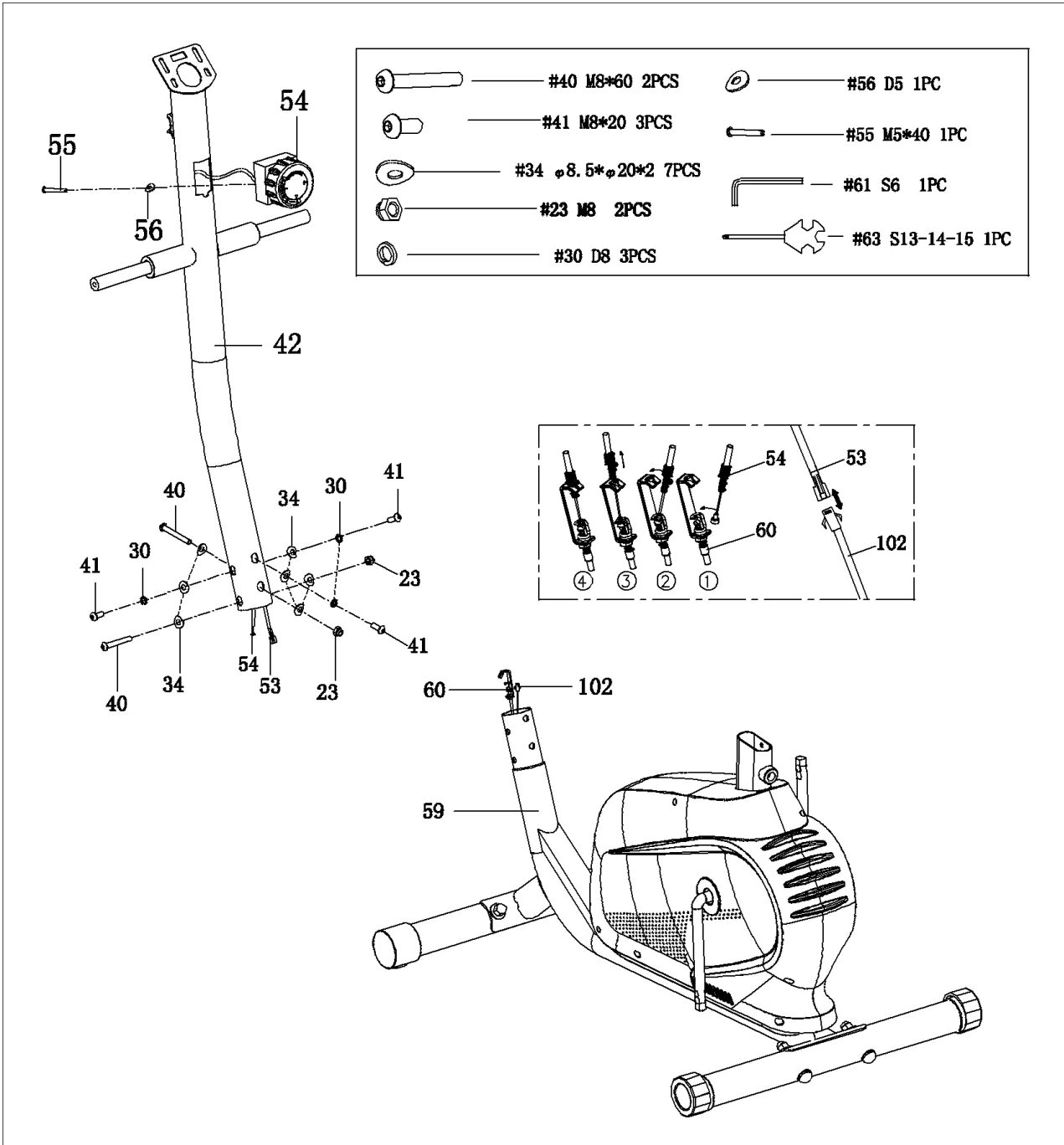







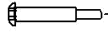

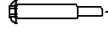

Screw Tension Control (54) on Front Post (42) with Washer (56) and Screw (55). Then connect Middle Wire (53) and Sensor Wire (102); and connect Tension Control (54) and Sensor Wire (60). Screw Front Post (42) on Main Frame (59) with Screw (40), Screw (41) Washer (30) Washer (34) and Nylon Nut (23).



Step 3:

Screw Coupler Bar(28L&R) on Front Post (42) with Screw (29), Washer (30), Washer (31) and cover with Cap (24); Screw Pedal Tube(15R) on Crank (58) with Screw (14), Washer (9), Washer (11), Nylon Nut (16) and Cover with Cap (13). Screw Pedal Tube (15L) on Crank (58) with the same operation.

Attn: The Screw of Pedal separate with L and R mark, Mark "R" should be clockwise, Mark "L" should be Counter-clockwise.

	#8 $\phi 16 \times 89 \times 1/2 \times S8$ 1PC		#43 $\phi 19 \times \phi 32 \times 75$ 2PCS		#24 S13 6PCS
	#14 $\phi 16 \times 89 \times 1/2 \times S8$ 1PC		#16 B0.5 1PC		#62 S8 1PC
	#29 M8*16* $S14$ 2PCS		#12 B0.5 1PC		#63 S13-14-15 1PC
	#31 $\phi 8.5 \times \phi 32 \times 2$ 2PCS		#11 D13 2PCS		#64 S17-19 1PC
	#30 D8 2PCS		#9 $d16 \times \phi 26 \times 0.3$ 2PCS		
	#44 $\phi 19 \times \phi 26 \times 0.3$ 2PCS		#13 S18 2PCS		

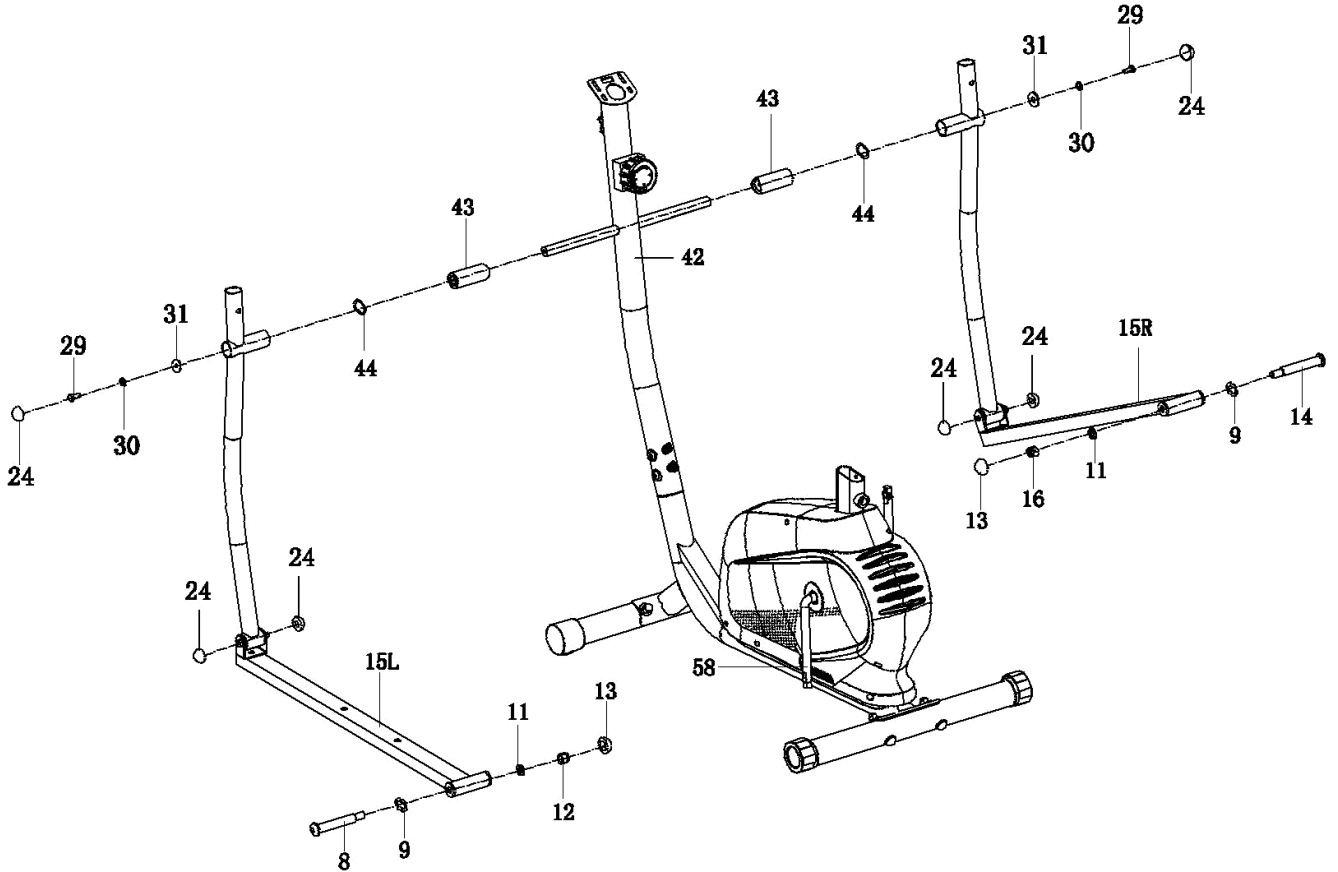

Step 4:

Screw Pedal (17) on Pedal Tube (15L&R) with Screw (18), Washer (19), Nylon Nut (20).

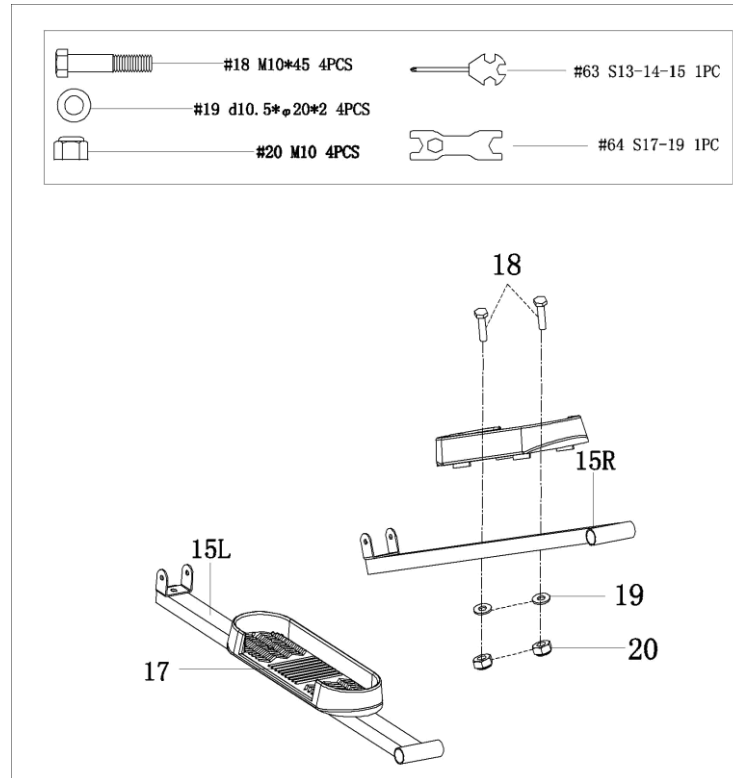

Step5:

Put the Wire Plug (68) out of Front Post (42), then put Hand pulse wire out of the Monitor Seat (42), then put Wire Plug (68) back to the hole of Front Post (42).

Then screw the Middle Handle bar (50) on Front Post (42) with Screw (69), Washer (30), Washer (65). Then connect Monitor (45) and Middle Wire (53), Hand Pulse (47), then screw Monitor (45) on Front Post (42) with Screw (46) and cover with Cap (66).

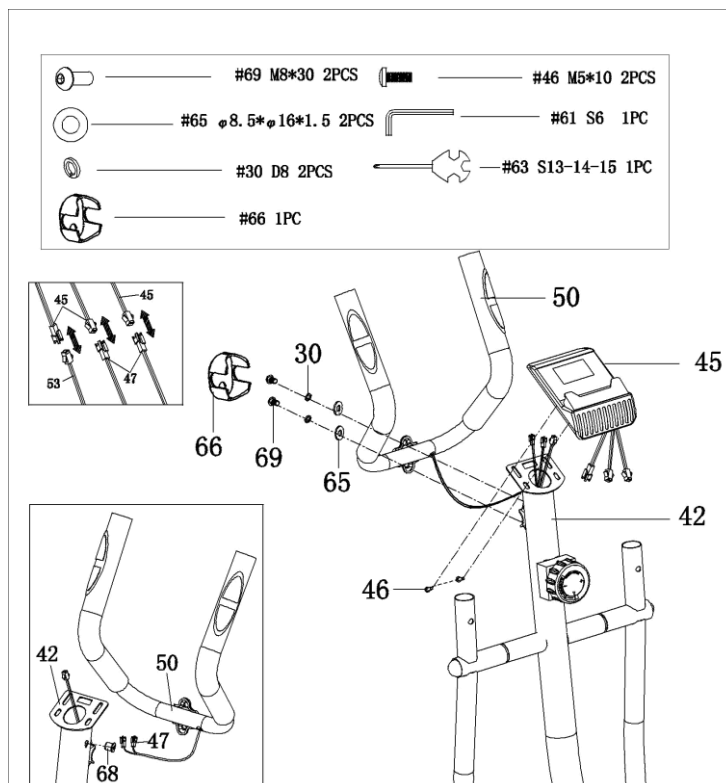

Step 6:

Screw Handle Bar(37L) into Coupler Bar(28L), align the holes and screw it with Screw(33), Washer(34) and Nut(35); Screw the Right Handle Bar(37R) as above operation.

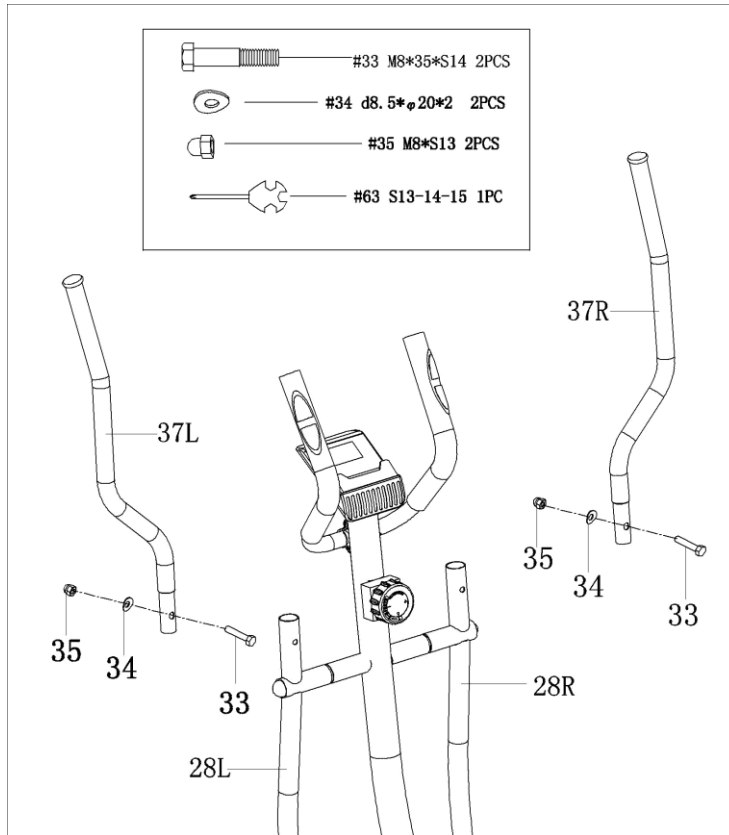

Step 7:

Pass the Adjust Tube (72) through Seat Tube (73). Knob (74) through Washer(65), Seat Tube(73) and screw it with Adjust Tube(72).

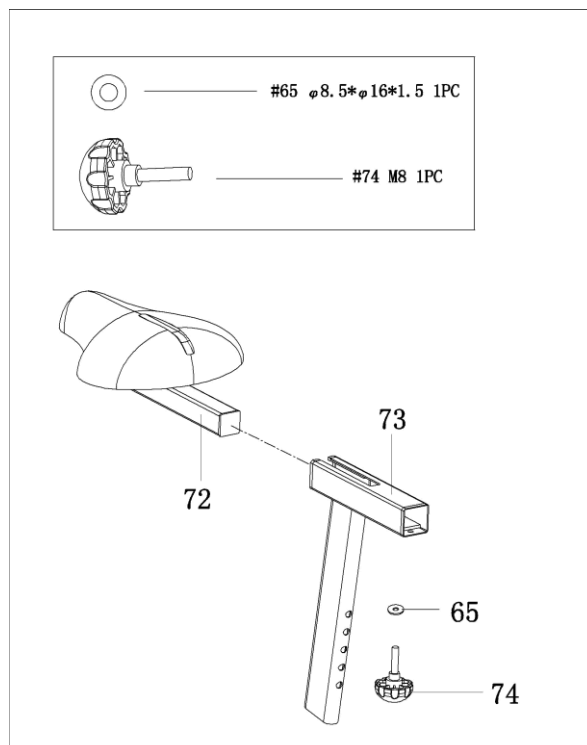

Step 8:

Screw Seat Tube (73) into Main Frame(59),Screw Knob(75) into Main Frame(59),the head of the knob(75) should be aligned with the Hole of Seat Tube(73).

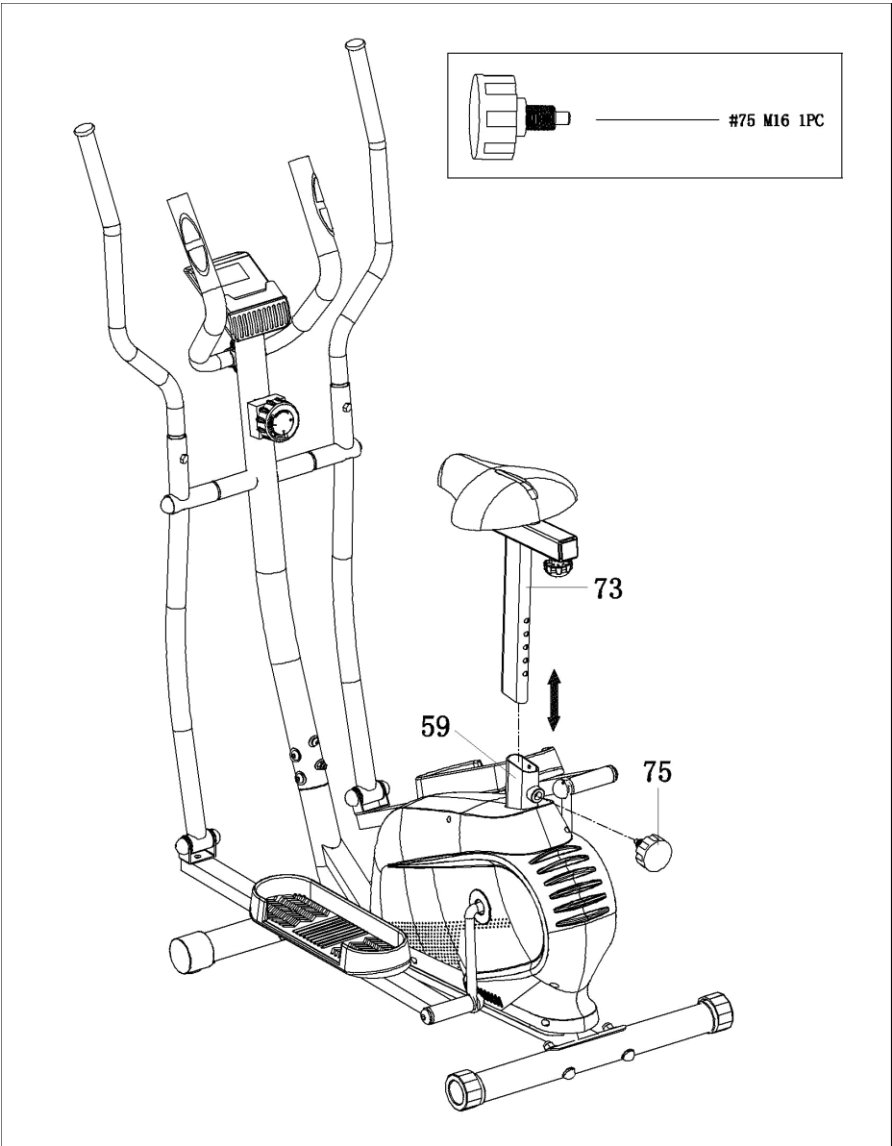

EXERCISE INSTRUCTIONS

The Warm Up Phase

This stage helps get the blood flowing around the body and the muscles working properly. It will also reduce the risk of cramp and muscle injury. It is advisable to do a few stretching exercises as shown below. Each stretch should be held for approximately 30 seconds, do not force or jerk your muscles into a stretch - if it hurts, STOP.

1. Down Stretch

Bend your knees slightly and body slowly, let your back and shoulders relax, and try to touch your toes. Keep it for 10 ~15 seconds, repeat 3 times.

2. Hamstring Stretch

Sitting on a clean cushion, then bend your right foot. Place your left foot against the inner thigh of your right foot. Try to touch your toes. Keep it for 10 ~15 seconds, repeat each foot 3 times.

3. Calf and Foot Stretching

Stand and place both hands on a wall or a tree, one foot behind. Keep the behind foot stand and it's heel on the floor, then tilt to the wall or tree. Keep it for 10 ~15 seconds, repeat each foot 3 times.

4 Quadriceps Stretch

Place your left hands against a wall or a desk to aid your balance. Then grasp your ankle with your left hand and pull your foot toward your buttocks. Keep it for 10 ~15 seconds, repeat each foot 3 times.

5. Groin Stretch

Sit with your knees flexed and soles of feet together. Hold your ankles and bend at your hips. Keep it for 10 ~15 seconds, repeat 3 times.

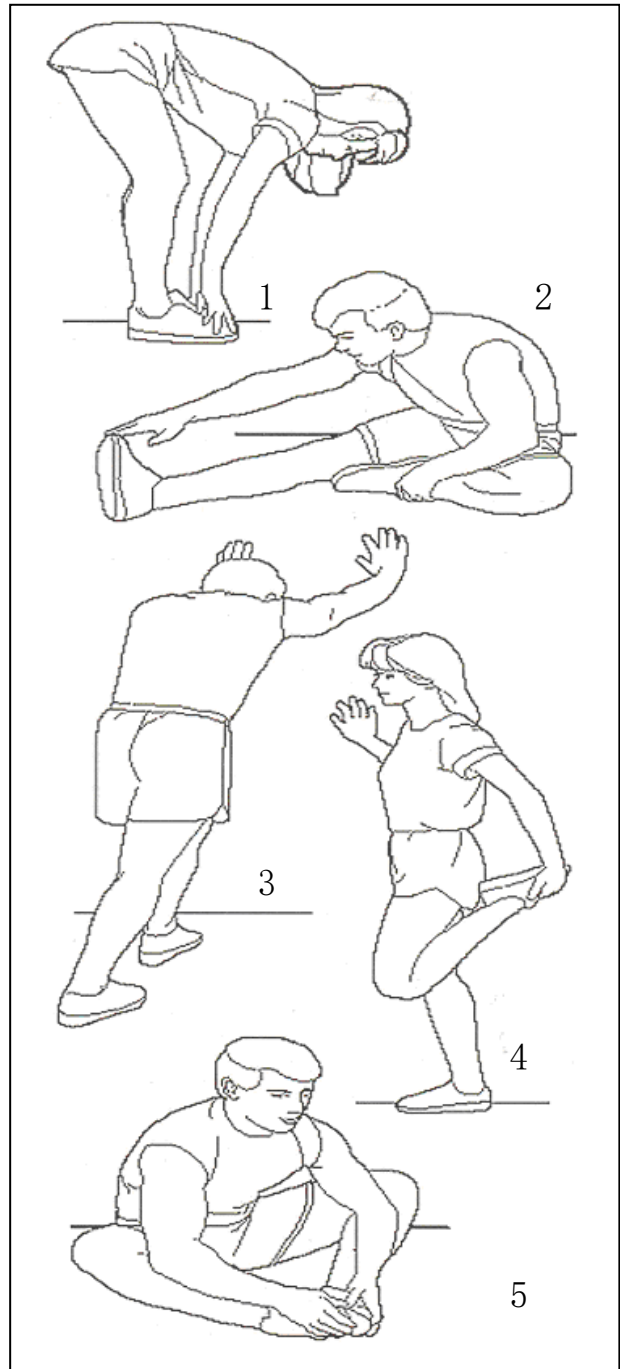

Exercise Stage

This stage should last for a minimum of 12 minutes though most people start at about 15~20 minutes. After times, you can increase training strength. After exercising for a period of time, your heart rate will be close to the “target zone”(shaded part) in the graph as shown below. **Note:** Getting in a better shape will not happen overnight and will require working out consistently.

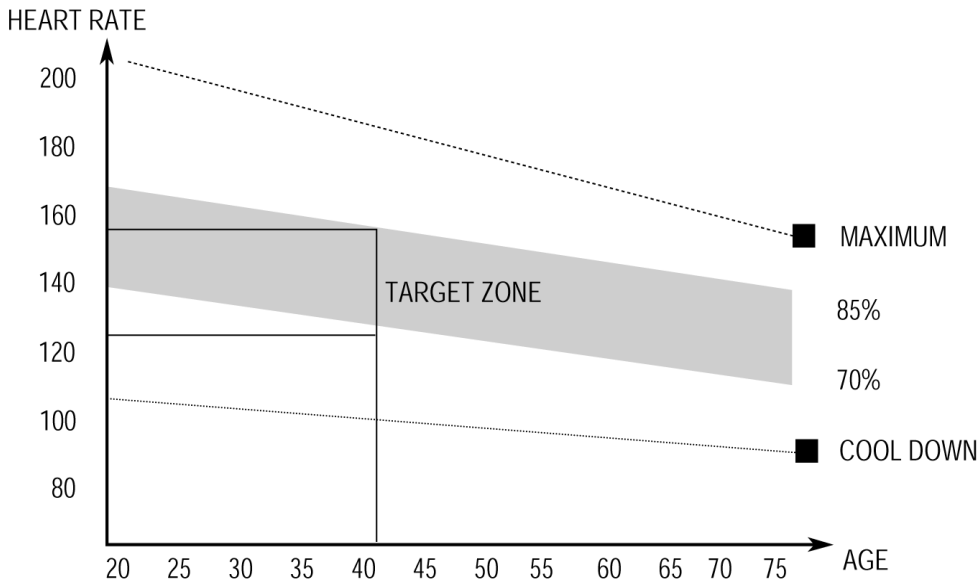

Recovery Phase

This stage is to let your Cardiovascular System and muscles wind down. This is a repeat of the warm up exercise e.g. reduce your tempo, continue for approximately 5 minutes. Then repeat the exercise phase, please be careful not to force or jerk your muscles.

When using elliptical fitness exercises, please don't increase training intensity arbitrarily. It may sprain your leg muscles, which means you can't continue exercising for a long time.

Equipment Tip

Adjusting the Tension Control can change the resistance of the equipment, the higher resistance the harder it is to step. Users can use this to find a suitable speed.