

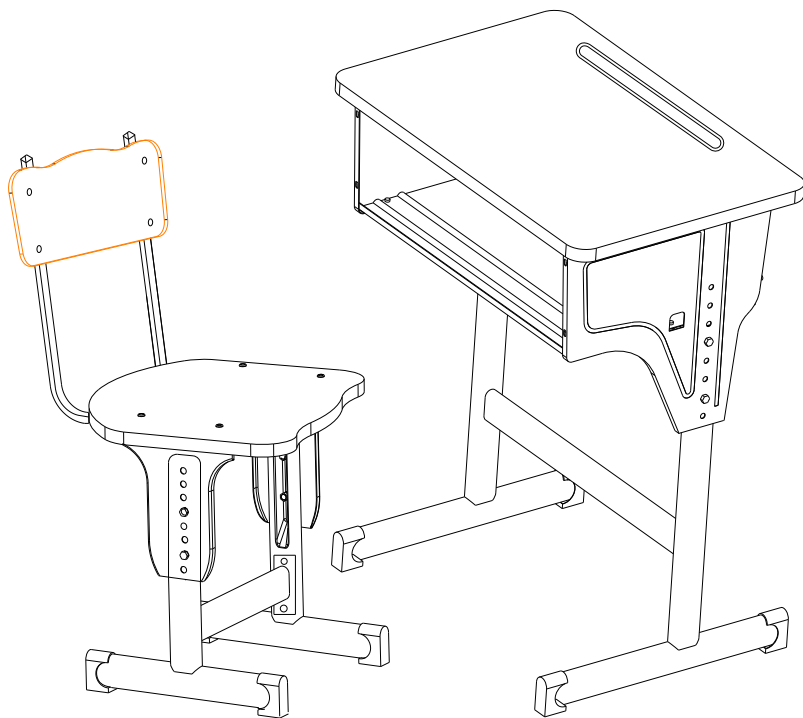

IN221100559V01_UK_FR_DE_ES_IT

312-065



EN_IMPORTANT, RETAIN FOR FUTURE REFERENCE: READ CAREFULLY.

FR_IMPORTANT: A LIRE ATTENTIVEMENT ET À CONSERVER POUR CONSULTATION ULTÉRIEURE.

ES_IMPORTANTE, LEA Y GUARDE PARA FUTURAS REFERENCIAS.

DE_WICHTIG! SORGFÄLTIG LESEN UND FÜR SPÄTER NACHSCHLAGEN AUFBEWAHREN.

IT_IMPORTANTE! CONSERVARE IL PRESENTE MANUALE PER FUTURO RIFERIMENTO E LEGGERLO ATTENTAMENTE.

WARNING:

- **CHOKING HAZARD—Small parts.** Not for children under 3 years.
- Only allowed for adults to install, keep children away.
- Place it on a flat and clean floor, Check all the parts are well connected before use.
- This product is suitable for kids aged from 6 to 12.
- Maximum Weight Capacity of Table: 80 Kg; Maximum Weight Capacity of Chair: 100Kg
- Please be extra careful and operate correctly when adjusting the height and the desk board.
- Keep away from fire!

MAINTENANCE & CARE

- Traces left by water-based pens such as pencils, pens, and water color pens can be wiped with water.
- Traces left by oily pen can be wiped by alcohol and balm.
- The desk board is moisture proof and scratch-resistant, But please do not use any blade to scratch it.
- Keep all instructions and parts relating to this product for future reference.

WARNUNG:

- **ERSTICKUNGSGEFAHR-Kleine Teile.** Nicht für Kinder unter 3 Jahren geeignet.
- Die Montage darf nur von Erwachsenen vorgenommen werden, halten Sie Kinder fern.
- Stellen Sie es auf einen flachen und sauberen Boden. Prüfen Sie, ob alle Teile vor der Verwendung gut verbunden sind.
- Dieses Produkt ist für Kinder von X bis X Jahren geeignet.
- Capacidad máxima de peso de la silla: 100 Kg; Capacidad máxima de peso de la mesa: 80 Kg.
- Dieses Produkt kann nur von Erwachsenen zusammengebaut werden.
- Bitte seien Sie besonders vorsichtig und arbeiten Sie richtig, wenn Sie die Höhe und die Tischplatte einstellen.
- Halten Sie es von Feuer fern!

WARTUNG & PFLEGE

- Spuren von Stiften auf Wasserbasis, wie Bleistifte, Kugelschreiber und Aquarellstifte, können mit Wasser abgewischt werden.
- Spuren von öligen Stiften können mit Alkohol und Balsam abgewischt werden.
- Die Tischplatte ist feuchtigkeitsgeschützt und kratzfest, aber bitte verwenden Sie keine Klinge, um sie zu zerkratzen.
- Bewahren Sie alle Anweisungen und Teile, die sich auf dieses Produkt beziehen, zur späteren Verwendung auf.

ADVERTENCIA:

- PELIGRO DE ASFIXIA: Incluidas piezas pequeñas. No es adecuado para los niños menores de 3 años.
- La instalación sólo se puede realizar por los adultos, mantenga a los niños alejados al instalar el producto.
- Colóquelo sobre un piso plano y limpio. Verifique si todas las piezas estén conectadas adecuadamente antes de utilizarlo.
- Este producto es pto para los niños de 3+ años.
- Maximale Gewichtskapazität des Stuhls: 100 Kg; Maximale Gewichtskapazität des Tisches: 80 Kg
- Tenga mucho cuidado y opérelo de manera correcta al ajustar la altura y el tablero de escritorio.
- ¡Mantenga el producto alejado del fuego!

MANTENIMIENTO Y CUIDADO

- Los rastros dejados por los bolígrafos a base de agua , por ejemplo, lápices, plumas y plumas de acuarela se pueden limpiar con agua.
- Los rastros dejados por los bolígrafos a base de aceite se pueden limpiar con alcohol y bálsamo.
- El tablero de escritorio es a prueba de humedad y resistente a los arañazos, sin embargo, no utilice ninguna hoja de cuchilla para rayarlo.
- Guarde todas las instrucciones y piezas relativas juntas con este producto para las referencias futuras.

AVVERTENZE:

- **RISCHIO DI SOFFOCAMENTO — Parti piccole.** Non adatte a bambini sotto i 3 anni.
- Consentito solo agli adulti di installare, tenere lontani i bambini.
- Posizionaelo su una superficie piana e pulita, controllare che tutte le parti siano connesse correttamente prima dell'uso.
- Questo prodotto è adatto a bambini di età tra 6 e 12 anni.
- Capacità massima della sedia: 100 Kg; Capacità massima del tavolo: 80Kg.
- Si prega di prestare la massima attenzione e di operare correttamente durante la regolazione dell'altezza e del piano della scrivania.
- Tenere lontano dal fuoco!

MANUTENZIONE & CURA

- Le tracce lasciate da penna a base d'acqua come matite, penne e pennarelli ad acqua possono essere pulite con acqua.
- Le tracce lasciate dalla penna oleosa possono essere eliminate con alcool e balsamo.
- La scrivania è resistente all'umidità e ai graffi, ma si prega di non utilizzare alcuna lama per graffiarla.
- Conservare tutte le istruzioni e le parti relative a questo prodotto per riferimenti futuri.

AVERTISSEMENT:

- **RISQUE D'ÉTOUFFEMENT - Petites pièces.** Déconseillé aux enfants de moins de 3 ans.
- Installation par des adultes uniquement, tenir les enfants à l'écart.
- Posez-le sur un sol plat et propre. Vérifiez que toutes les pièces sont bien connectées avant toute utilisation.
- Ce produit convient aux enfants âgés de 6 à 12 ans.
- Poids maximal admissible de la table: 80 Kg; Poids maximum admissible de la chaise: 100Kg.
- Veuillez faire très attention et opérer correctement lors du réglage de la hauteur et du plateau du bureau.
- Loin du feu !

ENTRETIEN ET MAINTENANCE

- Les traces laissées par des stylos à base d'eau tels que les crayons, les stylos et les stylos de couleur à l'eau peuvent être essuyées avec de l'eau.
- Les traces laissées par un stylo gras peuvent être essuyées par de l'alcool et du baume.
- La planche de bureau est résistant à l'humidité et aux rayures, Mais veuillez ne pas utiliser de lame pour le gratter.
- Conservez toutes les instructions et les pièces relatives à ce produit pour pouvoir vous y référer ultérieurement.



FR

**Pensez à
donner ou recycler.**

Association

ou



Magasin

ou



Déchèterie

<https://quefairedemesdechets.fr>

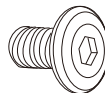
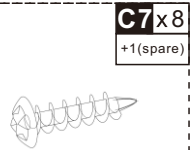
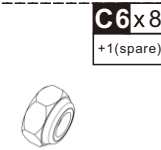
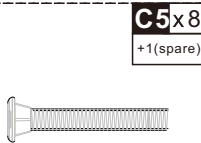
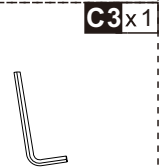
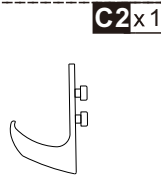
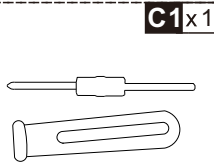
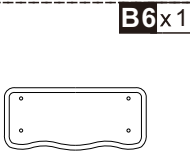
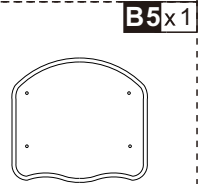
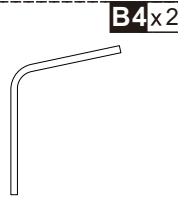
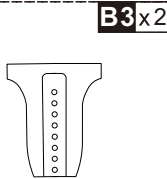
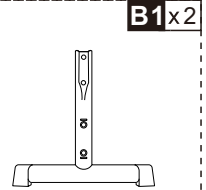
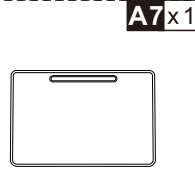
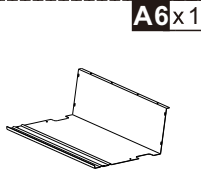
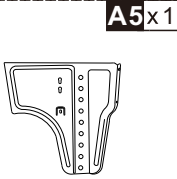
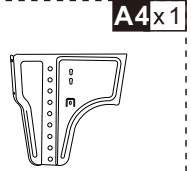
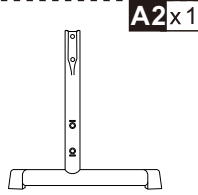
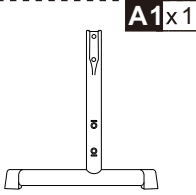

**Desk Assembly /Assemblage du Bureau/Montage des Tables/
Montaje de escritorio/ Assemblaggio della Scrivania:**

C10 x 4

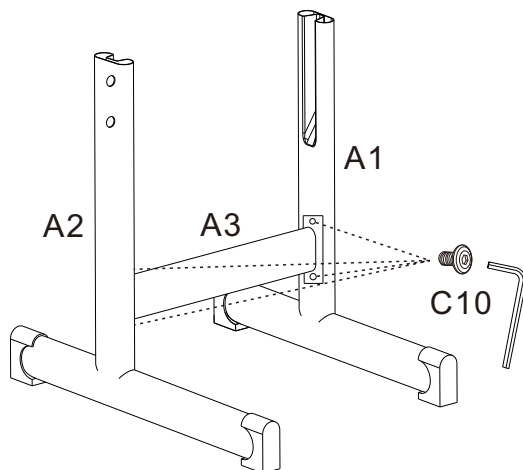

C9 x 4
C10 x 4

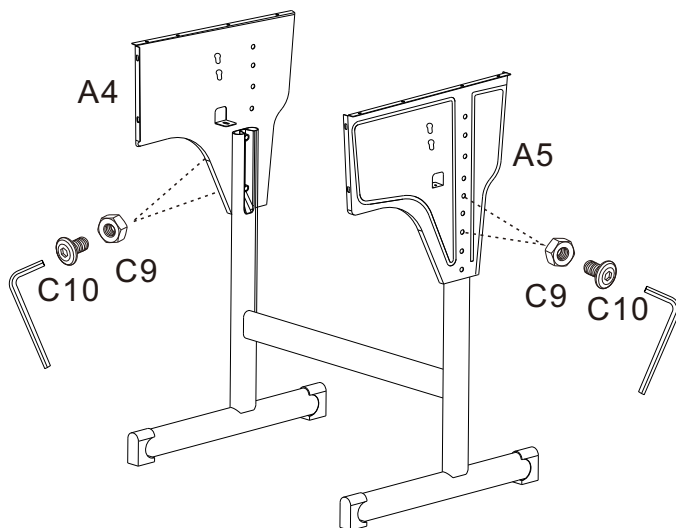

EN: Adjustable height according to hole position.

FR: Hauteur réglable en fonction de la position du trou.

DE: Einstellbare Höhe je nach Lochposition.

ES: Se puede ajustar la altura según la posición de los agujeros.

IT: Altezza regolabile in base alle posizioni dei fori.

C8 x 8
C11 x 8

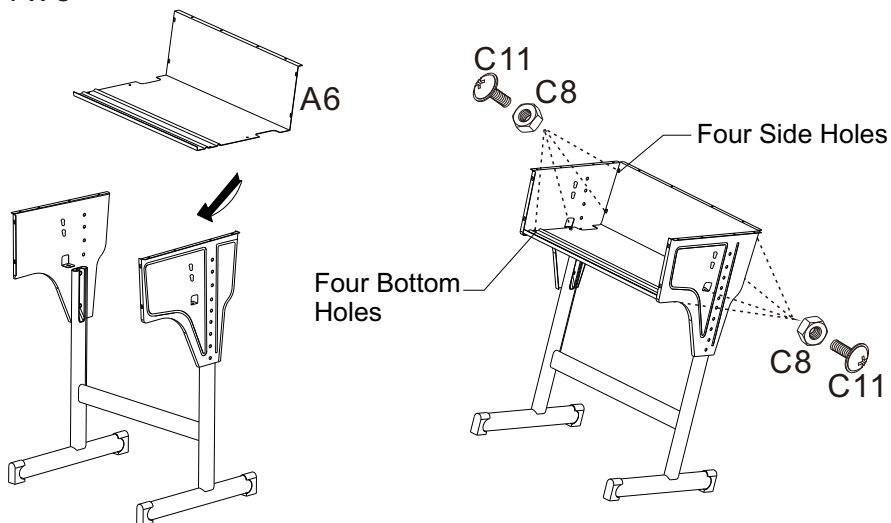

C7 x 8

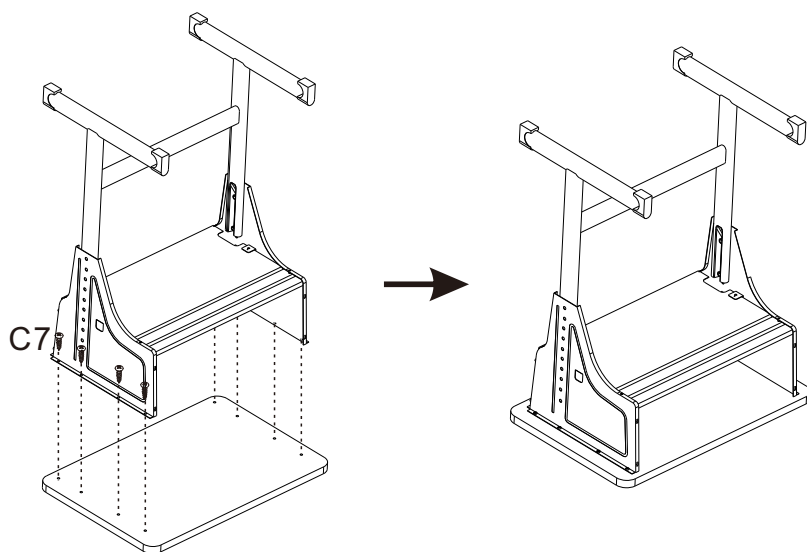

**Chair Assembly/Assemblage de la Chaise/Zusammenbau des Stuhls
/Montaje de silla/Assemblaggio della scrivania:**

C10 x 4

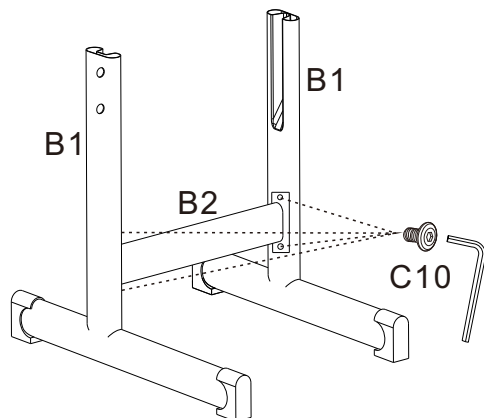

C9 x 4
C10 x 4

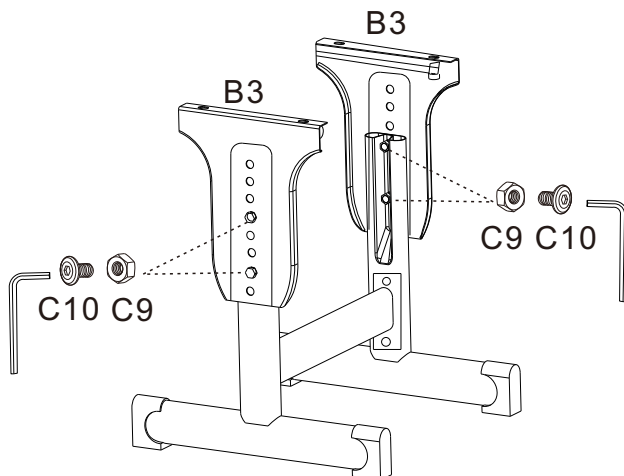

EN: Adjustable height according to hole position.

FR: Hauteur réglable en fonction de la position du trou.

DE: Einstellbare Höhe je nach Lochposition.

ES: Se puede ajustar la altura según la posición de los agujeros.

IT: Altezza regolabile in base alle posizioni dei fori.

C5 x 4
C6 x 4

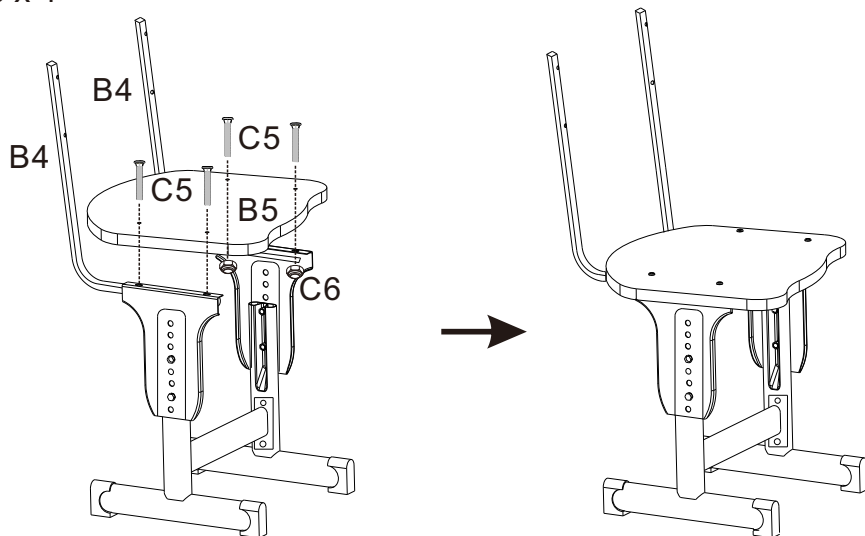

C5 x 4
C6 x 4

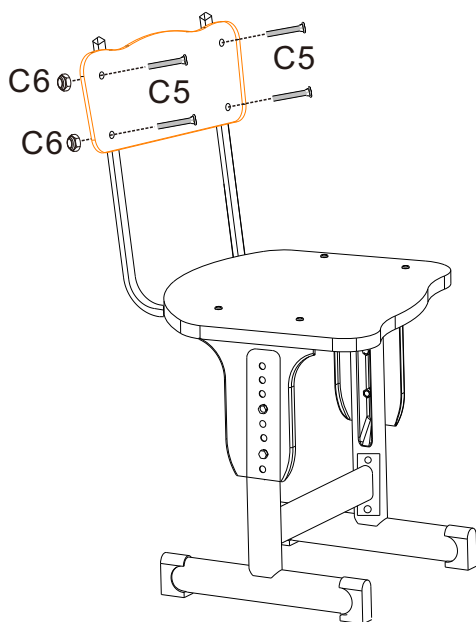

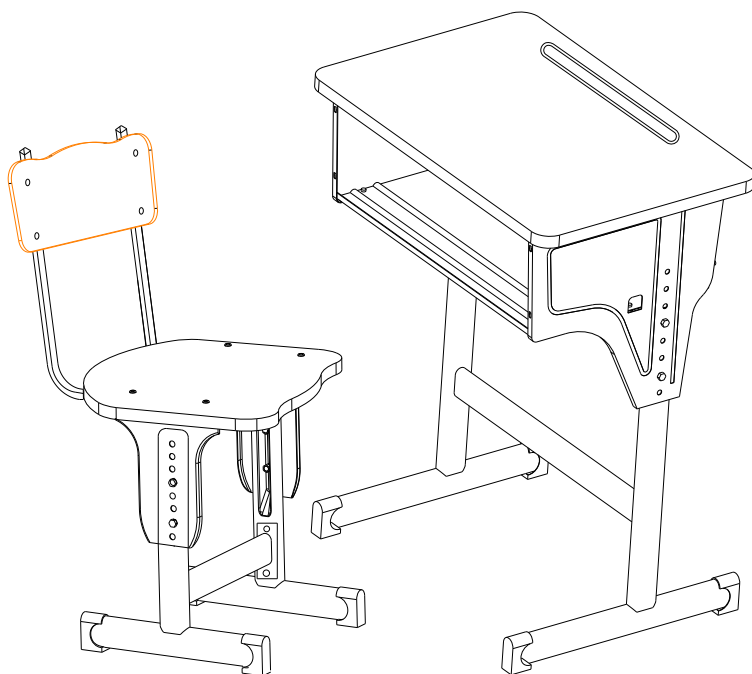

UK

If you have any questions, please contact our customer care center.

Our contact details are below:



0044-800-240-4004



enquiries@mhstar.co.uk

IMPORTER ADDRESS:

MH STAR UK LTD

Unit 27, Perivale Park,

Horsenden lane South

Perivale, UB6 7RH

MADE IN CHINA

ES

Si tiene alguna pregunta, comuníquese con nuestro Centro de Atención al Cliente.

Nuestros datos de contacto son los siguientes:



0034-931294512



atencioncliente@aosom.es

IMPORTADOR:

SPANISH AOSOM, S.L.

C/ ROC GROS, N° 15. 08550, ELS HOSTALET DE

BALENYÀ, SPAIN.

B66295775

WWW.AOSOM.ES

ATENCIONCLIENTE@AOSOM.ES

TEL: 931294512

HECHO EN CHINA

FR

Si vous avez la moindre question, veuillez contacter notre centre d'assistance à la clientèle.

Nos coordonnées sont les suivantes:



0033-1-84166106



aosom@mhfrance.fr

Importé par:

MH France

2, rue Maurice Hartmann

92130 Issy-les-Moulineaux

France

Fabriqué en Chine

PT

Se tiver alguma dúvida, por favor contacte o nosso Centro de Atendimento ao Cliente.

Os nossos dados de contacto são os seguintes:



0034-931294512



atencioncliente@aosom.es

IMPORTADOR:

SPANISH AOSOM, S.L

C.ROC GROS N.15. 08550. ELS HOSTALET DE BALENYÀ

TEL: 931294512 (SEG-SEX DAS 7:30H ÀS 16:30H)

INFO@AOSOM.PT

WWW.AOSOM.PT

DE

Wenn Sie Fragen haben, wenden Sie sich bitte an unser Kundendienstzentrum.

Unsere Kontaktdaten stehen unten:



0049-0(40)-88307530



service@aosom.de

ADRESSE DES IMPORTEUR:

MH Handel GmbH

Wendenstraße 309

D-20537 Hamburg

Germany

IN CHINA HERGESTELLT

IT

In caso di dubbio, si prega di contattare il nostro centro assistenza clienti.

I nostri dettagli di contatto sono di seguito:



0039-0249471447



clienti@aosom.it

IMPORTATO DA:

AOSOM Italy srl

Centro Direzionale Milanofiori

Strada 1 Palazzo F1

20057 Assago (MI)

P.I.: 08567220960

FATTO IN CINA

