

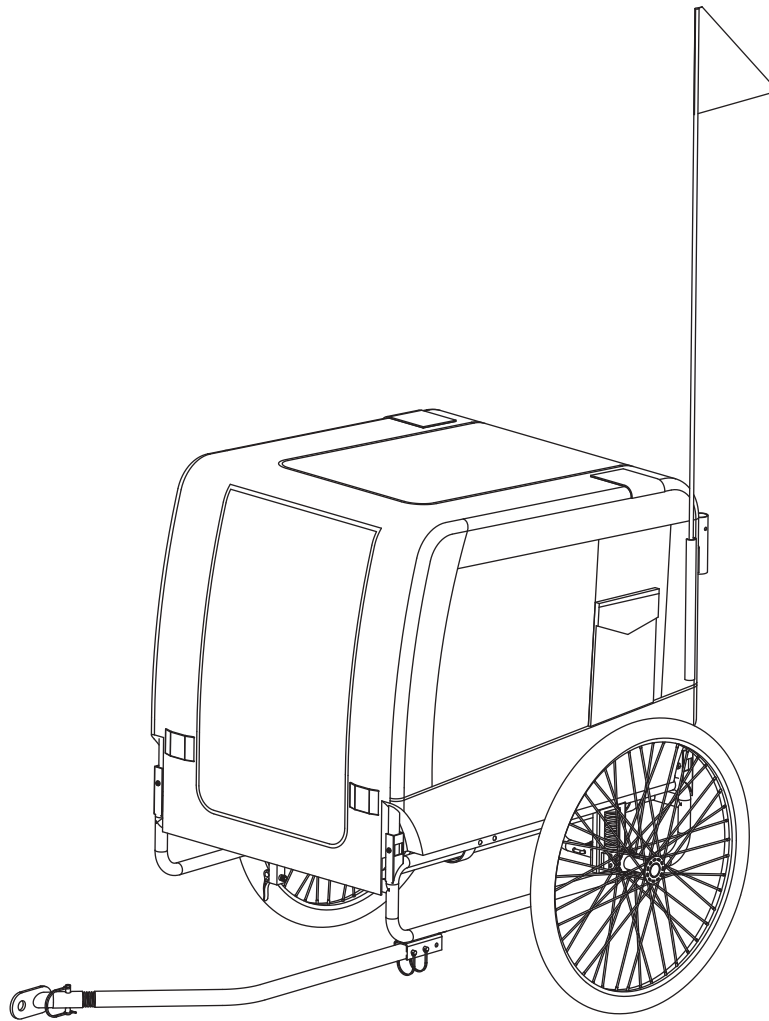

Aosom

IN221100596V01_US_CA

D00-170V00



EN_IMPORTANT, RETAIN FOR FUTURE REFERENCE: READ CAREFULLY.

FR_IMPORTANT: A LIRE ATTENTIVEMENT ET À CONSERVER POUR CONSULTATION ULTÉRIEURE.

ES_IMPORTANTE, LEA Y GUARDE PARA FUTURAS REFERENCIAS.

PT_IMPORTANTE, RETER PARA REFERÊNCIA FUTURA: LEIA ATENTAMENTE.

DE_WICHTIG! SORGFÄLTIG LESEN UND FÜR SPÄTER NACHSCHLAGEN AUFBEWAHREN.

IT_IMPORTANTE! CONSERVARE IL PRESENTE MANUALE PER FUTURO RIFERIMENTO E LEGGERLO ATTENTAMENTE.

EN

Dear customer,

Thank you for purchasing this product. So that your appliance serves you well, please read all the instructions in this user's manual. If you have any questions, please contact our customer care center, Our contact details are below:

FR

Cher client,

Nous vous remercions d'avoir acheté ce produit. Afin que vous puissiez profiter pleinement de votre appareil, veuillez lire toutes les instructions de ce manuel d'utilisation. Si vous avez la moindre question, veuillez contacter notre centre d'assistance à la clientèle, Nos coordonnées sont les suivantes:

DE

Sehr geehrter Kunde,

Vielen Dank, dass Sie dieses Produkt erworben haben. Damit Ihr Gerät Ihnen gute Dienste leistet, lesen Sie bitte alle Hinweise in diesem Benutzerhandbuch. Wenn Sie Fragen haben, wenden Sie sich bitte an unser Kundendienstzentrum, Unsere Kontaktdaten stehen unten:

ES

Queridos clientes,

Gracias por comprar este producto. Para que su electrodoméstico le sirva mejor, lea todas las instrucciones de este manual del usuario. Si tiene alguna pregunta, comuníquese con nuestro Centro de Atención al Cliente, Nuestros datos de contacto son los siguientes:

PT

Caros clientes,

Obrigado por adquirir este produto. Para que o seu aparelho o sirva melhor, leia todas as instruções deste manual do utilizador. Se tiver alguma dúvida, por favor contacte o nosso Centro de Atendimento ao Cliente, Os nossos dados de contacto são os seguintes:

IT

Caro Cliente,

Grazie per aver acquistato questo prodotto. Per servirti meglio con questo apparecchio ti prego di leggere tutte le istruzioni in presente manuale utente. In caso di dubbio, si prega di contattare il nostro centro assistenza clienti, I nostri dettagli di contatto sono di seguito:

Country	 Phone	 Email
US	001-877-644-9366	customerservice@aosom.com
CA	416-792-6088	customerservice@aosom.ca
UK	0044-800-240-4004	enquiries@mhstar.co.uk
DE	0049-0(40)-88307530	service@aosom.de
FR	0033-1-84166106	aosom@mhfrance.fr
ES&PT	0034-931294512	atencioncliente@aosom.es
IT	0039-0249471447	clienti@aosom.it

EN

1. Do not modify the trailer.
2. Always check all parts of the trailer are secure, tight and properly connected.
3. Do not lift the trailer up when the pet is inside.
4. Do not exceed 16Km/H (10MPH) maximum speed
5. Never use the trailer on uneven ground.
6. Never park the trailer near dangerous and busy roads.
7. The rider must wear an approved safety helmet.
8. Check the air pressure before every trip.
9. Be careful whilst riding in traffic, especially when turning corners and riding up and down slopes.
10. Do not store or use this trailer in areas exposed to high or low temperatures or humidity for prolonged periods.

FR

1. Ne modifiez pas techniquement la remorque.
2. Vérifiez toujours que toutes les parties de la remorque sont bien connectées correctement.
3. Ne soulevez pas la remorque lorsque l'animal est à l'état.
4. Ne pas excéder la vitesse maximale de 16Km/H (10MPH)
5. N'utilisez jamais la remorque sur un terrain inégal.
6. Ne garez jamais la remorque près d'une route dangereuse.
7. Le conducteur doit porter des casques de sécurité homologués.
8. Vérifiez la pression d'air avant chaque voyage.
9. Soyez prudent tout en conduisant dans la circulation en particulier les virages et les pentes.
10. Ne stockez pas ou utilisez cette remorque dans les zones exposées à des températures ou à une humidité élevées ou basses pendant une longue période.

ES

1. No modifique el remolque técnicamente.
2. Siempre inspeccione que todas las partes del remolque estén conectadas de manera correcta y firme.
3. No levante el remolque cuando la mascota esté adentro.
4. No exceda la velocidad máxima de los 16 km / H (10 MPH) al conducir
5. Nunca utilice el remolque en un lugar irregular.
6. Nunca estacione el remolque cerca de una carretera peligrosa.
7. El ciclista debe usar cascos de seguridad aprobados.
8. Compruebe la presión del aire antes de cada viaje.
9. Tenga cuidado al circular por el tráfico, especialmente en curvas y pendientes.
10. No almacene ni utilice el remolque en áreas expuestas a altas o bajas temperaturas o húmedas durante largo tiempo.

DE

1. Nehmen Sie keine technischen Änderungen am Anhänger vor.
2. Überprüfen Sie immer, ob alle Teile des Anhängers richtig angeschlossen und befestigt sind.
3. Heben Sie den Anhänger nicht an, wenn sich das Haustier darin befindet.
4. Überschreiten Sie nicht die Höchstgeschwindigkeit von 16 km/h (10 mph)
5. Nutzen Sie den Anhänger niemals an unebenen Stellen.
6. Parken Sie den Anhänger niemals in der Nähe einer gefährlichen Straße.
7. Der Fahrer sollte zugelassene Schutzhelme tragen.
8. Überprüfen Sie den Luftdruck vor jeder Fahrt.
9. Seien Sie vorsichtig, wenn Sie im Verkehr fahren, insbesondere in Kurven und in der Steigung.
10. Lagern oder verwenden Sie diesen Anhänger nicht in Bereichen, die längere Zeit hohen oder niedrigen Temperatur oder Luftfeuchtigkeit ausgesetzt sind.

IT

1. Non modificare il rimorchio tecnicamente.
2. Controllare sempre che tutte le parti del rimorchio siano connesse correttamente e strette in sicurezza.
3. Non sollevare il rimorchio quando l'animale si trova al suo interno.
4. Non superare la velocità massima di 16Km/H (10MPH)
5. Non utilizzare mai il rimorchio su un terreno irregolare.
6. Non parcheggiare mai il rimorchio vicino a strade pericolose.
7. L'utente alla guida deve indossare un elmetto di sicurezza omologato.
8. Controllare la pressione dell'aria prima di ogni uscita.
9. Fare attenzione se si guida nel traffico, in particolare in caso di curve pericolose e pendii.
10. Non conservare o utilizzare questo rimorchio a lungo in aree soggette a temperature particolarmente alte o basse, o in caso di umidità.

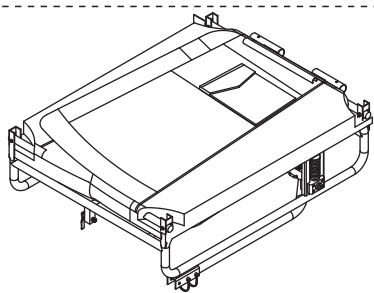

A x 1

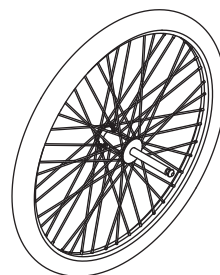

B x 2

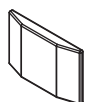

Whitex2
Redx2

C x 4

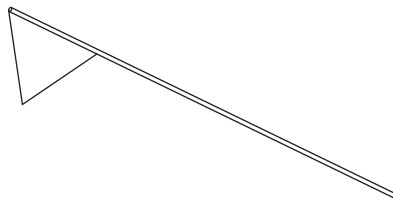

D x 1

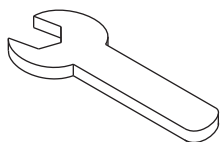

E x 1

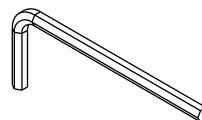

F x 1

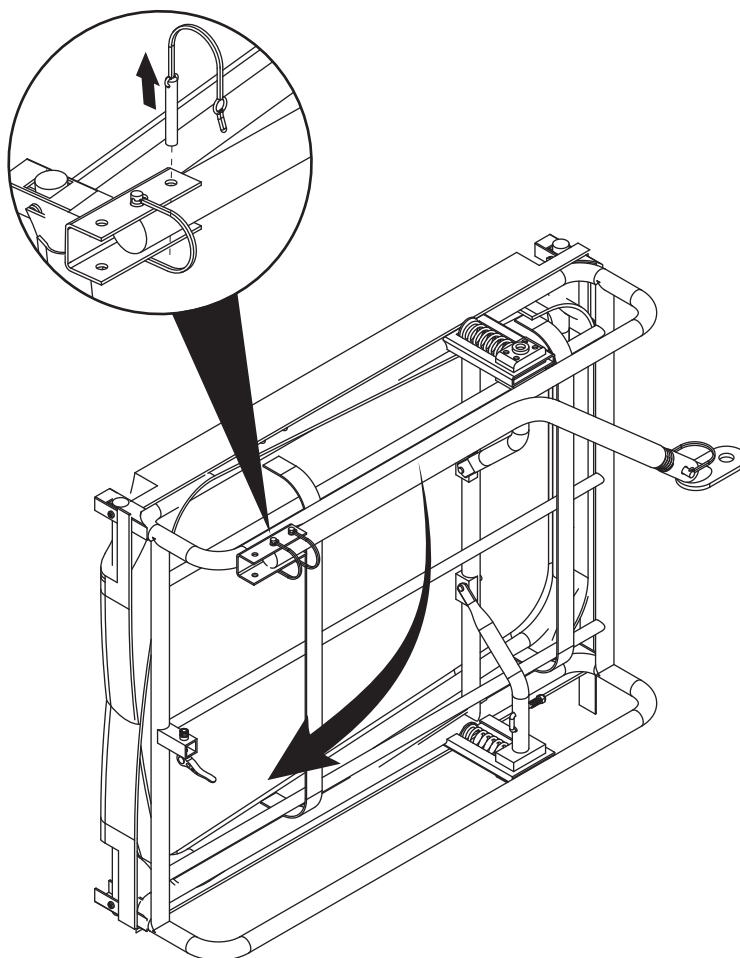

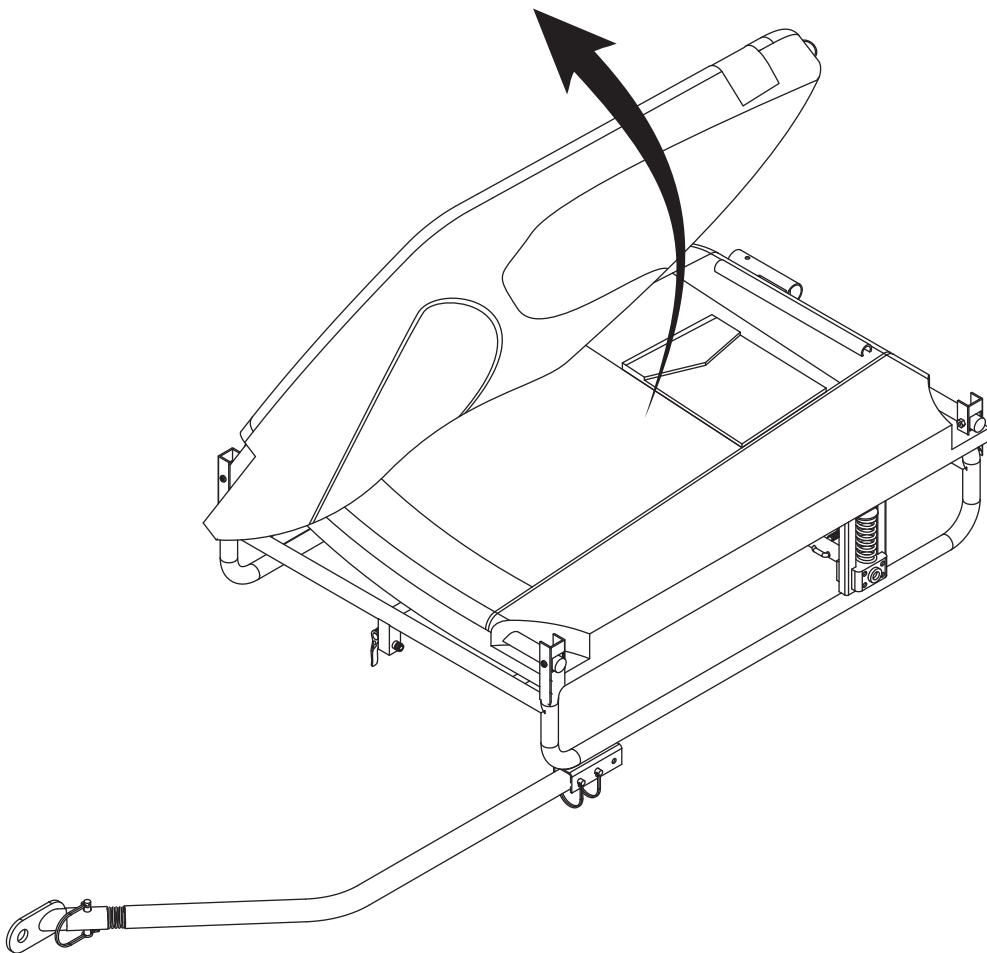
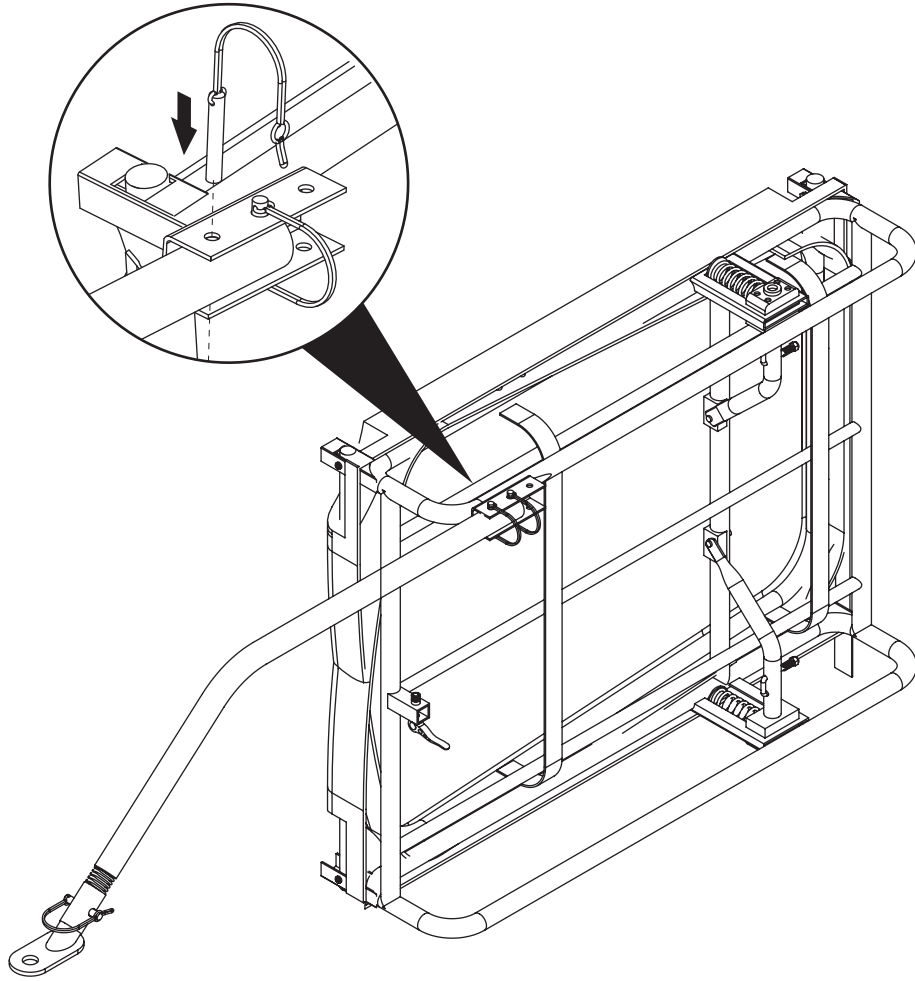

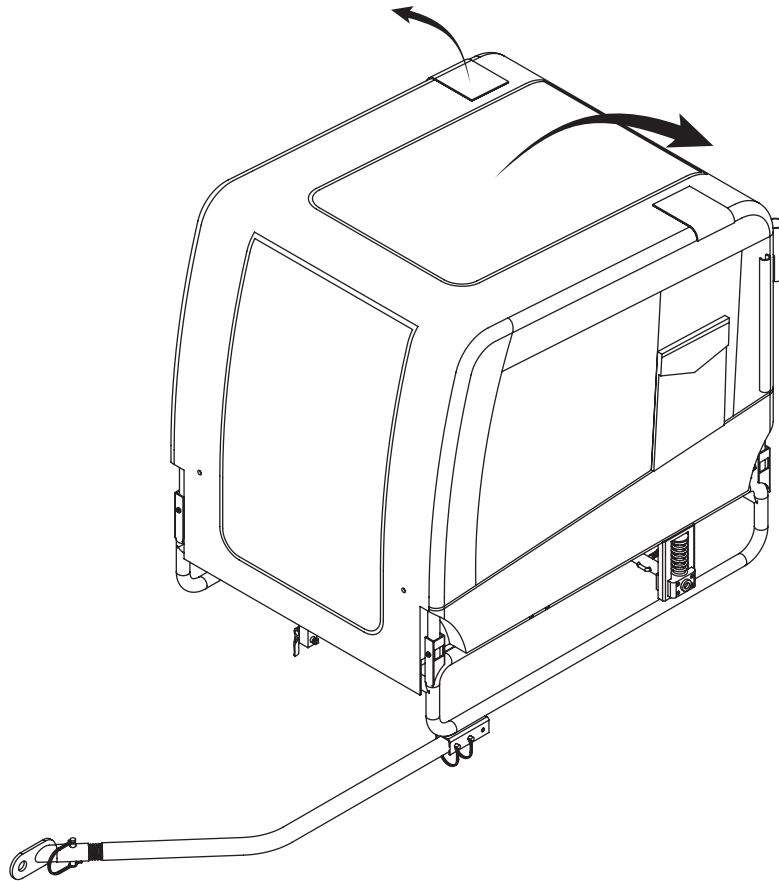
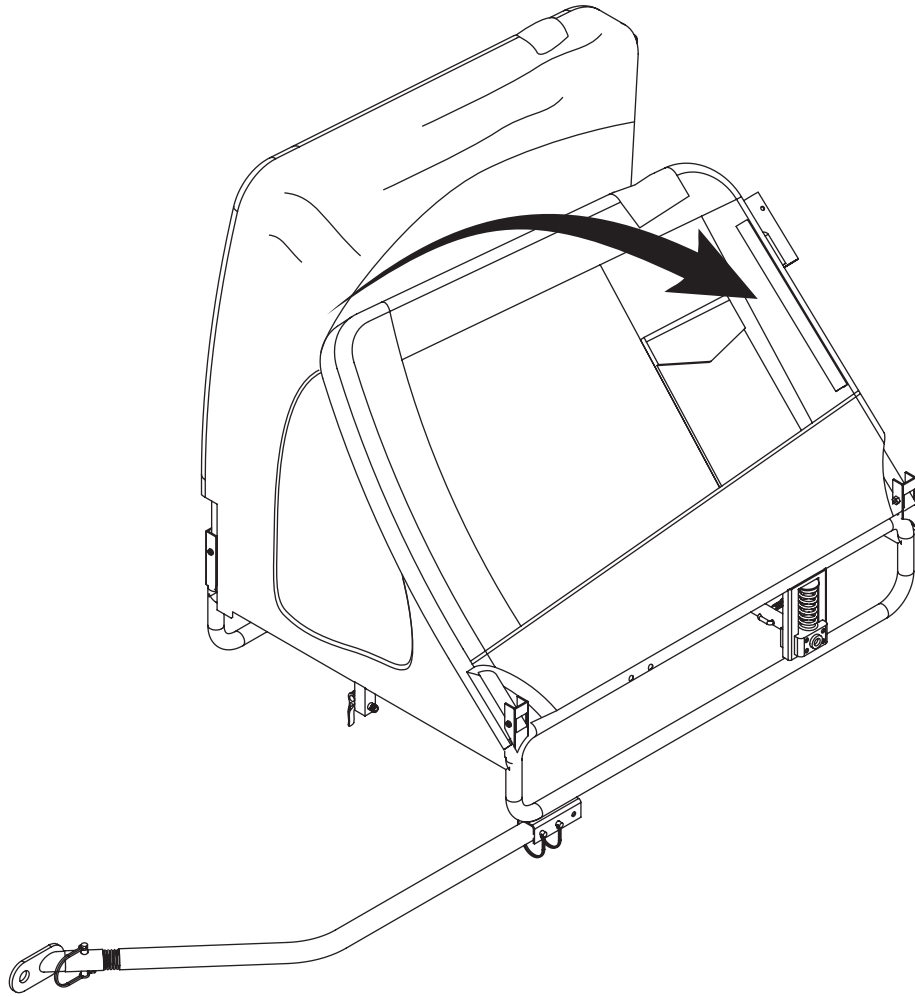

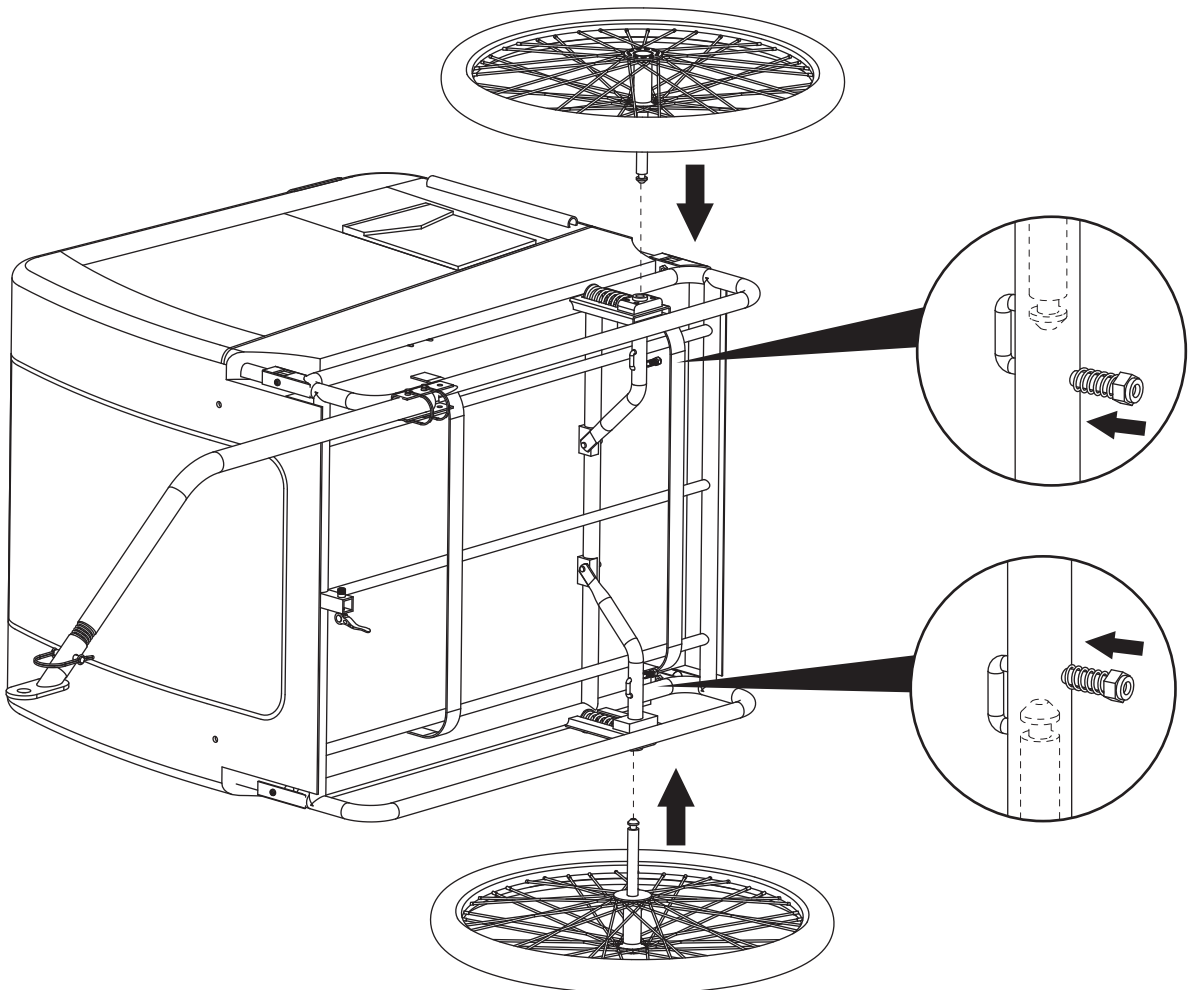
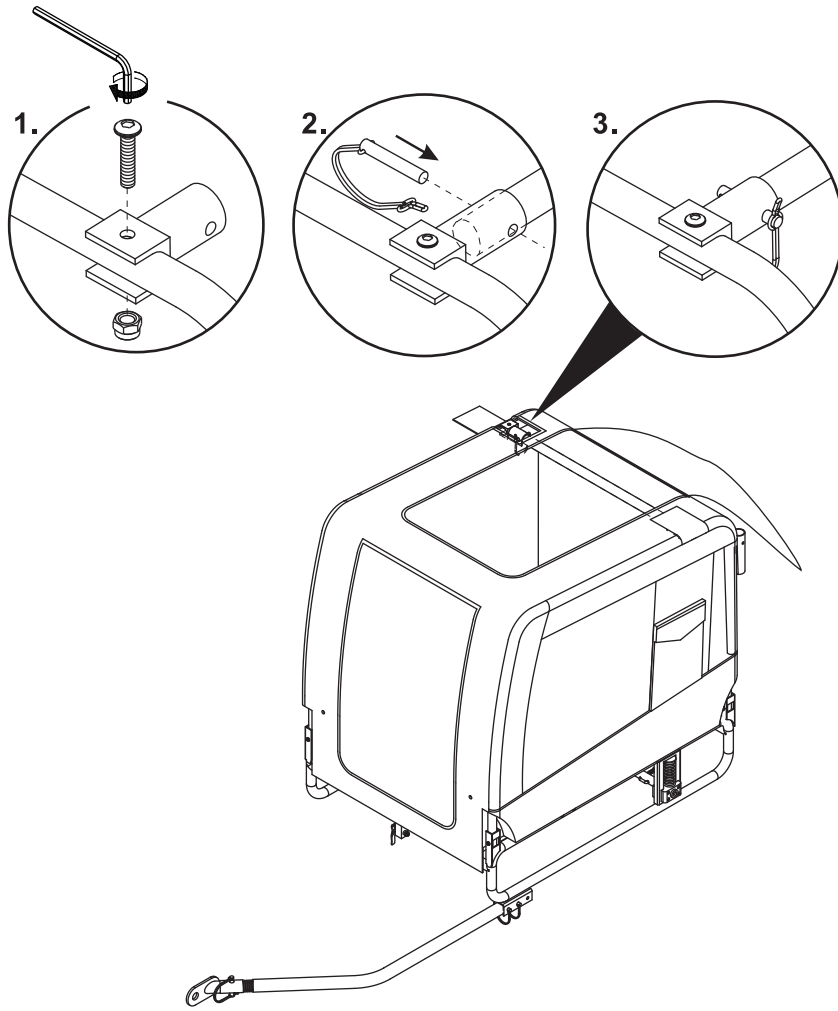

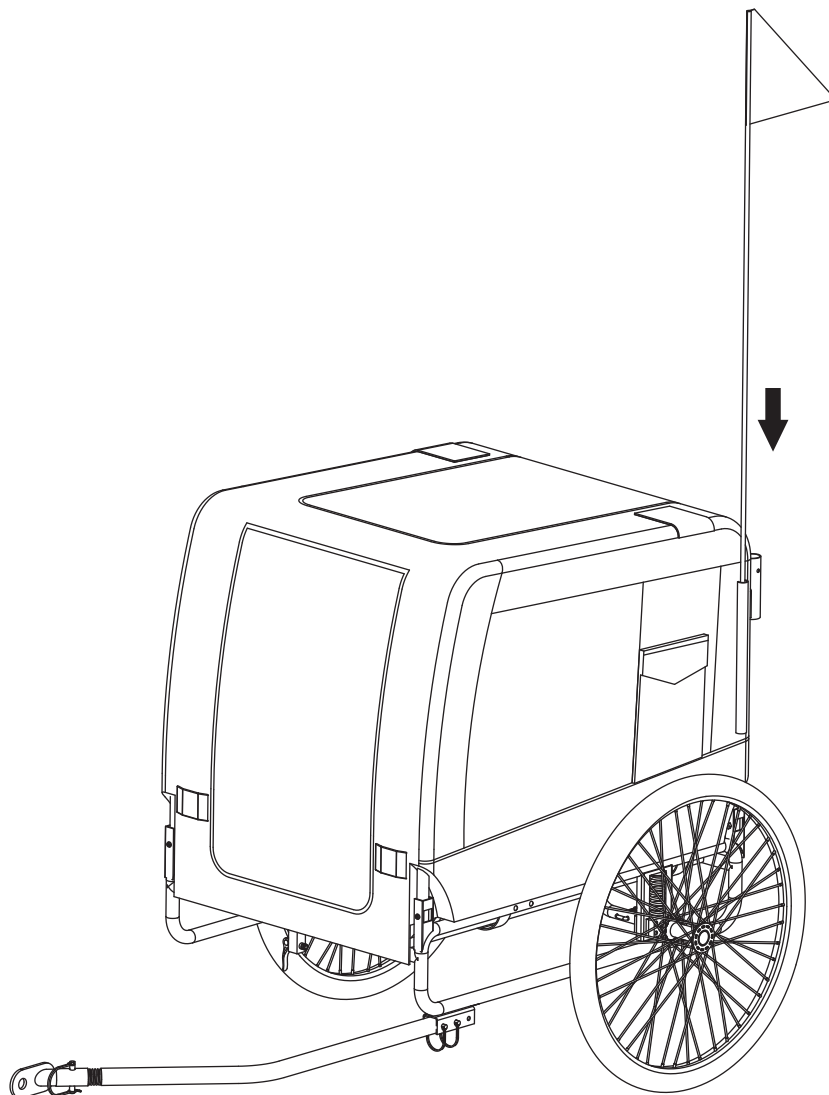
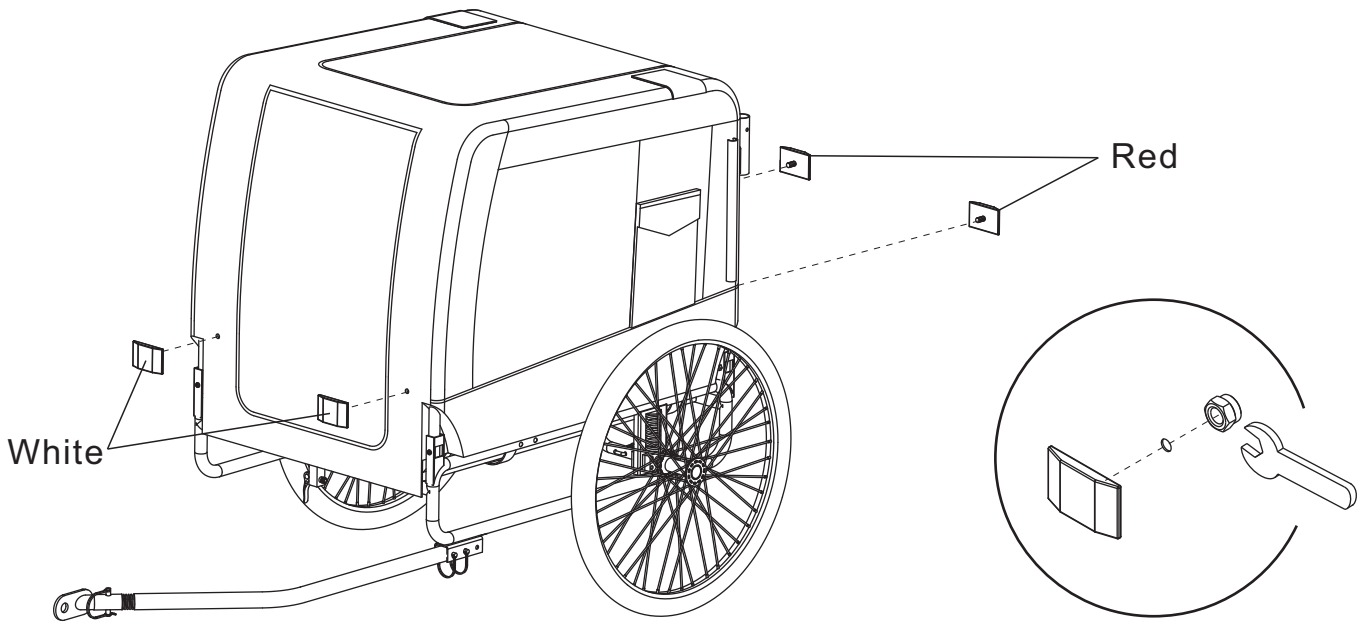

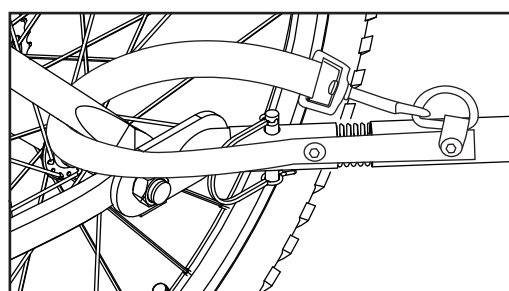
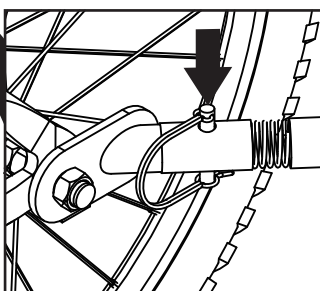
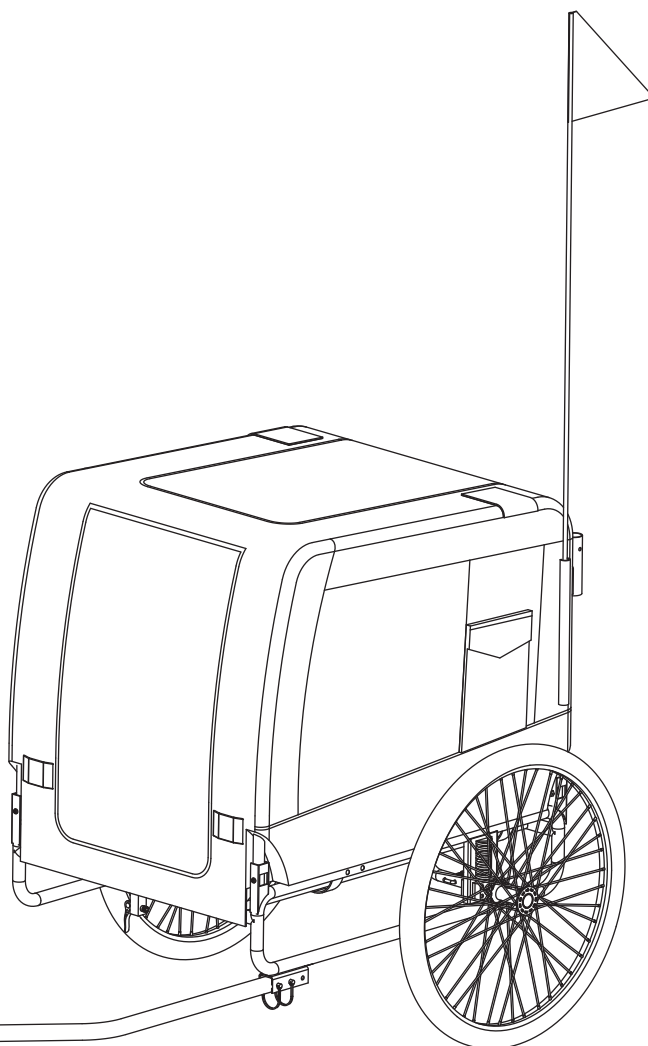
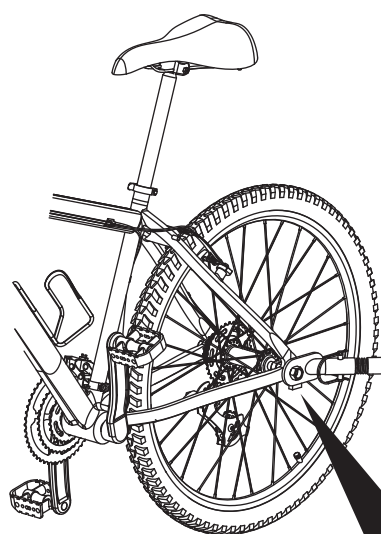
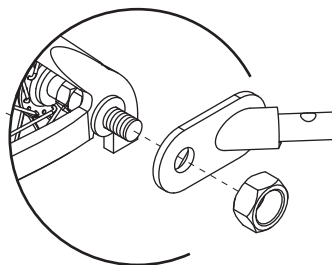
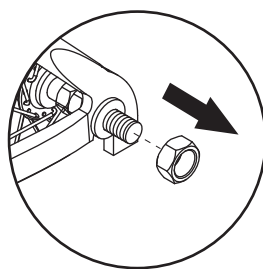
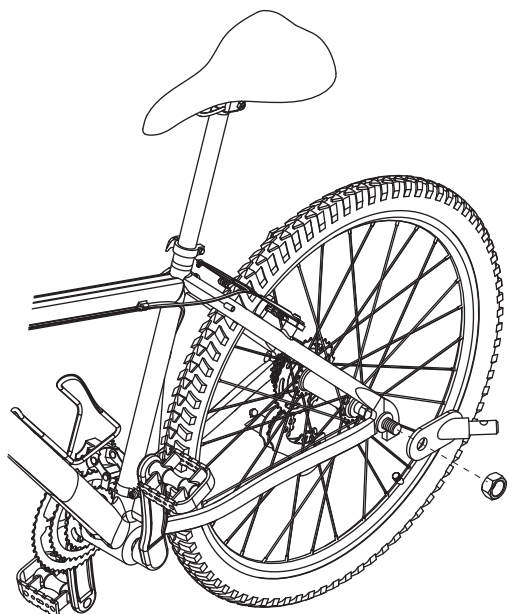

US

Imported by Aosom LLC
27150 SW Kinsman Rd Wilsonville, OR 97070 USA
MADE IN CHINA

CA

Imported by Aosom Canada Inc.
1251 Tapscott Road, Unit 101, Scarborough, Ontario Canada M1X 1S9
MADE IN CHINA

Importé par Aosom Canada Inc.
1251 Rue Tapscott, Unité 101, Scarborough, Ontario Canada M1X 1S9
FABRIQUÉ EN CHINE

UK

IMPORTER ADDRESS:
MH STAR UK LTD
Unit 27, Perivale Park,
Horsenden lane South
Perivale, UB6 7RH
MADE IN CHINA

FR

ADRESSE D'IMPORTATION:
MH FRANCE
2 Rue Maurice Hartmann
92130 Issy Les Moulineaux
France
FABRIQUÉ EN CHINE

ES

IMPORTADOR:
SPANISH AOSOM, S.L.
C/ROC GROS,Nº15.08550, ELS HOSTALETS DE BALENYÀ, SPAIN.
B66295775
WWW.AOSOM.ES
ATENCIONCLIENTE@AOSOM.ES
TEL: 931294512
HECHO EN CHINA

DE

ADRESSE DES IMPORTEURS:
MH Handel GmbH
Wendenstraße 309
D-20537 Hamburg
Germany
IN CHINA HERGESTELLT

IT

IMPORTATO DA:
AOSOM Italy srl
Centro Direzionale Milanofiori
Strada 1 Palazzo F1
20057 Assago (MI)
P.I.: 08567220960
FATTO IN CINA