



IN221100813V02_GL

B30-029V00



EN_ IMPORTANT, RETAIN FOR FUTURE REFERENCE: READ CAREFULLY.

**FR_ IMPORTANT: A LIRE ATTENTIVEMENT ET À CONSERVER POUR CONSULTATION
ULTÉRIEURE.**

ES_ IMPORTANTE, LEA Y GUARDE PARA FUTURAS REFERENCIAS.

PT_ IMPORTANTE, REter PARA REFERÊNCIA FUTURA: LEIA ATENTAMENTE.

DE_ WICHTIG! SORGFÄLTIG LESEN UND FÜR SPÄTER NACHSCHLAGEN AUFBEWAHREN.

**IT_ IMPORTANTE! CONSERVARE IL PRESENTE MANUALE PER FUTURO RIFERIMENTO E
LEggerlo ATTENTAMENTE.**

EN

Dear customer,

Thank you for purchasing this product. So that your appliance serves you well, please read all the instructions in this user's manual. If you have any questions, please contact our customer care center, Our contact details are below:

FR

Cher client,

Nous vous remercions d'avoir acheté ce produit. Afin que vous puissiez profiter pleinement de votre appareil, veuillez lire toutes les instructions de ce manuel d'utilisation. Si vous avez la moindre question, veuillez contacter notre centre d'assistance à la clientèle, Nos coordonnées sont les suivantes:

DE

Sehr geehrter Kunde,

Vielen Dank, dass Sie dieses Produkt erworben haben. Damit Ihr Gerät Ihnen gute Dienste leistet, lesen Sie bitte alle Hinweise in diesem Benutzerhandbuch. Wenn Sie Fragen haben, wenden Sie sich bitte an unser Kundendienstzentrum, Unsere Kontaktdaten stehen unten:

ES

Queridos clientes,

Gracias por comprar este producto. Para que su electrodoméstico le sirva mejor, lea todas las instrucciones de este manual del usuario. Si tiene alguna pregunta, comuníquese con nuestro Centro de Atención al Cliente, Nuestros datos de contacto son los siguientes:

PT

Caros clientes,

Obrigado por adquirir este produto. Para que o seu aparelho o sirva melhor, leia todas as instruções deste manual do utilizador. Se tiver alguma dúvida, por favor contacte o nosso Centro de Atendimento ao Cliente, Os nossos dados de contacto são os seguintes:

IT

Caro Cliente,

Grazie per aver acquistato questo prodotto. Per servirti meglio con questo apparecchio ti prego di leggere tutte le istruzioni in presente manuale utente. In caso di dubbio, si prega di contattare il nostro centro assistenza clienti, I nostri dettagli di contatto sono di seguito:

Country	 Phone	 Email
US	001-877-644-9366	customerservice@aosom.com
CA	416-792-6088	customerservice@aosom.ca
UK	0044-800-240-4004	enquiries@mhstar.co.uk
DE	0049-0(40)-88307530	service@aosom.de
FR	0033-1-84166106	aosom@mhfrance.fr
ES	0034-931294512	atencioncliente@aosom.es
PT	0034-931294512	info@aosom.pt
IT	0039-0249471447	clienti@aosom.it

Installation

1. Select the place that the lamp can reach the sunshine , out off shadow.
 2. Drill three holes on the suitable place.
- Fix the mounted base by supplied Nut & Bol.
- Connect the two biggest pipe, fix it to the mounted base by supplied screws.
- Connect other two pipes.
- Place lamp on the head pipe as below picture.

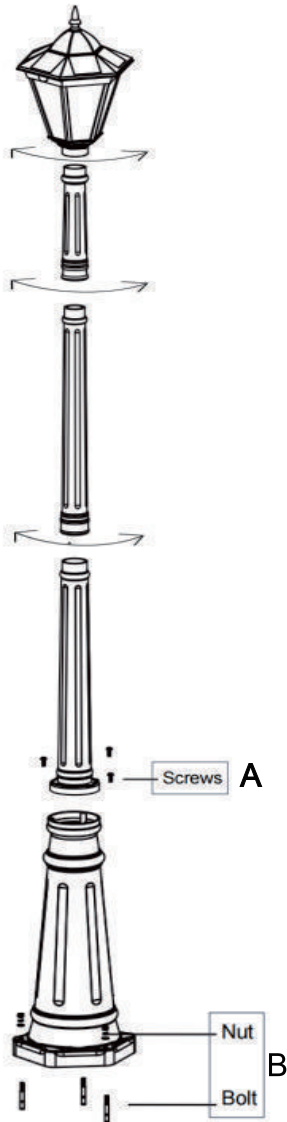



Operation

1. Please let the lamp head reach the sunshine about 1-2 days for the first time using to activate battery.
 2. Switch the button to P or ON.
 P: PIR sensor activated model. It will be low bright without person. will be high bright while person passing.
 ON: always high bright.
 3. Automatically turn on at dusk and off dawn.
- Remark: There's light control sensor on the cap, it will not light up when other light sources cover the cap.

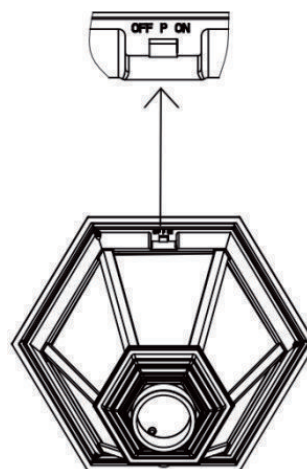
Note: Solar panels are not to be used until they have been exposed to the sun!



HARDWARE

<p>A x3</p>  <p>TM6*15</p>	<p>B x3</p>  <p>D10*100</p>
--	---



Installation

1. Choisissez l'endroit où la lampe peut atteindre le soleil, hors de l'ombre.

2. Percez trois trous à l'endroit approprié. Fixez la base montée avec l'écrou et le boulon fournis. Connectez les deux plus gros tuyaux, fixez-les à la base montée avec les vis fournies. Connectez les deux autres tuyaux. Placez la lampe sur le tuyau de tête comme sur l'image ci-dessous.

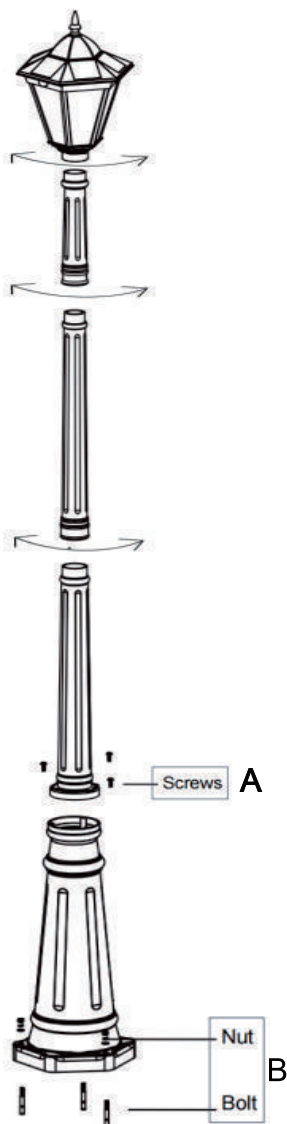

Fonctionnement

1. Veuillez laisser la tête de la lampe atteindre le soleil pendant 1-2 jours lors de la première utilisation pour activer la batterie.

2. Placez le bouton sur P ou ON. P : modèle avec capteur PIR activé. Elle sera faiblement lumineuse sans personne. Elle sera fortement lumineuse au passage d'une personne. ON : toujours très lumineux.

3. S'allume automatiquement au crépuscule et s'éteint à l'aube. Remarque : Il y a un capteur de contrôle de la lumière sur le capuchon, il ne s'allumera pas si d'autres sources de lumière couvrent le capuchon. Traduit avec

Remarque : les panneaux solaires ne doivent pas être utilisés avant d'avoir été exposés au soleil !

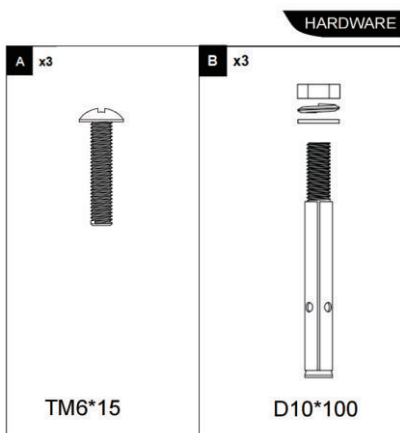
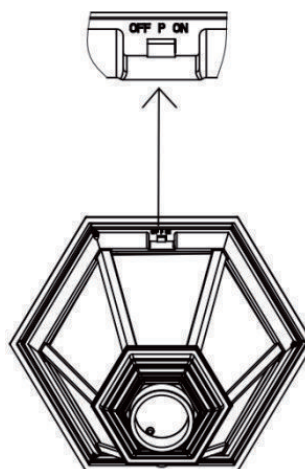

Instalación

1. Seleccione el lugar donde la lámpara pueda alcanzar la luz del sol , fuera de la sombra.
2. Taladre tres orificios en el lugar adecuado. Fije la base montada con las tuercas y tornillos suministrados. Conecte los dos tubos más grandes y fíjelos a la base con los tornillos suministrados. Conecte los otros dos tubos. Coloque la lámpara en el tubo principal como se muestra en la imagen.

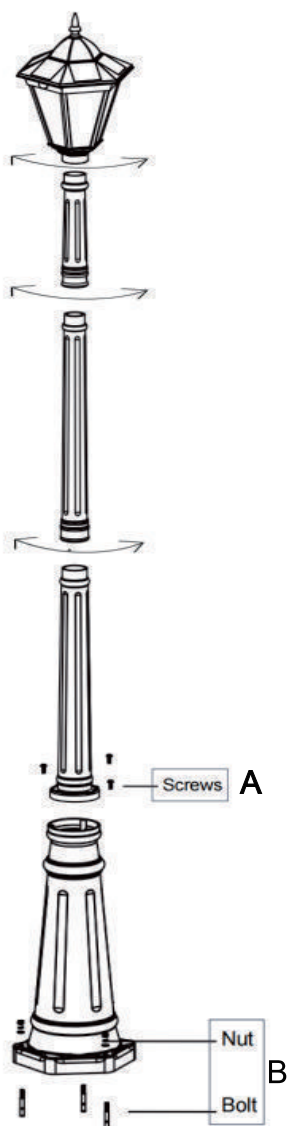



Funcionamiento

1. Por favor, deje que la cabeza de la lámpara llegue a la luz del sol alrededor de 1-2 días para la primera vez que se utiliza para activar la batería.
2. Cambie el botón a P u ON. P: Modelo activado por sensor PIR. Será de bajo brillo sin persona. será de alto brillo, mientras que la persona que pasa. ON: siempre alto brillante.
3. Encendido automático al anochecer y apagado al amanecer. Nota: Hay sensor de control de luz en la tapa, no se encenderá cuando otras fuentes de luz cubren la tapa.

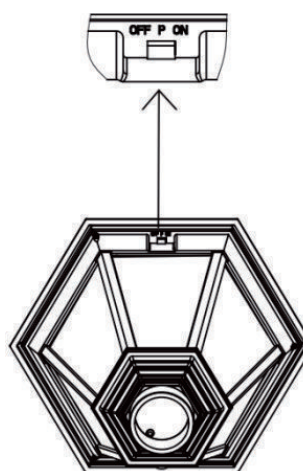
Nota: Los paneles solares no deben utilizarse hasta que hayan estado expuestos al sol.



HARDWARE

<p>A x3</p>  <p>TM6*15</p>	<p>B x3</p>  <p>D10*100</p>
--	---



Instalação

1. Seleccionar o local onde a lâmpada pode alcançar o sol, fora da sombra.
2. Fazer três furos no local adequado. Fixar a base montada através do Nut & Bol. Ligar os dois maiores tubos, fixá-los à base montada por parafusos fornecidos. Ligar outros dois canos. Colocar a lâmpada no tubo da cabeça, como na figura abaixo.

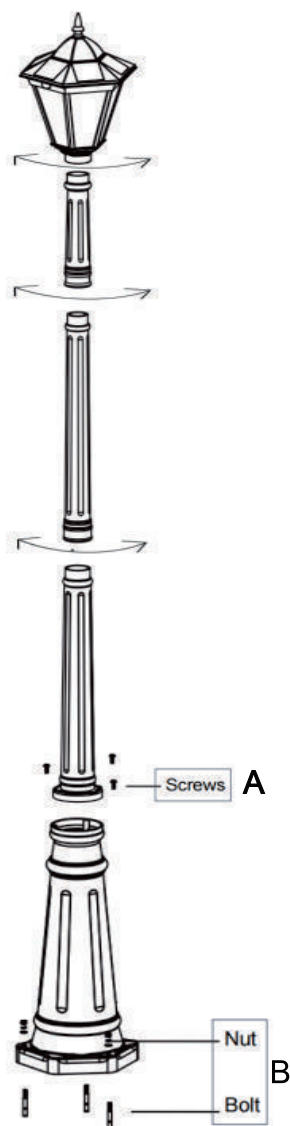

Operação

1. Deixar a cabeça da lâmpada alcançar o sol cerca de 1-2 dias pela primeira vez, utilizando para activar a bateria.
2. Mudar o botão para P ou ON. P: Modelo com sensor PIR activado. Será de baixo brilho sem pessoa. Será de alto brilho enquanto a pessoa passa. ON: sempre com alto brilho.
3. Ligar automaticamente ao anoitecer e desligar ao amanhecer. Observações: Há um sensor de controlo de luz na tampa, não acenderá quando outras fontes de luz cobrirem a tampa.

Nota: Os painéis solares só devem ser utilizados depois de terem sido expostos ao sol!

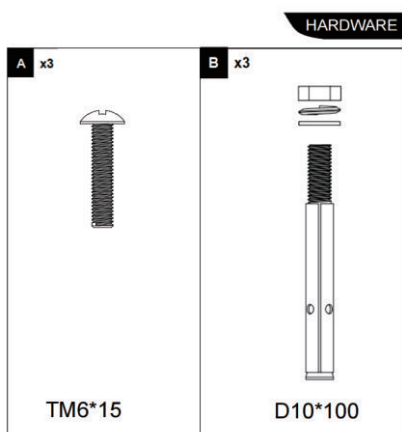
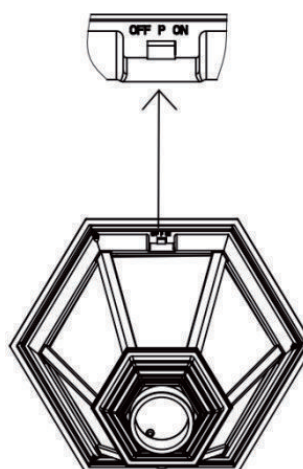

1. Wählen Sie den Ort, an dem die Lampe den Sonnenschein erreichen kann und nicht im Schatten steht.
2. Bohren Sie drei Löcher an der geeigneten Stelle.
Befestigen Sie den montierten Sockel mit der mitgelieferten Schraube und Mutter.
Verbinden Sie die beiden größten Rohre und befestigen Sie sie mit den mitgelieferten Schrauben am montierten Sockel.
Verbinden Sie die beiden anderen Rohre.
Setzen Sie die Lampe wie unten abgebildet auf das Hauptrohr.

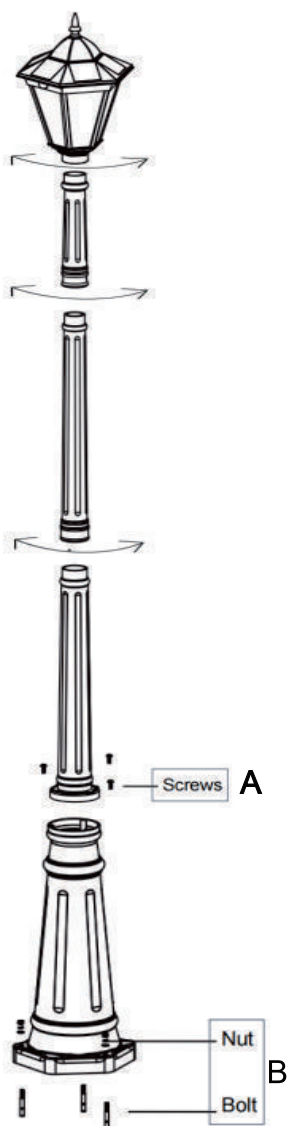

Bedienung

1. Bitte lassen Sie den Lampenkopf bei der ersten Benutzung etwa 1-2 Tage in der Sonne stehen, um den Akku zu aktivieren.
2. Schalten Sie die Taste auf P oder EIN.
P: Modell mit aktiviertem PIR-Sensor. Es wird schwach leuchten wenn keine Person vorbeigeht, und stark leuchten, wenn eine Person vorbeigeht.
EIN: immer stark leuchten.
3. Automatisches Einschalten bei Dämmerung und Ausschalten bei Sonnenaufgang.
Bemerkung: Es gibt einen Lichtkontrollsensor auf der Kappe, er leuchtet nicht, wenn andere Lichtquellen die Kappe verdecken.

Hinweis: Die Solarmodule dürfen erst verwendet werden, wenn sie der Sonne ausgesetzt waren!

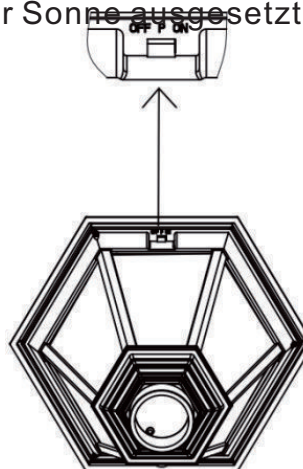
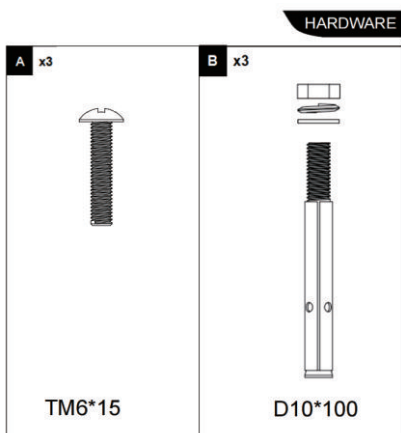

Installazione

1. Scegliere un luogo in cui la lampada possa raggiungere la luce del sole, al riparo dall'ombra.
2. Praticare tre fori nel punto adatto. Fissare la base montata con il dado e il bullone in dotazione. Collegare i due tubi più grandi e fissarli alla base montata con le viti in dotazione. Collegare gli altri due tubi. Posizionare la lampada sul tubo di testa come indicato nell'immagine sottostante.

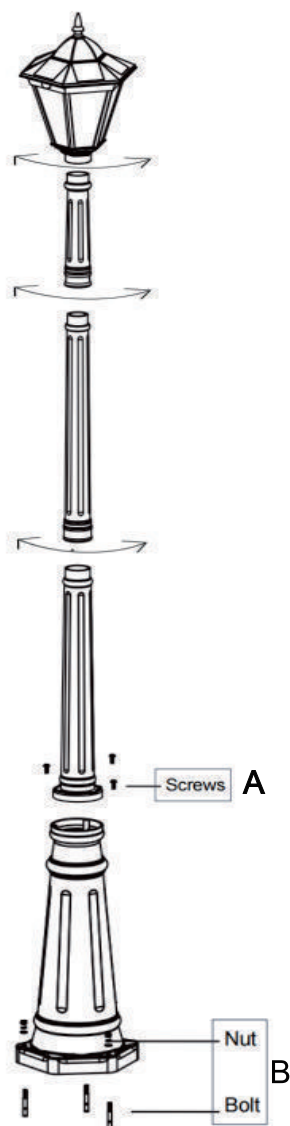

Funzionamento

1. Lasciare che la testa della lampada raggiunga la luce del sole per circa 1-2 giorni al primo utilizzo per attivare la batteria.
2. Posizionare il pulsante su P o ON. P: modello con sensore PIR attivato. Sarà poco luminosa in assenza di persone. Sarà molto luminosa al passaggio di una persona. ON: sempre alta luminosità.
3. Si accende automaticamente al crepuscolo e si spegne all'alba. Nota: Il sensore di controllo della luce è posto sulla calotta e non si accende quando altre fonti luminose coprono la calotta.

Nota: i pannelli solari non devono essere utilizzati prima di essere stati esposti al sole!

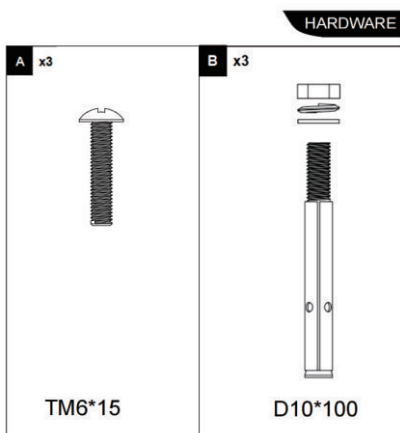
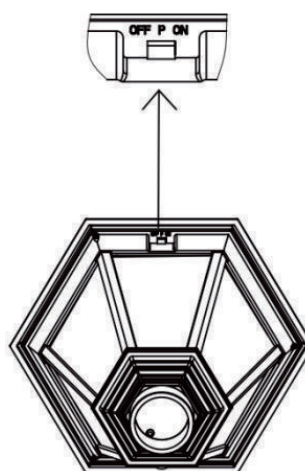

US

Imported by Aosom LLC
27150 SW Kinsman Rd Wilsonville, OR 97070 USA
MADE IN CHINA

CA

Imported by Aosom Canada Inc.
7270 Woodbine Avenue, Unit 307, Markham, Ontario Canada
L3R 4B9
MADE IN CHINA

Importé par Aosom Canada Inc.
7270 Woodbine Avenue, unité 307, Markham, Ontario Canada
L3R 4B9
Fabriqué en Chine

UK

IMPORTER ADDRESS:
MH STAR UK LTD
Unit 27, Perivale Park,
Horsenden lane South
Perivale, UB6 7RH
MADE IN CHINA

FR

ADRESSE D'IMPORTATION:
MH FRANCE
2 Rue Maurice Hartmann
92130 Issy Les Moulineaux
France
FABRIQUÉ EN CHINE

ES

IMPORTADOR:
SPANISH AOSOM, S.L.
C/ROC GROS, N°15.08550, ELS HOSTALET DE BALENYÀ, SPAIN.
B66295775
WWW.AOSOM.ES
ATENCIONCLIENTE@AOSOM.ES
TEL: 931294512
HECHO EN CHINA

PT

SPANISH AOSOM, S.L
C.ROC GROS N.15, 08550. ELS HOSTALET DE BALENYÀ
TEL: 931294512 (SEG-SEX DAS 7:30H ÀS 16:30H)
INFO@AOSOM.PT
WWW.AOSOM.PT

DE

ADRESSE DES IMPORTEURS:
MH Handel GmbH
Wendenstraße 309
D-20537 Hamburg
Germany
IN CHINA HERGESTELLT

IT

IMPORTATO DA:
AOSOM Italy srl
Centro Direzionale Milanofiori
Strada 1 Palazzo F1
20057 Assago (MI)
P.I.: 08567220960
FATTO IN CINA