

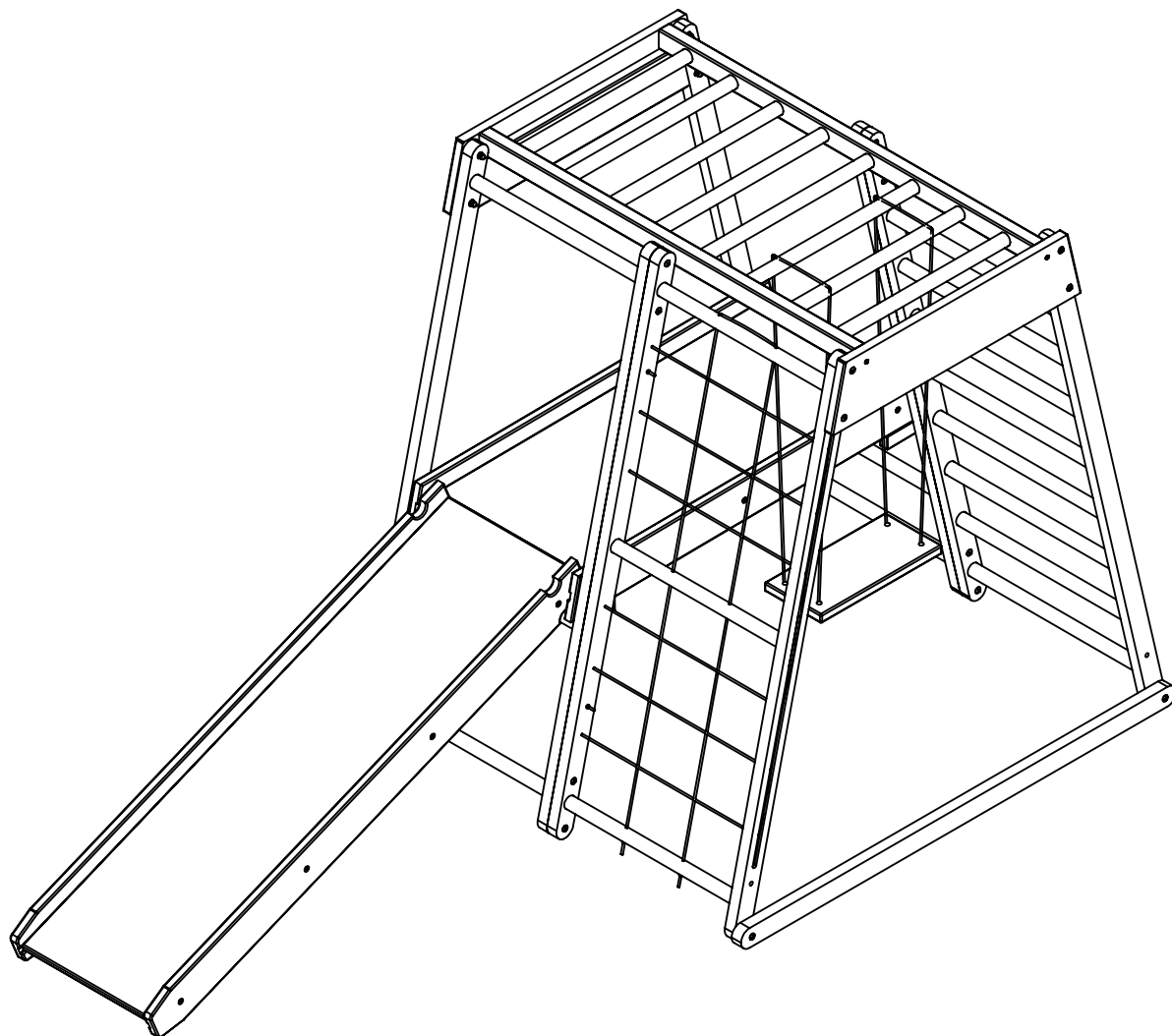

IN221200067V02_US_CA

331-024V00



FR: INSTRUCTIONS D'ASSEMBLAGE
EN: ASSEMBLY INSTRUCTION

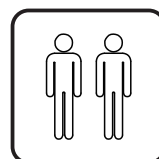
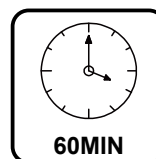



FR: IMPORTANT : A LIRE ATTENTIVEMENT ET À CONSERVER POUR CONSULTATION ULTÉRIEURE.
EN: IMPORTANT, RETAIN FOR FUTURE REFERENCE: READ CAREFULLY.

Dear customer,

Thank you for purchasing this product. So that your appliance serves you well, please read all the instructions in this user's manual. If you have any questions, please contact our customer care center.

Our contact details are below:

Country	 Phone	 Email
US	001-877-644-9366	customerservice@aosom.com
CA	416-792-6088	customerservice@aosom.ca

WARNING



These instructions are important to minimise chances of injury. Please read each of them thoroughly before you assemble and use this trampoline. Retain this manual for future reference.

1. Maximum weight of the user shall NOT exceed 45kg
2. This product is designed for children ages 2- 5 years, one child only use.
3. Do not allow children under 3 years old nearby during assembly. Small parts – choking hazard!
4. Domestic use only.
5. Sufficient placement space and flat ground
6. Use Children climber only with mature, knowledgeable supervision, not to be used by children alone

Cher client,

Nous vous remercions d'avoir acheté ce produit. Afin que vous puissiez profiter pleinement de votre appareil, veuillez lire toutes les instructions de ce manuel d'utilisation. Si vous avez la moindre question, veuillez contacter notre centre d'assistance à la clientèle.

Nos coordonnées sont les suivantes:

Country	 Phone	 Email
US	001-877-644-9366	customerservice@aosom.com
CA	416-792-6088	customerservice@aosom.ca

AVERTISSEMENT

Ces instructions sont importantes pour minimiser les risques de blessures. Veuillez les lire attentivement avant d'assembler et d'utiliser ce produit. Conservez ce manuel pour toute référence ultérieure.

1. Le poids maximum de l'utilisateur ne doit PAS dépasser 45 kg
2. Ce produit est conçu pour les enfants âgés de 2 à 5 ans, un seul enfant à utiliser.
3. Ne laissez pas les enfants de moins de 3 ans à proximité pendant l'assemblage. Petites pièces - risque d'étouffement !
4. Usage domestique uniquement.
5. Espace de placement suffisant et sol plat.
6. Utilisez le grimpeur pour enfants uniquement sous la supervision d'une personne apte et bien informée, ne pas utiliser par des enfants seuls.

PARTS

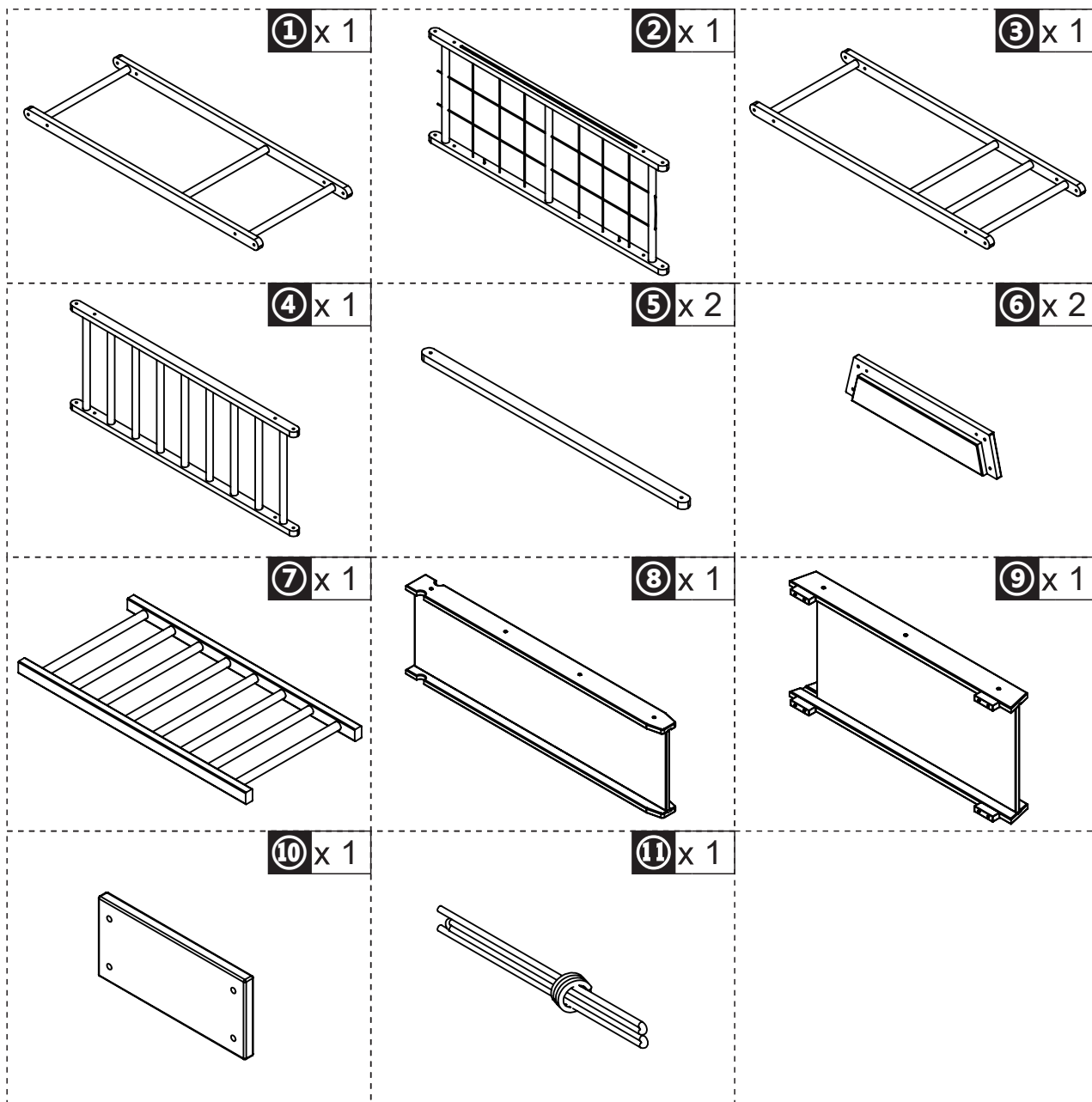

HARDWARE

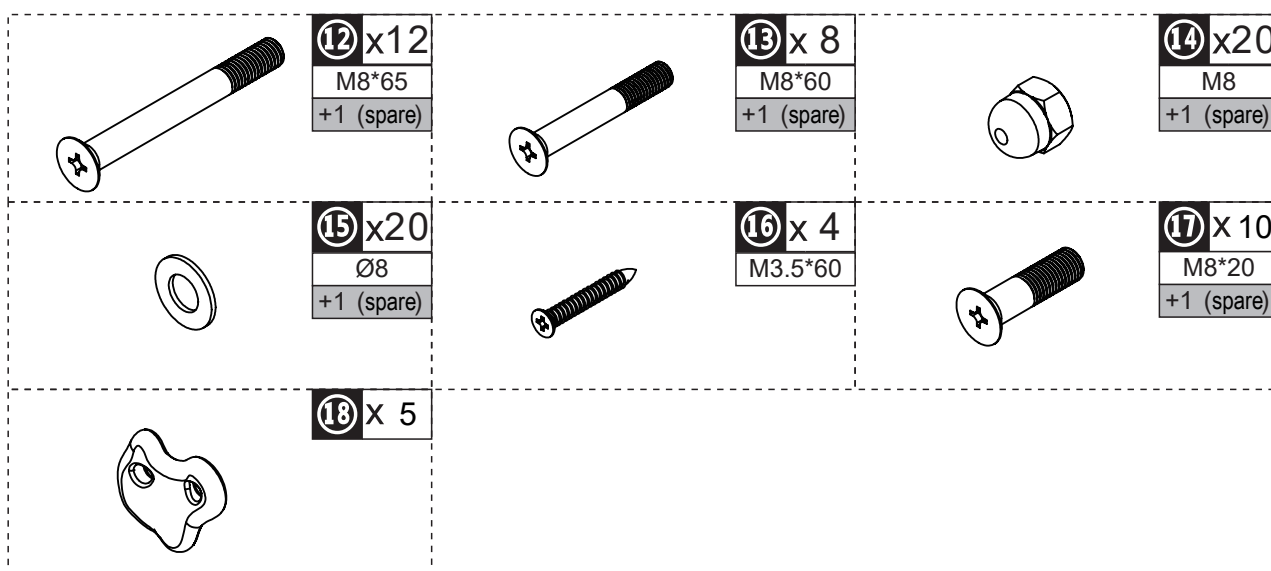

12 x 4
M8*65

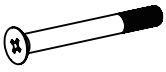

14 x 4
M8



15 x 4
Ø8

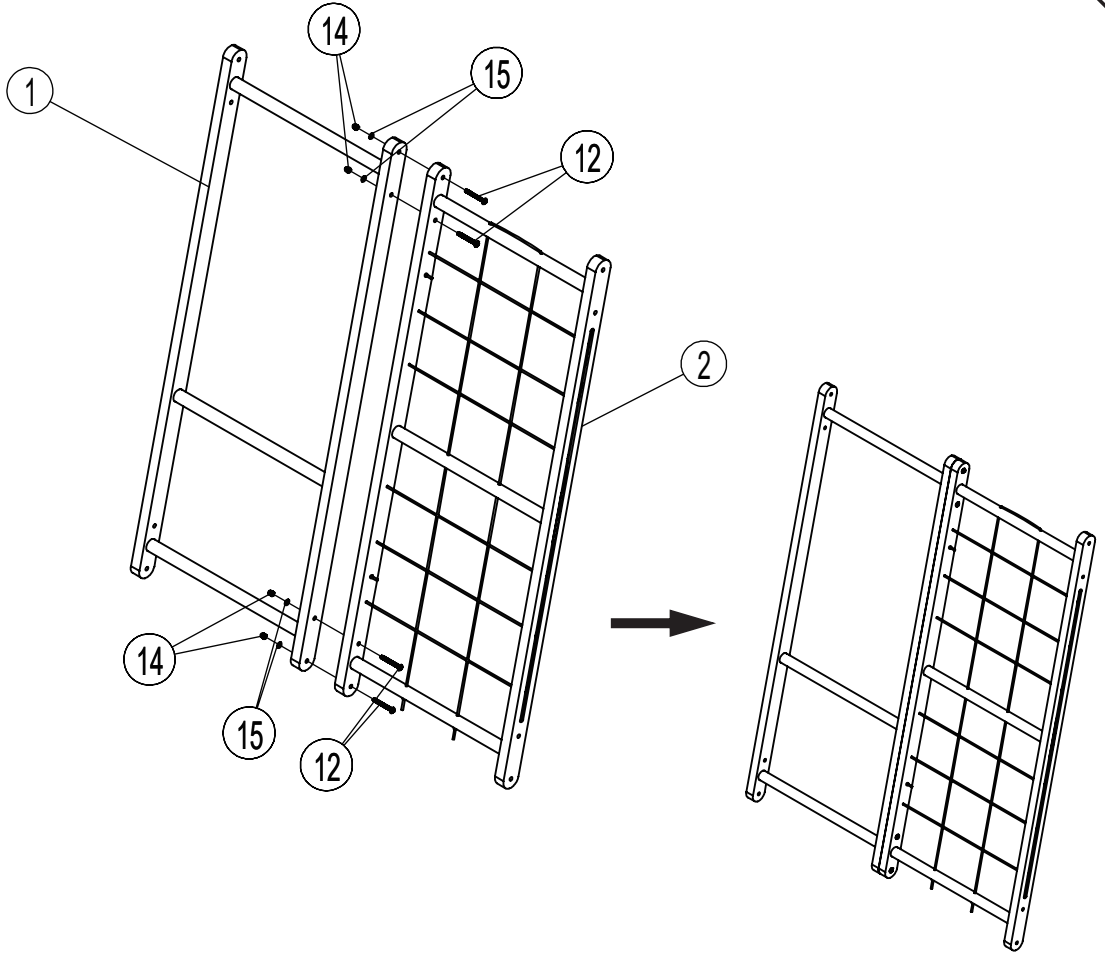

12 x 4
M8*65

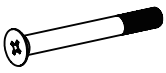

14 x 4
M8



15 x 4
Ø8

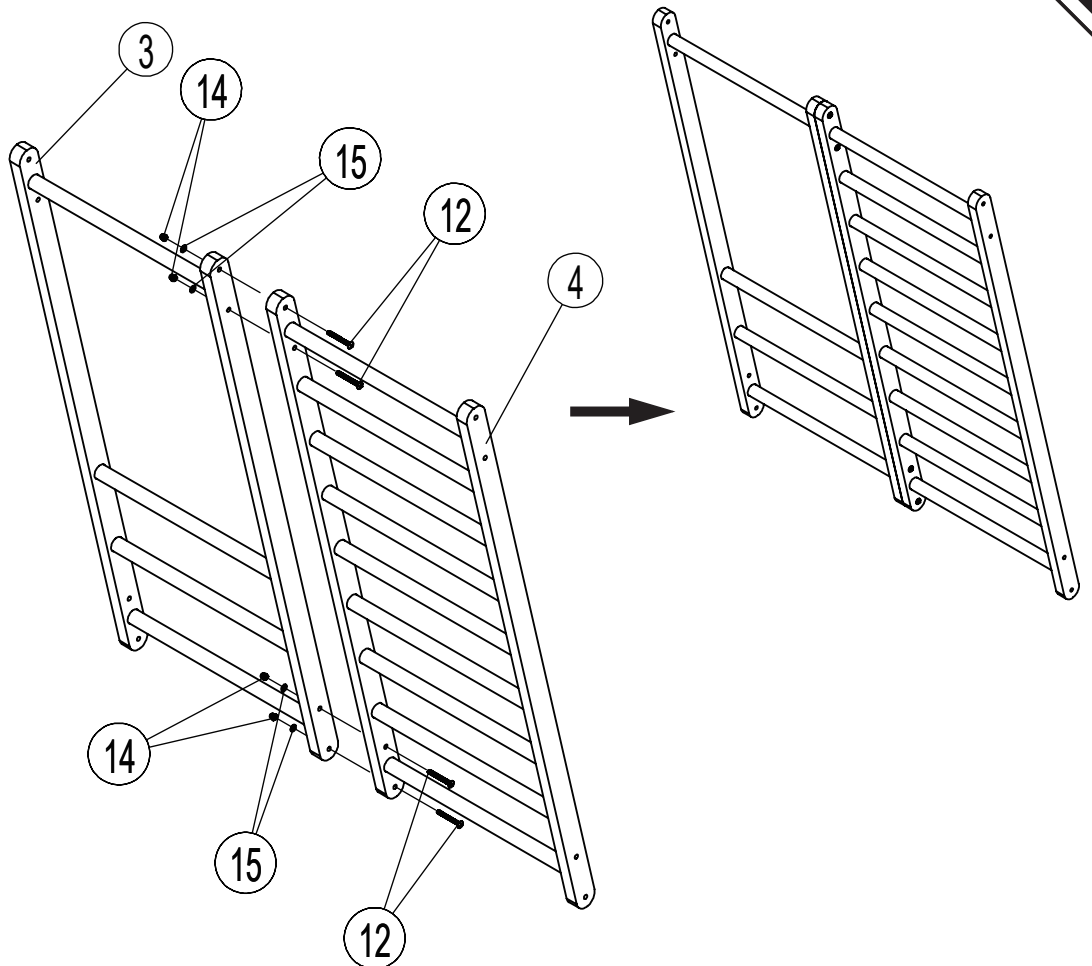

12 x 4
M8*65

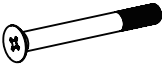

15 x 8
M8*60



14 x 12
M8



15 x 12
Ø8

