



CHILDREN ELECTRIC MOTORCYCLE MANUAL

- Suitable age 18-60 months.
- This product should be assembled by adult.
- This instruction contains important safety information content, please keep it as a reference.
- Music, light
- Forward and backward



IMPORTANT, RETAIN FOR FUTURE REFERENCE: READ CAREFULLY

ASSEMBLY INSTRUCTION

About the products





Thank you for choosing our children electric motorcycle. We always keep pursuing being outstanding and designing comfortable and safe ride on car for children.

Please read this instruction carefully before use, it will tell you the right way of assembling and operating. To avoid incorrect operations damaging the product or injuring your children. Please keep this instruction.

Specifications

Battery	6V 4AH
Main material	PP
Motor	RS-380-6V,RPM14000 x1
Suitable ages	18-60 months
Maximum weight	25 KG
Size	880X430X540mm
Speed	2-3 km / h
Use of time Charge	8-12 hours Use: 1-2 hours
Charger output	Input AC100-240V DC6V500MA
Fuse	Resettable Fuse

Parts List

Part Number	Part Name	Picture	Q'ty (pcs)	Part Number	Part Name	Picture	Q'ty (pcs)
1	Main body		1	2	Head		1
3	Front fork plate		2	4	Front axle		1

Part Number	Part Name	Picture	Q'ty (pcs)	Part Number	Part Name	Picture	Q'ty (pcs)
5	Front fork		1	6	Wheel cover		2
7	Front Fender		1	8	Front wheel		1
9	Rear wheel		2	10	Wind shield		1
11	Seat		1	12	Trunk lid		1
13	Rear lamp		2	14	Screw		3
15	Rear axle		1	16	Screw +nut		4
17	Mirror		2	18	motor		1
19	Wrench		2	20	Charger		1
21	Gasket		8	22	Nut		4
				23	Steering Screw+ nut		1

Explosion map



①	Main body	⑪	Seat
②	Head	⑫	Trunk lid
③	Front fork plate	⑬	Rear lamp
④	Front axle	⑮	Rear axle
⑤	Front fork	⑯	Screw
⑥	Wheel cover	⑰	Mirror
⑦	Front Fender	⑱	Motor
⑧	Front wheel	⑲	Gasket
⑨	Rear wheel	⑳	Nut
⑩	Wind shield	㉓	Steering Screw

Assembling

- The vehicle should be assembled by adult before use. It will take 30 minutes to complete.
- The small parts might cause choke, please keep away from the children.
- Please check the number of the parts before assembling, and keep the packaging bags away from the children in case of choke.

1. Install the front fork assembly

First, remove the parts from the front fork assembly and insert the handle on the other side. The front fender is inserted into the front fork. Fasten the fork to the head with four screws.

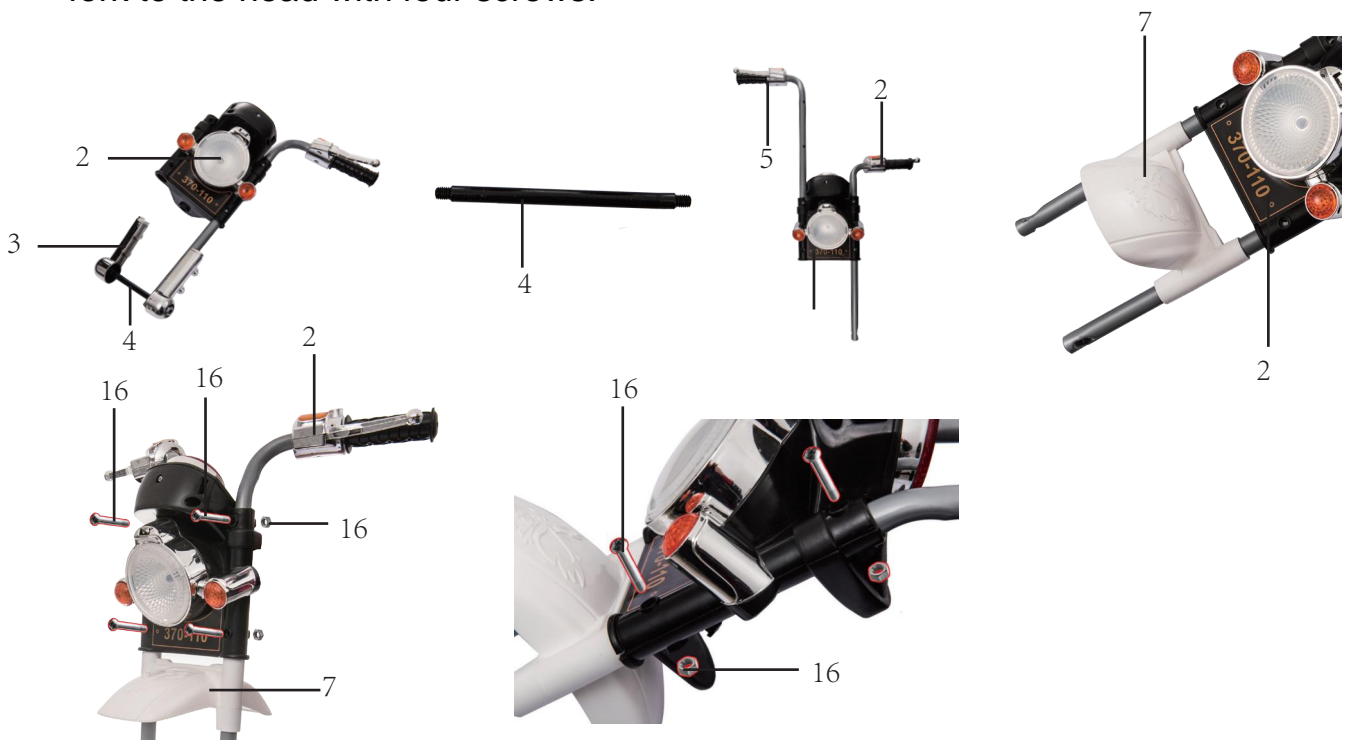

2. installation of front wheel

Pass the front axle through the gasket, front fork pipe, gasket, front wheel, gasket, front fork pipe and gasket from left to right. Install nuts at each end of the front shaft and tighten them with two wrenches.

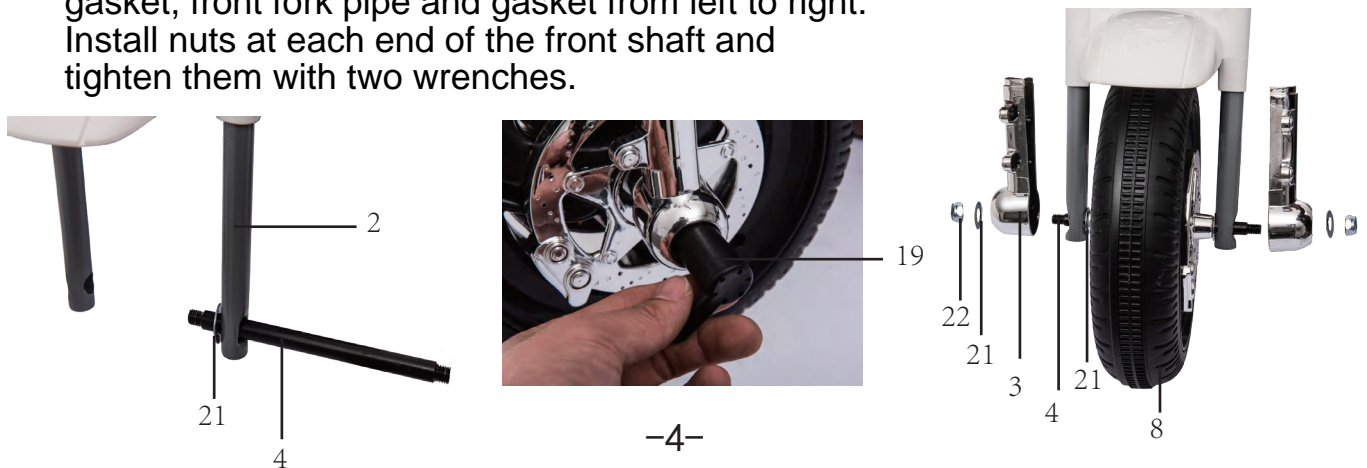

3. Install windshield

Insert the three legs of the windshield into the corresponding plastic bayonet of the dashboard until it doesn't fall off easily.



4. Front wheel assembly

First connect the joint of the light line, and insert the corresponding position of the front wheel assembly into the valve body, twist the front fork from top to bottom with a wrench, tighten the valve body, the front fork and the nut with the same diameter.

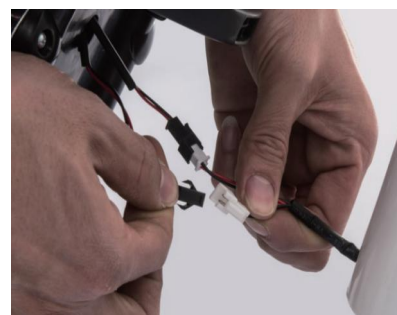

5. Rear wheel mounting

Install the gearbox under the right side of the body, hold the embossed rear axle, insert the gasket, the body, the gearbox, the rear wheel, the gasket from left to right, then insert the gasket, the rear wheel, the gasket from left to right, then lock the rear axle of the nut and finally buckle the wheel lid at the end.



6. Connect the power

As showed in the picture,connect the power plug-in with the right direction (red to red,black to black)



7. The installation of the toolbox

Position the cover of the toolbox at the bottom of the trunk seat behind the seat and fasten the two front buckles on the bottom of the trunk seat.

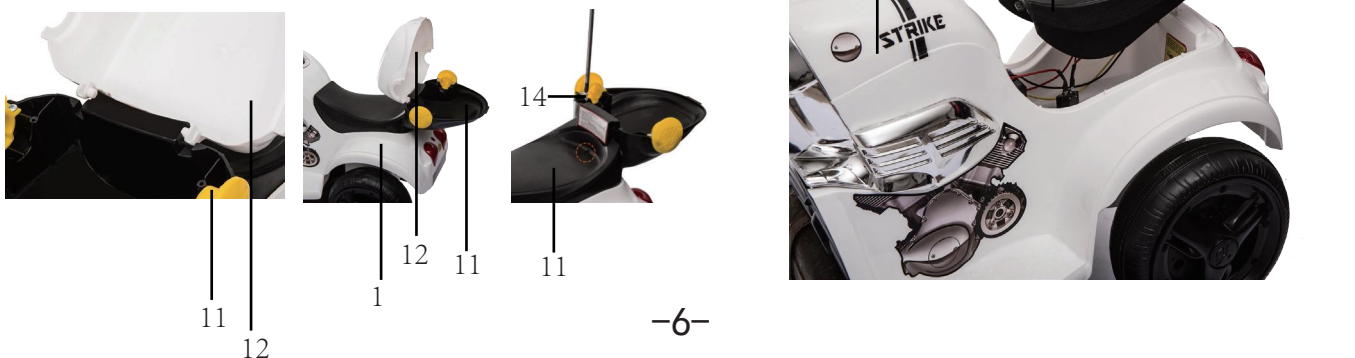

8. Rear tail light installation

As shown in the figure, use tapping screw to fix the taillight to the corresponding hole in the rear of the vehicle.

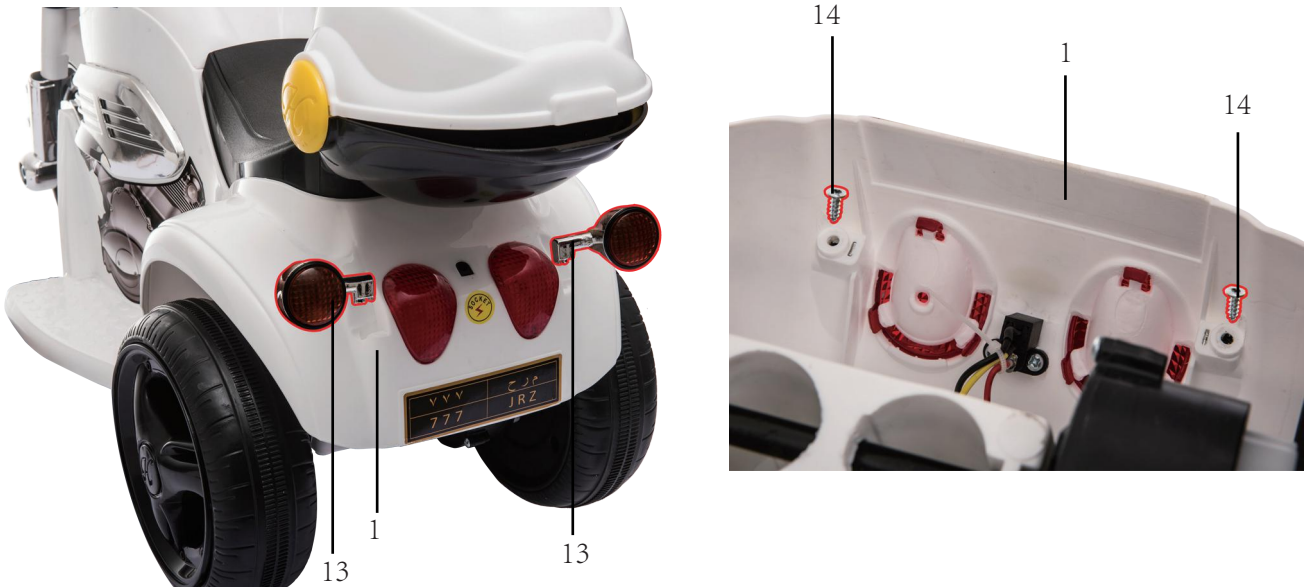

9. Installation of mirror

Place the left and right mirror in the corresponding holes in the front fork until they do not fall off easily.



Warnings

For children' s safety, please read these carefully.
Assembly and adjustment must be done by adults, keep children away.
Keep children under 18 months away from small parts.
Do not be close to fire.
Adult must teach how to play it and never leave children alone for playing.
Do not stand up or play when children are stepping on foot pedal.
Battery must be charged by adults only. Please charge it first before use.
Keep children away from plastic bag, or suffocation may occur.
Only use spare parts which provided by manufacturer.
Charger is not a toy for playing.
Maximum loading capacity is 25KG. Do not overload.
Suitable age: 18-60 months.

Charging notification

For the first use, please charge 10 hours, or will damage the battery.
Plug charger DC line into charge hole first, then plug charger into socket.
The product can not be played when it charging.
The product can not be charged for more than 18 hours each time.
It is normal that charger and battery warm (under 60°) during charging.
Do not charge if plug is wet, or will occur short-circuited.
Only use charger provided by manufacturer, or will damage charger and battery or occur short-circuited.If don't used it for a long time, make sure to charge it once a month.

Function



Button function
Horn button
Music button
Forward stop backward button
Power button

Charging steps are as follows:

Step 1 : The charging hole is under the trunk lid.

Step 2 : Put the charger plug into the plug hole.

Step 3 : Connect the charger to the power socket.

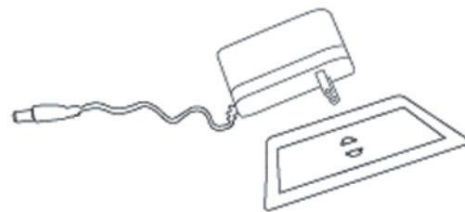

Warning: This product must be charged by adults only.

This product is useless during charging

Maintenance and Service

- Check battery, charger and other spare parts regularly. If any problem, please fix it before playing.
- Use lubricating oil to care iron parts. Keep car away from fire and sunshine.
- Park it on the even place, not reversal or gradient.
- Park it indoor and cover it with waterproof cloth.
- Keep car away from fire, like stove or heater, or plastic may melt.
- Keep away from flammable things, or may occur fire accident.
- Charge it after use and must be done by adults only.
- If not used for a long time, please charge the battery once a month to ensure the normal use of the battery.
- Clean the vehicle with dry cloth only. Do not use chemical solvent to wipe plastic parts. Do not wash it with water or play it when raining or snowing.
- When stop using the motorcycle, cut off the power, turn all the buttons to “ stop” or “ off” .
- Do not use inconsistent fuse.
- Do not change the line system, structure and additional electric system of the vehicle by yourself, repair work must be done by career man or under professional supervision.

If you have any questions, please contact our customer care center.

Our contact details are below:



0044-800-240-4004



enquiries@mhstar.co.uk

IMPORTER ADDRESS:
MH STAR UK LTD
Unit 27, Perivale Park,
Horsenden lane South
Perivale, UB6 7RH
MADE IN CHINA

MALFUNCTION ELIMINATES:

Vehicle couldn't move	1,Check whether the power switch is off.
	2,Check whether the forward/backward switch is in the neutral gear (in the middle)
	3,Check the fuse is damaged,if so ,change it.
	4,Check whether the battery wires are connected well?
	5,Charger's dc in the charging socket will make it not work,if so ,take it out.
	6,Check whether stepped on the pedal.
	7,Check whether anything trapped in the wheels.
Vehicle move slowly	1,Check whether the battery be fully charged.
	2,Check whether anything trapped in the wheels.
	3,Check whether the vehicle is over loaded.
Vehicle cannot be charged	1,Check whether the charger or battery is damaged.
	2,Check whether the charger and the battery is well connected.
	3,The charger or battery if there is a loose connection.

WARNING

1,This note is to use illustrations to illustrate the operation of the product and product structure, there are a few differences, in kind prevail.

2,In order to improve the quality of the products, under the condition of without telling, we may make changes to the product part of the structure with the appearance, please understanding

