

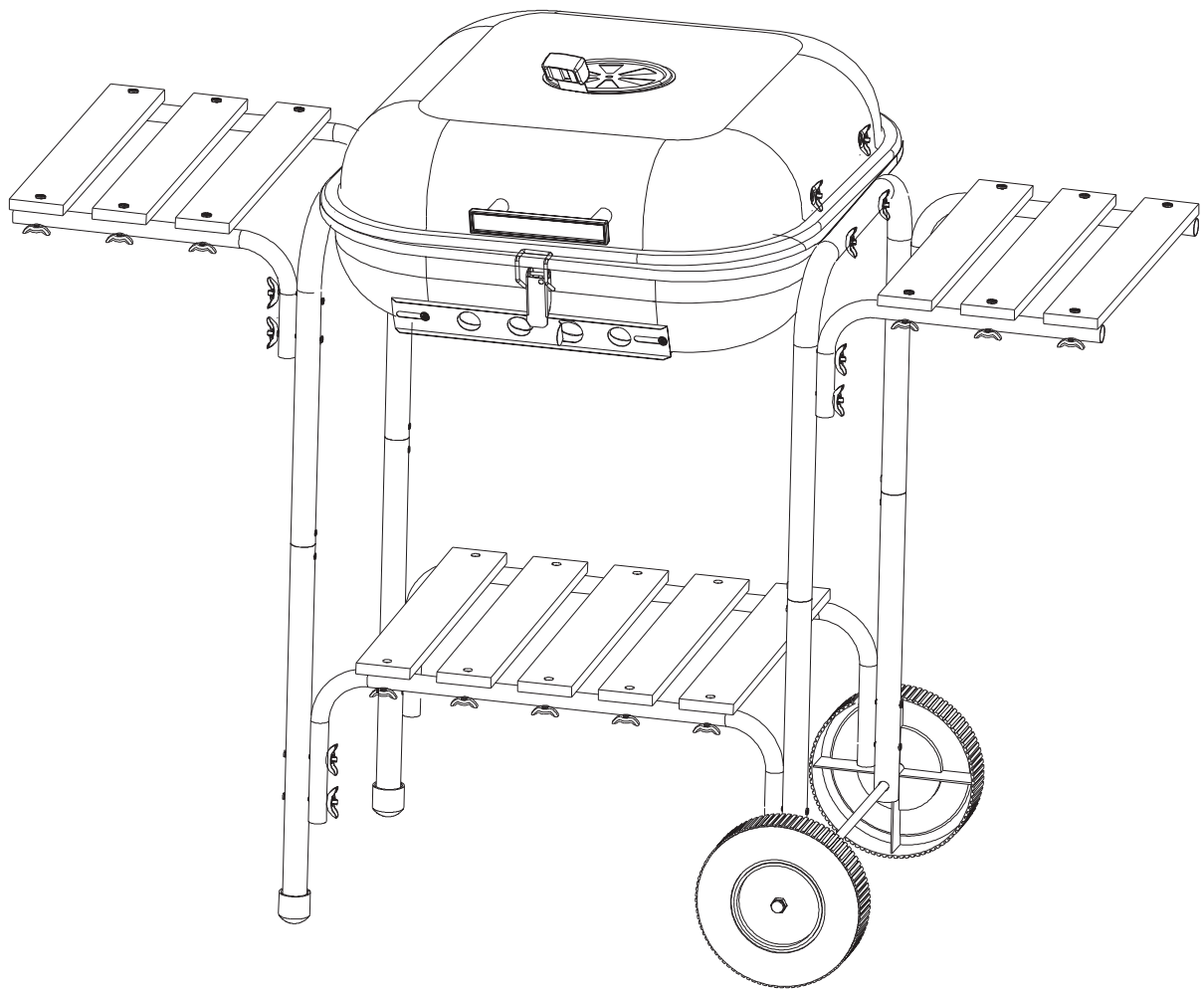

IN230500013V01\_UK\_FR\_ES\_DE\_IT

**846-043**



**EN\_IMPORTANT, RETAIN FOR FUTURE REFERENCE: READ CAREFULLY.**

**FR\_IMPORTANT: A LIRE ATTENTIVEMENT ET À CONSERVER POUR CONSULTATION  
ULTÉRIEURE.**

**ES\_IMPORTANTE, LEA Y GUARDE PARA FUTURAS REFERENCIAS.**

**DE\_, WICHTIG! SORGFÄLTIG LESEN UND FÜR SPÄTER NACHSCHLAGEN AUFBEWAHREN."**

**IT\_IMPORTANTE! CONSERVARE IL PRESENTE MANUALE PER FUTURO RIFERIMENTO E  
LEggerlo attentamente.**

## IMPORTANT SAFEGUARDS



### READ ALL INSTRUCTIONS BEFORE USE.

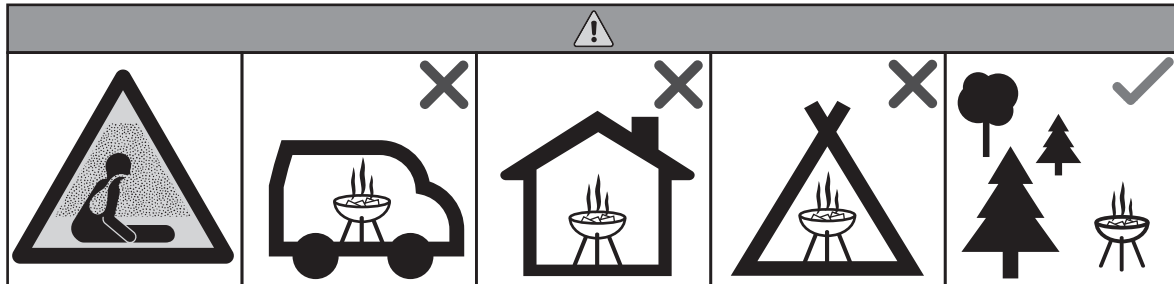

- The barbecue shall be heated up and the fuel kept red hot for at least 30 min prior to the first cooking.
- Do not use this product indoors or in enclosed areas (e.g., tents) even if ventilation is provided, and do not store the product indoors with freshly used coals; burning charcoal releases carbon monoxide, which is toxic to humans and animals.
- **DO NOT** use near flammable or combustible objects or materials.
- Do not cook before the fuel has a coating of ash.
- The barbecue shall be heated up and the fuel kept red hot for at least 30min prior to the first cooking.
- **WARNING!** This barbecue will become very hot, do not move it during operation.
- Do not use indoors!
- **WARNING!** Do not use spirit or petrol for lighting or re-lighting!
- Use only firelighters complying to EN 1860-3!
- **WARNING!** Keep children and pets away.
- The maximum amount of charcoal shall not exceed 1.0kg.
- Keep out of the reach of children and pets. Extra caution is necessary when using this product near children.
- Do not use this product if you are under the influence of alcohol or prescription/non-prescription drugs, as these substances may impair your ability to safely use the product.
- Do not leave the product unattended while it is in use.
- Do not move the product while it is in use or hot; allow the product to cool completely before handling.
- Ensure the product is fully and securely assembled before each use.
- Keep hair, clothing, and jewelry away from the coals when lighting and away from flames.
- Do not touch hot surfaces; always wear protective, heat-resistant mitts/gloves when using this product.
- Do not use this product on or near recreational vehicles or boats.
- Do not insert use paper, cardboard, or similar material into the flames or coals.
- Do not repair or repaint the product; discard if damaged.
- Do not build large fires in this product; it is intended for small fires only.
- Always place the product on a flat, level, stable, heat-resistant surface.
- When the appliance is in use, the handle can reach extreme temperatures that can cause serious injury to an unprotected hand. Use an appropriate heat resistant glove or pad when handling.
- The necessity for maintaining proper clearances from combustible construction is 10 feet (3 M).., which is the specific minimum clearances from such construction to the sides and back of the outdoor appliance, and that the appliance shall not be used under overhead combustible construction.
- This product is intended solely for outdoor, non-commercial use in cooking foods for human consumption; do not use for any other purpose.
- Do not use water to extinguish coals or cool the product.
- Do not use attachments not recommended or sold by the product manufacturer.
- Always use heat-resistant utensils with the product.

## PROTECTIONS IMPORTANTES



### LISEZ TOUTES LES INSTRUCTIONS AVANT L'UTILISATION.

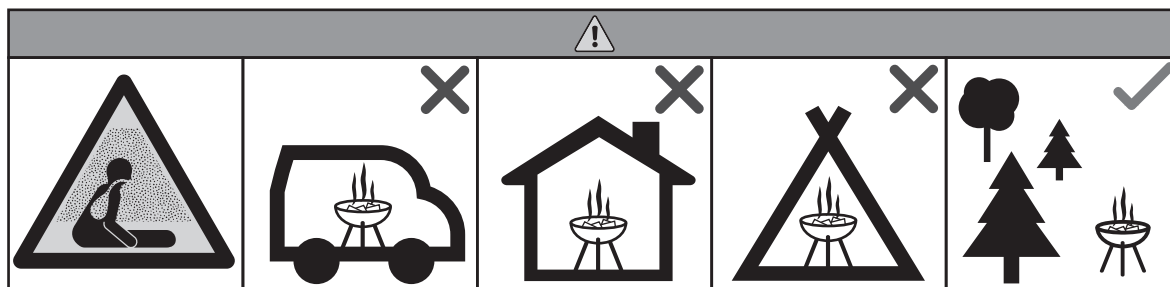

- Le barbecue doit être chauffé et le combustible doit être maintenu chaud pendant au moins 30 minutes avant la première cuisson.
- N'utilisez pas ce produit à l'intérieur ou dans les endroits clos (par exemple: tentes) même si la ventilation est fournie, et ne stockez pas le produit à l'intérieur avec des charbons fraîchement utilisés; le charbon de bois brûle du monoxyde de carbone, qui est toxique pour les humains et les animaux.
- NE PAS utiliser à proximité d'objets ou de matériaux inflammables ou combustibles.
- AVERTISSEMENT ! Ce barbecue deviendra très chaud, ne le déplacez pas pendant le fonctionnement
- Ne l'utilisez pas à l'intérieur !
- AVERTISSEMENT ! N'utilisez pas d'alcool ni d'essence pour allumer ou rallumer le feu !
- Utilisez uniquement des allume-feu conformes à la norme EN 1860-3 !
- AVERTISSEMENT ! Tenez les enfants et les animaux domestiques à l'écart.
- La quantité de charbon de bois ne doit pas dépasser 1.0 kg.
- Tenez hors de la portée des enfants et des animaux de compagnie. Une prudence accrue est nécessaire lors de l'utilisation du produit à proximité d'enfants .
- N'utilisez pas ce produit si vous êtes sous l'influence de l'alcool ou des médicaments sur ordonnance ou en vente libre, car ces substances peuvent nuire à votre capacité d'utiliser le produit en toute sécurité.
- Ne laissez pas le produit sans surveillance pendant son utilisation.
- Ne déplacez pas le produit pendant qu'il est utilisé ou chaud ; laissez refroidir complètement le produit avant la manipulation.
- Veuillez à ce que le produit soit entièrement et bien assemblé avant chaque utilisation.
- Tenez les cheveux, les vêtements et les bijoux à l'écart des charbons lors de l'éclairage et des flammes.
- Ne touchez pas les surfaces chaudes ; portez toujours des mitaines/gants protecteurs et résistants à la chaleur lorsque vous utilisez ce produit.
- N'utilisez pas ce produit sur ou à proximité de véhicules de loisirs ou de bateaux.
- N'insérez pas de papier d'utilisation, de carton ou de matières similaires dans les flammes ou les charbons.
- Ne réparez pas ou repeignez le produit ; jetez-le en cas d'endommagement.
- Ne pas construire de grands feux dans ce produit; il est destiné aux petits feux seulement.
- Placez toujours le produit sur une surface plate, stable et résistante à la chaleur.
- Lorsque l'appareil est utilisé, la poignée peut atteindre des températures extrêmes qui peuvent causer de graves blessures à une main non protégée. Utilisez un gant ou un tampon résistant à la chaleur approprié lors de la manipulation.
- La nécessité de maintenir des dégagements appropriés de la construction combustible est de 10 pieds (3 M), qui est le minimum spécifique de dégagements de cette construction sur les côtés et à l'arrière de l'appareil extérieur et l'appareil ne doit pas être utilisé sous la construction de combustibles en hauteur.
- Ce produit est destiné uniquement à l'extérieur, et à des fins non commerciales pour la cuisson d'aliments destinés à la consommation humaine ; n'utilisez pas à d'autres fins.
- N'utilisez pas d'eau pour éteindre les charbons ou refroidir le produit.
- N'utilisez pas de pièces jointes non recommandées ou vendues par le fabricant du produit.
- Utilisez toujours des ustensiles résistants à la chaleur avec le produit.

## SALVAGUARDIAS IMPORTANTES



### LEA TODAS LAS INSTRUCCIONES ANTES DEL USO.

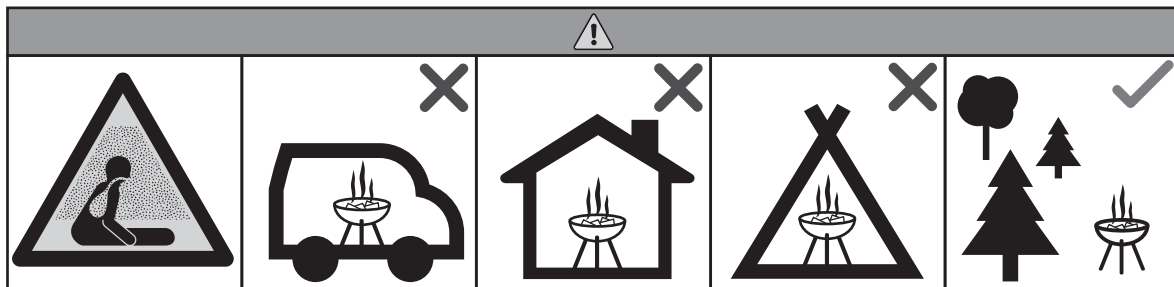

- La parrilla de barbacoa debe calentarse y el combustible debe permanecer al rojo y caliente durante al menos 30 minutos antes de cocinar por la primera vez.
- No use este producto en interiores o en áreas cerradas (por ejemplo, carpas) incluso si se proporciona ventilación, y no almacene el producto en interiores con carbón recién utilizado; quemar carbón libera monóxido de carbono es tóxico para humanos y animales.
- NO utilice la parrilla de barbacoa cerca de los objetos o materiales inflamables o combustibles.
- ¡ADVERTENCIA! Esta barbacoa se calentará mucho durante el uso, no la mueva durante su funcionamiento.
- ¡No la utilice en interiores!
- ¡ADVERTENCIA! ¡No utilice alcohol o gasolina para encender o reencender la barbacoa!
- ¡Utilice únicamente el encendedor que cumpla la norma EN 1860-3!
- ¡ADVERTENCIA! Manténgala alejados a los niños y a los animales domésticos.
- La cantidad máxima de carbón vegetal cargado no debe superar los 1.0 kg.
- Mantenga fuera del alcance de los niños y animales domésticos. La precaución adicional es necesaria cuando se usa este producto cerca de los niños.
- No utilice este producto si está bajo la influencia del alcohol o medicamentos recetados / no recetados, ya que estas sustancias pueden afectar su capacidad de usar el producto de manera segura.
- No deje el producto desatendido cuando esté en uso.
- No mueva el producto cuando esté en uso o sea caliente; deje que el producto se enfríe completamente antes de manipularlo.
- Asegúrese de que el producto esté ensamblado completamente y seguramente antes de cada uso.
- Mantenga el cabello, la ropa y las joyas lejos de las brasas cuando se enciende y lejos de las llamas.
- No toque las superficies calientes; siempre use guantes / guantes protectores resistentes al calor cuando use este producto.
- No use este producto en o cerca de vehículos recreativos o botes.
- No inserte papel, cartón o material similar en las llamas o carbones.
- No repare ni repinte el producto; deseché si está dañado.
- No encienda fuegos grandes en este producto; este producto está destinado solo a incendios pequeños.
- Coloque siempre el producto sobre una superficie plana, nivelada, estable y resistente al calor.
- Cuando el producto está en uso, el mango puede alcanzar temperaturas extremas, lo que pueden causar lesiones graves en una mano desprotegida. Use un guante o almohadilla resistente al calor apropiado cuando lo manipule.
- Debe mantener espacios libres apropiados de la construcción combustible de 10 pies (3 M), lo que son los espacios libres mínimos específicos de tal construcción a los lados y la parte posterior del aparato exterior, y que el aparato debe ser usado debajo de una construcción combustible elevada.
- Este producto está destinado exclusivamente para uso al aire libre, uso no comercial en la cocción de alimentos para consumo humano; no lo use para ningún otro propósito.
- No use agua para apagar las brasas o enfriar el producto.
- No use accesorios no recomendados o vendidos por el fabricante del producto.
- Use siempre utensilios resistentes al calor con el producto.

## WICHTIGE SICHERHEITSMASSNAHMEN



### LESEN SIE ALLE ANWEISUNGEN VOR DEM GEBRAUCH.

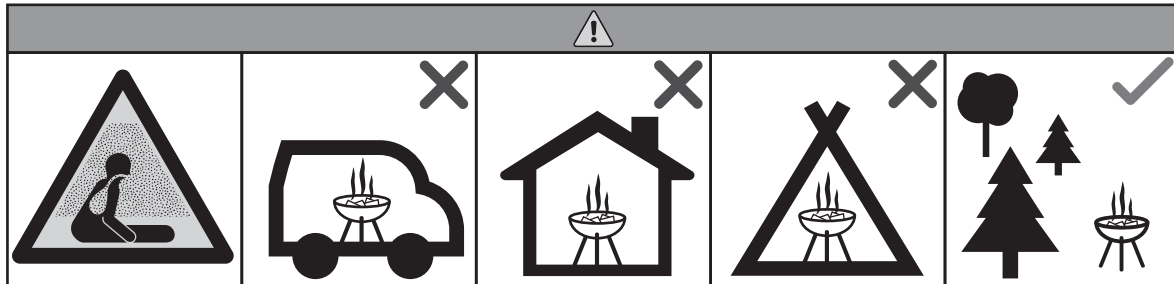

- Vor dem ersten Kochen muss der Grill aufgeheizt und der Brennstoff mindestens 30 Minuten lang glühend heiß gehalten werden.
- Verwenden Sie dieses Produkt nicht in Innenräumen oder geschlossenen Räumen (z. B. Zelten), auch wenn Belüftung vorhanden ist, und lagern Sie das Produkt nicht mit frisch verwendeter Kohle in Innenräumen. Beim Verbrennen von Holzkohle wird Kohlenmonoxid freigesetzt, das für Mensch und Tier giftig ist.
- NICHT in der Nähe von entzündlichen oder brennbaren Gegenständen oder Materialien verwenden.
- **WARNUNG!** Dieser Grill wird sehr heiß, bewegen Sie ihn nicht während des Betriebs
- Verwenden Sie ihn nicht in Innenräumen!
- **WARNUNG!** Kein Spiritus oder Benzin zum Anzünden oder Nachzünden verwenden!
- Verwenden Sie nur Feueranzünder, die der EN 1860-3 entsprechen!
- **WARNUNG!** Halten Sie Kinder und Haustiere fern.
- Die maximale Menge an Holzkohle darf 1.0 kg nicht überschreiten.
- Es darf nicht in die Hände von Kindern und Haustieren gelangen. Bei der Verwendung dieses Produkts in der Nähe von Kindern ist besondere Vorsicht geboten.
- Verwenden Sie dieses Produkt nicht, wenn Sie unter dem Einfluss von Alkohol oder verschreibungspflichtigen / nicht verschreibungspflichtigen Arzneimitteln stehen, da diese Substanzen Ihre Fähigkeit zur sicheren Verwendung des Produkts beeinträchtigen können.
- Lassen Sie das Produkt nicht unbeaufsichtigt, während es verwendet wird.
- Bewegen Sie das Produkt nicht, wenn es verwendet wird oder heiß ist. Lassen Sie das Produkt vor der Handhabung vollständig abkühlen.
- Stellen Sie vor jedem Gebrauch sicher, dass

das Produkt vollständig und sicher montiert ist.

- Halten Sie Haare, Kleidung und Schmuck von der Glut fern und halten Sie sie von Flammen fern.
- Berühren Sie keine heißen Oberflächen. Tragen Sie immer hitzebeständige Schutzhandschuhe, wenn Sie dieses Produkt verwenden.
- Verwenden Sie dieses Produkt nicht in oder in der Nähe von Freizeitfahrzeugen oder Booten.
- Setzen Sie kein Papier, Pappe oder ähnliches Material in die Flammen oder Kohlen ein.
- Reparieren oder lackieren Sie das Produkt nicht neu. Bei Beschädigung entsorgen Sie es.
- Bauen Sie in diesem Produkt keine großen Feuer. Es ist nur für kleine Feuer gedacht.
- Stellen Sie das Produkt immer auf eine flache, ebene, stabile und hitzebeständige Oberfläche.
- Während des Gebrauchs des Geräts kann der Griff extreme Temperaturen erreichen, die eine ungeschützte Hand schwer verletzen können. Verwenden Sie beim Umgang einen geeigneten hitzebeständigen Handschuh oder ein Polster.
- Für die Einhaltung der richtigen Abstände zur brennbaren Konstruktion sind 3 m (10 Fuß) erforderlich. Dies ist der spezifische Mindestabstand von einer solchen Konstruktion zu den Seiten und der Rückseite des Außengeräts, und das Gerät darf nicht bei brennbaren Überkopfkonstruktionen verwendet werden
- Dieses Produkt ist ausschließlich für den nicht-gewerblichen Gebrauch im Freien zum Kochen von Lebensmitteln für den menschlichen Verzehr bestimmt, und darf nicht für andere Zwecke verwendet werden.
- Verwenden Sie kein Wasser, um Kohlen zu löschen oder das Produkt abzukühlen.
- Verwenden Sie keine Zubehörteile, die nicht vom Produkthersteller empfohlen oder verkauft werden.
- Verwenden Sie für das Produkt immer hitzebeständige Utensilien.

## IMPORTANTI NOTE DI SICUREZZA



### LEGGERE TUTTE LE ISTRUZIONI PRIMA DELL'USO.

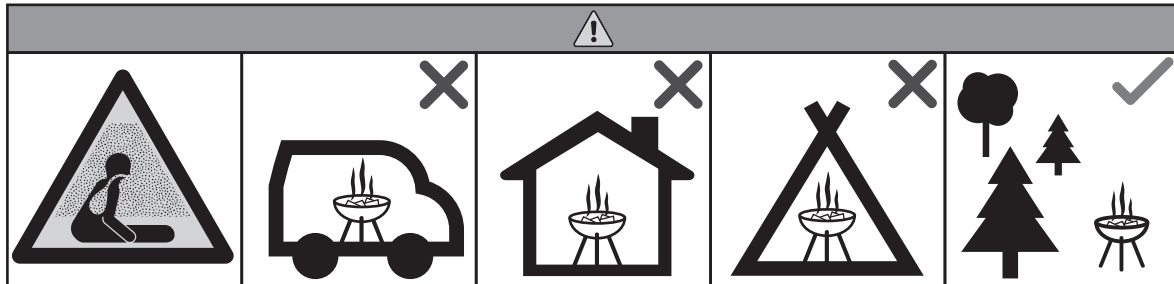

- Il barbecue deve essere riscaldato e il combustibile deve essere mantenuto rovente per almeno 30 minuti prima della prima cottura.
- Non usare questo prodotto in ambienti domestici o in aree chiuse (es. tende) anche se vi è ventilazione, e non conservare il prodotto al chiuso con carboni ancora ardenti; i carboni ardenti rilasceranno monossido di carbonio, che è tossico per umani e animali.
- **NON** utilizzare vicino a oggetti o materiali infiammabili o combustibili.
- **AVVERTENZA!** Questo barbecue diventerà molto caldo, non spostarlo durante l'utilizzo.
- Non utilizzarlo in ambienti chiusi!
- **AVVERTENZA!** Non utilizzare alcol o benzina per accendere o riaccendere!
- Utilizzare solo accendifuoco conformi alla EN 1860-3!
- **AVVERTENZA!** Tenere i lontani bambini e animali domestici.
- La quantità massima di carbone non deve superare 1.0 kg.
- Tenere fuori dalla portata dei bambini e degli animali domestici. Usare prudenza aggiuntiva quando è necessario usare il prodotto in prossimità di bambini.
- Non usare questo prodotto se siete sotto l'influenza di alcol o di medicinali prescritti e non, in quanto queste sostanze limiteranno la vostra abilità di utilizzare il prodotto in modo sicuro.
- Non lasciare il prodotto senza diretta supervisione quando in uso.
- Non muovere il prodotto quando in uso o quando incandescente. Lasciare che si raffreddi completamente prima di maneggiarlo.
- Assicurarsi che il prodotto sia assemblato completamente e in sicurezza prima di ogni uso.
- Tenere i capelli, vestiti, e i gioielli lontano dai tizzoni ardenti e dalle fiamme vive.
- Non toccare le superfici incandescenti; indossare sempre guanti protettivi e resistenti al calore quando usate il prodotto.
- Non usare questo prodotto su o vicino a roulotte o barche.
- Non inserire carta, cartone, o materiali simili nelle fiamme o tra i tizzoni.
- Non riparare o riverniciare il prodotto; smaltire se danneggiato.
- Non accendere fuochi troppo grandi in questo prodotto; è progettato solo per focolari di piccole dimensioni.
- Posizionare sempre su una superficie piana, livellata, stabile, e resistente al calore.
- Quando il prodotto è in uso, il manico può raggiungere temperature estreme che possono causare lesioni gravi alle mani non protette. Usare gli appropriati guanti resistenti al calore quando lo maneggiate.
- È necessario mantenere uno spazio libero di almeno 10ft (3m) dal combustibile, che è lo spazio minimo consentito dai lati e dal retro di questo tipo di prodotto, e il prodotto non può essere utilizzato sotto del combustibile posizionato a; di sopra dello stesso.
- Questo prodotto è pensato solo per uso all'aperto, uso non commerciale per cucinare cibo commestibile; non usare per altri scopi.
- Non usare acqua per spegnere i carboni ardenti o raffreddare il prodotto.
- Non usare gli accessori che non sono consigliati o venduti dal produttore.
- Usare sempre utensili resistenti al calore quando con questo prodotto.

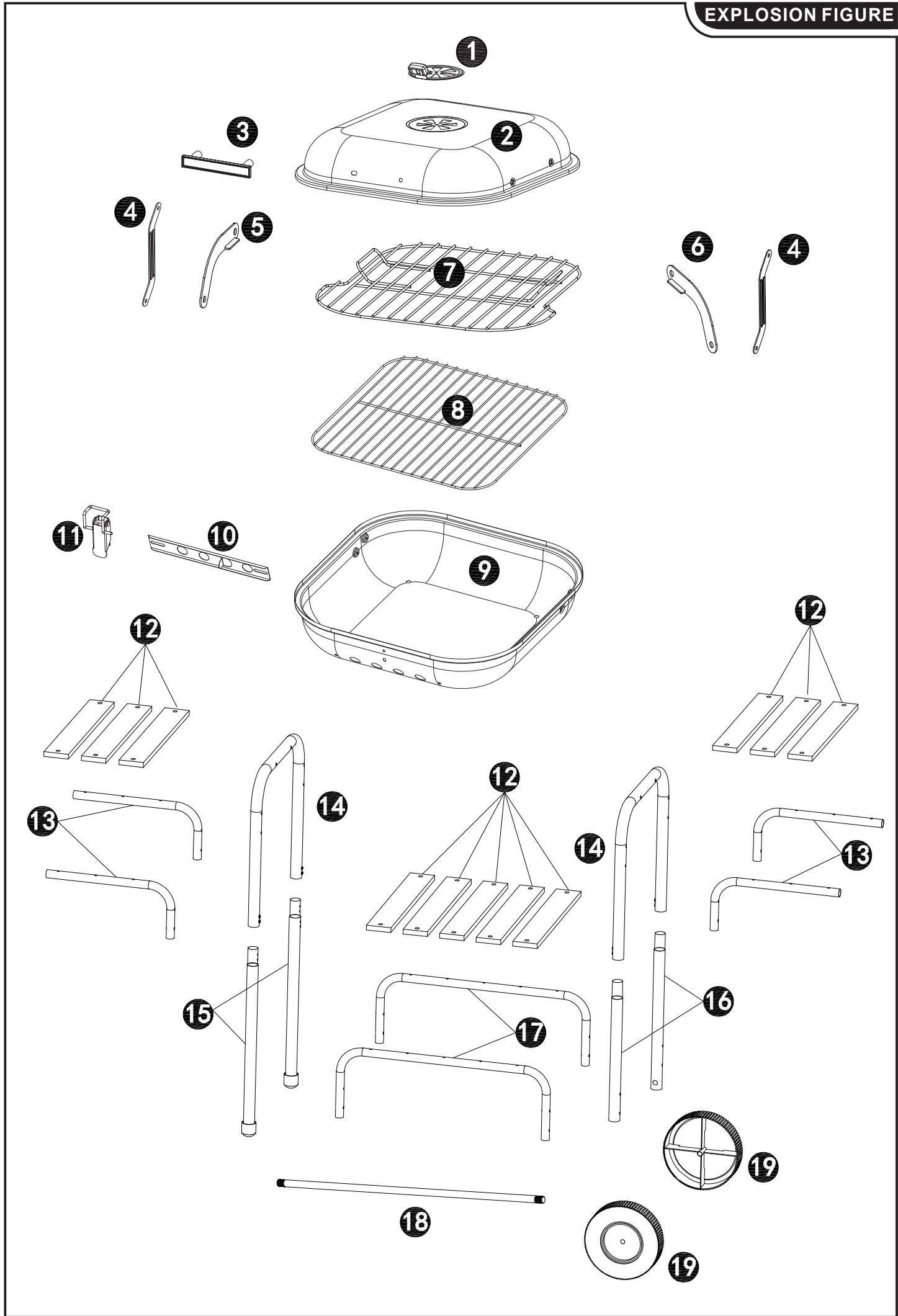

① x 1

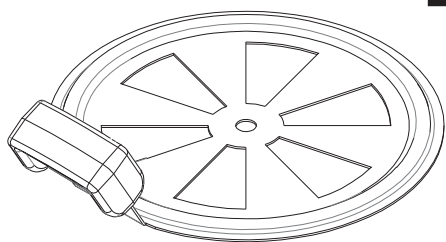

② x 1

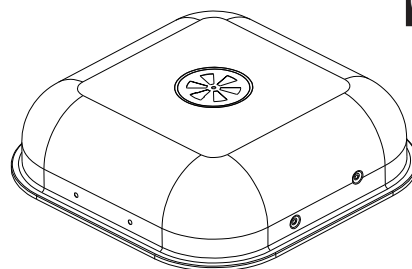

③ x 1

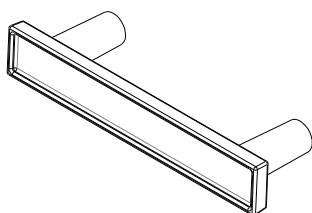

④ x 2



⑤ x 1

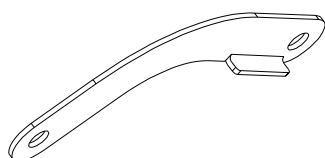

⑥ x 1

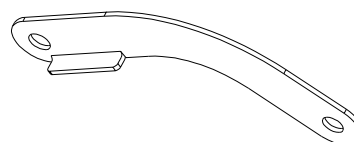

⑦ x 1

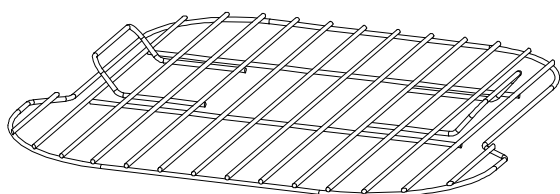

⑧ x 1

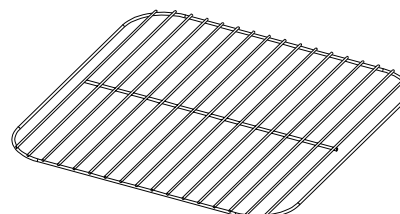

⑨ x 1

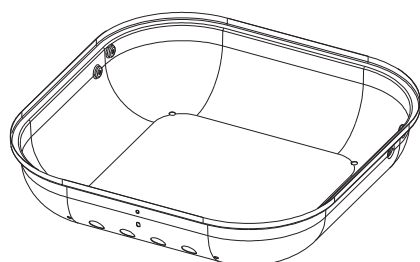

⑩ x 1

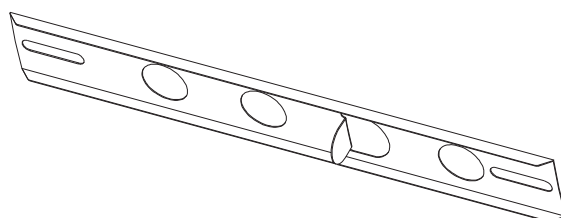

⑪ x 1

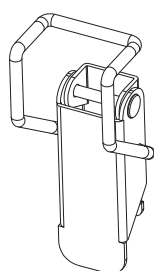

⑫ x 11

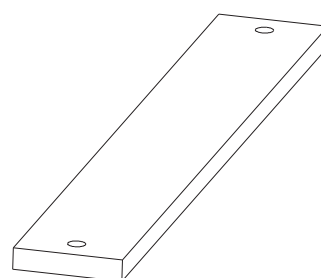



**PARTS**

**13** x 4

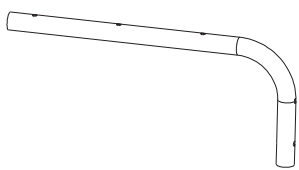

**14** x 2

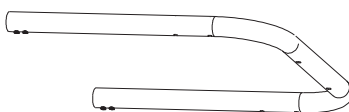

**15** x 2

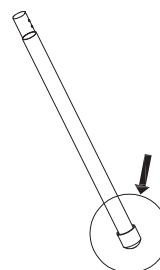

**16** x 2

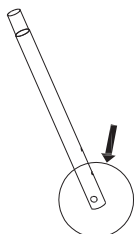

**17** x 2

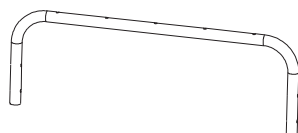

**18** x 1

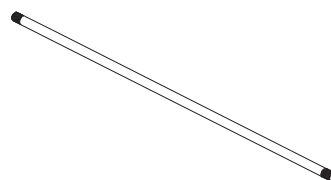

**19** x 2

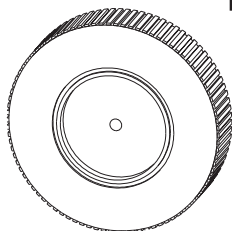

**HARDWARE**

**A** x 16  
M5\*45

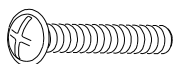

**B** x 4  
M5\*30

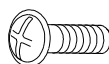

**C** x 22  
M4\*30

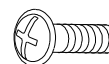

**D** x 2  
M6\*12



**E** x 11  
M5\*12



**F** x 2  
M4



**G** x 2  
M4\*8



**H** x 31  
M5



**I** x 22  
M4



**J** x 2  
M8





**K** x 4  
Ø6\*18

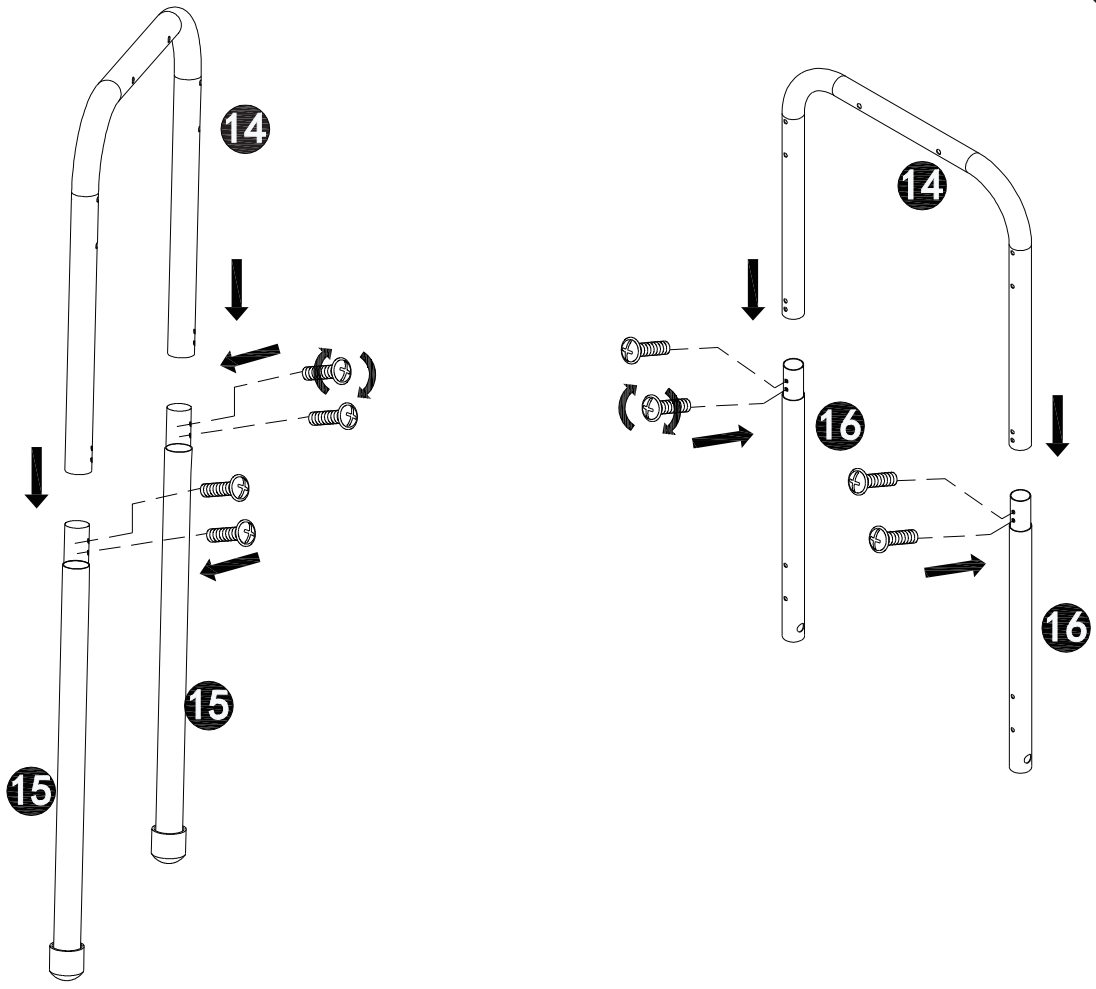
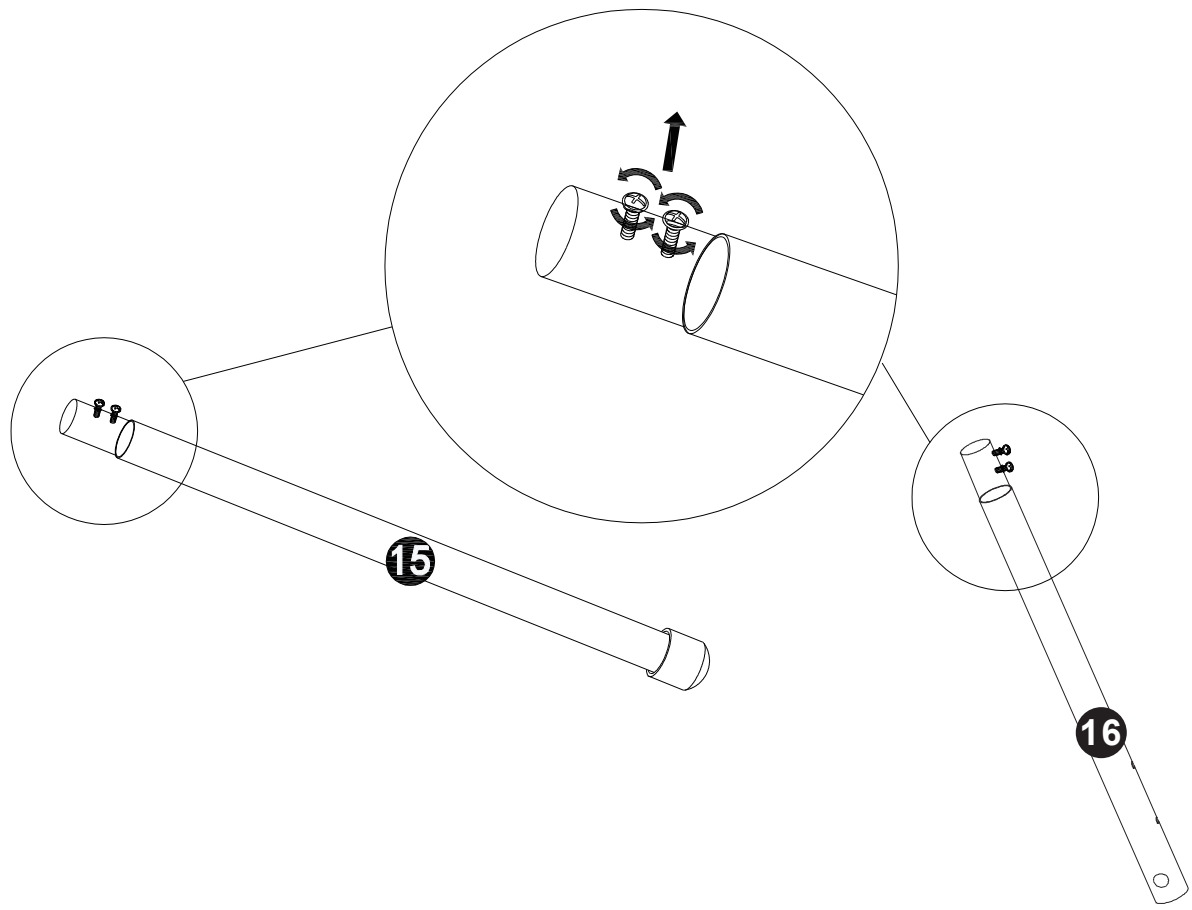

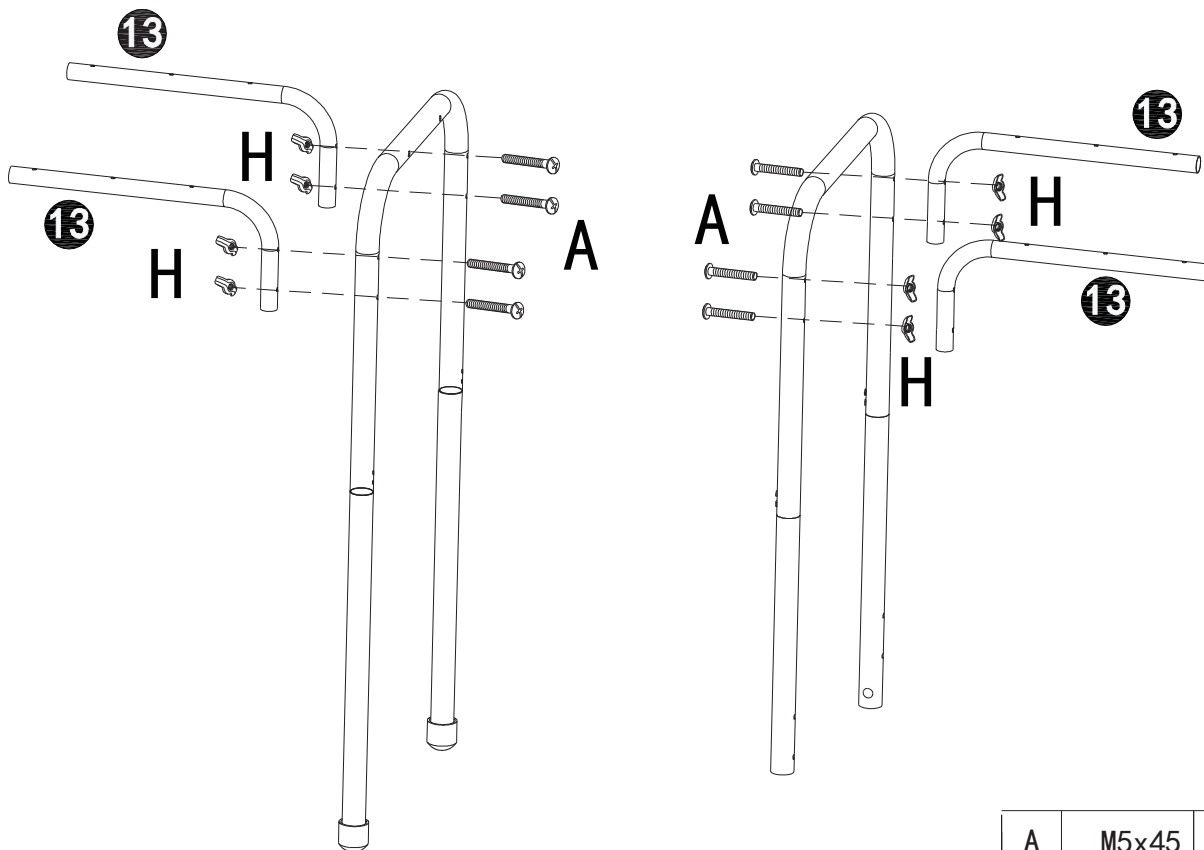





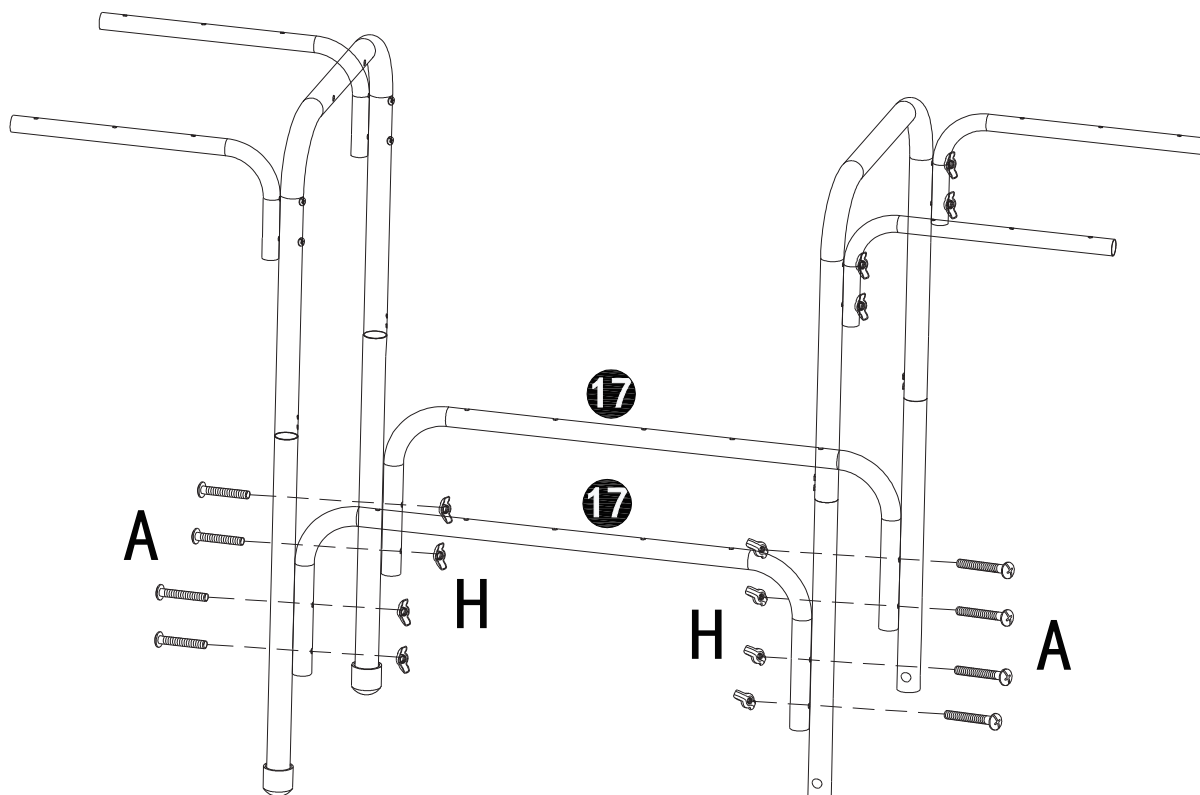

A	M5x45	H	M5
 x 8		 x 8	



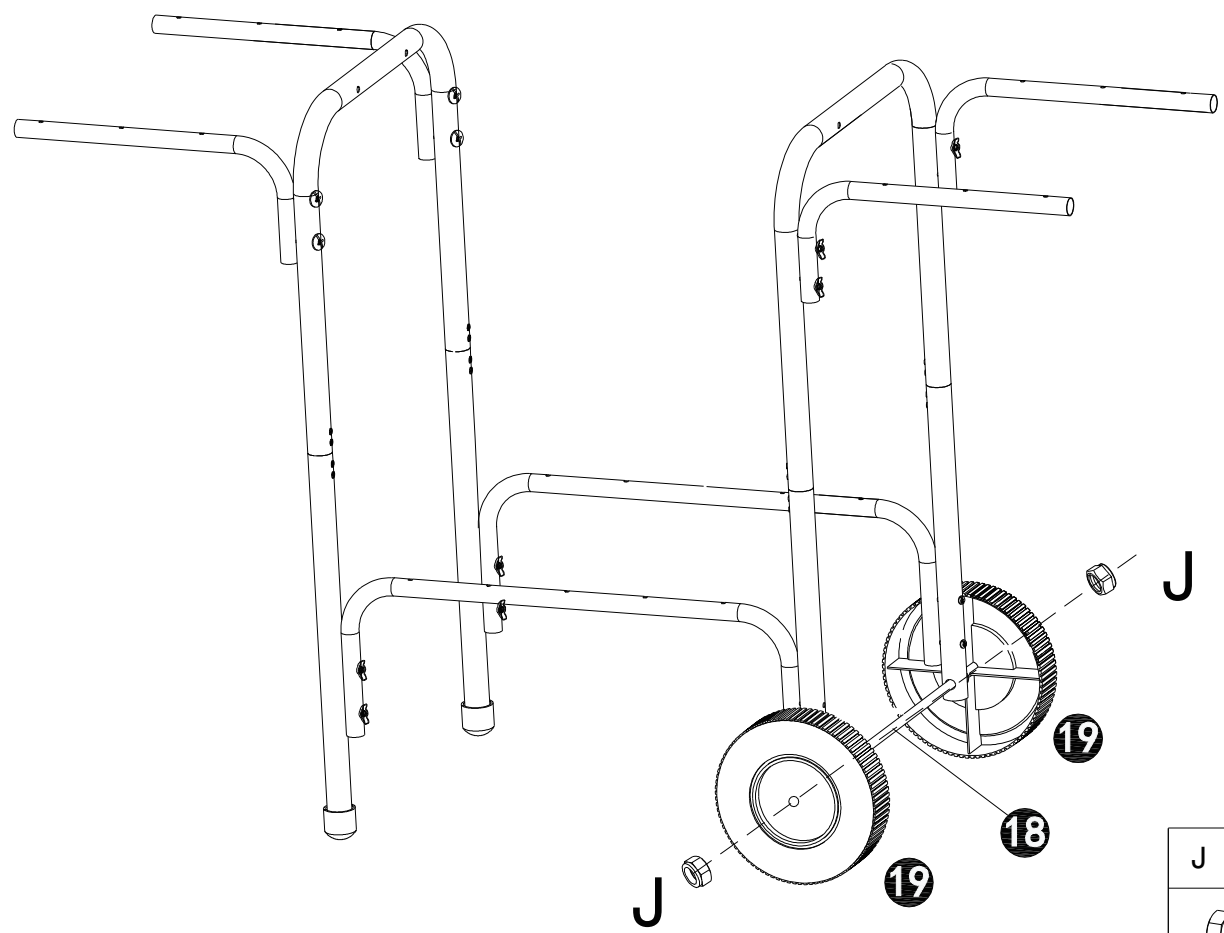

A	M5x45	H	M5
 x 8		 x 8	



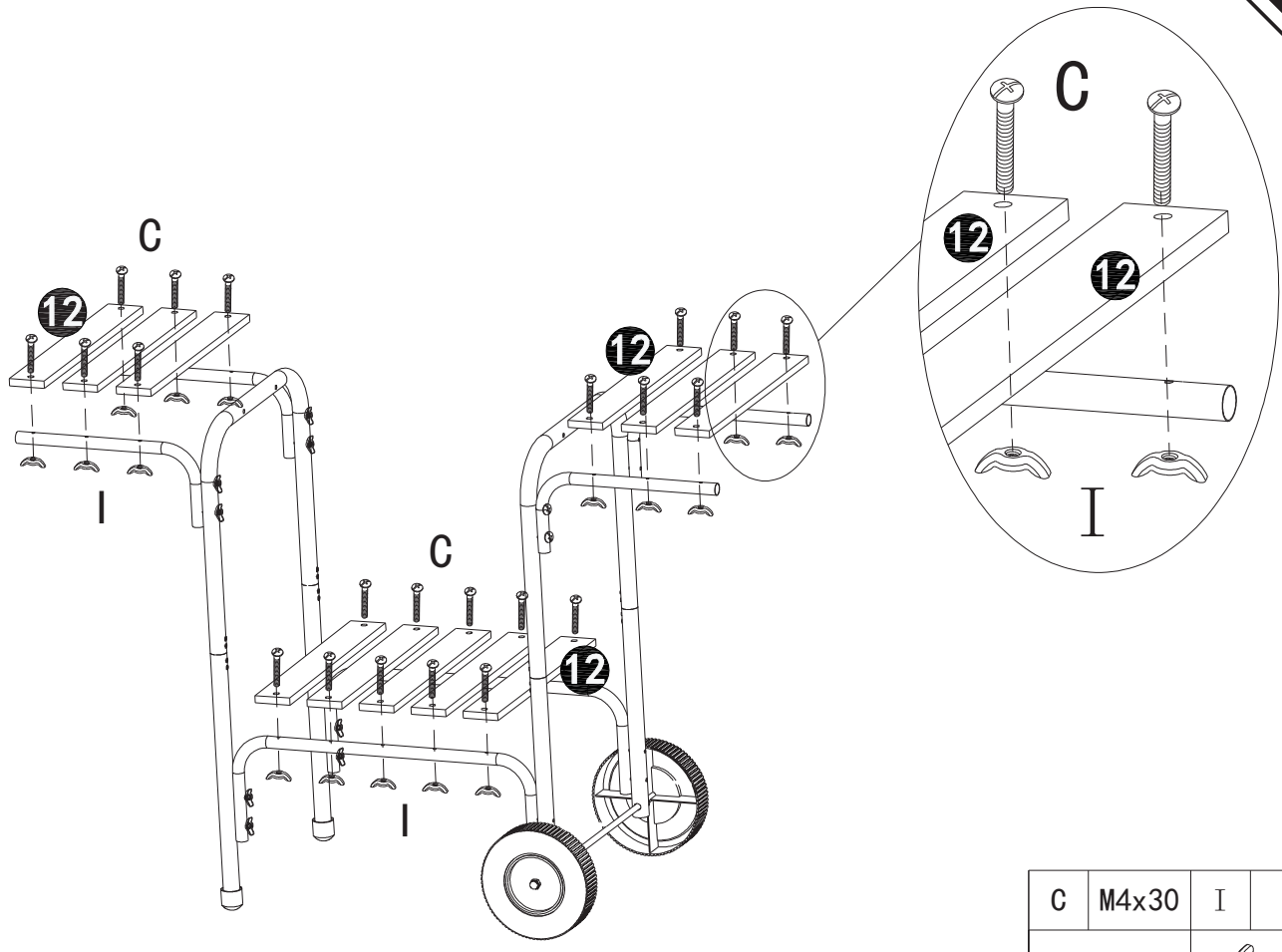

J	M8
 x 2	



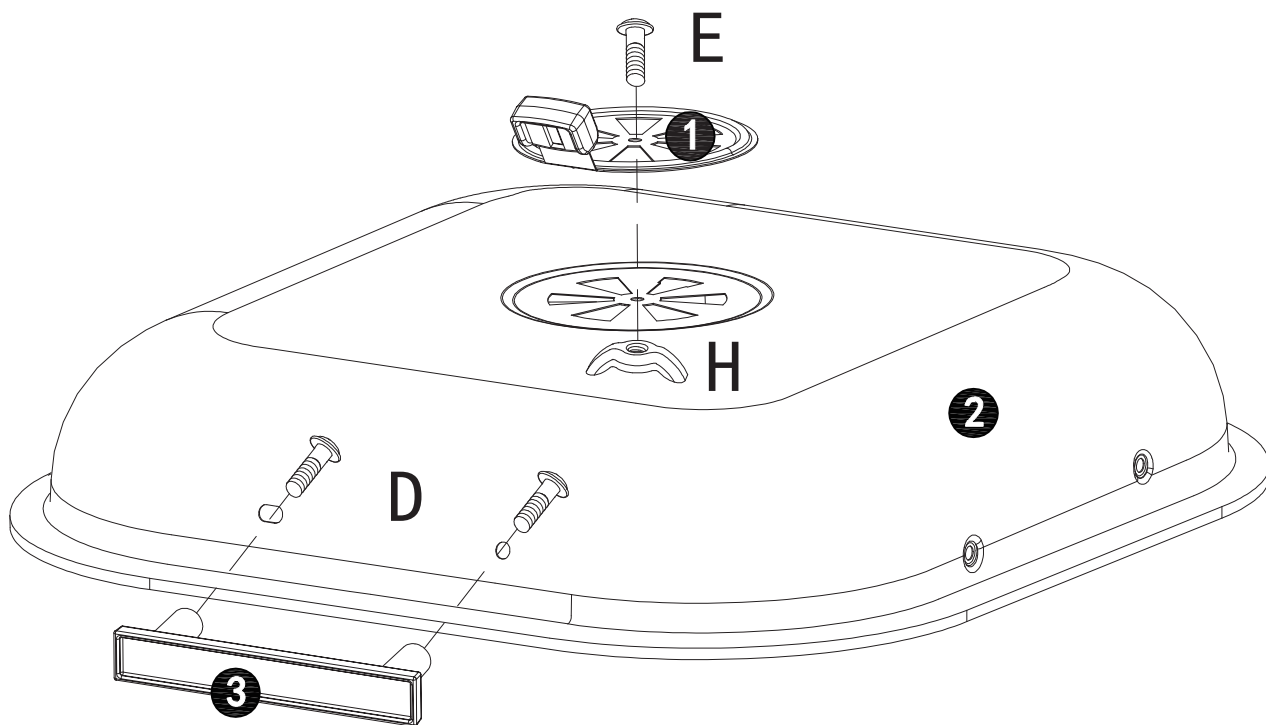



C	M4x30	I	M4
 x 22		 x 22	

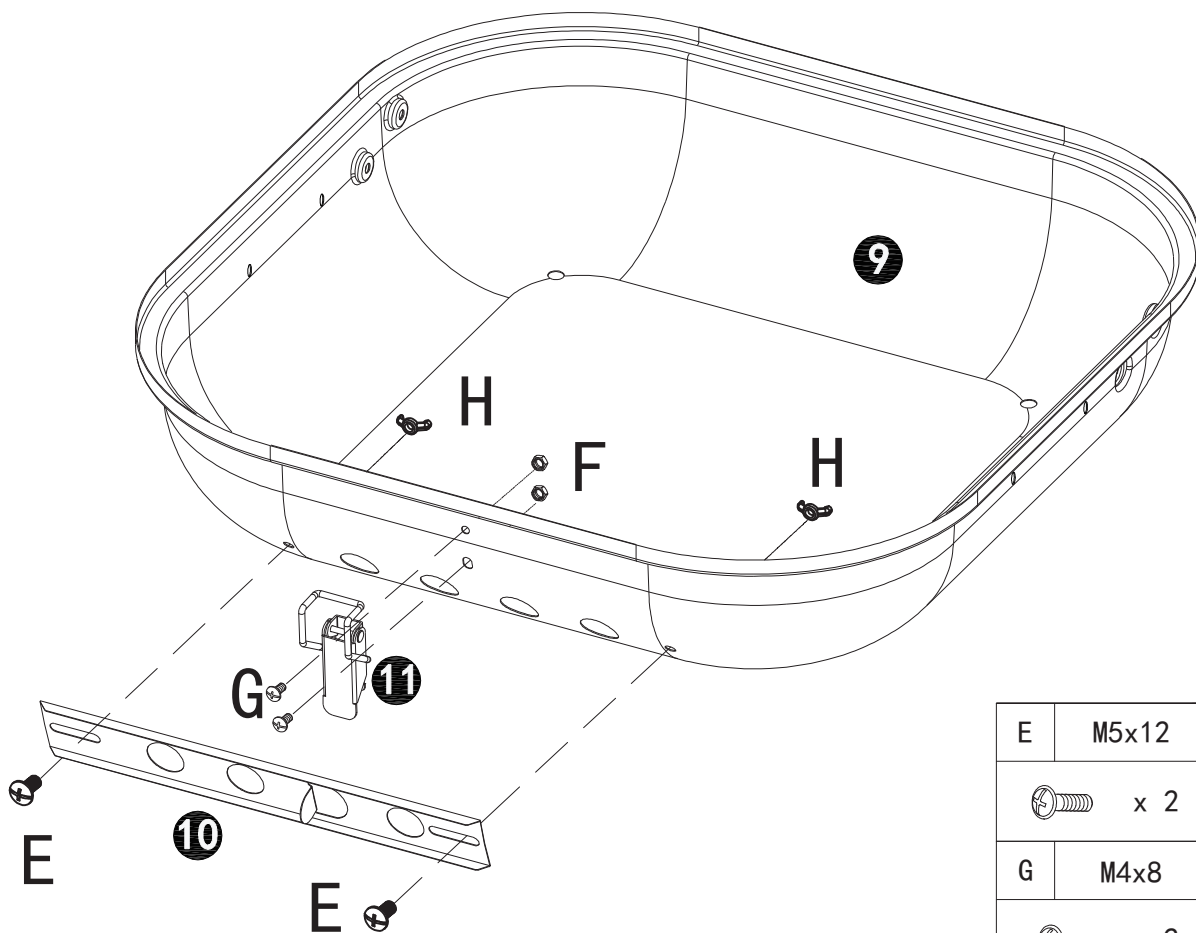



E	M5x12	H	M5	D	M6x12
	x 1		x 1		x 2



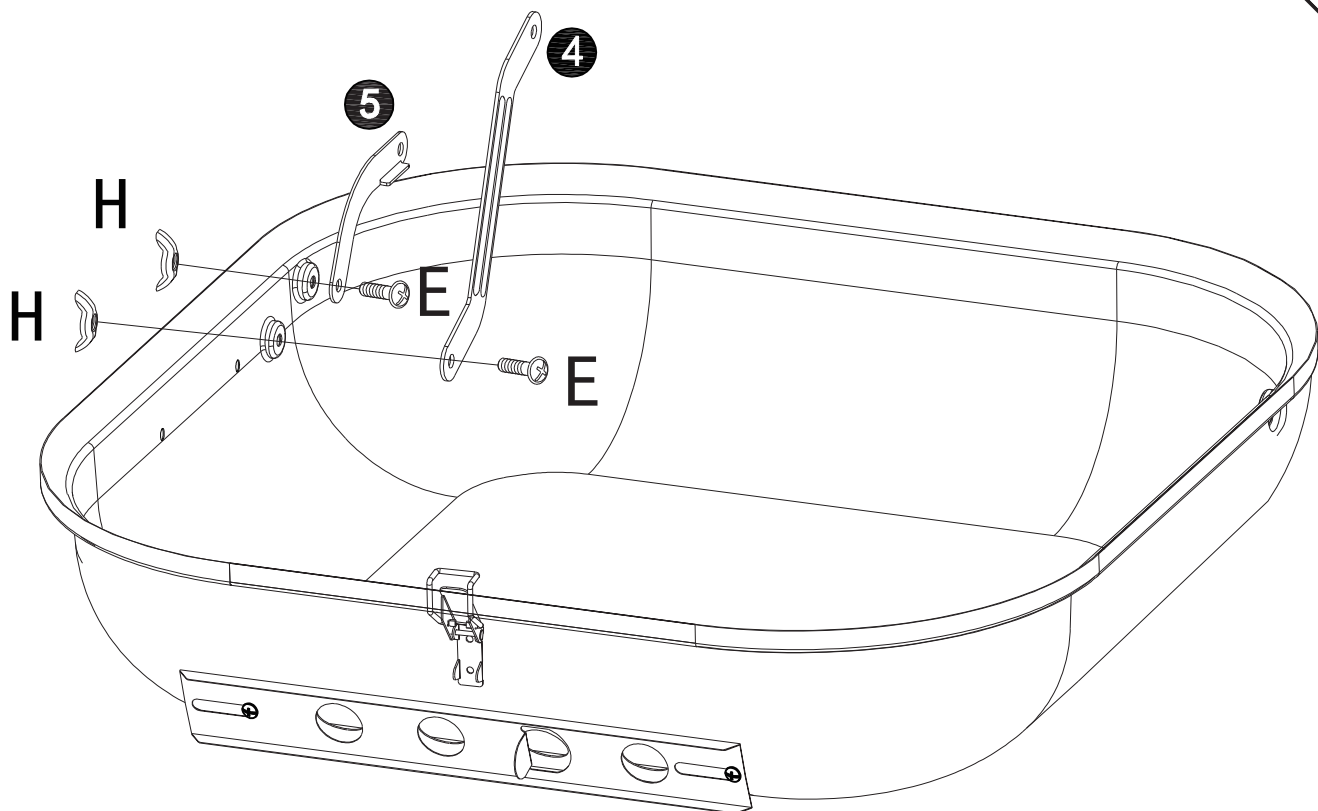

E	M5x12	H	M5
	x 2		x 2
G	M4x8	F	M4
	x 2		x 2



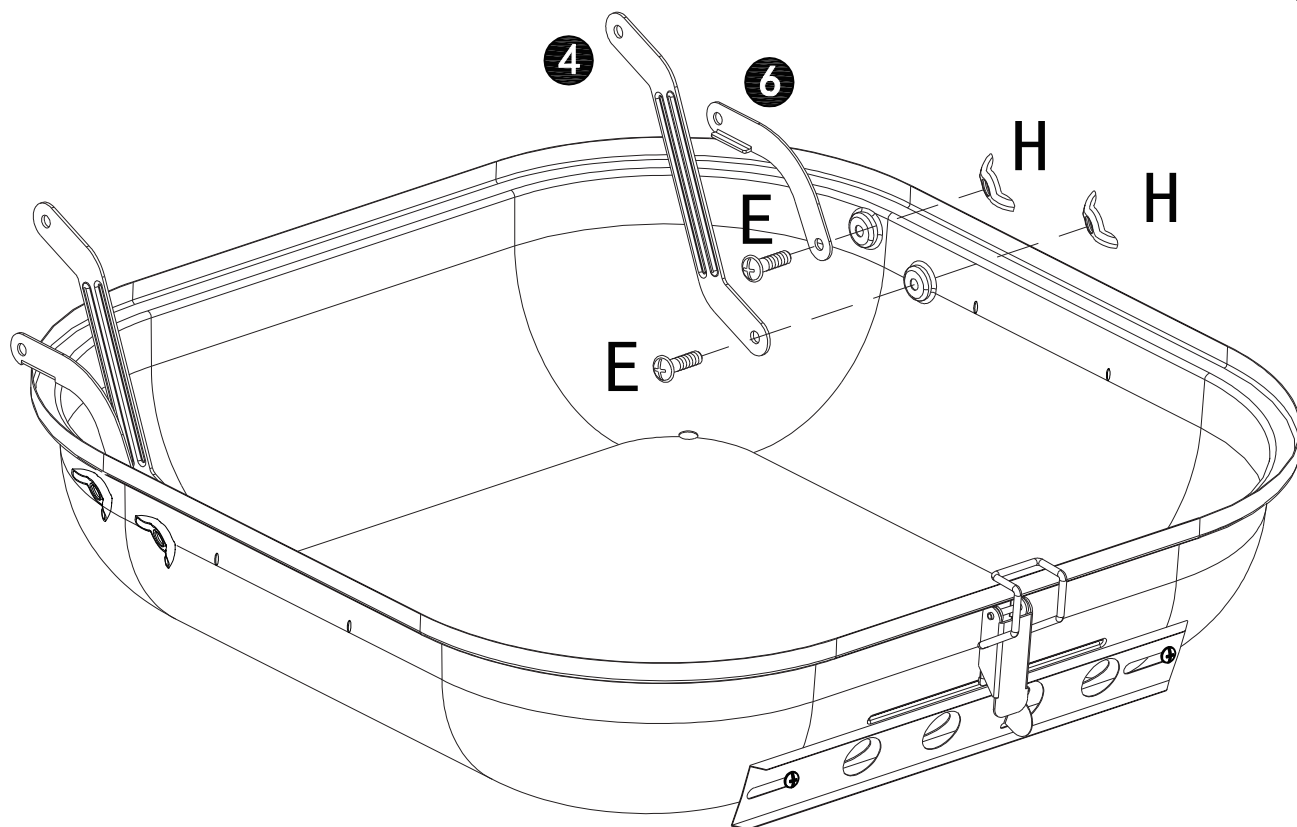

E	M5x12	H	M5
	x 2		x 2



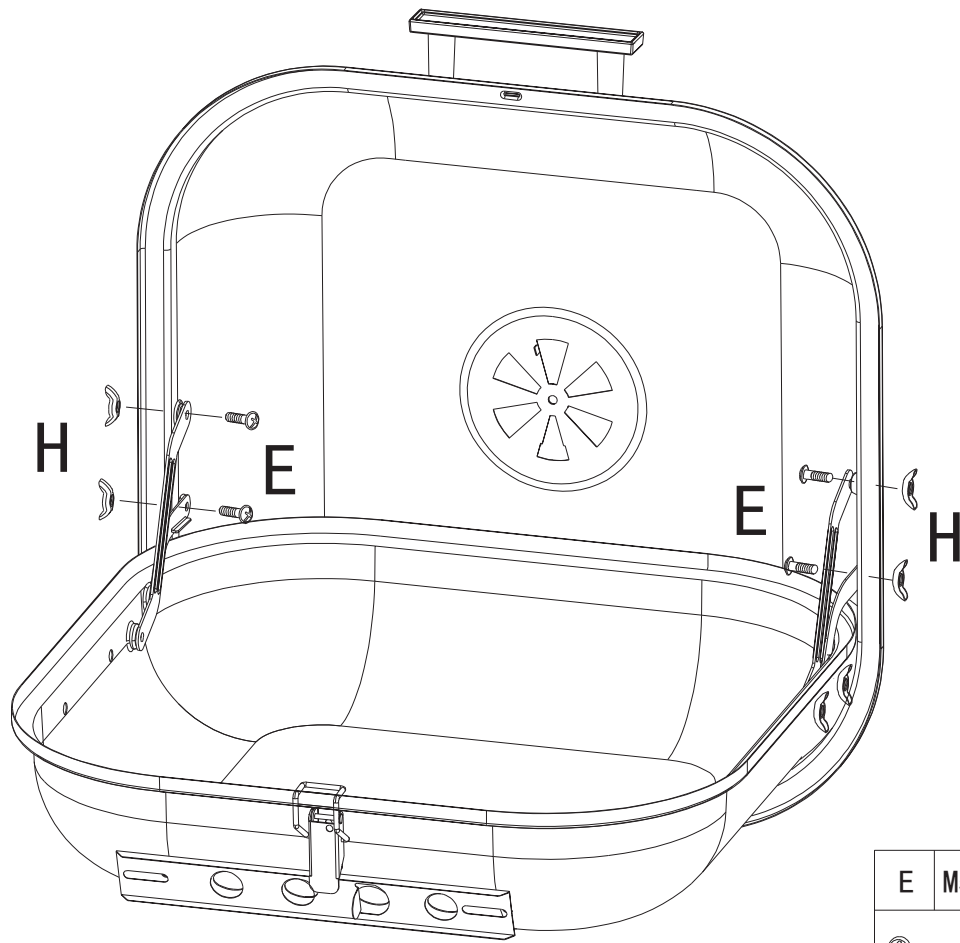

E	M5x12	H	M5
	x 2		x 2

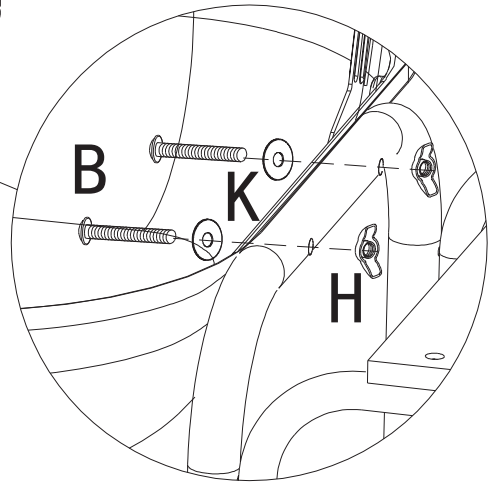
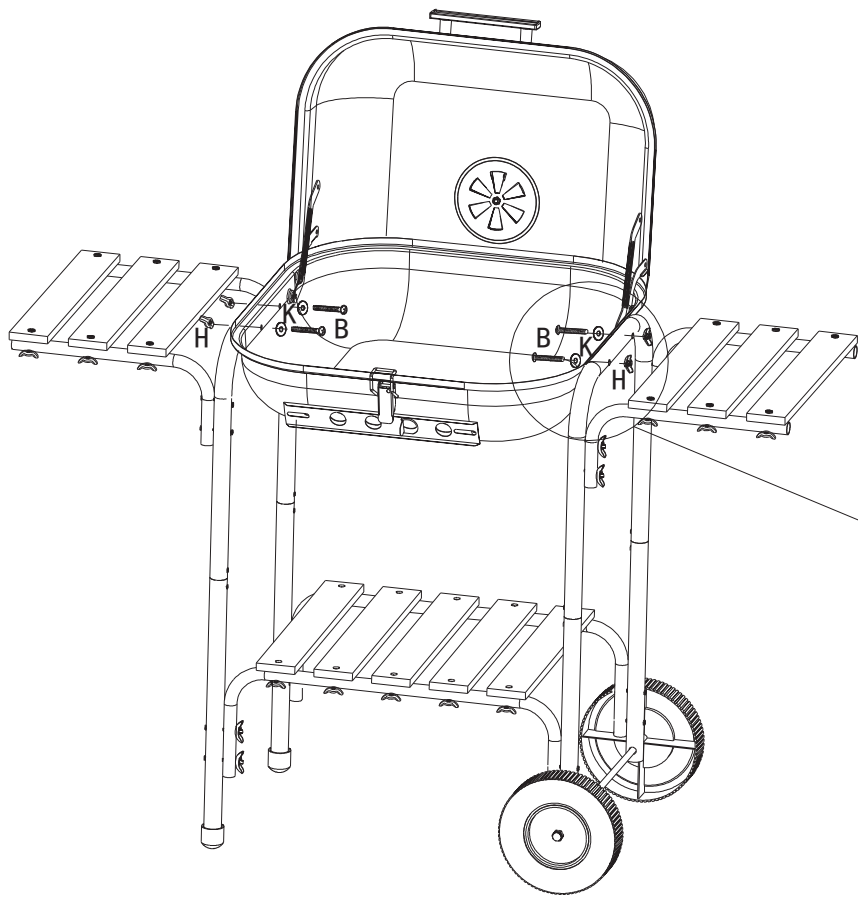

E	M5x12	H	M5
	x 4		x 4



B	M5x30	H	M5	K	∅6x18
	x 4		x 4		x 4

7

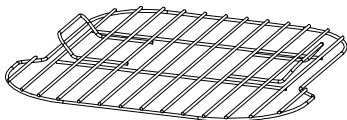

8

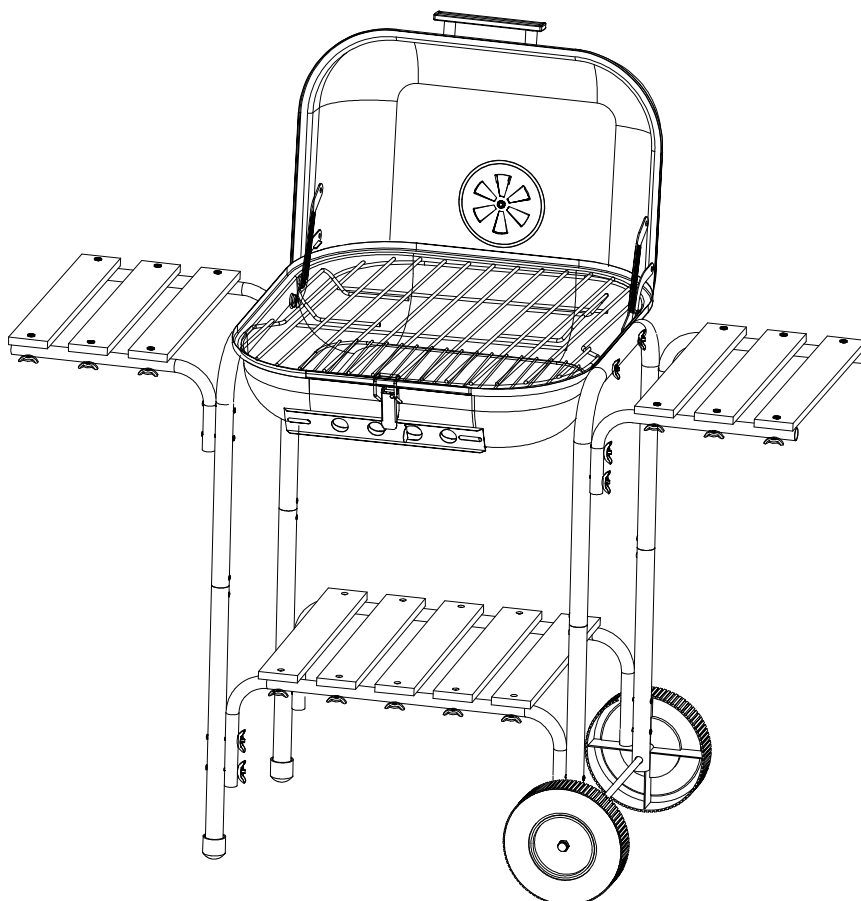
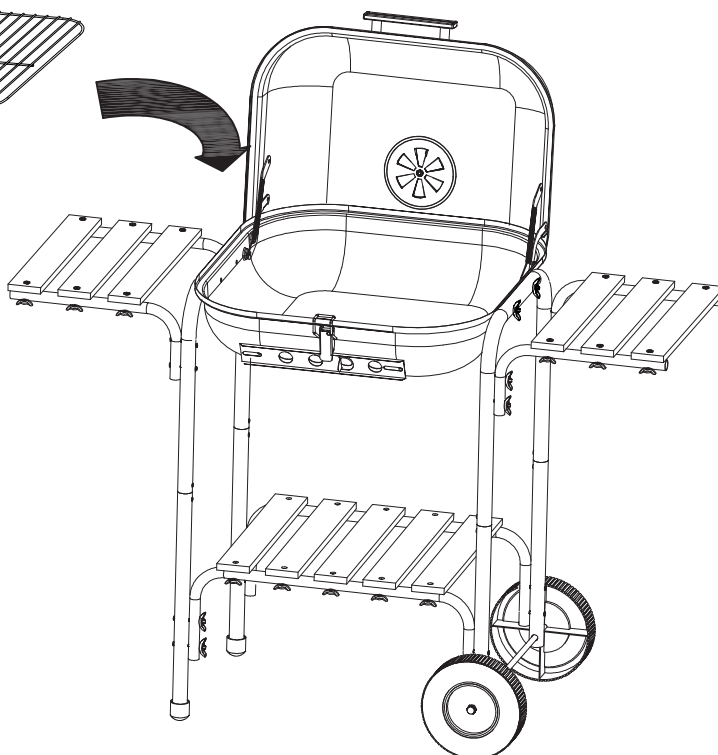



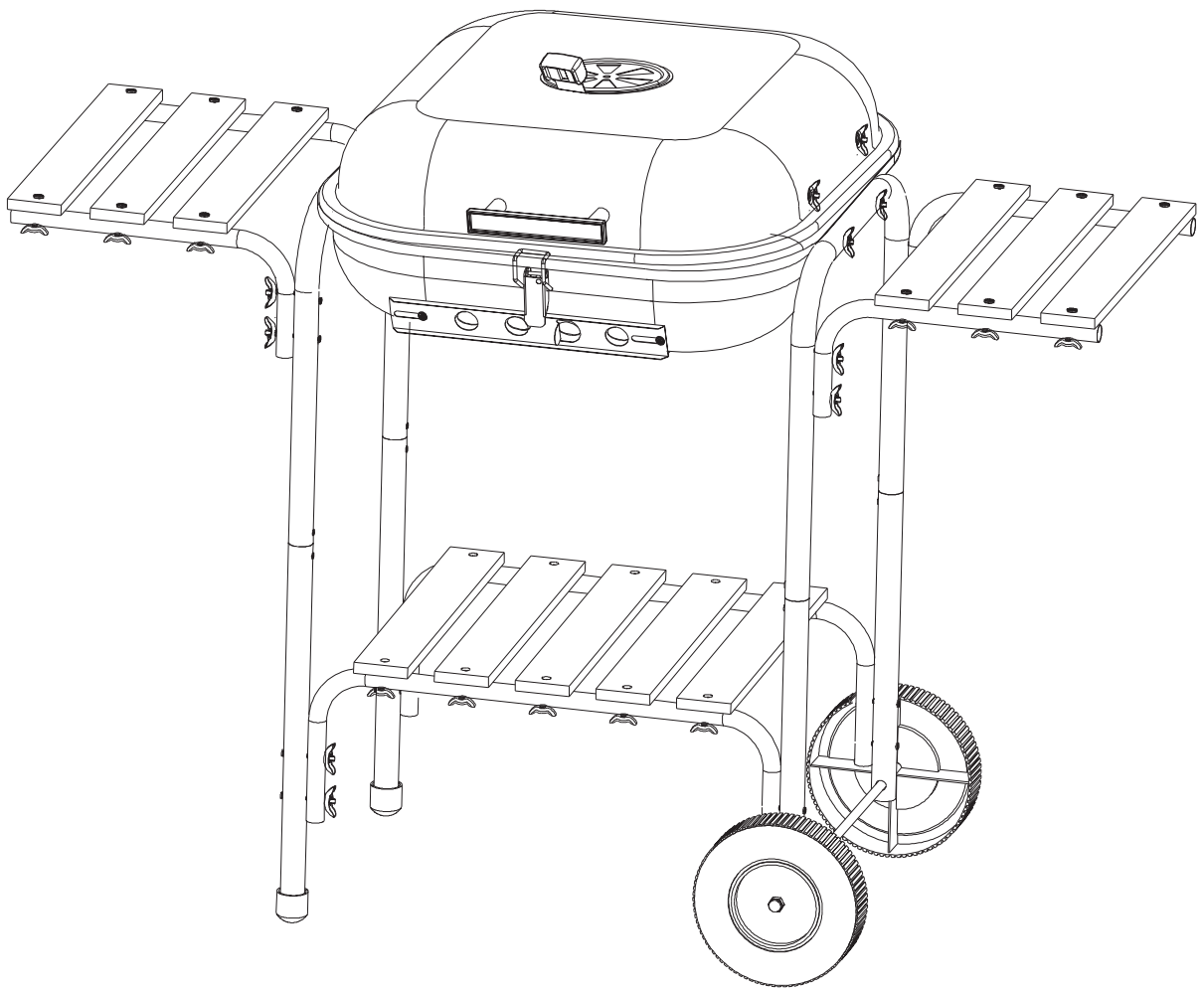

**UK**

If you have any questions, please contact our customer care center.

Our contact details are below:



0044-800-240-4004



enquiries@mhstar.co.uk

**IMPORTER ADDRESS:**

MH STAR UK LTD  
Unit 27, Perivale Park,  
Horsenden lane South  
Perivale, UB6 7RH  
MADE IN CHINA

**ES**

Si tiene alguna pregunta, comuníquese con nuestro Centro de Atención al Cliente. Nuestros datos de contacto son los siguientes:



0034-931294512



atencioncliente@aosom.es

**IMPORTADOR:**

SPANISH AOSOM, S.L.  
C/ ROC GROS, N° 15. 08550, ELS HOSTALETS DE  
BALENYÀ, SPAIN.  
B66295775  
WWW.AOSOM.ES  
ATENCIONCLIENTE@AOSOM.ES  
TEL: 931294512  
HECHO EN CHINA

**FR**

Si vous avez la moindre question, veuillez contacter notre centre d'assistance à la clientèle.

Nos coordonnées sont les suivantes:



0033-1-84166106



aosom@mhfrance.fr

**Importé par:**

MH France  
2, rue Maurice Hartmann  
92130 Issy-les-Moulineaux  
France  
Fabriqué en Chine

**IT**

In caso di dubbio, si prega di contattare il nostro centro assistenza clienti. I nostri dettagli di contatto sono di seguito:



0039-0249471447



clienti@aosom.it

**IMPORTATO DA:**

AOSOM Italy srl  
Centro Direzionale Milanofiori  
Strada 1 Palazzo F1  
20057 Assago (MI)  
P.I.: 08567220960  
FATTO IN CINA

**DE**

Wenn Sie Fragen haben, wenden Sie sich bitte an unser Kundendienstzentrum.

Unsere Kontaktdaten stehen unten:



0049-0(40)-88307530



service@aosom.de

**ADRESSE DES IMPORTEURE:**

MH Handel GmbH  
Wendenstraße 309  
D-20537 Hamburg  
Germany  
IN CHINA HERGESTELLT