**EN: ASSEMBLY INSTRUCTION**

FR: INSTRUCTIONS D'ASSEMBLAGE

ES: INSTRUCCIONES DE MONTAJE

DE: MONTAGEANLEITUNG

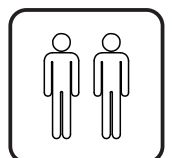

EN: IMPORTANT, RETAIN FOR FUTURE REFERENCE: READ CAREFULLY.

FR: IMPORTANT : A LIRE ATTENTIVEMENT ET À CONSERVER POUR CONSULTATION ULTÉRIEURE.

ES: IMPORTANTE, LEA DETENIDAMENTE Y GUARDE PARA FUTURAS REFERENCIAS.

DE: „WICHTIG! SORGFÄLTIG LESEN UND FÜR SPÄTER NACHSCHLAGEN AUFBEWAHREN.“

① x 1

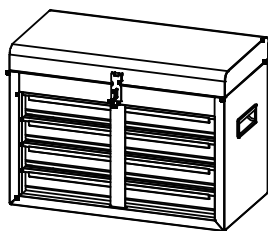

② x 1

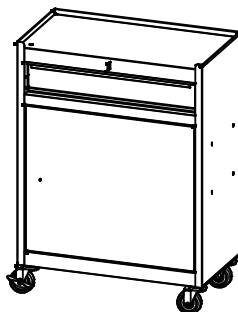

③ x 3

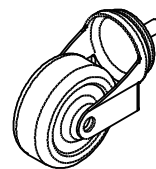

④ x 1

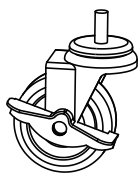

⑤ x 1

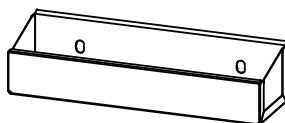

⑥ x 1

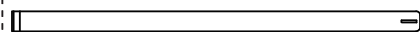

⑦ x 1

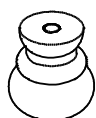

⑧ x 1

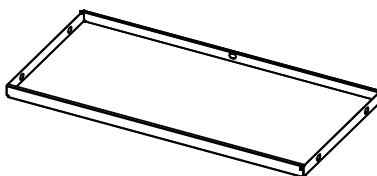

⑨ x 3

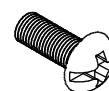

M6*9

⑩ x 1

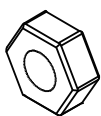

M6

⑪ x 1



M4*6

⑫ x 1



M6

⑬ x 1



⑭ x 1

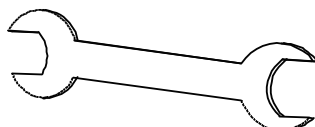

⑮ x 4



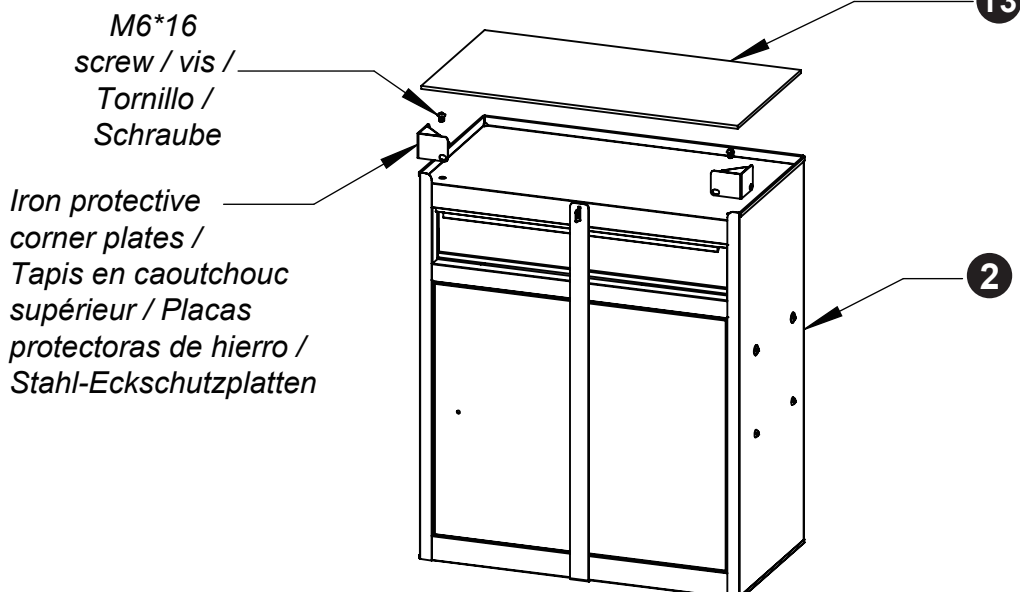

- EN** 1. Open the carton box and take out the tool cabinet, should be carefully, remove the 2 iron protective corner plates using the screwdriver.
- FR** 1. Pour commencer, ouvrez le carton et sortez l'armoire à outils, retirez avec précaution les deux planches d'angle de protection en fer à l'aide d'un tournevis.
- ES** 1. Abra la caja de cartón y saque el gabinete de herramientas, hágalo con cuidado, utilice el destornillador para retirar las 2 placas protectoras de hierro de las esquinas.
- DE** 1. Öffnen Sie den Karton und nehmen Sie den Werkzeugschrank heraus. Entfernen Sie vorsichtig die 2 Stahl-Eckschutzplatten mit einem Schraubenzieher.

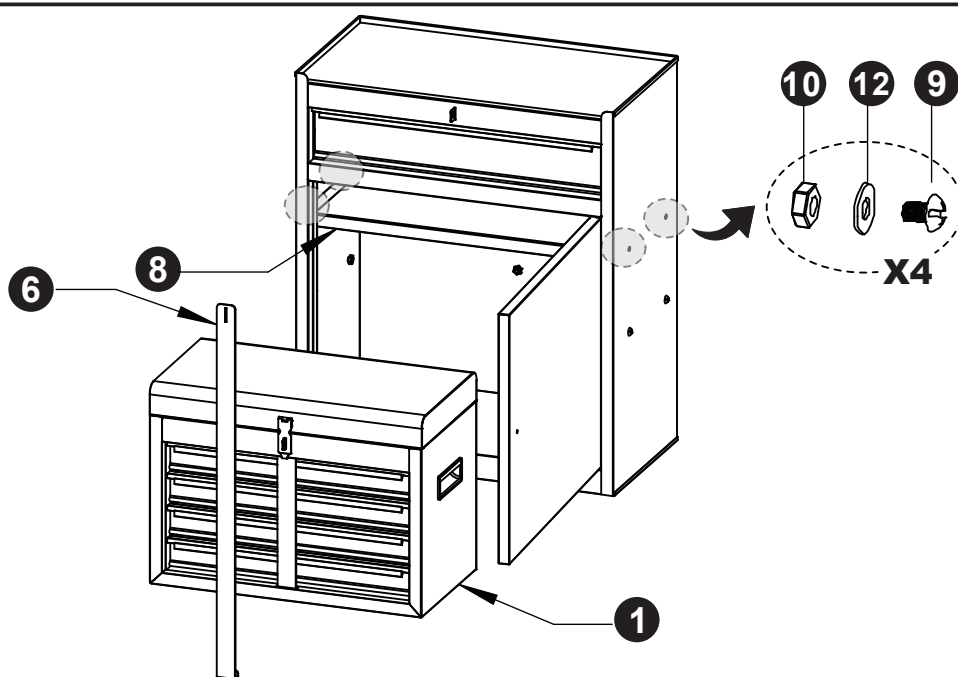

- EN** 2. Remove the lock bar then open the cabinet door, remove the 4 pieces screw in the inner middle tray, then take out the top chest from cabinet.
- FR** 2. Retirez la barre de verrouillage, puis ouvrez la porte de l'armoire, retirez les 4 vis du support central intérieur, puis sortez le coffre supérieur de l'armoire.
- ES** 2. Retire la barra de bloqueo, luego abra la puerta del gabinete, retire los 4 tornillos en la bandeja intermedia interna, entonces saque el cofre superior del gabinete.
- DE** 2. Entfernen Sie den Riegel, öffnen Sie die Schranktür, entfernen Sie die 4 Schrauben in der inneren Mittelablage, dann nehmen Sie den Werkzeugkasten aus dem Schrank.

accessory box / Boîte à accessoires / Caja de accesorios / Zubehörkasten

drawer / Tiroir /
Cajón / Schublade

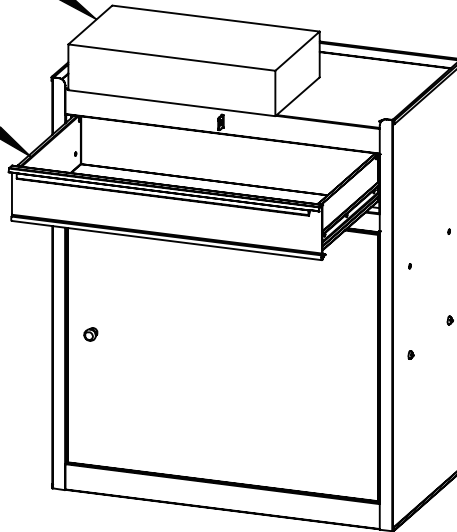

- EN 3. Take out the accessory box and parts box from the drawer of cabinet.
- FR 3. Sortez la boîte à accessoires et la boîte à pièces du tiroir de l'armoire.
- ES 3. Tercero: Saque la caja de accesorios y la caja de piezas del cajón del gabinete.
- DE 3. Nehmen Sie den Zubehörkasten und den Teilekasten aus der Schublade des Schrankes heraus.

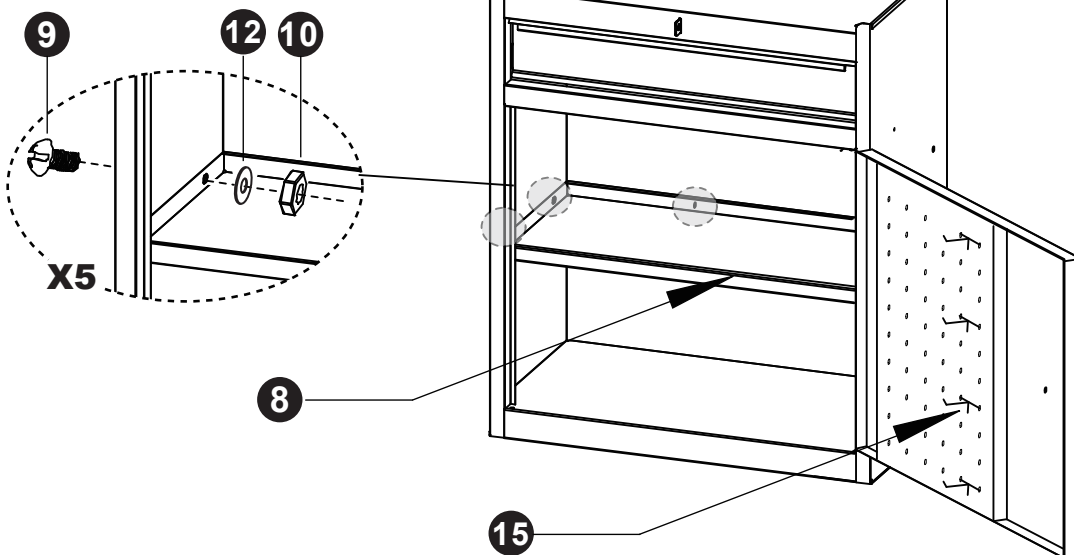

- EN 4. Using 5 pieces M6*9 screw to fix the inner middle tray on the second floor screw holes of the below cabinet.
- FR 4. Utilisez 5 vis M6*9 pour fixer le support central intérieur sur les trous de vis du deuxième étage du placard inférieur.
- ES 4. Utilice los 5 tornillos M6*9 para fijar la bandeja intermedia interna a los orificios para tornillos que están en el segundo piso del gabinete inferior.
- DE 4. Verwenden Sie 5 Stück M6 x 9-Schrauben, um die innere Mittelablage an den Schraublöchern des zweiten Bodens des unteren Schrankes zu befestigen.

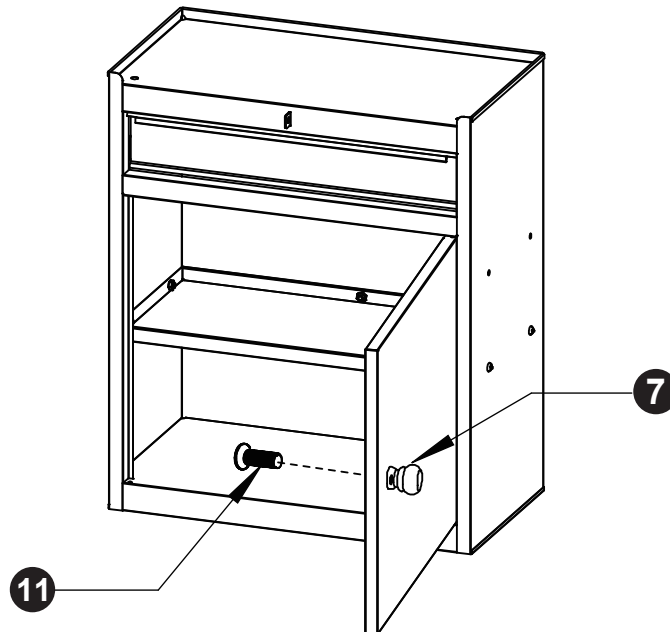

EN 5. Take out the handle of the door, assemble it using 1 piece M4*6 screw.

FR 5. Sortez la poignée de la porte et assemblez-la à l'aide d'une vis M4*6.

ES 5. Saque la manija de la puerta, utilice 1 tornillo M4 * 6 para fijarla en su lugar.

DE 5. Nehmen Sie den Türgriff heraus und montieren Sie ihn mit 1 Stück M4 x 6 Schraube.

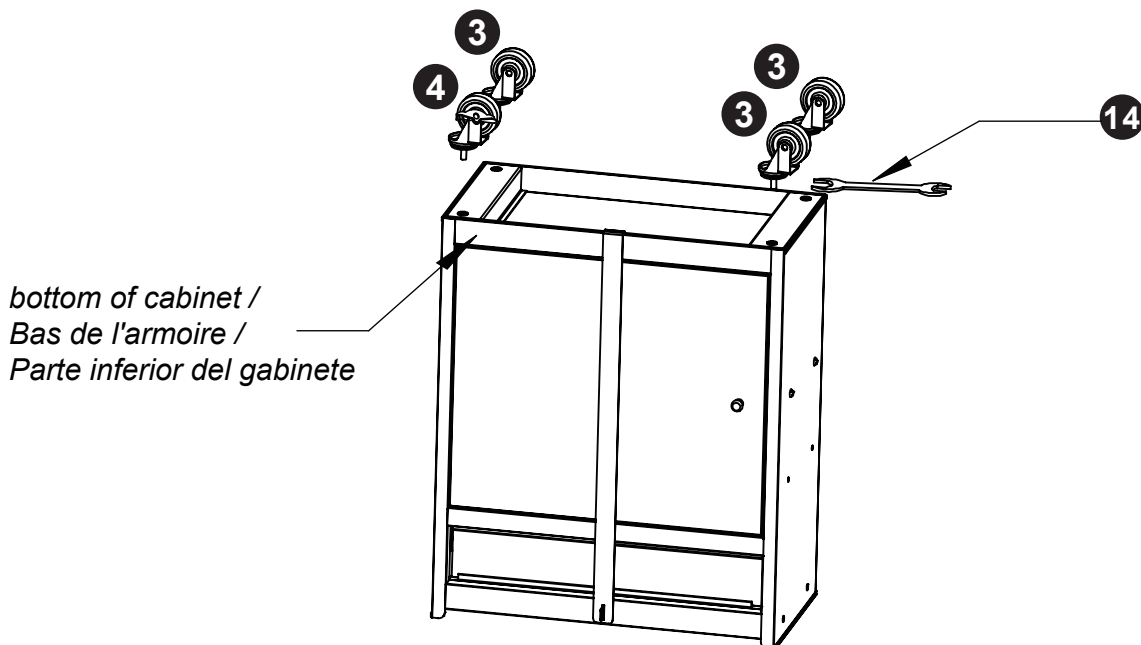

EN 6. Assemble the casters on the bottom of the cabinet, then tighten with the wrench.

FR 6. Assemblez les roulettes au bas de l'armoire, puis serrez-les avec la clé.

ES 6. Monte las ruedas en la parte inferior del gabinete, luego apriételas con la llave.

DE 6. Montieren Sie die Laufräder an der Unterseite des Schrankes und ziehen Sie sie mit dem Schraubenschlüssel fest.

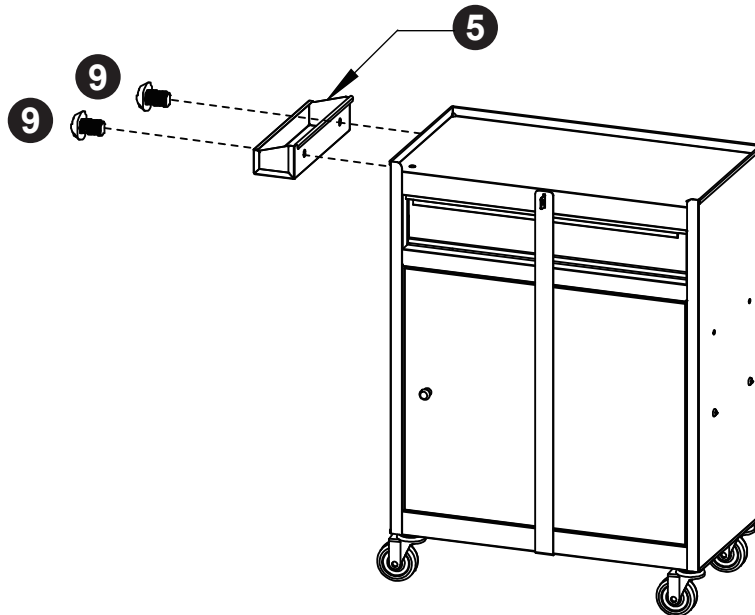

EN 7. Assemble the parts box on the cabinet side using 2 pieces M6*9 screws.

FR 7. Assemblez la boîte à pièces sur le côté de l'armoire à l'aide de 2 vis M6*9.

ES 7. Utilice 2 tornillos M6 * 9 para fijar la caja de piezas en el costado del gabinete adecuadamente.

DE 7. Montieren Sie den Teilekasten an der Schrankseite mit 2 Stück M6 x 9 Schrauben.

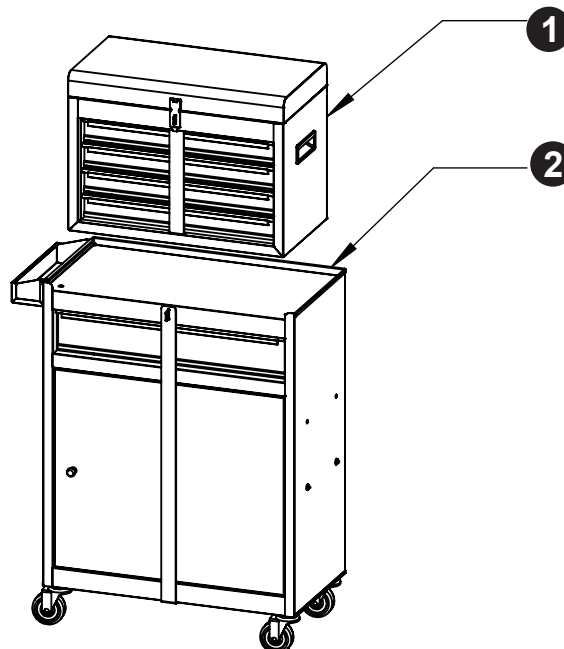

EN 8. Put the top chest on the cabinet, then can use it normally.

FR 8. Placez le coffre supérieur sur l'armoire, vous pouvez alors l'utiliser normalement.

ES 8. Coloque el cofre superior en el gabinete, luego ya puede utilizarlo normalmente.

DE 8. Setzen Sie den oberen Werkzeugkasten auf den Schrank, dann können Sie ihn normal benutzen.

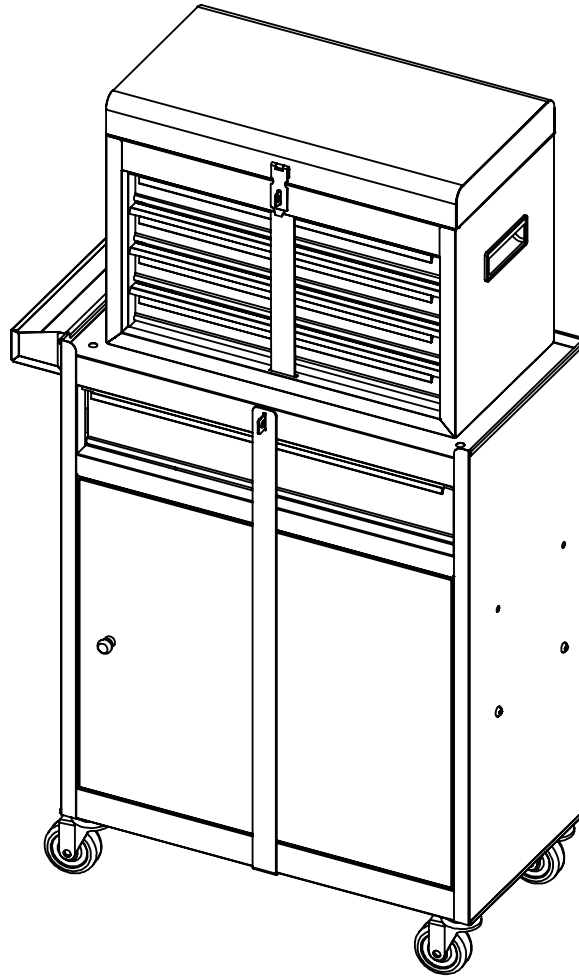

EN Finish assemble, please feel free to use.

FR L'assemblage est terminé, vous pouvez maintenant utiliser votre produit.

ES El montaje está completo, puede utilizarlo con confianza.

DE Beenden Sie den Zusammenbau und benutzen Sie sie einfach.

UK

If you have any questions, please contact our customer care center.

Our contact details are below:



0044-800-240-4004



enquiries@mhstar.co.uk

IMPORTER ADDRESS:

MH STAR UK LTD

Unit 27, Perivale Park,
Horsenden lane South

Perivale, UB6 7RH

MADE IN CHINA

ES

Si tiene alguna pregunta, comuníquese con nuestro Centro de Atención al Cliente.

Nuestros datos de contacto son los siguientes:



0034-931294512



atencioncliente@aosom.es

IMPORTADOR:

SPANISH AOSOM, S.L.

C/ ROC GROS, N° 15. 08550, ELS HOSTALETES DE
BALENYÀ, SPAIN.

B66295775

WWW.AOSOM.ES

ATENCIONCLIENTE@AOSOM.ES

TEL: 931294512

HECHO EN CHINA

CA

If you have any questions, please contact our customer care center.

Our contact details are below:

Si vous avez la moindre question, veuillez contacter notre centre d'assistance à la clientèle.

Nos coordonnées sont les suivantes:



416-792-6088



customerservice@aosom.ca

Imported by Aosom Canada Inc.

7270 Woodbine Avenue, Unit 307, Markham, Ontario Canada L3R 4B9

MADE IN CHINA

Importé par Aosom Canada Inc.

7270 Woodbine Avenue, unité 307, Markham, Ontario Canada L3R 4B9

Fabriqué en Chine

DE

Wenn Sie Fragen haben, wenden Sie sich bitte an unser Kundendienstzentrum.

Unsere Kontaktdaten stehen unten:



0049-0(40)-88307530



service@aosom.de

ADRESSE DES IMPORTEUR:

MH Handel GmbH

Wendenstraße 309

D-20537 Hamburg

Germany

IN CHINA HERGESTELLT