

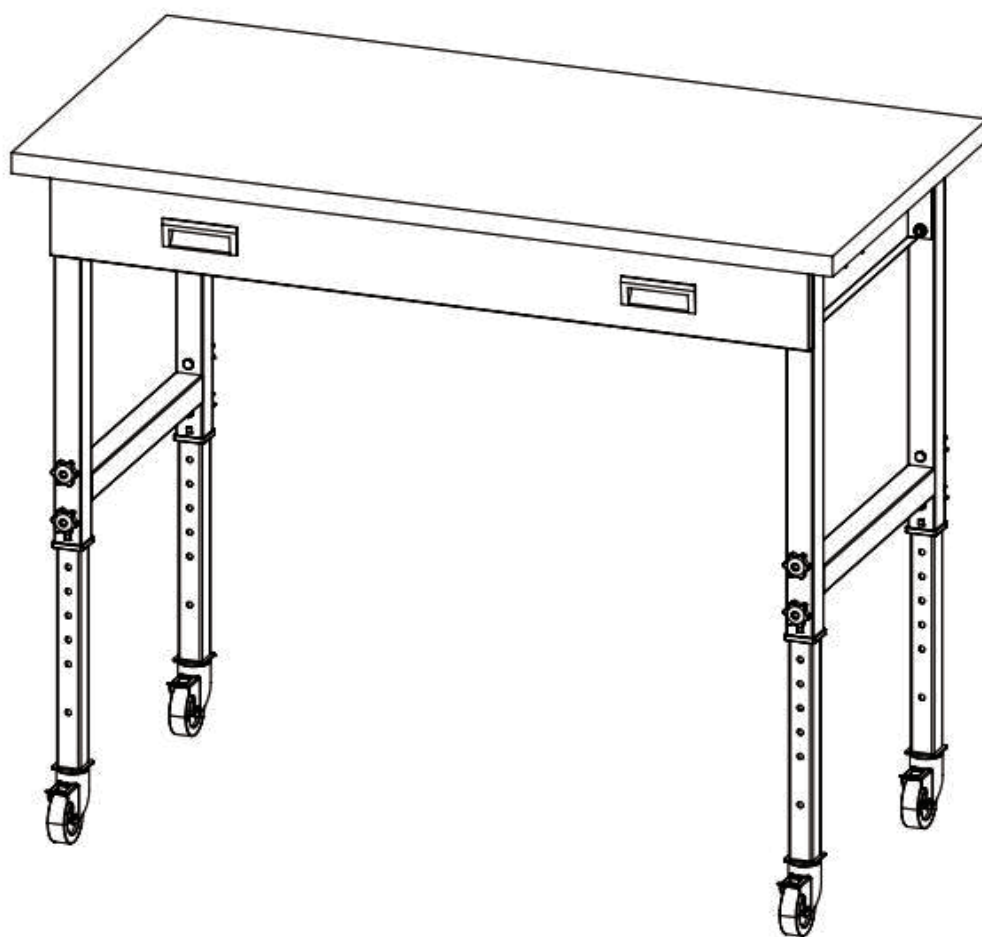

IN230600013V01\_US

**B71-046\_B71-046V01**



IMPORTANT, RETAIN FOR FUTURE REFERENCE: READ CAREFULLY

**ASSEMBLY INSTRUCTION**

Warning: The manual contains very important safety information, please read it carefully before assembling and keep it safe for future reference.



- 1) Carefully check the box for any damages. If damaged, please take a photo for your record and contact our service team for help.
- 2) The workbench can be dangerous if it is not installed correctly. Fasten all screws, nuts before using it.
- 3) Use safety goggles to install the workbench.
- 4) When using the workbench, ensure all casters are locked to avoid any mishaps. Unlocked casters can be very dangerous.
- 5) Keep away from children. This is not a toy and children should not be allowed to play on it.
- 6) Keep workbench away from water and moisture.
- 7) Please do not discard the box until after you have finished assembling the workbench.

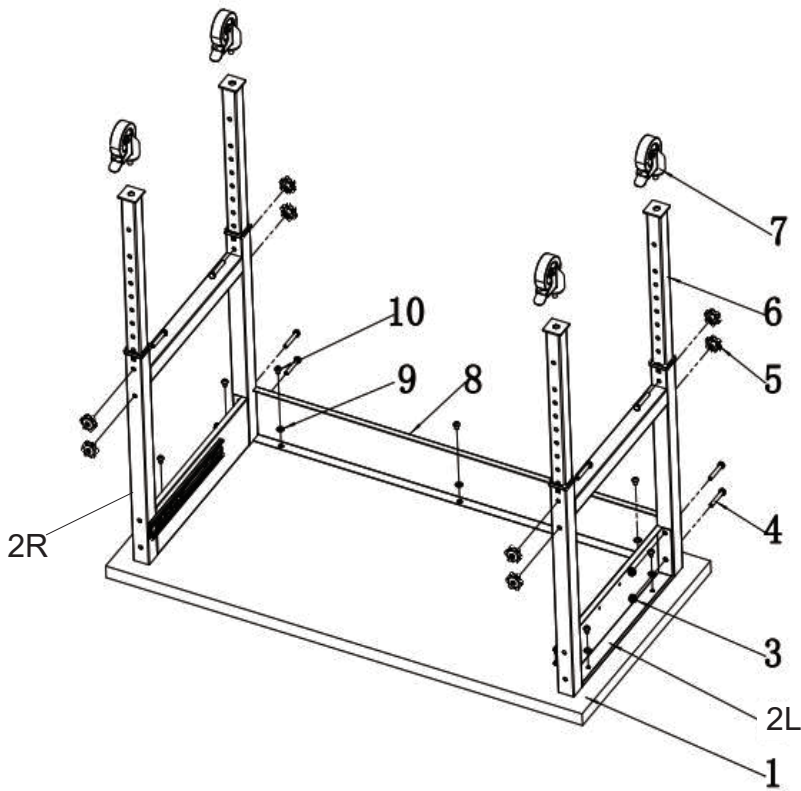

	Description	QTY
1	Wood Board	1
2L	Leg	1
2R	Leg	1
3	M8 Nut	4
4	M8 x 50 Screw	12
5	M8 Big Plastic Nut	8
6	Leg Extend	4
7	Caster	4
8	Support	1
9	M8 Gasket	7
10	M8x16 Screw	7

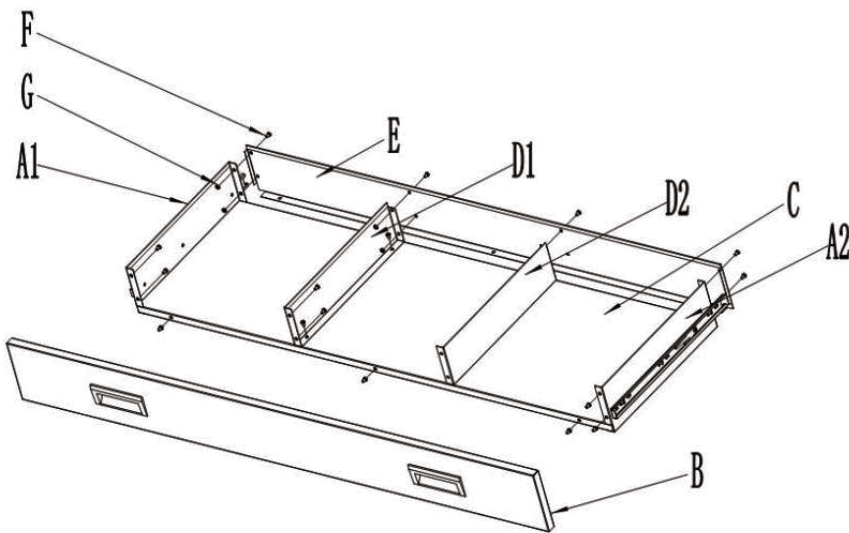

	Description	QTY
A1	Drawer Left Panel	1
A2	Drawer Right Panel	1
B	Drawer Front Panel	1
C	Drawer Bottom Panel	1
D1	Drawer Left Partition	1
D2	Drawer Right Partition	1
E	Drawer Behind Panel	1
F	M4x6 Screw	30
G	M4 Nut	8

Tips:

- 1) Do not fasten all screws and nuts tightly, you may need to rework if you make a mistake.
- 2) We recommend 2 adults are required to complete the installation.

1. Fasten legs to the wood board.

A) Place the wood board on a clean surface (floor). To protect the wood board, we recommend you to use a soft cloth or box on the floor.

B) Please make sure the mounting holes are aligned with the holes in the board, and that the leg are symmetrical

C) Use 4pcs M8x16 screws and 4pcs gasket to fasten 2 legs to wood board.

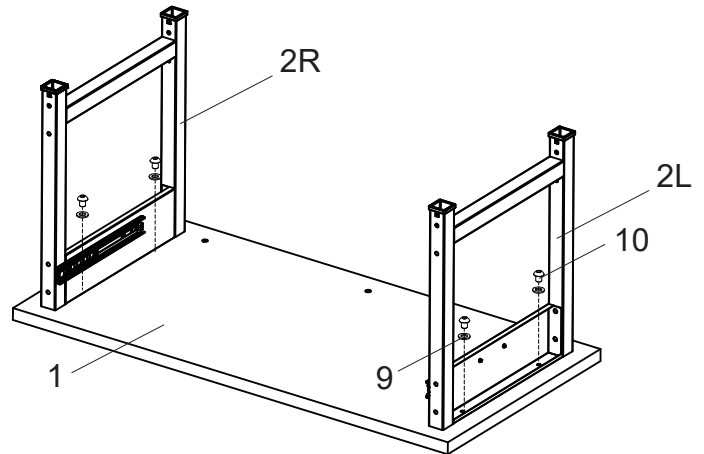

2. Fasten support to wood board and legs

A) Fasten support to leg, use 4pcs M8x50 screws and nuts

B) Fasten support to wood board, use 3pcs M8x16 screws and 3pcs M8 gasket

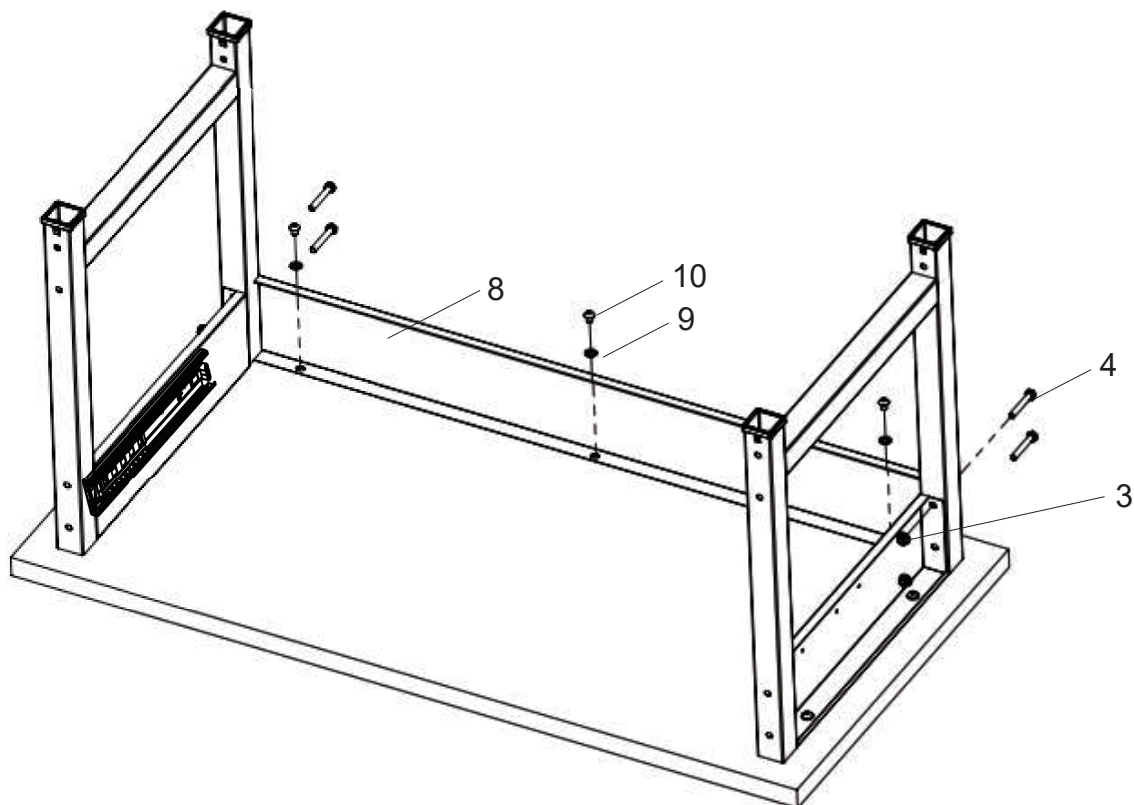

3. Fasten leg extensions to legs and adjust to same height.

Use 8pcs M8x50 screws and 8pcs M8 Big plastic nuts to fasten them.

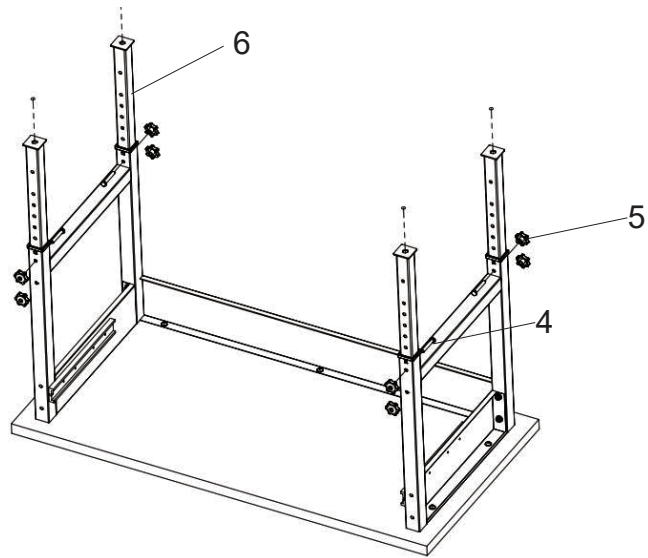

4. Install casters on leg extend·

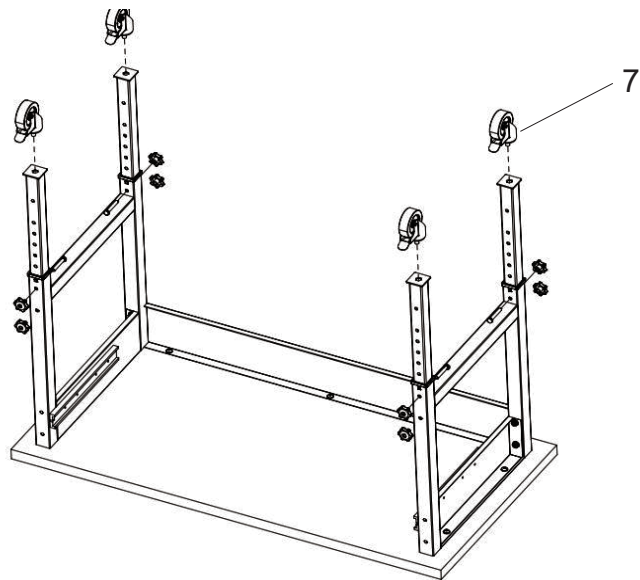

5. Tighten all bolts and nuts, reverse the workbench.

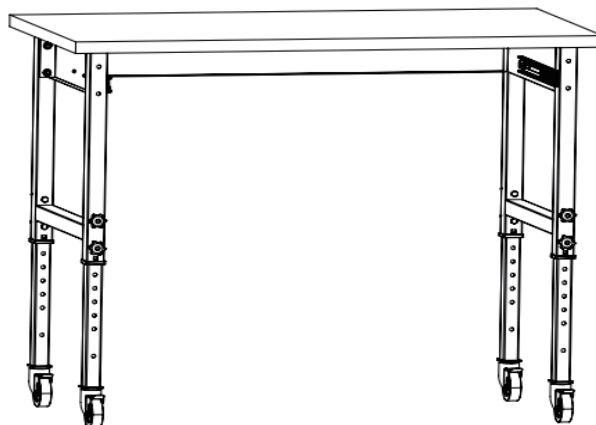

## 6. Assemble the drawer

- ① As the below picture, using M4X6 screw and M4 nut to fix A1, A2, D1, D2 to C
- ② As the below picture, using M4X6 screw to fix B to C
- ③ As the below picture, using M4X6 screw and M4 nut to fix E to C

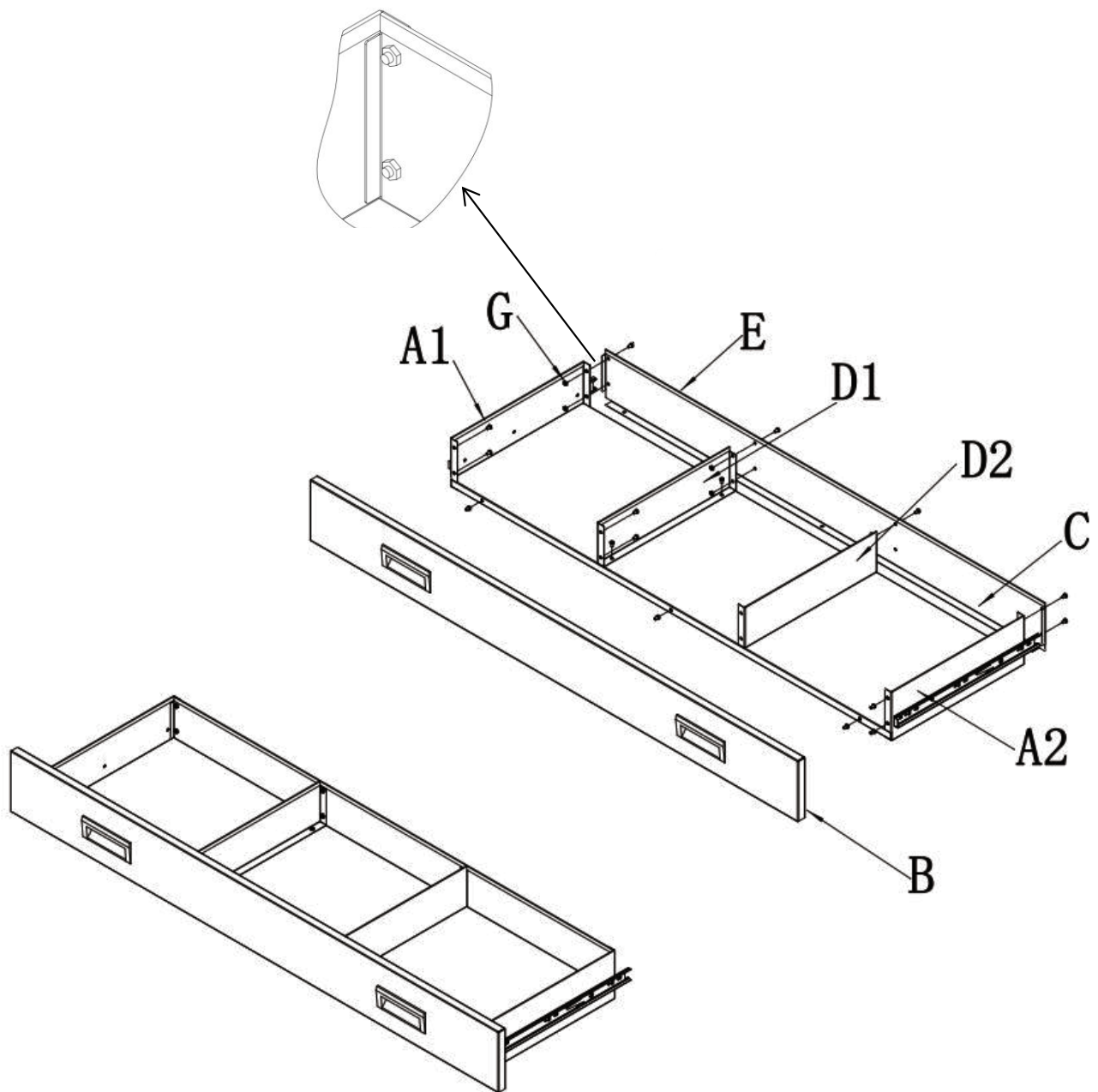

7. Tighten all screws and nuts, installed the drawer to workbench, then Finish.

For workbench with drawer, the side board and rail was pre-installed at the production factory

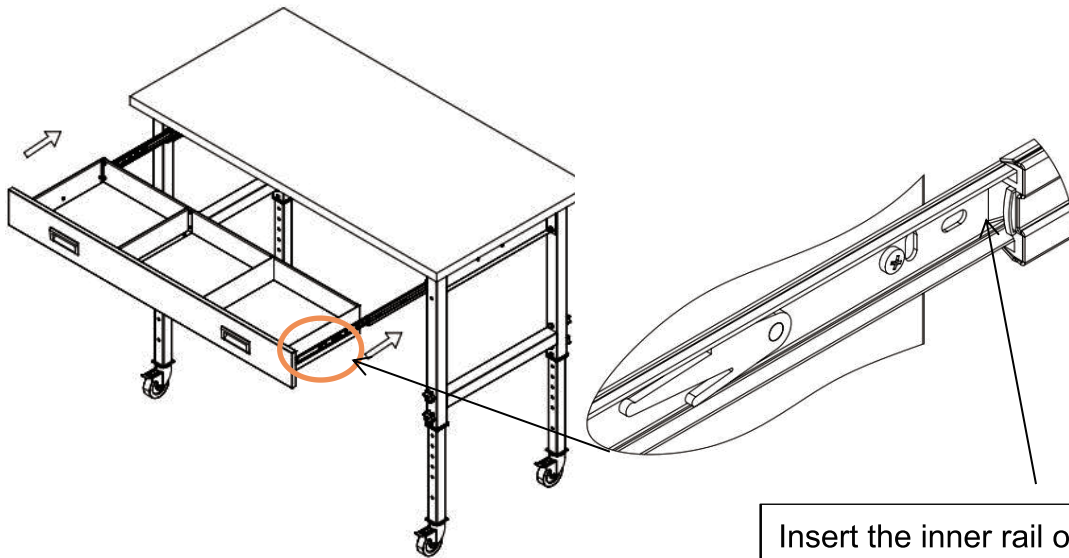

Insert the inner rail on the drawer to the outer rail, then parallel push it

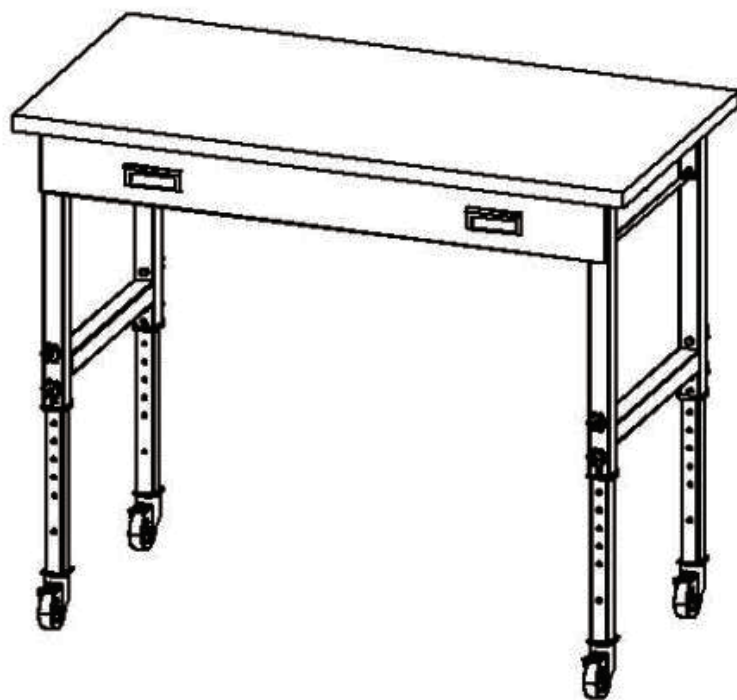

**WARNING:**

For workbench with drawer, pls make sure the drawer is correctly installed, do not place heavy tools or items inside, it may destroy the drawer.

If you have any questions, please contact our customer care center.  
Our contact details are below:

 001-877-644-9366

 [customerservice@aosom.com](mailto:customerservice@aosom.com)

Imported by Aosom LLC  
27150 SW Kinsman Rd Wilsonville, OR 97070 USA  
MADE IN CHINA