



IN230600152V01_IT

A91-234V00

STAZIONE FITNESS MULTIFUNZIONE

IT

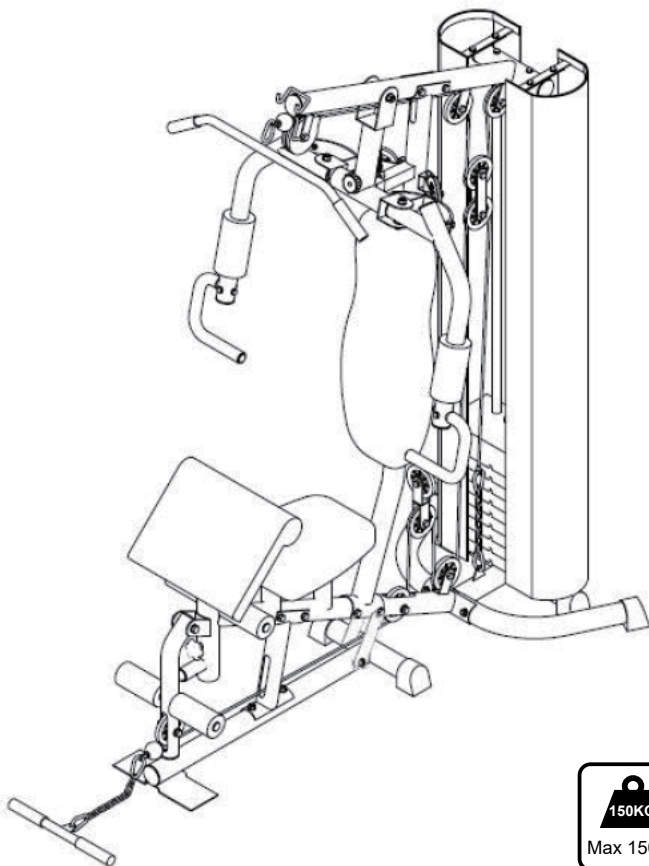

IMPORTANTE, LEGGERE E CONSERVARE QUESTO MANUALE D'ISTRUZIONE PER UN USO FUTURO.









ISTRUZIONI DI ASSEMBLAGGIO











PACKING DETAILS: TOTAL 4 BOXES

BOX-1/4

Scatola degli accessori

Scatola degli accessori







NO.	Description	Qtà
1	Telaio di base 	1
3	Stabilizzatore posteriore 	1
4	Tubo di supporto del sedile 	1
5	Tubo di supporto verticale 	1
7	Tubo guida 	2
9	Unità per tirare 	1
59	Cuscino schienale 	1
60	Sedile 	1
75	Copertura in tessuto per sinistra/destra 	2

NO.	Description	Qtà
49	Puleggia 	11
49A	Puleggia A 	1
50	Tappo per Puleggia Piccola 	2
65	Cavo per barra laterale 	1
66	Cavo per braccio a farfalla 	1
67	Cavo per barra di trazione inferiore 	1
13	Barra di trazione inferiore 	1
11	Manubrio 	2
55	Schiuma per manubrio 	2
15	Staffa per sedile/schienale 	2

NO.	Description	Qtà
17	Staffa per Puleggia 	2
18	Staffa a due vie per puleggia 	1
20	Staffa puleggia 	2
78	Cinghia di collegamento 	2
48	Anello di gomma 	2
57	Tappo rotondo per barra di selezione 	1
71	Manopola 	1

PACKING DETAILS: TOTAL 4 BOXES



BOX-2/4

NO	Description	Image	Qtà
10L/R	Braccio a farfalla- Sinistro/Destra		2
2	Reggisella		1
8	Tubo a ponte		1
12	barra laterale		1
53	Schiuma per braccio a farfalla		2
54	Schiuma per Leg Curl		4
72	Cuscino per gomiti		1
73	Staffa per la copertura in tessuto		4
6	Tubo per leg curl		1
68	Tubo di supporto per Cuscino		1
19	Barra Selezione		1
	hardware		2

BOX-3/4

NO.	Description	Image	Qtà
64	Piastra di pesi 10 libbre		5

BOX-4/4

NO.	Description	Image	Qtà
64	Piastra di pesi 10 libbre		4
63	Piastra di pesi 8 libbre		1

Introduzione	3
Sicurezza & Avvertenz	7
Panoramica	8
Assemblaggio	11



MESSAGGIO IMPORTANTE
ATTENZIONE - SI PREGA DI LEGGERE

RICHIESTO L'ASSEMBLAGGIO DA ADULTI
RISCHIO DI SOFFOCAMENTO Parti di piccole dimensioni.
NON per bambini sotto i 3 anni di età.

AVVERTIMENTO:

Sebbene venga fatto ogni tentativo per garantire il massimo livello di protezione a tutte le attrezzature, non possiamo garantire di non incorrere in lesioni. L'utente si assume tutti i rischi di incorrere in lesioni dovuti all'uso. Tutta la nostra merce viene venduta a queste condizioni, a cui nessun rappresentante dell'azienda può rinunciare o modificare.

INFORMAZIONI DI SICUREZZA

IMPORTANTE: leggere interamente prima del montaggio o dell'uso.

Questa attrezzatura sportiva è costruita per ottenere una sicurezza ottimale. Tuttavia, alcune precauzioni devono essere applicate ogni volta che si utilizza un'attrezzatura sportiva. Assicurarsi di leggere interamente il manuale prima di montare, mettere in funzione o utilizzare questa attrezzatura, e osservare le seguenti precauzioni di sicurezza.

Avvertenze per l'assemblaggio

- Assicurarsi di disporre di tutte le parti e gli utensili elencati.
- Rimuovere tutti i raccordi dai sacchetti di plastica e separarli nei rispettivi gruppi.
- Tenere bambini e animali domestici lontani dalle aree di lavoro, le parti di piccole dimensioni possono causare il soffocamento se ingerite.
- Assicurarsi di avere spazio sufficiente per disporre le parti prima di iniziare il montaggio.
- Il montaggio di questa attrezzatura viene eseguito al meglio da 2 persone insieme.
- Assemblare l'attrezzatura il più vicino possibile alla sua posizione finale (nella stessa stanza).
- L'attrezzatura indipendente deve essere installata su una base stabile e in piano.
- Smaltire tutti gli imballaggi con attenzione e responsabilità.

Avvertenze per l'uso

- Questa attrezzatura sportiva è realizzata per allenarsi in un ambiente privato. Utilizzare l'attrezzatura solo per l'uso previsto.
- **NON** apportare modifiche all'attrezzatura che possano comprometterne la sicurezza.
- **Avvertenza! Le persone incinte o con lesioni fisiche preesistenti non dovrebbero mai utilizzare l'attrezzatura sportiva senza previa consultazione con un medico di fiducia.**
- Siate consapevole dei segnali del vostro corpo. Un allenamento scorretto o eccessivo può danneggiare la vostra salute.
INTERROMPERE l'esercizio se si avverte dolore, senso di oppressione al petto, battito cardiaco irregolare, estrema mancanza di respiro, vertigini, o nausea. Se si verifica una di queste condizioni, **CONSULTARE IMMEDIATAMENTE IL MEDICO** prima di continuare con il programma di allenamento.
- Adattare sempre il vostro stile di allenamento al vostro livello di forma fisica e al vostro stato di salute.
- Prima di ogni sessione di allenamento, controllare il corretto funzionamento e la sicurezza dell'attrezzatura.
- Prima dell'uso, assicurarsi che l'attrezzatura sia installata correttamente e che tutti i dispositivi di sicurezza siano funzionanti! Danni o alterazioni al

prodotto risultanti da modifiche ne invalideranno la garanzia. Per problemi derivanti dalla modifica o da altre limitazioni, il venditore non è ritenuto responsabile.

- Eventuali danni devono essere segnalati al venditore immediatamente dopo la consegna e prima dell'uso o dell'installazione. I reclami pervenuti successivamente non verranno presi in considerazione.
- Utilizzare solo utensili adatti per il montaggio.
- L'installazione deve essere eseguita SOLO da adulti. I bambini non dovrebbero essere presenti nelle immediate vicinanze dell'area di lavoro in cui si svolgono le operazioni di assemblaggio.
- Assicurarvi che tutti i raccordi siano montati saldamente prima di lasciare che il prodotto venga utilizzato.
- Controllare tutti i raccordi a intervalli regolari per danni, componenti allentati e altri fattori che possono portare a un allentamento della sicurezza.
- Non lasciare i bambini incustoditi sulla panca pesi! Non è un giocattolo! Chiedere loro di non giocare o arrampicarsi sull'attrezzatura.
- In caso di guasto durante l'uso o durante la manutenzione, interrompere l'uso dell'attrezzatura per evitare qualsiasi rischio di lesioni.
- I bambini o le persone con capacità fisiche o mentali ridotte, o coloro che non hanno familiarità con questa attrezzatura, non dovrebbero essere autorizzati a usare questa panca pesi!
- Tenere presente che questo manuale e le precauzioni di sicurezza possono solo focalizzare la vostra attenzione su eventuali pericoli. Quando si maneggia questo dispositivo è sempre necessario prestare attenzione e usare il buon senso.
- Prima di utilizzare l'attrezzatura per allenarsi, riscaldarsi sempre con esercizi di stretching.
- Prima di utilizzare l'attrezzatura, controllare che dadi e bulloni siano stretti saldamente.
- Utilizzare l'attrezzatura su una superficie stabile e in piano, con una cover protettiva per il pavimento o la moquette.
- Il livello di sicurezza dell'attrezzatura può essere mantenuto solo se viene regolarmente esaminata per rilevare danni e / o usura. Se si riscontrano componenti difettosi durante l'assemblaggio o il controllo, o se si sentono rumori insoliti dall'attrezzatura durante l'uso, FERMARSI! Non utilizzare l'attrezzatura fino a quando il problema non è stato risolto.
- Indossare indumenti adatti durante l'uso. Evitare di indossare indumenti larghi che potrebbero rimanere impigliati nell'attrezzatura o che potrebbero limitare o impedire il movimento.
- Prima di iniziare qualsiasi esercizio o programma di allenamento dovrete consultare il vostro medico personale per verificare se necessitate di un esame fisico completo. Ciò è particolarmente importante se avete più di 35 anni, non vi siete mai allenati prima, siete incinta o soffrite di qualsiasi malattia.

PULIZIA E MANUTENZIONE

1. Esaminare regolarmente l'attrezzatura per rilevare eventuali danni da usura che potrebbero essersi verificati nel tempo.

Il livello di sicurezza dell'attrezzatura può essere mantenuto solo se viene controllata regolarmente per rilevare danni e usura su cavi, pulegge e raccordi.

2. Lubrificare periodicamente le parti mobili con olio leggero per prevenire l'usura prematura.

3. Ispezionare e stringere tutte le parti prima di utilizzare l'attrezzatura. Sostituire immediatamente i componenti difettosi e / o tenere l'attrezzatura fuori uso fino all'avvenuta riparazione. Prestare particolare attenzione ai componenti più soggetti a usura.

4. L'attrezzatura può essere pulita utilizzando un panno morbido e umido. Non utilizzare solventi o detergenti abrasivi.

INTRODUZIONE

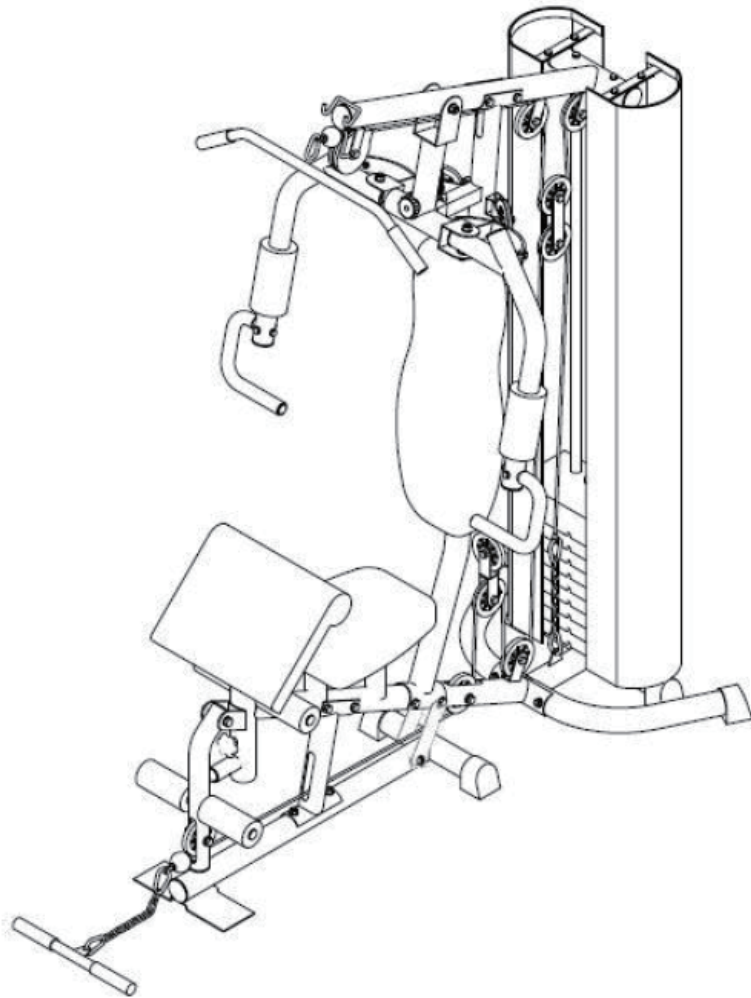

- Inserire il perno nel peso desiderato e sollevare.
- Ottimo per tirare su, tirare a sé e tirare giù, utilizzando le barre laterali.
- Per gli allenamenti per le gambe, tirare con la fascia per i piedi.
- Cuscinetti per bicipiti regolabili.

PANORAMICA

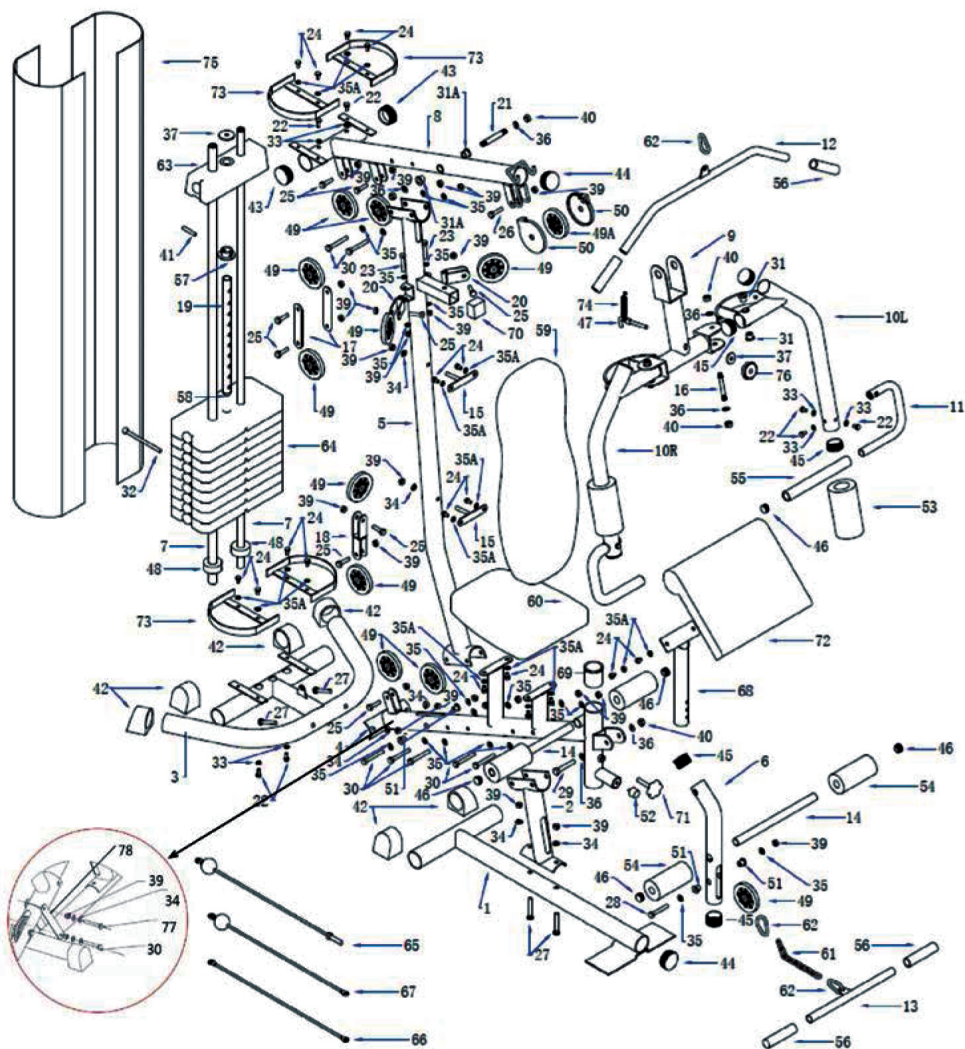

Aggiungere
componenti
di collegamento

Parti	Descrizione	Qtà	Parti	Descrizione	Qtà
1	Telaio di base	1	39	Dado in nylon M10	27
2	Reggisella	1	40	Dado in nylon M12	5
3	Stabilizzatore posteriore	1	41	Perno fisso per pesi piastre	1
4	Tubo di supporto del sedile	1	42	Tappo di chiusura	6
5	Tubo di supporto verticale	1	43	Φ60 Tappo Rotondo	2
6	Tubo per leg curl	1	44	Φ60 Tappo piatto	2
7	Tubo guida	2	45	Φ50 Tappo piatto	8
8	Tubo a ponte	1	46	Φ25 Tappo piatto	6
9	Unità per tirare	1	47	Spillo	1
10L	Braccio a farfalla- Sinistro	1	48	Anello di gomma	2
10R	Braccio a farfalla -Destra	1	49	Puleggia	11
11	Manubrio	2	49A	Puleggia A	1
12	barra laterale	1	50	Tappo per Puleggia Piccola	2
13	Barra di trazione inferiore	1	51	Boccola in plastica	4
14	Tubo in schiuma per leg curl	2	52	Tappo di gomma	1
15	Staffa per sedile/schienale	2	53	Schiuma per braccio a farfalla	2
16	Bullone a testa esagonale M12x80mm	2	54	Schiuma per Leg Curl	4
17	Staffa per Puleggia	2	55	Schiuma per manubrio	2
18	Staffa a due vie per puleggia	1	56	Impugnatura per mano	4
19	Barra Selezione	1	57	Tappo rotondo per barra di selezione	1
20	Staffa puleggia	2	58	Tappo rotondo per barra di selezione	1
21	Asse per unità di trazione	1	59	Cuscino schienale	1
22	Bullone a testa esagonale M8 x 20mm	8	60	Sedile	1
23	Bullone a testa esagonale M10 x 60mm	2	61	Catena da 8 collegamenti	2
24	Bullone a testa esagonale M8 x 15mm	22	62	Gancio	5
25	Bullone a testa esagonale M8 x 15mm	9	63	Piastra di pesi 8 libbre	1
26	Bullone a testa esagonale M10 x 45mm	1	64	Piastra di pesi 10 libbre	9
27	Bullone a testa esagonale M10 x 75mm	4	65	Cavo per barra laterale	1
28	Bullone a testa esagonale M10 x 70mm	1	66	Cavo per braccio a farfalla	1
29	Bullone a testa esagonale M12 x 80mm	1	67	Cavo per barra di trazione inferiore	1
30	Bullone a testa esagonale M10 x 80mm	6	68	Tubo di supporto per Cuscino	1
31	Anello di metallo in polvere Φ12	4	69	Boccola	1

31A	Anello di metallo in polvereΦ16	2	70	Tappo	1
32	Perno di Selezione	1	71	Manopola	1
33	Rondella curva OD20XID8.3	7	72	Cuscino per gomiti	1
34	Rondella curva OD23XID10	6	73	Staffa per la copertura in tessuto	4
35	Rondella piana OD23XID10	28	74	Molla	1
35A	Rondella piana OD23XID9	22	75	Copertura in tessuto per sinistra/destra	2
36	Rondella piana OD24XID12.3	8	76	Dado a prugna	1
37	Rondella piana OD40XID12.5	1	77	Bullone a testa esagonale M10x85mm	1
38	Dado in nylon M8	2	78	Cinghia di collegamento	2

ASSEMBLAGGIO

Passaggio A:

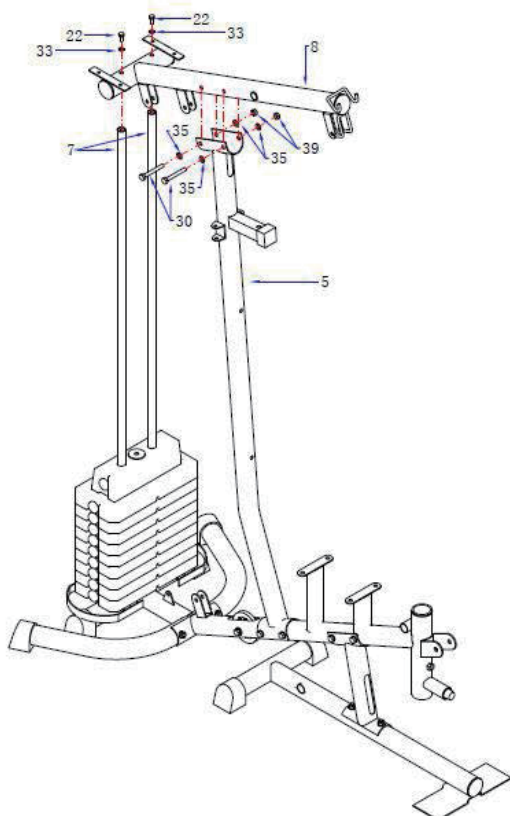

1. Fissare il reggisella (02) al telaio di base (01) utilizzando due bulloni esagonali (27), quattro rondelle curve (34) e due dadi in nylon (39).



2. Fissare il tubo di supporto del sedile (04) al reggisella (02) utilizzando due bulloni a testa esagonale (30), quattro rondelle piatte (35) e due dadi in nylon (39).



3. Fissare lo stabilizzatore posteriore (03) al tubo di supporto del sedile (04) utilizzando due bulloni a testa esagonale (27), quattro rondelle curve (34) e due dadi in nylon (39).



4. Fissare il tubo guida (07) allo stabilizzatore posteriore (03), e fissare il tubo di supporto verticale (05) al tubo di supporto del sedile (04) – serrare con due bulloni a testa esagonale (30).

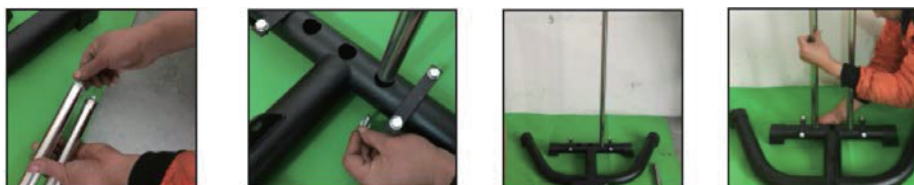

Passaggio B:

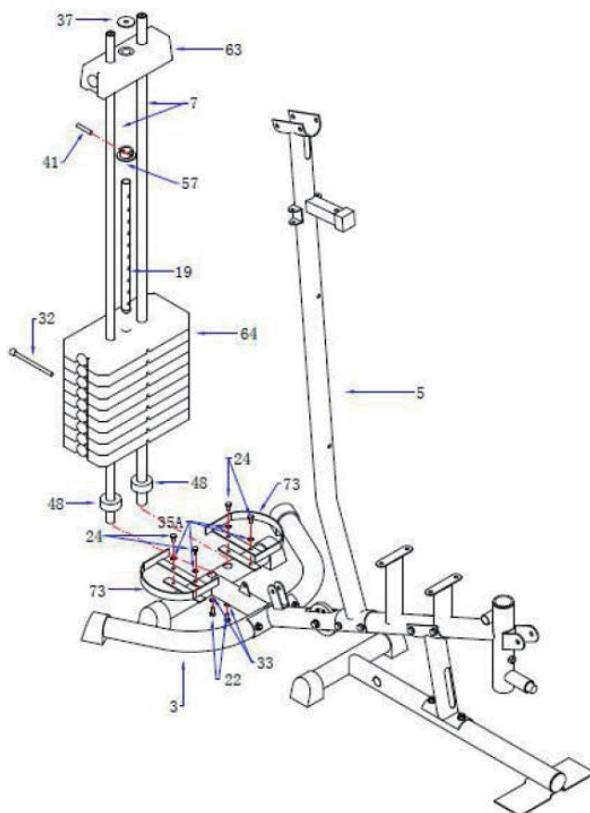

1. Fissare la staffa per la copertura in tessuto (73) al lato sinistro dello stabilizzatore posteriore (03) – serrare usando due bulloni a testa esagonale (24) e due rondelle (35A).
2. Ripetere per il lato destro dello stabilizzatore posteriore.

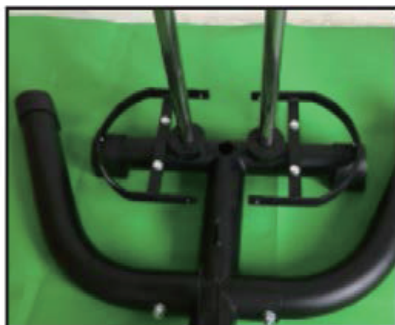

3. Far scorrere entrambi i tubi di guida (07) attraverso gli anelli di gomma (48) e nei fori dello stabilizzatore posteriore (3) – serrare dal lato inferiore utilizzando due rondelle curve (33) e due bulloni a testa esagonale (22).



4. Posizionare i pesi piastre (64) in posizione. Assicurarsi che i tubi guida (07) vengano fatti passare attraverso i fori.



5. Posizionare la boccola per i pesi piastre (57) sulla barra di selezione (19) – fissarla in posizione utilizzando il perno fisso (41). Posizionare i pesi piastre (63) sulla barra di selezione (19), e poi posizionare una rondella piatta (37) sui pesi piastre (63).



6. Inserire il perno di selezione (32) attraverso i pesi piastre (64) e nel foro della barra di selezione (19).

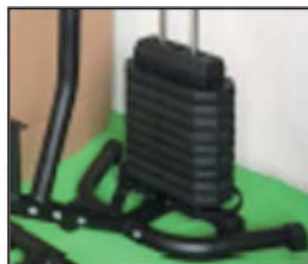

Passaggio C:

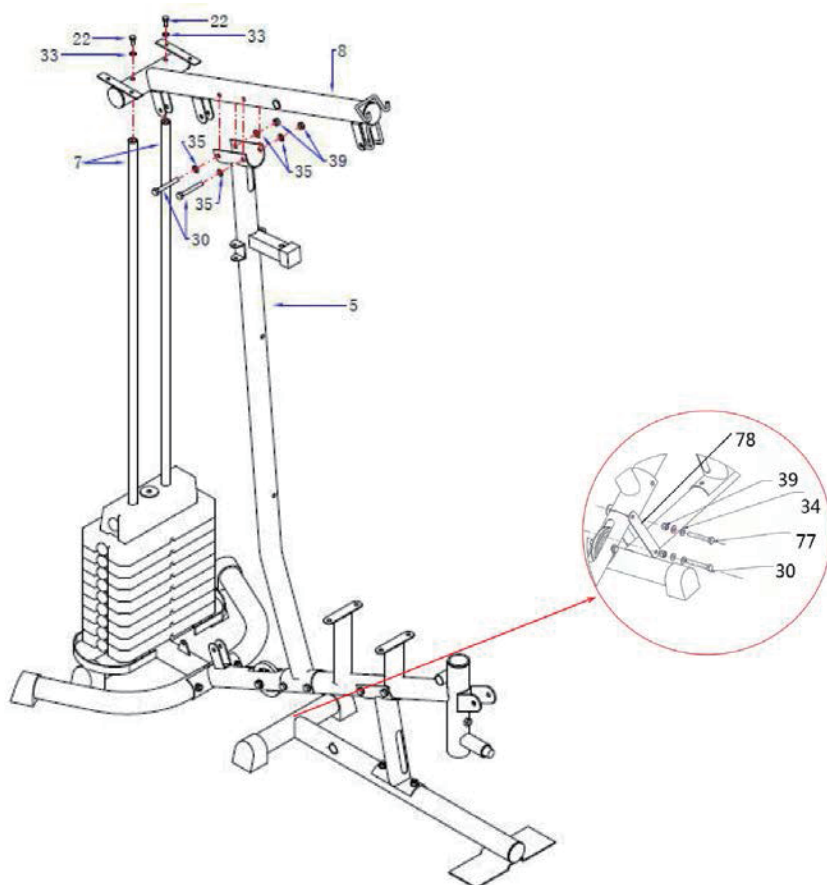

1. Fissare la staffa per la copertura in tessuto (73) nel tubo del ponte (08) utilizzando quattro bulloni a testa esagonale (24). Fissare il tubo guida (07) al tubo ponte (08) utilizzando due bulloni a testa esagonale (22).

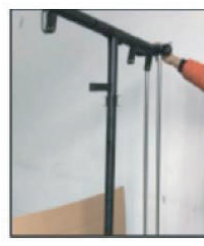

2. Fissare il tubo ponte (08) al tubo di supporto verticale (05) – fissarlo utilizzando due bulloni a testa esagonale (30), quattro rondelle piatte (35) e due dadi in nylon (39).



3. Fissare il telaio di base (01) al tubo di supporto verticale (05). Seguendo la figura sottostante, fissare le due cinghie di collegamento (78) utilizzando un bullone a testa esagonale (30), un bullone a testa esagonale (77), due rondelle piatte (34) e due dadi in nylon (39).

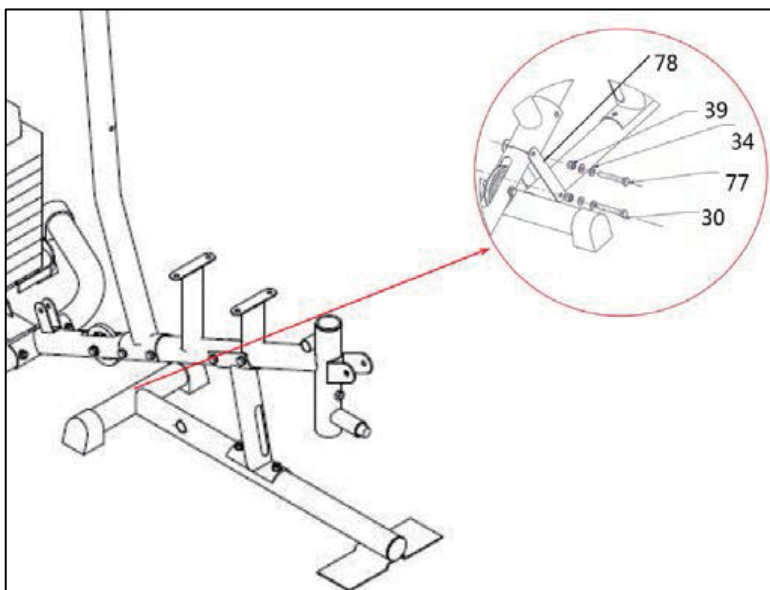

Passaggio D:

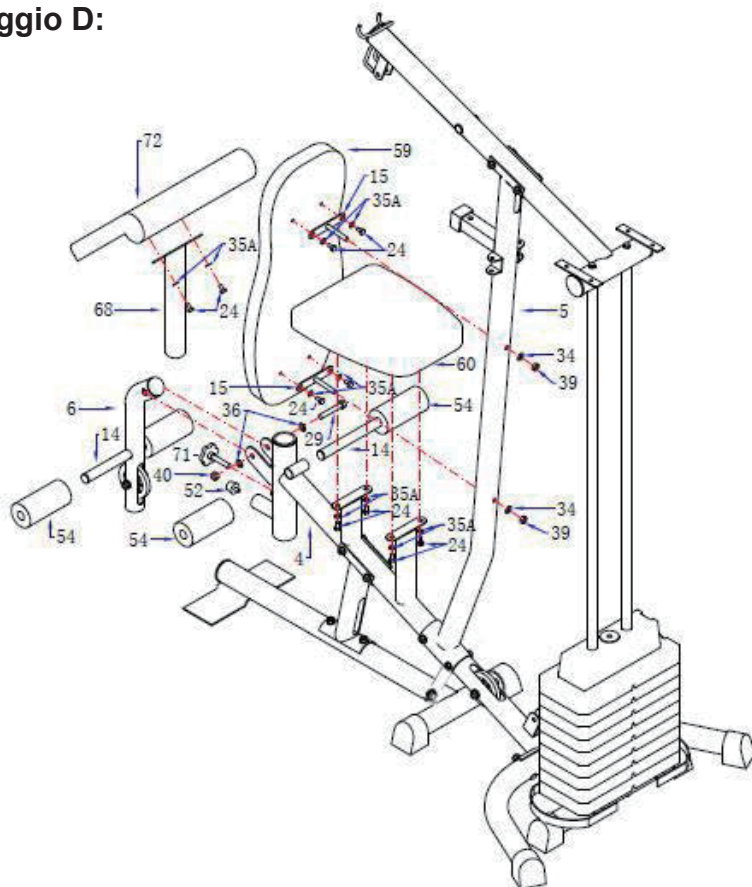

1. Fissare la staffa per lo schienale (15) al cuscino dello schienale (59) – serrare usando due rondelle piatte (35A) e due bulloni a testa esagonale (24).



2. Fissare il cuscino dello schienale (59) al tubo di supporto del montante (05), inserendo la vite della staffa per lo schienale (15) nel foro del tubo di supporto verticale (05) – fissarlo con una rondella curva (34) e un dado in nylon M10 (39).

3. Fissare il sedile (60) al tubo di supporto del sedile (04) inserendo la vite sulla staffa per il sedile nei fori – fissare utilizzando quattro rondelle piatte (35A) e quattro bulloni a testa esagonale (24).



4. Attaccare il cuscino per gomiti (72) sul tubo di supporto del cuscino per gomiti (68) – serrare usando due rondelle (35A) e due bulloni a testa esagonale (24). Fissare il cuscino per gomiti (68) nel tubo di supporto del sedile (04) – fissarlo con la manopola (71).

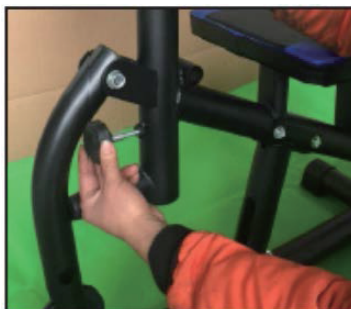

5. Avvitare il piccolo tappo di gomma (52) nella parte anteriore del tubo di supporto del sedile (04). Fissare il tubo della curva gamba (06) alla parte anteriore del tubo di supporto del sedile (04) – serrare con un bullone a testa esagonale (29), due rondelle piatte (36) e un dado in nylon (40).

6. Attaccare due tubi in schiuma per leg curl (14) nei fori del tubo per leg curl (06) e la staffa anteriore/superiore del tubo di supporto del sedile (04).



7. Attaccare le due schiume per il tubo per leg curl (54) su entrambi i lati di ciascun tubo per leg curl (14).



Passaggio E:

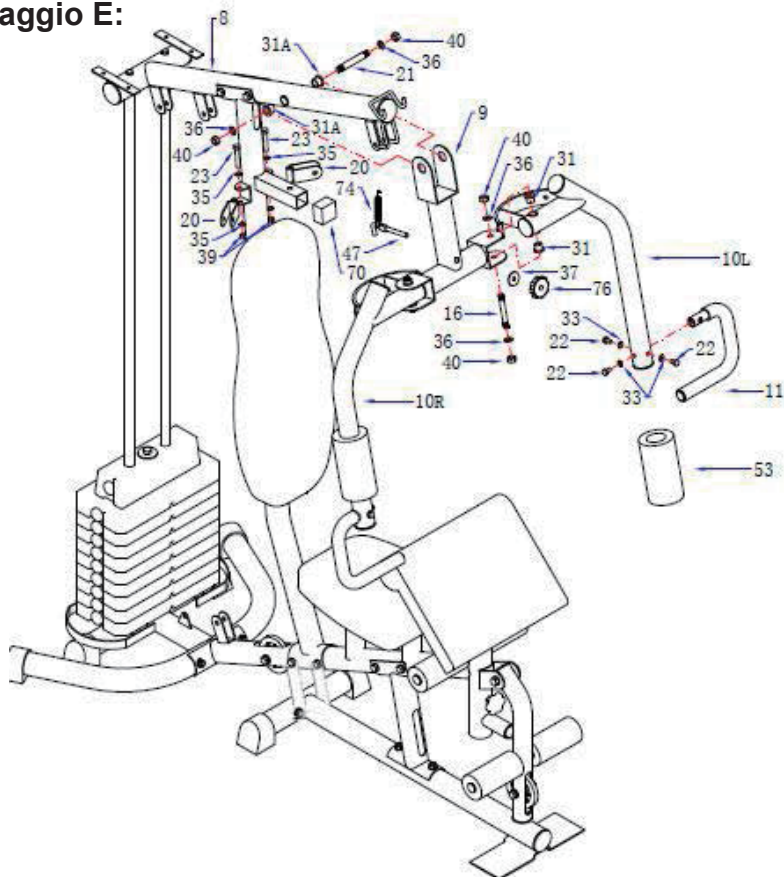

1. Fissare l'unità di trazione (09) al tubo ponte (08), e inserire l'asse per l'unità di trazione (21) – fissarla con due anelli in polvere (31A), due rondelle piatte (36) e due dadi in nylon (40). Fare riferimento alla figura in Passaggio E.



2. Fissare il braccio a farfalla destro (10R) al lato destro dell'unità di trazione (09) utilizzando due anelli di metallo in polvere (31), un bullone a testa esagonale (16) e due rondelle piatte (36) – serrare con due dadi in nylon (40).

Ripetere per il braccio a farfalla L (10L).

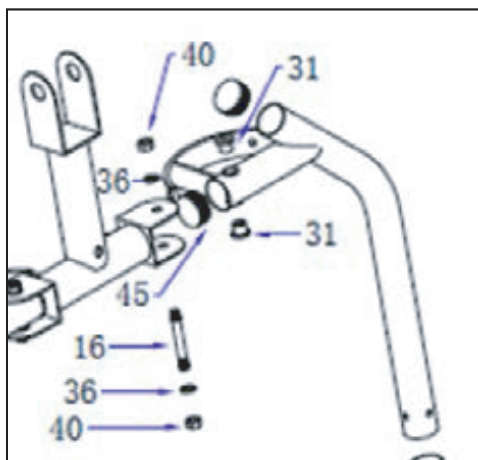

3. Posizionare il tappo in gomma (70) sulla staffa sul tubo di supporto verticale (05). Regolare l'unità di trazione (09) in modo che corrisponda al foro nella staffa.

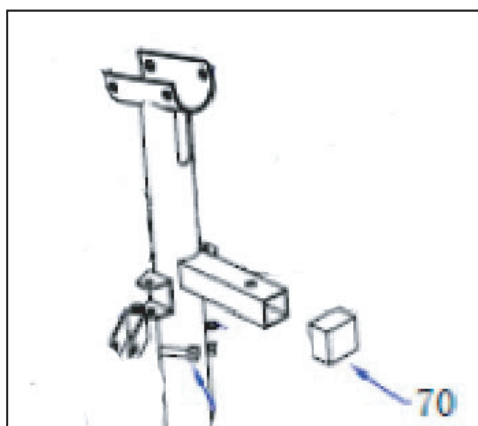

4. Mettere la schiuma per il braccio a farfalla (53) nel braccio a farfalla destro e sinistro (10R e 10L) e regolare alla posizione desiderata.



5. Fissare il manubrio (11) al braccio a farfalla destro (10R) – serrare usando tre rondelle curve (33) e tre bulloni a testa esagonale (22).

Ripetere per il braccio a farfalla sinistro (10L) utilizzando l'altro manubrio (11L).

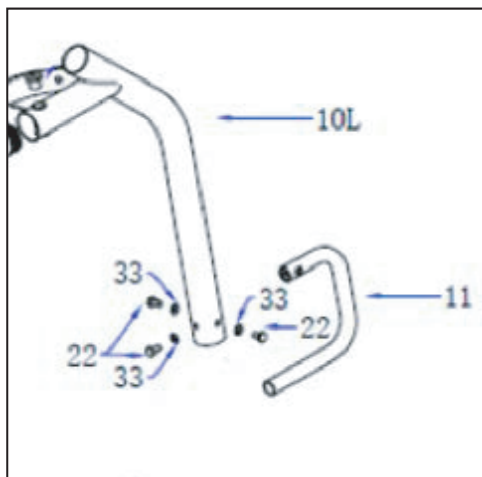

6. Attaccare due staffe della puleggia (20) su entrambi i lati del tubo di supporto verticale (05) – serrare utilizzando due bulloni a testa esagonale (23), quattro rondelle piatte (35) e due dadi in nylon (39).

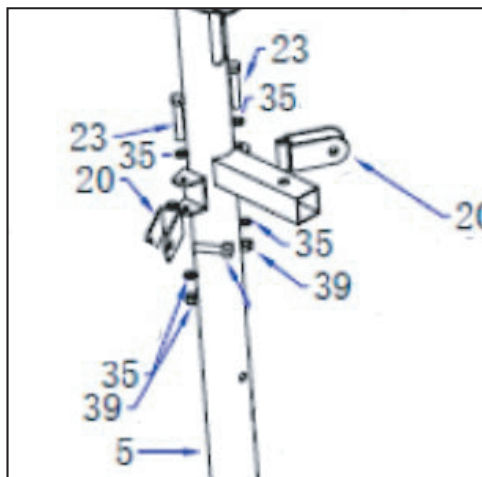

Passaggio F:

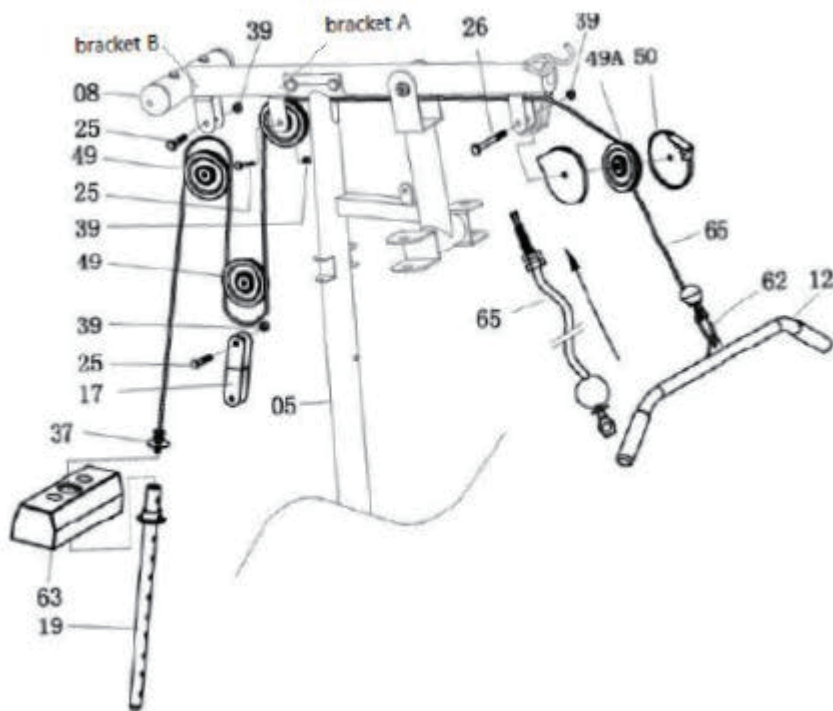

1. Fissare il cavo per la barra laterale (65) alla staffa di apertura nella parte anteriore del tubo ponte (8).

Nota: il tappo a sfera del cavo (65) deve trovarsi sotto il tubo ponte (8).

Nota: Il cavo (65) deve uscire dal tappo (50) dai lati dell'apertura.

Fissare alla staffa utilizzando un bullone a testa cilindrica (26) e un dado in nylon (39).

2. Tirare il cavo (65) verso la parte posteriore dell'attrezzatura attraverso l'apertura superiore del tubo di supporto verticale (05) e attorno alla puleggia (49), e poi fissare la puleggia (49) sulla staffa A (fare riferimento al figura in Passaggio F). Serrare con un bullone a testa esagonale (25) e un dado in nylon (39).

3. Tirare il cavo (65) verso il basso attorno alla puleggia (49). Fissare la puleggia (49) con la staffa (17) su entrambi i lati – serrare con un bullone a testa esagonale (25) e un dado in nylon (39).

4. Tirare il cavo (65) verso l'alto attorno alla puleggia (49). Fissare la puleggia (49) alla staffa B – serrare con un bullone a testa esagonale (25) e un dado in nylon (39). Fare riferimento alla figura in Passaggio F.

5. Tirare il cavo (65) verso il basso tra i due tubi guida (07), e poi avvitare completamente il bullone all'estremità del cavo (65) nell'apertura superiore della barra di selezione (19).

6. Fissare la barra laterale (12) all'estremità anteriore del cavo (65), e collegare utilizzando il gancio (62).

Passaggio G:

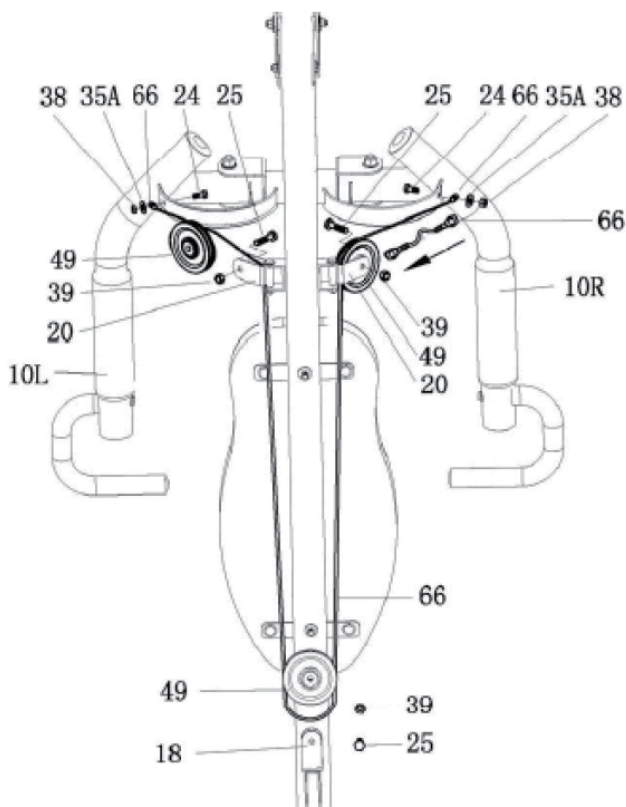

1. Fissare un'estremità del cavo per il braccio a farfalla (66) al gancio sul braccio a farfalla destro (10R) – serrare utilizzando un bullone a testa esagonale (24), una rondella piatta (35A) e un dado in nylon (38) .
2. Far passare il cavo (66) attorno alla puleggia (49), e poi fissare la puleggia (49) alla staffa (20) sul lato destro del tubo di supporto verticale (05) – serrare con un bullone a testa esagonale (25) e un bullone in nylon (39).
3. Far passare l'altra estremità del cavo (66) verso il basso attorno alla puleggia (49). Fissare la puleggia (49) alla parte superiore della staffa a due vie (18) – serrare con una vite a testa esagonale (25) e un dado in nylon (39).

4. Far passare il cavo (66) verso l'alto attorno alla puleggia (49). Fissare la puleggia (49) alla staffa (20) sul lato sinistro del tubo di supporto verticale (05) – serrare con un bullone a testa esagonale (25) e un dado in nylon (39).

5. Fissare l'estremità del cavo (66) al gancio sul braccio a farfalla sinistro (10L) – serrare utilizzando un bullone a testa esagonale (24), una rondella piatta (35A) e un dado in nylon (38).

Passaggio H:

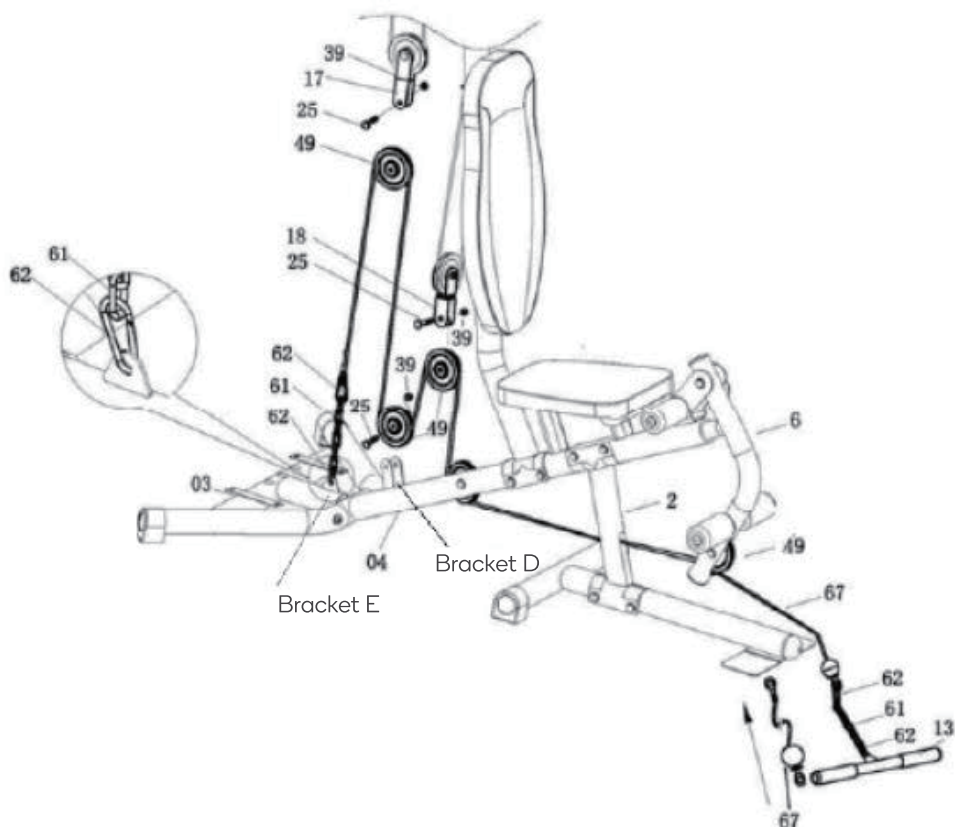

1. Fissare l'estremità con il tappo sferico del cavo per la barra di trazione inferiore (67) al leg curl con staffa aperta (6), attorno alla parte inferiore della puleggia (49). Far passare il cavo (67) attraverso l'apertura nella parte inferiore del reggisella (02), attorno alla puleggia (49) dal lato inferiore. Tirare il cavo (67) verso l'alto attorno al lato superiore della puleggia (49). Fissare la puleggia (49) alla parte inferiore della staffa a due vie (18) – serrare con un bullone a testa esagonale (25) e un dado in nylon (39).

2. Far passare il cavo (67) verso il basso e attorno alla parte inferiore della puleggia (49). Fissare la puleggia (49) alla staffa D sul tubo reggisella (4) – serrare con un bullone a testa esagonale (25) e un dado in nylon (39).

3. Tirare il cavo (67) verso l'alto attorno al lato superiore della puleggia (49). Fissare la puleggia (49) alla parte inferiore della staffa (17) – serrare con un bullone a testa esagonale (25) e un dado in nylon (39).

4. Far scorrere il cavo (67) verso il basso e collegarlo con la staffa E sullo stabilizzatore posteriore utilizzando la catena di collegamento (61) e un gancio (62).

Nota: Regolare il cavo (67) in modo che sia ben teso, e poi bloccare nella posizione desiderata della catena di collegamento (61) utilizzando il gancio (62).

5. Fissare la barra di trazione inferiore (13) all'estremità anteriore del cavo (67). Collegare utilizzando la catena di collegamento (61) e due ganci (62). Fare riferimento alla figura in Passaggio G.

Passaggio I:

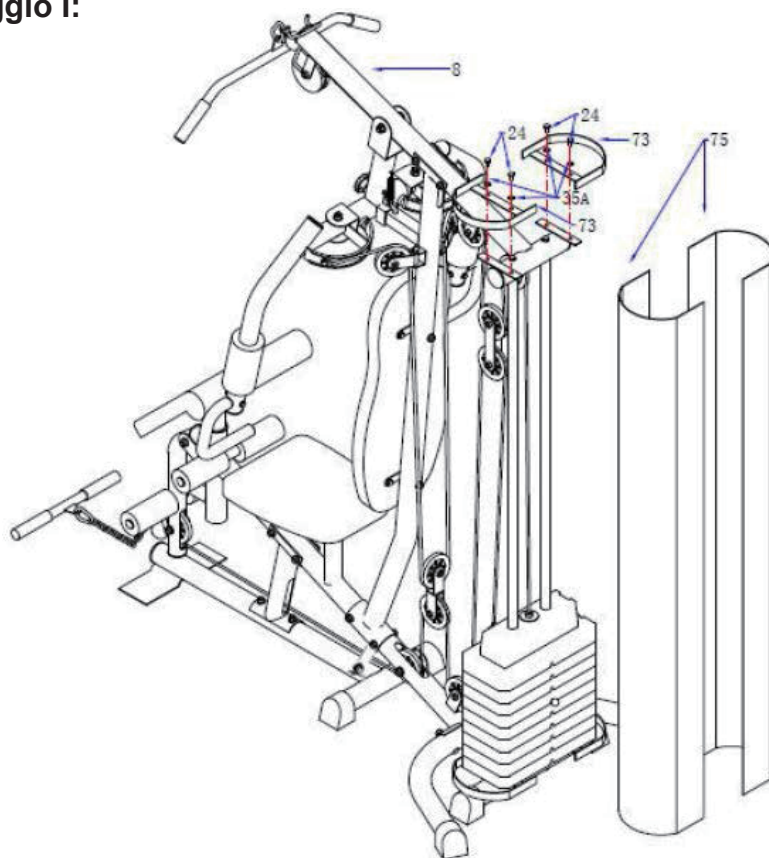

1. Fissare la staffa per la copertura in tessuto L (73) al tubo ponte (08) - serrare con due viti a testa esagonale (24) e due rondelle piatte (35A).

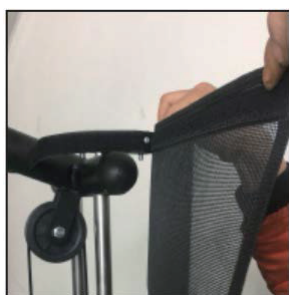



IN230600152V01_IT

A91-234V00

GYM STATION

EN

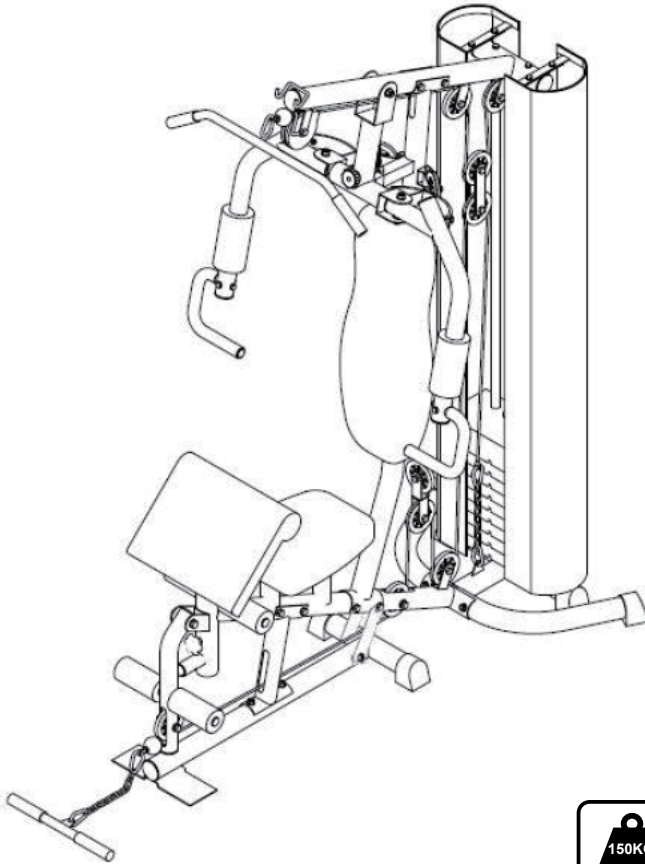









IMPORTANT, RETAIN FOR FUTURE REFERENCE: READ CAREFULLY











ASSEMBLY INSTRUCTION

PACKING DETAILS: TOTAL 4 BOXES







BOX-1/4

Accessory Box

NO.	Description	Qty
1	Base frame 	1
3	Rear stabiliser 	1
4	Seat support tube 	1
5	Upright support tube 	1
7	Guiding tube 	2
9	pull unit 	1
59	back cushion 	1
60	seat 	1
75	Cloth cover for right/left 	2













NO.	Description	Qty
49	pulley 	11
49A	pulley A 	1
50	Cap for small pulley 	2
65	Cable for lat bar 	1
66	Cable for butterfly arm 	1
67	Cable for lower pull bar 	1
13	Lower pull bar 	1
11	Handlebar 	2
55	Foam for handlebar 	2
15	Bracket for seat/backrest 	2

Accessory Box

NO.	Description	Qty
17	Bracket for bulley 	2
18	Two way bracket for bulley 	1
20	bulley bracket 	2
78	connection strap 	2
48	Rubber ring 	2
57	Round cap for select bar 	1
71	Knob 	1

PACKING DETAILS: TOTAL 4 BOXES



BOX-2/4

NO	Description		Qty
10L /R	butterfly arm L/R		2
2	Seat post		1
8	bridge tube		1
12	lat bar		1
53	foam for butterfly arm		2
54	foam for leg curl		4
72	elbow cushion		1
73	bracket for cloth cover		4
6	leg curl tube		1
68	cushion support tube		1
19	select bar		1
	hardware		2

BOX-3/4

NO.	Description		Qty
64	weight plate		5

BOX-4/4

NO.	Description		Qty
64	weight plate		4
63	weight plate		1

Introduction 3

Safety & Warnings..... 7

Overview 8

Assembly 11



IMPORTANT MESSAGE
WARNING - PLEASE READ

ADULT ASSEMBLY REQUIRED
CHOKING HAZARD Small Parts.
NOT for children under 3 years of age.

WARNING:

While every attempt is made to ensure the highest degree of protection in all equipment, we cannot guarantee freedom from injury. The user assumes all risks of injury due to use. All merchandise is sold on this condition, which no representative of the company can waive or change.

SAFETY INFORMATION

IMPORTANT – Please read fully before assembly or use.

This exercise equipment is built for optimum safety. However, certain precautions apply whenever you operate a piece of exercise equipment. Be sure to read the entire manual before you assemble, operate, or use this equipment, note the following safety precautions.

Warning for assembly

- Ensure you have all the parts and tools listed.
- Remove all fittings from the plastic bags and separate them into their groups.
- Keep children and animals away from the work areas, small parts can cause a choking hazard if swallowed.
- Ensure you have enough space to layout the parts before starting.

The assembly of this equipment is best carried out by 2 persons.

- Assemble the item as close to its final position (in the same room) as possible.
- The free-standing equipment shall be installed on a stable and level base.
- Dispose of all packaging carefully and responsibly.

Warning for using

- This exercise equipment is made for training in private environment. Only use the equipment for its intended use.
- **DO NOT** make any changes to the equipment which can affect the security of the product.
- **Warning! Pregnant or physically injured persons should never use the weight station without prior consultation with a doctor you trust.**
- Be aware of your body's signals. Incorrect or excessive exercise can damage your health.
- STOP exercising if you experience any pain, tightness in your chest, irregular heartbeat, extreme shortness of breath, lightheadedness, dizziness, or nausea. If you do experience any of these conditions you should **CONSULT YOUR DOCTOR IMMEDIATELY** before continuing with your exercise program.
- Always adapt your training style to your personal fitness level and health.
- Before every training session, ensure you check the equipment for operation and safety.
- Before using, ensure the item is installed correctly and that all safety devices are functional! Damages or alterations to the product resulting from modification, will invalidate your warranty. For problems resulting from the modification or other restrictions, the seller is not responsible.

- Any damage must be reported to the seller immediately after delivery, and before use or installation. Later complaints will not be considered.
- Use only suitable tools for assembly.
- The installation must ONLY be carried out by adults. Children should not be present in the immediate environment where the assembly is taking place.
- Make sure all connections are securely mounted before releasing the product for use.
- Check all connections at regular intervals for damage, loose elements and other factors that can lead to a loss of sufficient security.
- Do not leave children unattended on the weight bench! It is not a toy! Instruct them not to play with or climb on the appliance.
- In case of a fault during day-to-day use, or during maintenance, lock the equipment to prevent any risk of injury.
- Children or persons with limited physical or mental abilities, or those not familiar with this device, should not be allowed to use this weight bench!
- Please keep in mind that this manual and the safety can only draw your attention to eventual hazard. Logical conclusions and care should always be practiced when handling this device.
- Before using the equipment to exercise, always warm up with stretching exercises.
- Before using the equipment, check the nuts and bolts are securely tightened.
- Use the equipment on a solid, flat surface with a protective cover for your floor or carpet.
- The safety level of the equipment can only be maintained if it is regularly examined for damage and/or wear and tear. If you find any defective components whilst assembling or checking the equipment, or if you hear any unusual sounds, from the equipment during use, STOP! Do not use the equipment until the problem has been rectified.
- Wear suitable clothing whilst using the equipment. Avoid wearing loose clothing which may get caught in the equipment or that may restrict or prevent movement.
- Before starting any exercise or conditioning program you should consult with your personal physician to see if you require a complete physical exam. This is especially important if you are over the age of 35, have never exercised before, are pregnant, or suffer from any illness.

CLEANING AND MAINTENANCE

1. Regularly examine the equipment to detect any damage to wear which may have occurred.

The safety level of the equipment can be maintained only if it is examined regularly for damage and wear and tear on ropes, pulleys, and connection points.

2. Lubricate moving parts with light oil periodically to prevent premature wear.

3. Inspect and tighten all parts before using the equipment. Replace defective components immediately and/or keep the equipment out of use until repair. Pay particular attention to components most susceptible to wear.

4. The equipment can be cleaned using a soft, damp cloth. Do not use solvents or abrasive cleaners.

INTRODUCTION

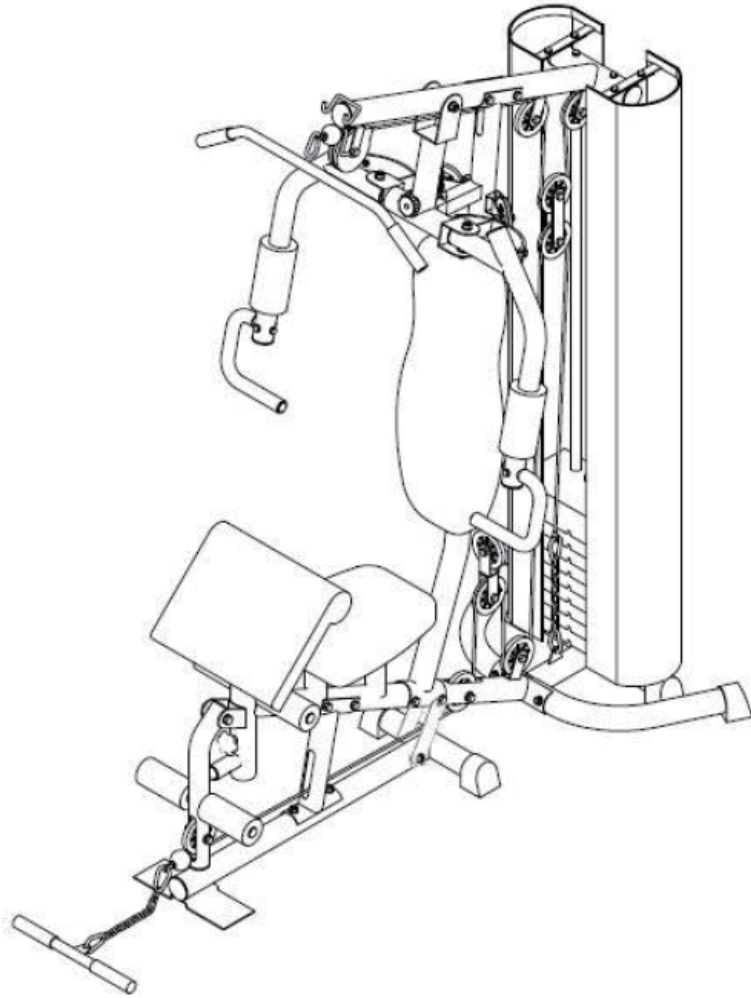

- Insert the pin into your desired weight and lift.
- Great for pull-ups, pullovers and pull-downs, using the lateral bars.
- For leg workouts, pull with the footwrap.
- Adjustable bicep pads.

Part	Description	Qty	Part	Description	Qty
1	Base Frame	1	39	M10 Nylon Nut	27
2	Seat post	1	40	M12 Nylon Nut	5
3	Rear Stabiliser	1	41	Fixed Pin for Weight Stack	1
4	Seat Support Tube	1	42	End Cap	6
5	Upright Support Tube	1	43	Φ60 Round Cap	2
6	Leg Curl Tube	1	44	Φ60 Flat Cap	2
7	Guiding Tube	2	45	Φ50 Flat Cap	8
8	Bridge Tube	1	46	Φ25 Flat Cap	6
9	Pull unit	1	47	Pin	1
10L	Butterfly Arm – Left	1	48	Rubber Ring	2
10R	Butterfly Arm – Right	1	49	Pulley	11
11	Handlebar	2	49A	Pulley A	1
12	Lat Bar	1	50	Cap for Small Pulley	2
13	Lower Pull Bar	1	51	Plastic Bushing	4
14	Foam Tube for Leg curl	2	52	Rubber Stopper	1
15	Bracket for Seat/Backrest	2	53	Foam for Butterfly Arm	2
16	Hex Head Bolt M12x80mml	2	54	Foam for Leg Curl	4
17	Bracket for Pulley	2	55	Foam for Handlebar	2
18	Two Way Bracket for Pulley	1	56	Hand Grip	4
19	Select Bar	1	57	Round Cap for Select Bar	1
20	Pulley Bracket	2	58	Round Cap for Select Bar	1
21	Axle for Pull Unit	1	59	Back cushion	1
22	Hex Head Bolt M8 x 20mmL	8	60	Seat	1

23	Hex Head Bolt M10 x 60mm	2	61	Chain 8 Links	2
24	Hex Head Bolt M8 x 15mm	22	62	Hook	5
25	Hex Head Bolt M10 x 40mm	9	63	Weight Stack 8 Lbs	1
26	Hex Head Bolt M10 x 45mm	1	64	Weight Stack 10 Lbs	9
27	Hex Head Bolt M10 x 75mm	4	65	Cable for Lat Bar	1
28	Hex Head Bolt M10 x 70mm	1	66	Cable for Butterfly Arm	1
29	Hex Head Bolt M12 x 80mm	1	67	Cable for Lower Pull Bar	1
30	Hex Head Bolt M10 x 80mm	6	68	Cushion Support tube	1
31	Powder Metal Ring Φ 12	4	69	Bushing	1
31A	Powder Metal Ring Φ 16	2	70	Stopper	1
32	Select Pin	1	71	Knob	1
33	Curve Washer OD20XID8.3	7	72	Elbow Cushion	1
34	Curve Washer OD23XID10	6	73	Bracket for Cloth Cover	4
35	Flat Washer OD23XID10	28	74	Spring	1
35A	Flat Washer OD23XID9	22	75	Cloth Cover for Left/Right	2
36	Flat Washer OD24XID12.3	8	76	Plum-nut	1
37	Flat Washer OD40XID12.5	1	77	Hex Head Bolt M10x85mm	1
38	M8 Nylon Nut	2	78	Connection strap	2

ASSEMBLY

Step A:

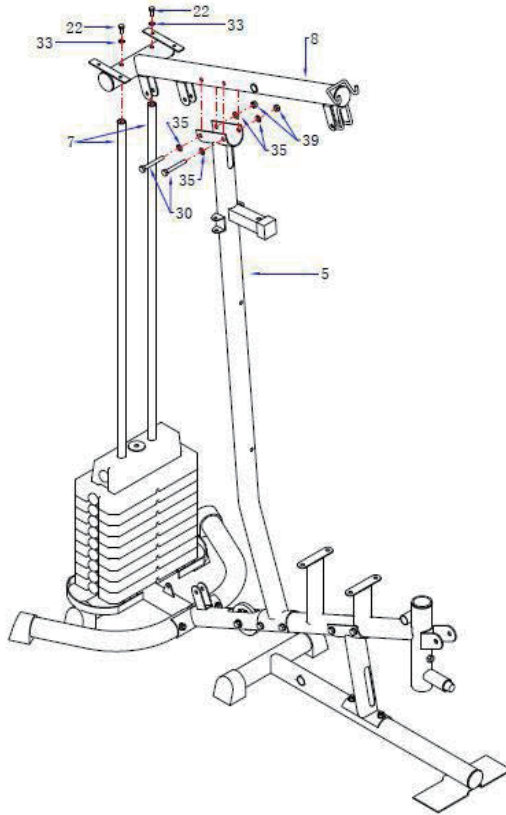

1. Attach the seat post (02) to the base frame (01) using two hex bolts (27), four curve washers (34) and two nylon nuts (39).



2. Attach the seat support tube (04) to the seat post (02) using two hex head bolts (30), four flat washers (35) and two nylon nuts (39).



3. Attach the rear stabiliser (03) to the seat support tube (04) using two hex head bolts (27), four curve washers (34) and two nylon nuts (39).



4. Attach the guiding tube (07) to the rear stabiliser (03), then attach the upright support tube (05) to the seat support tube (04) – tighten using two hex head bolts (30).

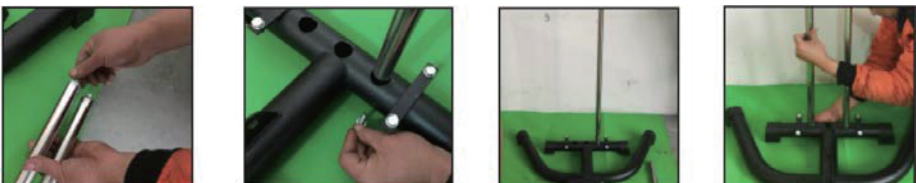

Step B:

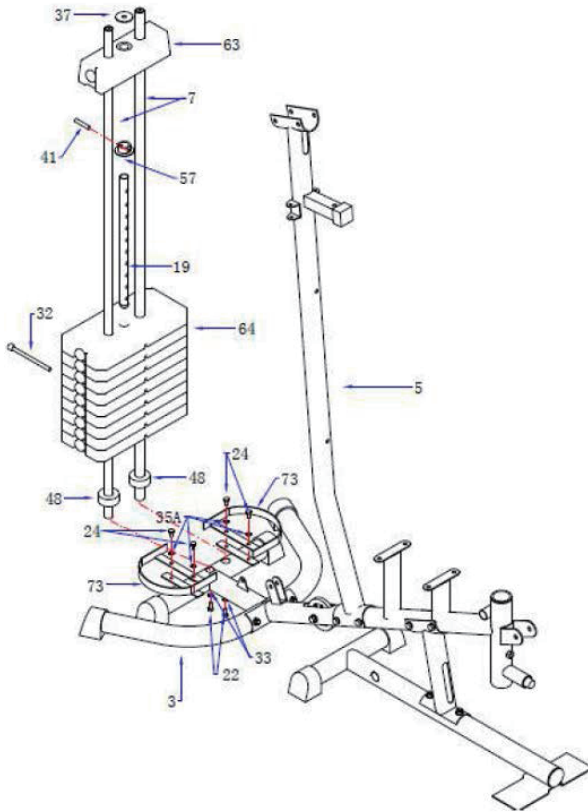

1. Attach the bracket for the cloth cover (73) to the left side of the rear stabiliser (03) – tighten using two hex head bolts (24) and two washers (35A).
2. Repeat for the right side of the rear stabiliser.

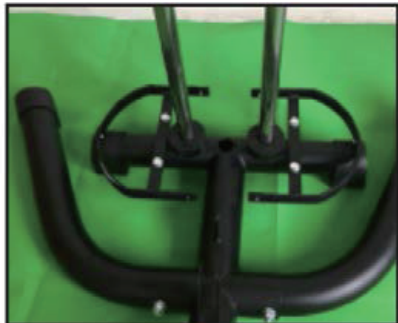

3. Slide both guiding tubes (07) through the rubber rings (48) and into the holes of the rear stabiliser (3) – tighten from the bottom side using two curve washers (33) and two head hex bolts (22).



4. Place the weight stack (64) into position. Ensure the guiding tubes (07) are fed through the holes.



5. Place the bushing for the weight stack (57) onto the select bar (19) – secure in place using the fixed pin (41). Place the weight stack (63) on the select bar (19), then place a flat washer (37) onto the weight stack (63).



6. Insert the select pin (32) through the weight stack (64) and into the hole of the select bar (19).

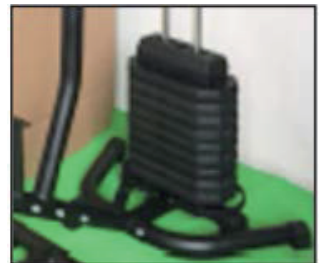

Step C:

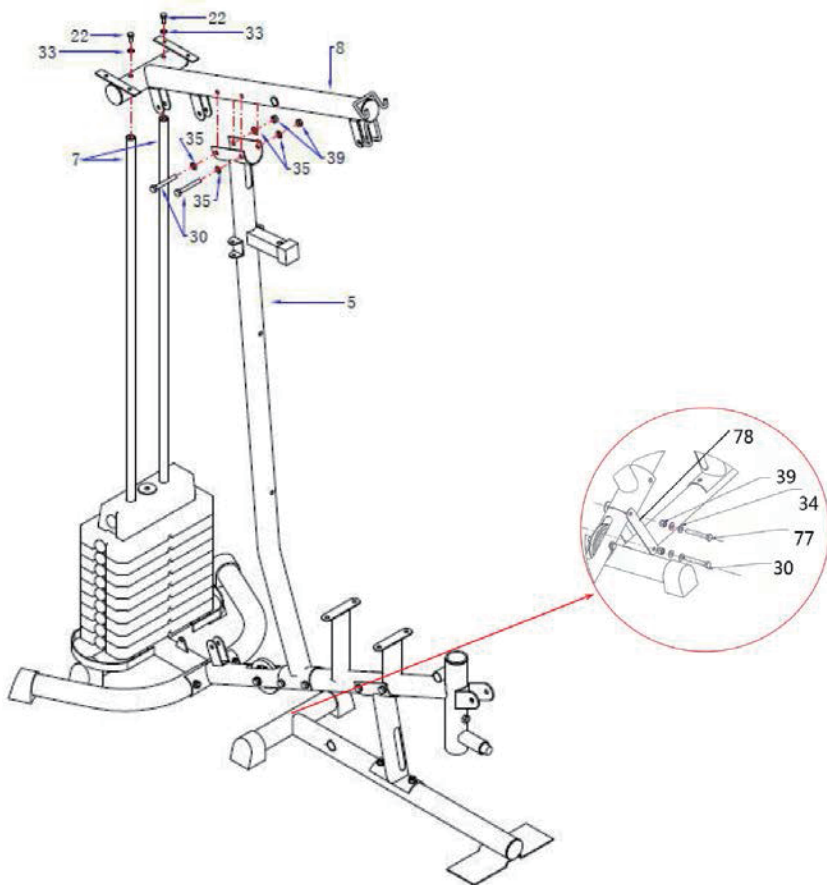

1. Attach the bracket for the cloth cover (73) into the bridge tube (08) using four hex head bolts (24). Attach the guiding tube (07) to the bridge tube (08) using two hex head bolts (22).

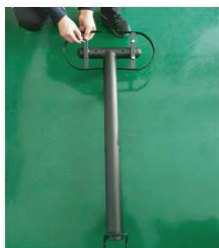

2. Attach the bridge tube (08) to the upright support tube (05) – secure using two hex head bolts (30), four flat washers (35) and two nylon nuts (39).



3. Attach the base frame (01) to the upright support tube (05). Following the diagram, attach the two connection straps (78) using a hex head bolt (30), hex head bolt (77), two flat washers (34) and two nylon nuts (39).

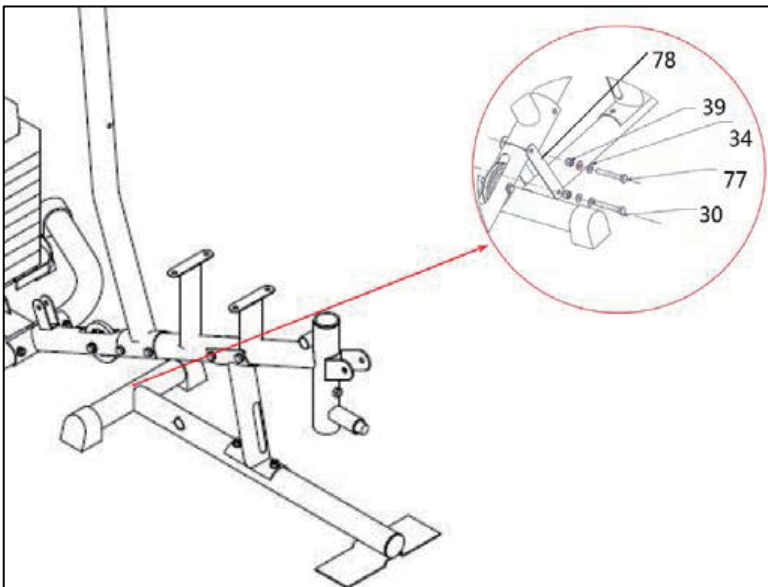

Step D:

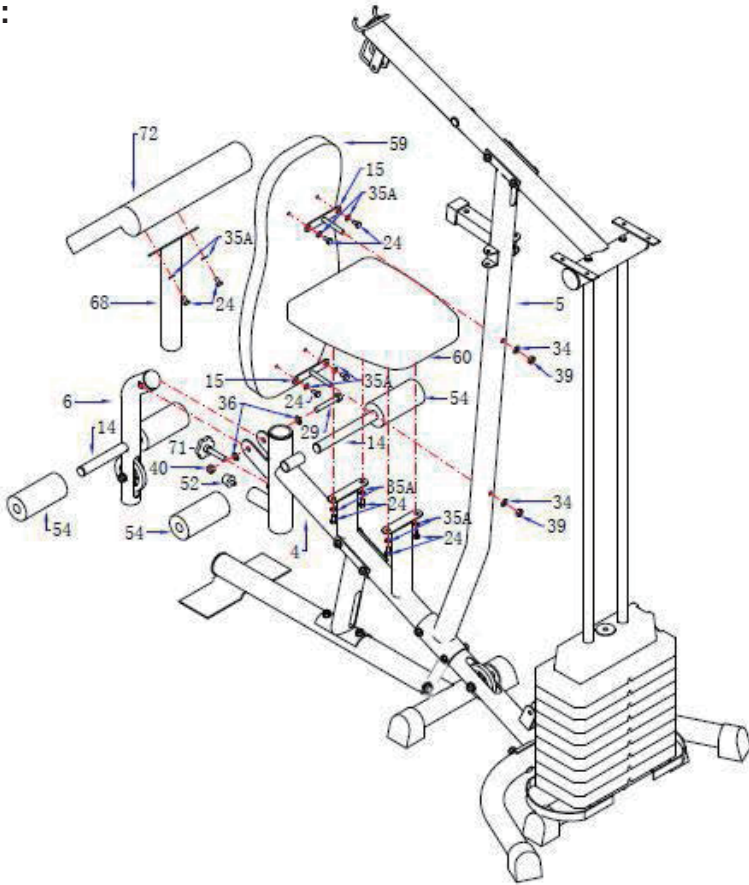

1. Attach the bracket for the backrest (15) to the back cushion (59) – tighten using two flat washers (35A) and two hex head bolts (24).



2. Attach the backrest cushion (59) to the upright support tube (05), by putting the screw on the bracket for the backrest (15) into the hole in the upright support tube (05) – secure using a curve washer (34) and an M10 nylon nut (39).

3. Attach the seat (60) onto the seat support tube (04) by putting the screw on the bracket for the seat into the holes – secure using four flat washers (35A) and four hex head bolts (24).

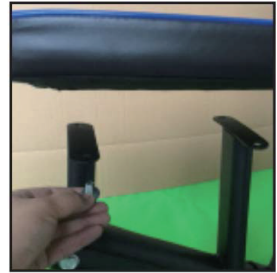

4. Attach the elbow cushion (72) onto the elbow cushion support tube (68) – tighten using two washers (35A) and two hex held bolts (24). Attach the elbow cushion (68) into the seat support tube (04) – secure with the knob (71).



5. Screw in the small rubber stopper (52) into the front side of the seat support tube (04). Attach the leg curve tube (06) to the front side of the seat support tube (04) – tighten using a hex head bolt (29), two flat washers (36) and a nylon nut (40).

6. Attach two foam tubes for the leg curl (14) into the holes on the leg curl tube (06) and the front/upper bracket of the seat support tube (04).



7. Attach the two foams for leg curl tube (54) onto both sides of each tube for leg curl (14).



Step E:

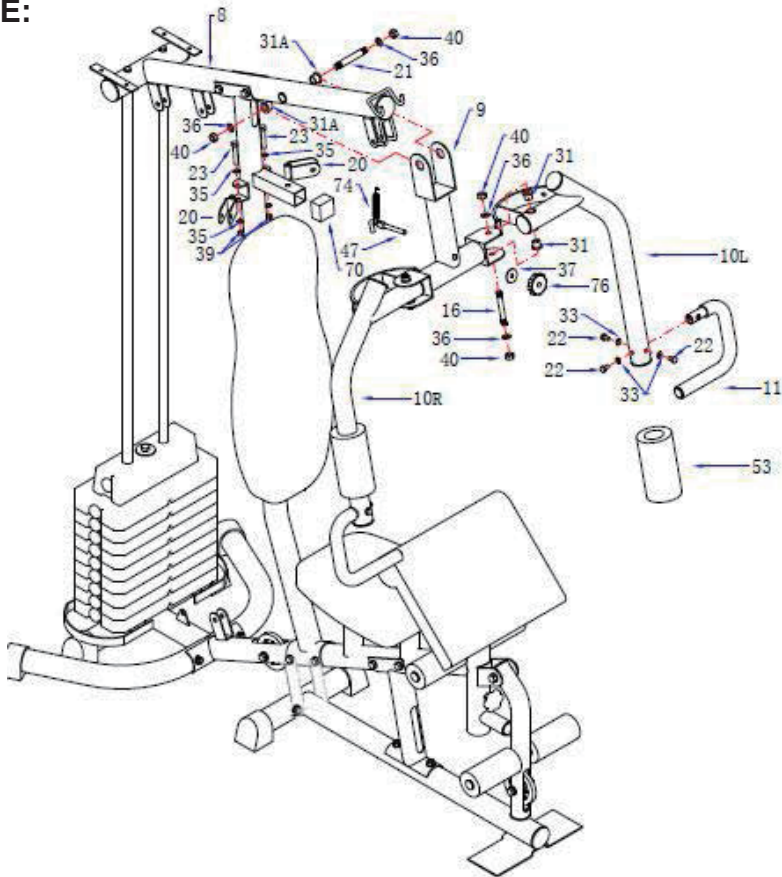

1. Attach the pull unit (09) to the bridge tube (08), then insert the axle for the pull unit (21) – secure using two powder rings (31A), two flat washers (36) and two nylon nuts (40). Refer to the ‘Step E’ diagram.



-6-

2. Attach the right butterfly arm (10R) to the right side of the pull unit (09) using two powder metal rings (31), a hex head bolt (16) and two flat washers (36) – tighten using two nylon nuts (40). Repeat for butterfly arm L (10L).

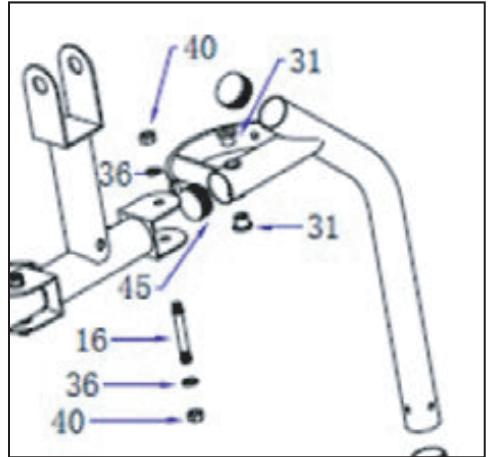

3. Place the rubber stopper (70) onto the bracket on the upright support tube (05). Adjust the pull unit (09) to match the hole in the bracket.

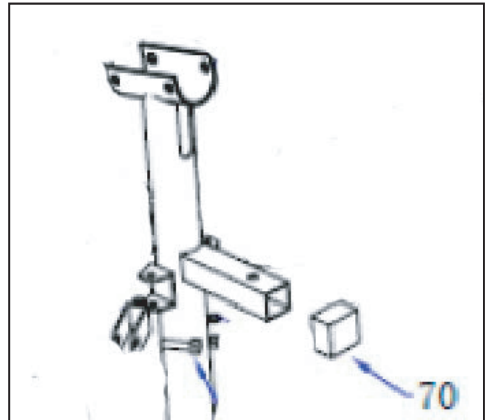

4. Put the foam for the butterfly arm (53) into the right and left butterfly arm (10R & 10L) – adjust to your desired position.



5. Attach the handlebar (11) onto the right butterfly arm (10R) – tighten using three curve washers (33) and three hex head bolts (22).

Repeat for the left butterfly arm (10L) using the other handlebar (11L).

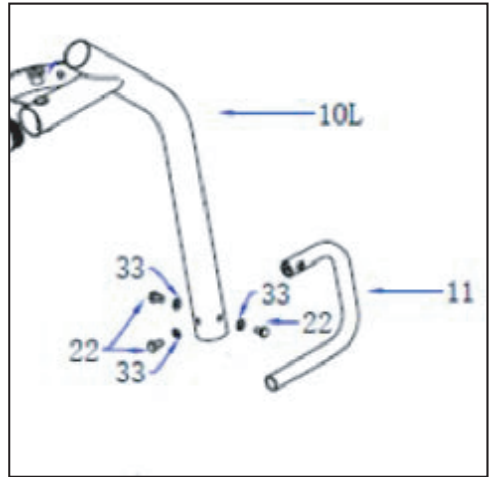

6. Attach two pulley brackets (20) onto both sides of the upright support tube (05) – tighten using two hex head bolts (23), four flat washers (35) and two nylon nuts (39).

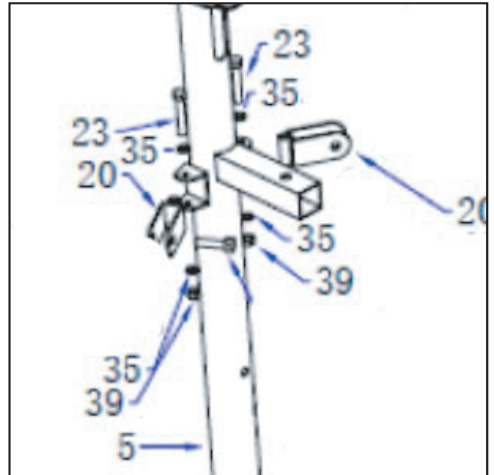

Step F:

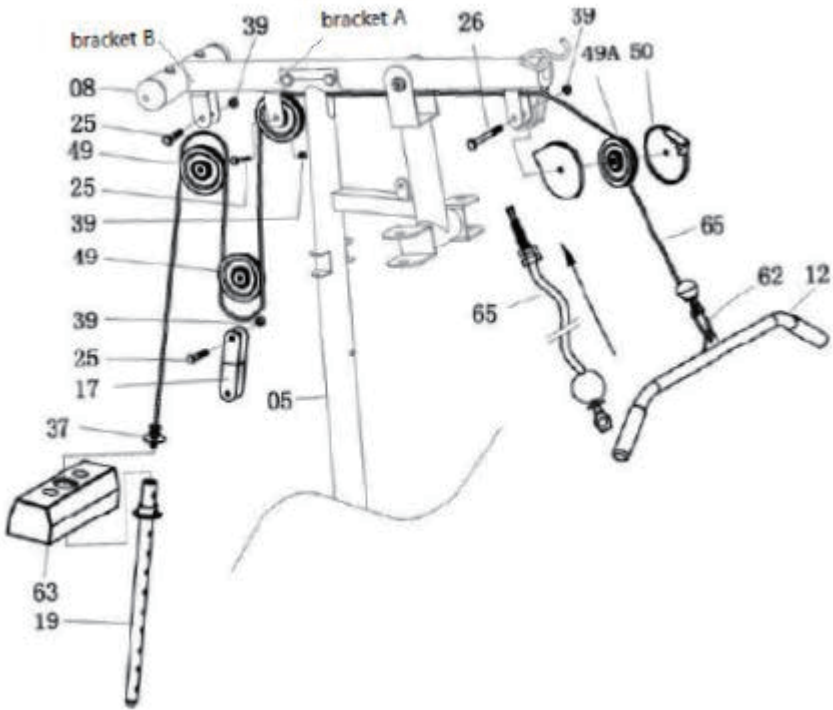

1. Attach cable for the lat bar (65) to the opening bracket at the front of the bridge tube (8).

Note: The ball stopper of the cable (65) should be underneath the bridge tube (8).

Note: The cable (65) must come out of the cap (50) from the opening sides. Tighten to the bracket using a head bolt (26) and nylon nut (39).

2. Draw the cable (65) towards the back side of the machine through the upper opening of upright support tube (05) and around the pulley (49), then attach the pulley (49) onto bracket A (refer to the 'Step F' diagram). Tighten using a hex head bolt (25) and a nylon nut (39).

3. Draw the cable (65) downwards and around the pulley (49). Attach the pulley (49) with the bracket (17) on both sides – tighten using a hex head bolt (25) and a nylon nut (39).
4. Draw the cable (65) upwards and around the pulley (49). Attach the pulley (49) to bracket B – tighten using a hex head bolt (25) and a nylon nut (39). Refer to the ‘Step F’ diagram.
5. Draw the cable (65) downwards between the two guiding tubes (07), then fully thread the bolt on the end of the cable (65) into the top opening of the select bar (19).
6. Attach the lat bar (12) to the front end of the cable (65), then connect using the hook (62).

Step G:

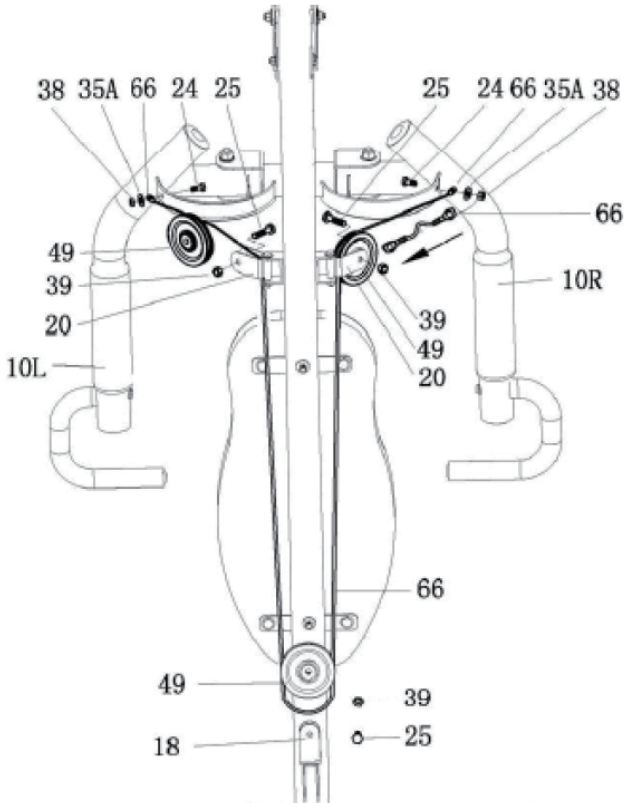

1. Attach one end of the cable for the butterfly arm (66) to the hook on the right butterfly arm (10R) – tighten using a hex head bolt (24), a flat washer (35A) and a nylon nut (38).
2. Feed the cable (66) around the pulley (49), then attach the pulley (49) to the bracket (20) on the right side of the upright support tube (05) – tighten using a hex head bolt (25) and a nylon bolt (39).
3. Feed the other end of the cable (66) downward and around the pulley (49). Attach the pulley (49) to the upper part of the two-way bracket (18) – tighten using a hex head bolt (25) and a nylon nut (39).

4. Feed the cable (66) upward and around the pulley (49). Attach pulley (49) to the bracket (20) on the left side of the upright support tube (05) – tighten using a hex head bolt (25) and a nylon nut (39).

5. Attach the end of the cable (66) to the hook on the left butterfly arm (10L) – tighten using a hex head bolt (24), flat washer (35A) and nylon nut (38).

Step H:

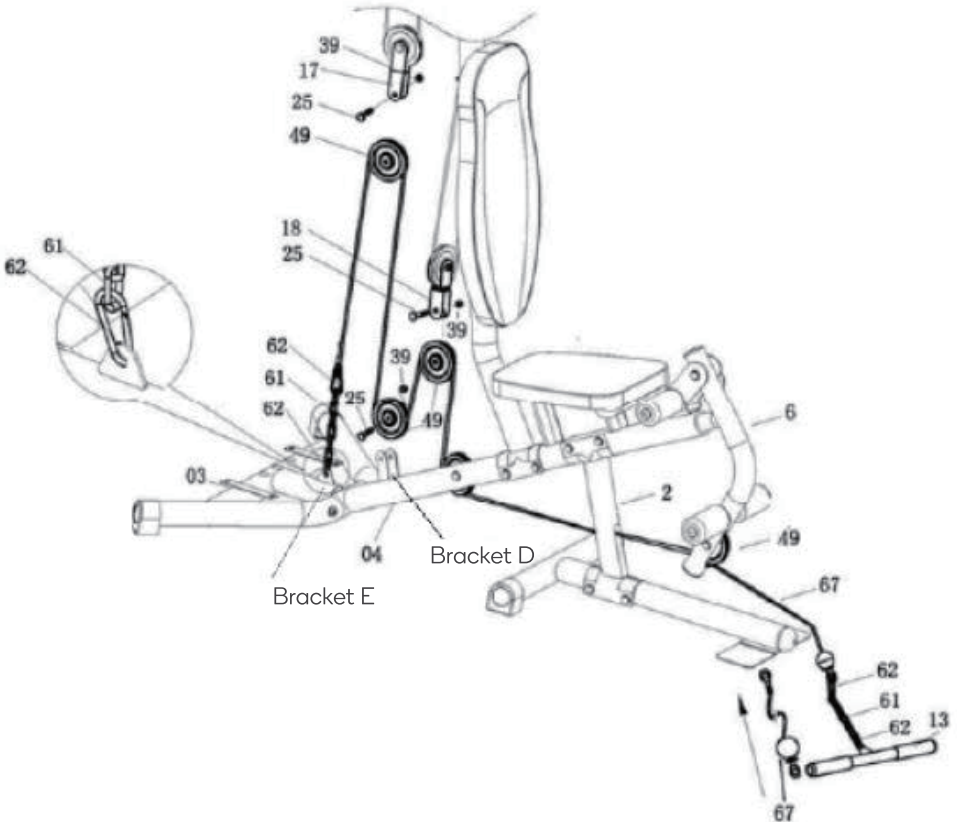

1. Attach the end with the stopper ball of the cable for the lower pull bar (67) to the open bracket leg curl (6), around the underside of the pulley (49).

Feed the cable (67) through the opening on the lower part of the seat post (02), around the pulley (49) from the underside. Draw the cable (67) upward and around the upper side of the pulley (49). Attach the pulley (49) to the underside of the two-way bracket (18) – tighten using a hex head bolt (25) and a nylon nut (39).

2. Feed the cable (67) downward and around the underside of the pulley (49). Attach the pulley (49) to bracket D on the seat post tube (4) – tighten using a hex head bolt (25) and nylon nut (39).

3. Draw the cable (67) upward and around the upper side of the pulley (49). Attach the pulley (49) to the underside of the bracket (17) – tighten using a hex head bolt (25) and a nylon nut (39).

4. Feed the cable (67) downward and connect with bracket E on the rear stabiliser using chain links (61) and a hook (62).

Note: Adjust the cable (67) to be tight, then lock in the desired position of the chain (61) using the hook (62).

5. Attach the lower pull bar (13) to the front end of the cable (67). Connect using the chain links (61) and two hooks (62). Refer to the 'Step G' diagram.

Step I:

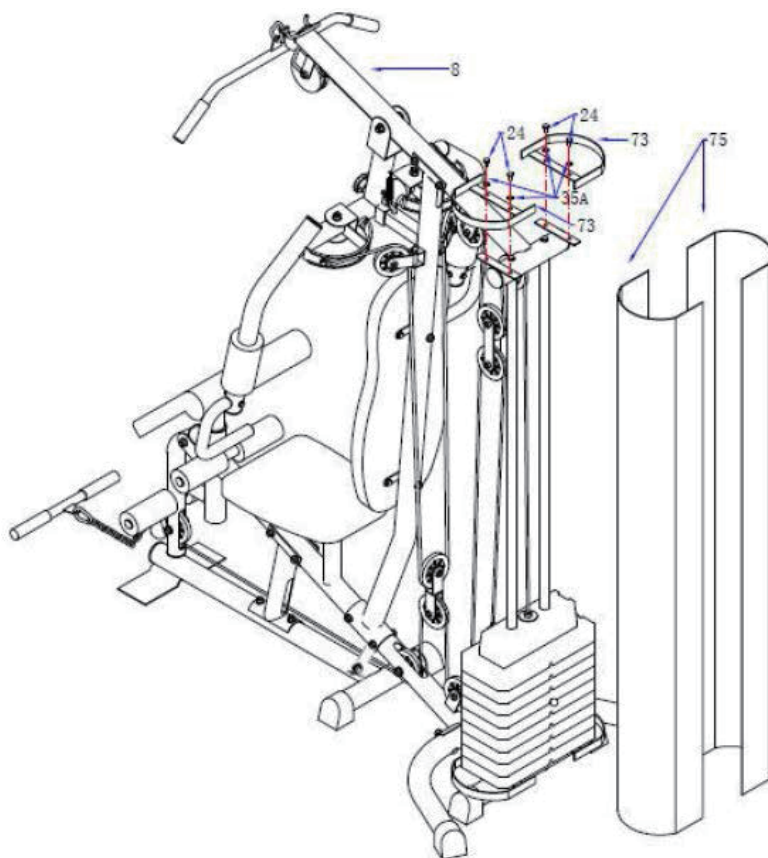

1. Attach the bracket for the cloth cover L (73) to the bridge tube (08)
– tighten using two hex head bolts (24) and two flat washers (35A).

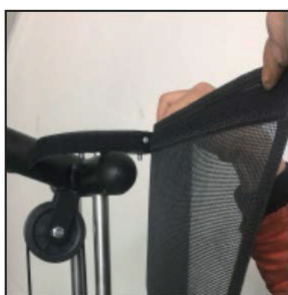

In caso di dubbio, si prega di contattare il
nostro centro assistenza clienti.

I nostri dettagli di contatto sono di seguito:



0039-0249471447



clienti@aosom.it

IMPORTATO DA:

AOSOM Italy srl

Centro Direzionale Milanofiori

Strada 1 Palazzo F1

20057 Assago (MI)

P.I.: 08567220960

FATTO IN CINA