

PawHut

IN230600158V01

D06-188V00

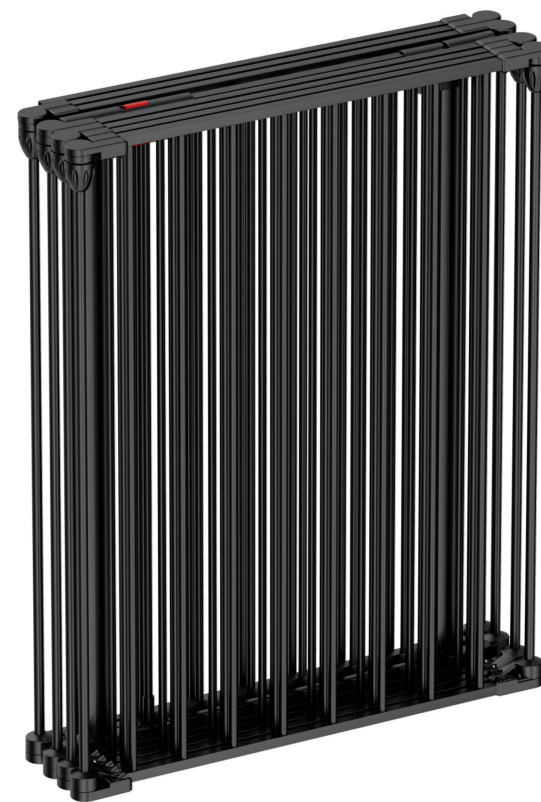

EN_IMPORTANT, RETAIN FOR FUTURE REFERENCE: READ CAREFULLY.

**FR_IMPORTANT: A LIRE ATTENTIVEMENT ET À CONSERVER POUR CONSULTATION
ULTÉRIEURE.**

ES_IMPORTANTE, LEA Y GUARDE PARA FUTURAS REFERENCIAS.

PT_IMPORTANTE, RETER PARA REFERÊNCIA FUTURA: LEIA ATENTAMENTE.

DE_WICHTIG! SORGFÄLTIG LESEN UND FÜR SPÄTER NACHSCHLAGEN AUFBEWAHREN.

**IT_IMPORTANTE! CONSERVARE IL PRESENTE MANUALE PER FUTURO RIFERIMENTO E
LEggerlo ATTENTAMENTE.**

EN**Dear customer,**

Thank you for purchasing this product. So that your appliance serves you well, please read all the instructions in this user's manual. If you have any questions, please contact our customer care center, Our contact details are below:

FR**Cher client,**

Nous vous remercions d'avoir acheté ce produit. Afin que vous puissiez profiter pleinement de votre appareil, veuillez lire toutes les instructions de ce manuel d'utilisation. Si vous avez la moindre question, veuillez contacter notre centre d'assistance à la clientèle, Nos coordonnées sont les suivantes:

DE**Sehr geehrter Kunde,**

Vielen Dank, dass Sie dieses Produkt erworben haben. Damit Ihr Gerät Ihnen gute Dienste leistet, lesen Sie bitte alle Hinweise in diesem Benutzerhandbuch. Wenn Sie Fragen haben, wenden Sie sich bitte an unser Kundendienstzentrum, Unsere Kontaktdaten stehen unten:

ES**Queridos clientes,**

Gracias por comprar este producto. Para que su electrodoméstico le sirva mejor, lea todas las instrucciones de este manual del usuario. Si tiene alguna pregunta, comuníquese con nuestro Centro de Atención al Cliente, Nuestros datos de contacto son los siguientes:

PT**Caros clientes,**

Obrigado por adquirir este produto. Para que o seu aparelho o sirva melhor, leia todas as instruções deste manual do utilizador. Se tiver alguma dúvida, por favor contacte o nosso Centro de Atendimento ao Cliente, Os nossos dados de contacto são os seguintes:

IT**Caro Cliente,**

Grazie per aver acquistato questo prodotto. Per servirvi meglio con questo apparecchio ti prego di leggere tutte le istruzioni in presente manuale utente. In caso di dubbio, si prega di contattare il nostro centro assistenza clienti, I nostri dettagli di contatto sono di seguito:

Country	Phone	Email
US	001-877-644-9366	customerservice@aosom.com
CA	416-792-6088	customerservice@aosom.ca
UK	0044-800-240-4004	enquiries@mhstar.co.uk
DE	0049-0(40)-88307530	service@aosom.de
FR	0033-1-84166106	aosom@mhfrance.fr
ES	0034-931294512	atencioncliente@aosom.es
PT	0034-931294512	info@aosom.pt
IT	0039-0249471447	clienti@aosom.it

US

Imported by Aosom LLC
27150 SW Kinsman Rd Wilsonville, OR 97070 USA
MADE IN CHINA

CA

Imported by Aosom Canada Inc.
7270 Woodbine Avenue, Unit 307, Markham, Ontario Canada
L3R 4B9
MADE IN CHINA

Importé par Aosom Canada Inc.
7270 Woodbine Avenue, unité 307, Markham, Ontario Canada
L3R 4B9
Fabriqué en Chine

UK

IMPORTER ADDRESS:
MH STAR UK LTD
Unit 27, Perivale Park,
Horsenden lane South
Perivale, UB6 7RH
MADE IN CHINA

FR

ADRESSE D'IMPORTATION:
MH FRANCE
2 Rue Maurice Hartmann
92130 Issy Les Moulineaux
France
FABRIQUÉ EN CHINE

ES

IMPORTADOR:
SPANISH AOSOM, S.L.
C/ROC GROS, N°15.08550, ELS HOSTALET DE BALENYÀ, SPAIN.
B66295775
WWW.AOSOM.ES
ATENCIONCLIENTE@AOSOM.ES
TEL: 931294512
HECHO EN CHINA

PT

SPANISH AOSOM, S.L
C.ROC GROS N.15, 08550. ELS HOSTALET DE BALENYÀ
TEL: 931294512 (SEG-SEX DAS 7:30H ÀS 16:30H)
INFO@AOSOM.PT
WWW.AOSOM.PT

DE

ADRESSE DES IMPORTEURS:
MH Handel GmbH
Wendenstraße 309
D-20537 Hamburg
Germany
IN CHINA HERGESTELLT

IT

IMPORTATO DA:
AOSOM Italy srl
Centro Direzionale Milanofiori
Strada 1 Palazzo F1
20057 Assago (MI)
P.I.: 08567220960
FATTO IN CINA

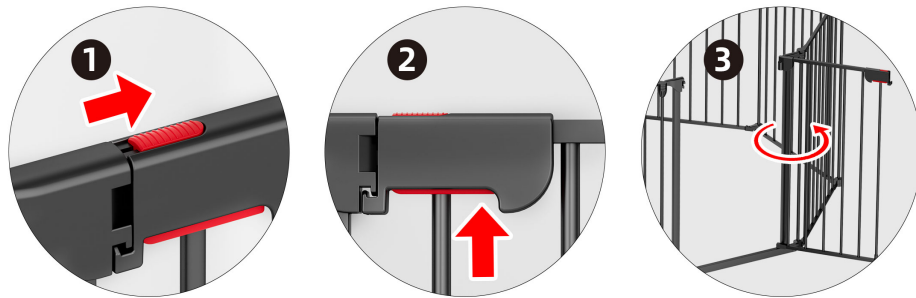
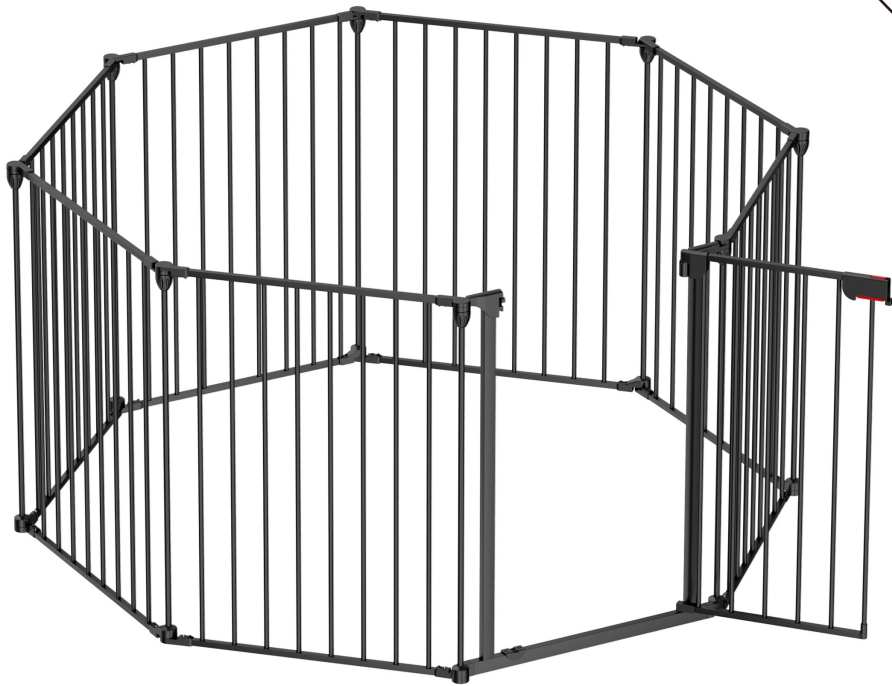
**EN****Before You Start**

Please read all instructions carefully.
 Retain instructions for future reference.
 Separate and count all parts and hardware.
 Read through each step carefully and follow the proper order.
 We recommend that, where possible, all items are assembled near to the area in which they will be placed in use, to avoid moving the product unnecessarily once assembled.
 Always place the product on a flat, steady and stable surface.
 Keep all small parts and packaging materials for this product away from babies and children as they potentially pose a serious choking hazard.

FR**Avant de Commencer**

Veillez lire attentivement toutes les instructions.
 Conservez les instructions pour vous y référer ultérieurement.
 Vérifiez toutes les pièces et les accessoires.
 Lisez attentivement chaque étape et suivez l'ordre correct.
 Nous recommandons que, dans la mesure du possible, tous les produits soient assemblés à proximité de la zone où ils seront utilisés, afin d'éviter tout déplacement inutile du produit une fois assemblé.
 Placez toujours le produit sur une surface plane et stable.
 Conservez toutes les petites pièces de ce produit et les matériaux d'emballage hors de portée des bébés et des enfants, car ils pourraient présenter un risque d'étouffement.

ES**Antes de Empezar**

Lea atentamente todas las instrucciones.
 Conserve las instrucciones para futuras consultas.
 Separe y cuente todas las piezas y los accesorios.
 Lea detenidamente cada paso y siga el orden correcto.
 Recomendamos que, siempre que sea posible, todos los elementos se monten cerca de la zona en la que se van a utilizar, para evitar mover el producto innecesariamente una vez montado.
 Coloque siempre el producto sobre una superficie plana, estable y firme.
 Mantenga todas las piezas pequeñas y los materiales de embalaje de este producto lejos de los bebés y los niños, ya que pueden representar un grave riesgo de asfixia.

PT**Antes de começar**

Leia atentamente todas as instruções.
 Guarde as instruções para referência futura.
 Separe e conte todas as peças e ferragens.
 Leia atentamente cada passo e siga a ordem correcta.
 Recomendamos que, sempre que possível, todos os itens sejam montados perto da área em que serão utilizados, para evitar deslocar desnecessariamente o produto depois de montado.
 Coloque sempre o produto numa superfície plana, firme e estável.
 Mantenha todas as peças pequenas e materiais de embalagem deste produto afastados de bebés e crianças, uma vez que podem representar um risco grave de asfixia.

Vor dem Beginnen







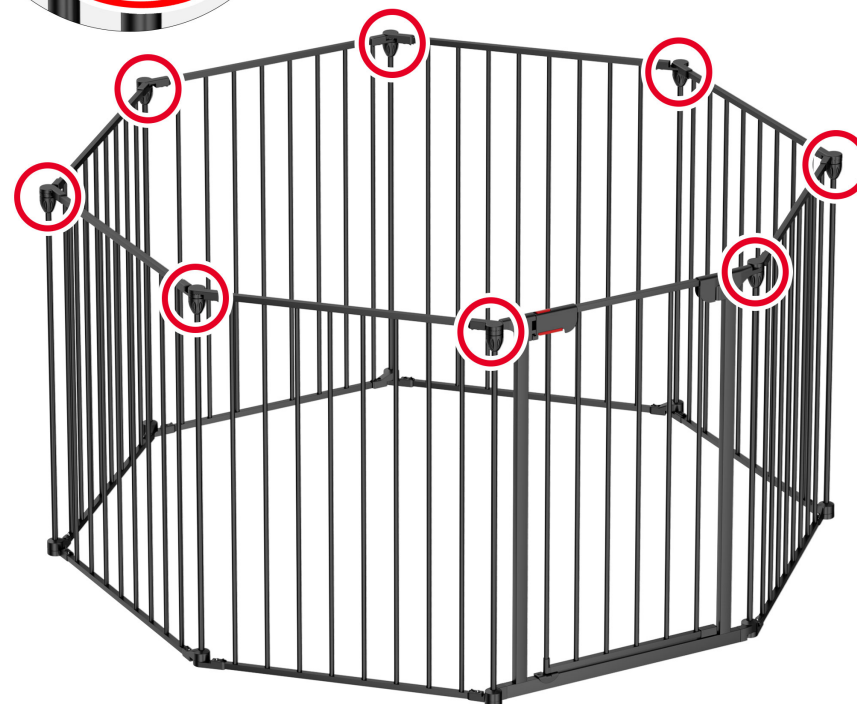

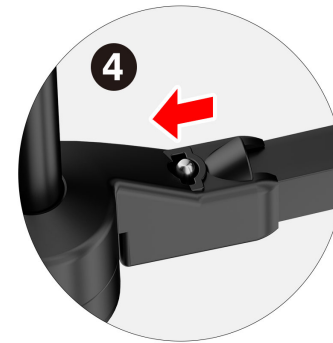
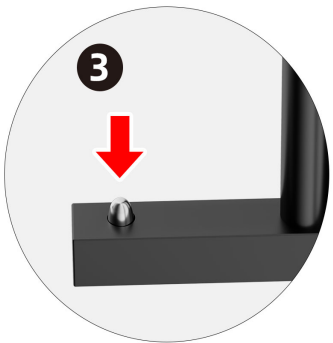
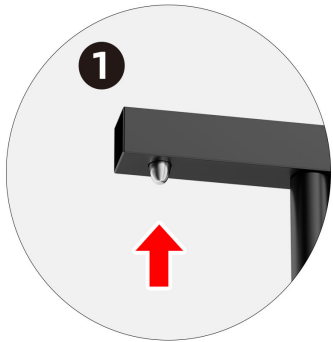
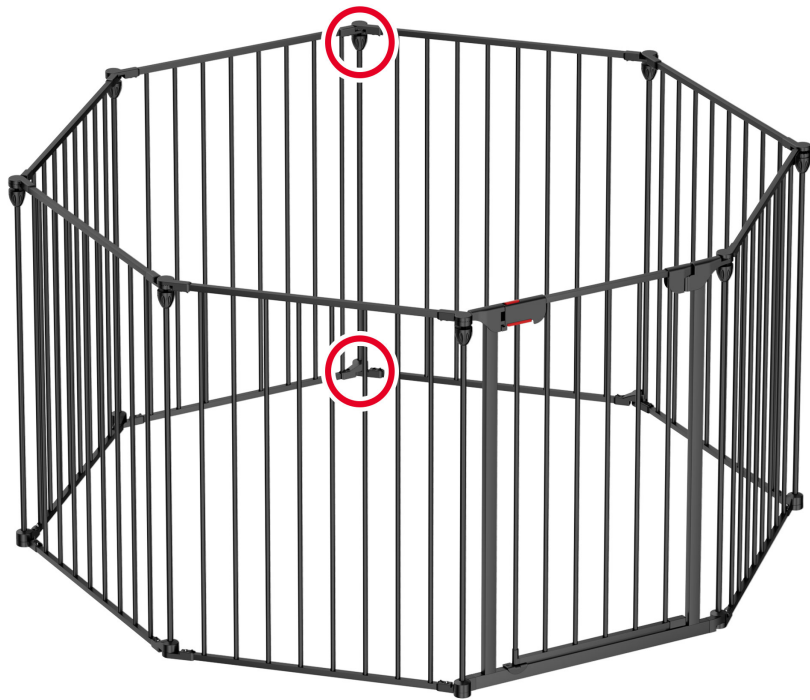
Bitte lesen Sie alle Anweisungen sorgfältig durch.
 Bewahren Sie die Anweisungen zum zukünftigen Verwendung auf.
 Überprüfen Sie, ob alle Teile und Zubehörteile vorhanden sind.
 Lesen Sie jeden Schritt sorgfältig durch und befolgen Sie die richtige Reihenfolge.
 Wir empfehlen, alle Teile möglichst in der Nähe des Aufstellungsortes zu montieren, um unnötige Bewegungen nach der Montage zu vermeiden.
 Stellen Sie den Artikel immer auf eine ebene, feste und stabile Fläche.
 Halten Sie alle kleinen Teile und Verpackungsmaterialien fern von Babys und Kindern, ansonsten besteht Erstickungsgefahr.

Prima di Iniziare

Si prega di leggere attentamente tutte le istruzioni.
 Conservare le istruzioni per riferimento futuro.
 Separare e contare tutte le parti e gli accessori.
 Leggere attentamente ogni passo e seguire l'ordine corretto.
 Si consiglia, ove possibile, di assemblare tutti gli articoli vicino alla zona in cui verranno posti in uso, per evitare di spostare inutilmente il prodotto una volta assemblato.
 Posizionare sempre il prodotto su una superficie piana, stabile.
 Tenere tutte le piccole parti e i materiali di imballaggio di questo prodotto lontano dalla portata di neonati e bambini, in quanto possono costituire un serio pericolo di soffocamento.





 <p>A X8 Ø 6 +1(Spare)</p>	 <p>B X8 M4X35 +1(Spare)</p>
 <p>C X4</p>	 <p>D X1</p>
 <p>E X2</p>	 <p>F X1</p>
 <p>G X1</p>	 <p>H X1</p>

