

Soozier

IN230600299V01_US_CA





A91-120



FR: IMPORTANT : A LIRE ATTENTIVEMENT ET À CONSERVER POUR CONSULTATION ULTÉRIEURE.

EN: IMPORTANT, RETAIN FOR FUTURE REFERENCE: READ CAREFULLY.

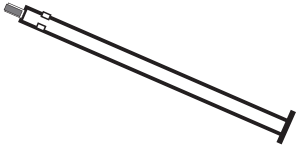
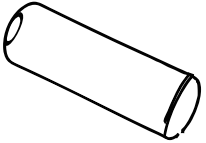
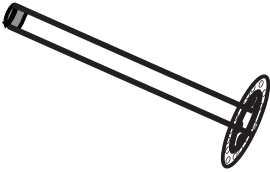
BOX-1/2

NO.	PARTS	QTY
A		2
B		1
C		1
D		1
E		1
H		1
 Hardware		

BOX-2/2

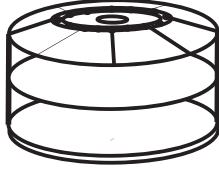
NO.	PARTS	QTY
F		1

	A x 2		E x 1		I x 15
	B x 1		F x 1		J x 1
	C x 1		G x 12		K x 2
	D x 1		H x 1		L x 1
					N x 1

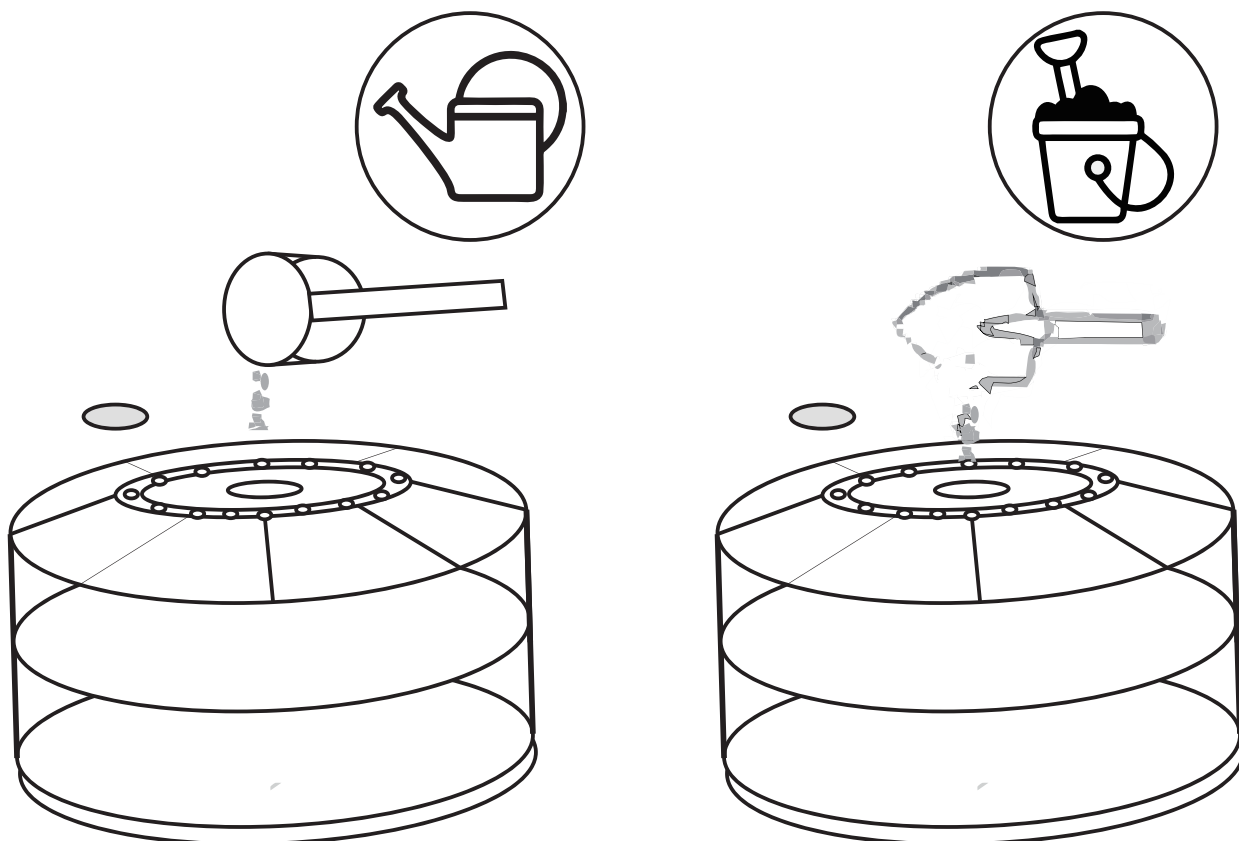

EN: Fill the base(F) with water or sand replacethe cap.

FR: Remplissez la base (F) d'eau ou de sable et remettez le bouchon en place.

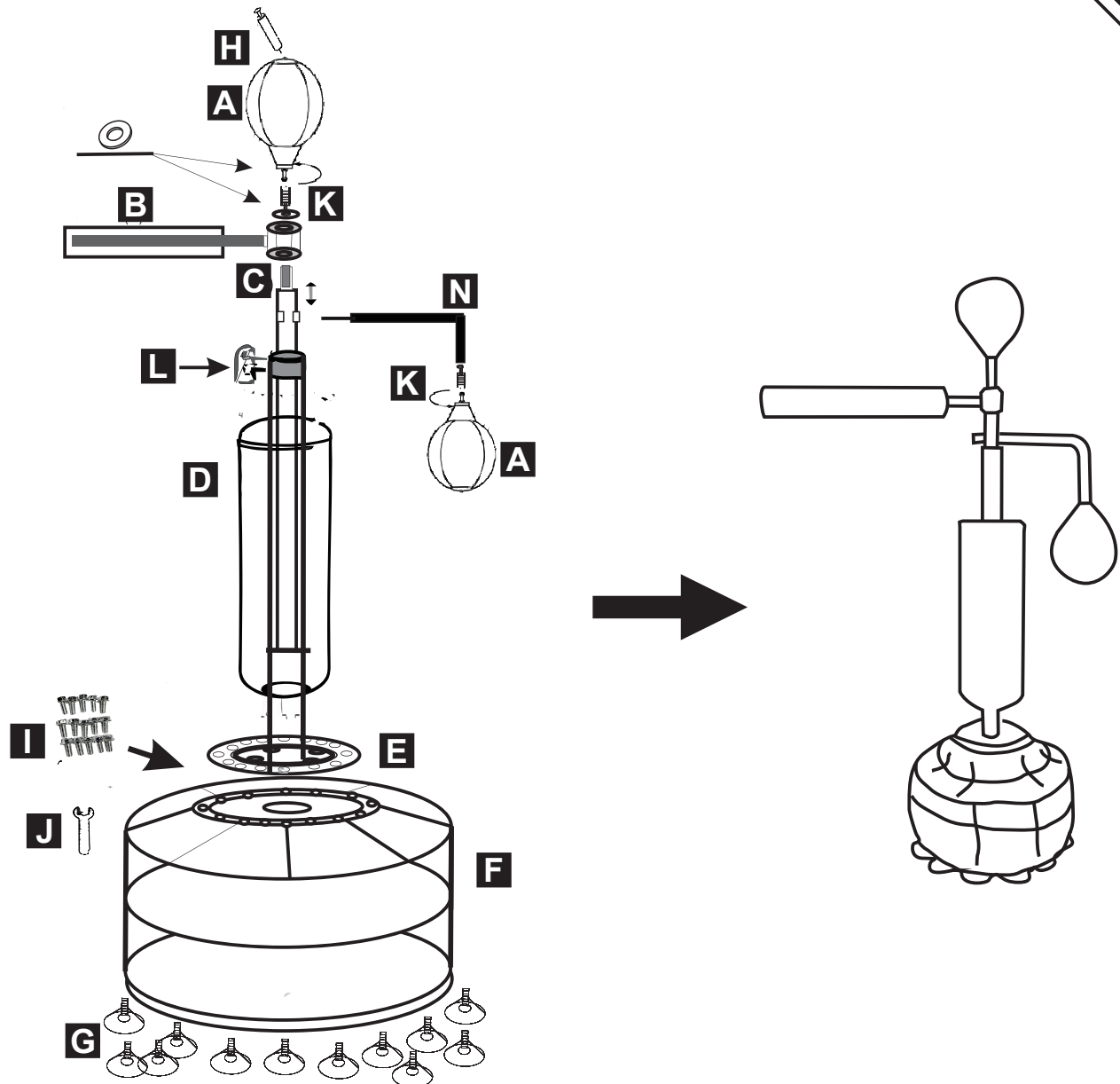
**EN:**

1. Install the suction cup (G) on the bottom of the base (F)
2. Fix the connector (E) on base (F) with the wrench (J) and the Screw (I)
3. Insert the upper section (C) into the Percussion body (D) and set to the desired height. use the butterfly screw to fix the upper section into place.
4. Install the rotating rod (B) on the upper end of the adjusting rod (C), Install the pipe fitting (N) onto the main rod (C) and fix it
5. Put the washer on top of adjusting rod (C) and install the spring (K)
6. Pump up the punch ball by using the pump (H) provided, then screw into position at the top of the Spring (K)
7. Only use a safe place, well away from all obstacles, breakable items or other hazards.

Boxing is a contact sport. Any contact can be dangerous and result in serious injury. When boxing, be sure you are in good physical condition and under expert supervision. This equipment will provide limited protection but will not protect you against serious injury. Anyone using this equipment must assume the risk of any injury.

FR:

1. Installez la ventouse (G) sur le fond de la base (F).
 2. Fixez le connecteur (E) sur la base (F) avec la clé (J) et la vis (I).
 3. Insérez la section supérieure (C) dans le corps de percussion (D) et réglez-la à la hauteur désirée. Fixez la section supérieure en place à l'aide de la vis papillon.
 4. Fixez la tige rotative (B) sur l'extrémité supérieure de la tige de réglage (C), fixez le raccord de tuyau (N) sur la tige principale (C) et fixez-le.
 5. Mettez la rondelle sur le dessus de la tige de réglage (C) et fixez le ressort (K)
 6. Pompez le ballon de frappe à l'aide de la pompe (H) fournie, puis vissez-le en position en haut du ressort (K).
 7. N'utilisez ce produit que dans un endroit sûr, toujours éloigné de tout obstacle, objet cassable ou autre danger.
- La boxe est un sport de contact, tout contact peut être dangereux et entraîner des blessures graves. Lorsque vous pratiquez la boxe, assurez-vous d'être en bonne condition physique et sous la surveillance d'un expert. Cet équipement fournit une protection limitée mais ne vous protège pas contre les blessures graves. Toute personne utilisant cet équipement doit assumer le risque de toute blessure.

US

If you have any questions, please contact our customer care center.
Our contact details are below:



001-877-644-9366



customerservice@aosom.com

Imported by Aosom LLC
27150 SW Kinsman Rd Wilsonville, OR 97070 USA
MADE IN CHINA

CA

If you have any questions, please contact our customer care center.
Our contact details are below:

Si vous avez la moindre question, veuillez contacter notre centre d'assistance à la clientèle.
Nos coordonnées sont les suivantes:



416-792-6088



customerservice@aosom.ca

Imported by Aosom Canada Inc.
7270 Woodbine Avenue, Unit 307, Markham, Ontario Canada L3R 4B9
MADE IN CHINA

Importé par Aosom Canada Inc.
7270 Woodbine Avenue, unité 307, Markham, Ontario Canada L3R 4B9
Fabriqué en Chine