

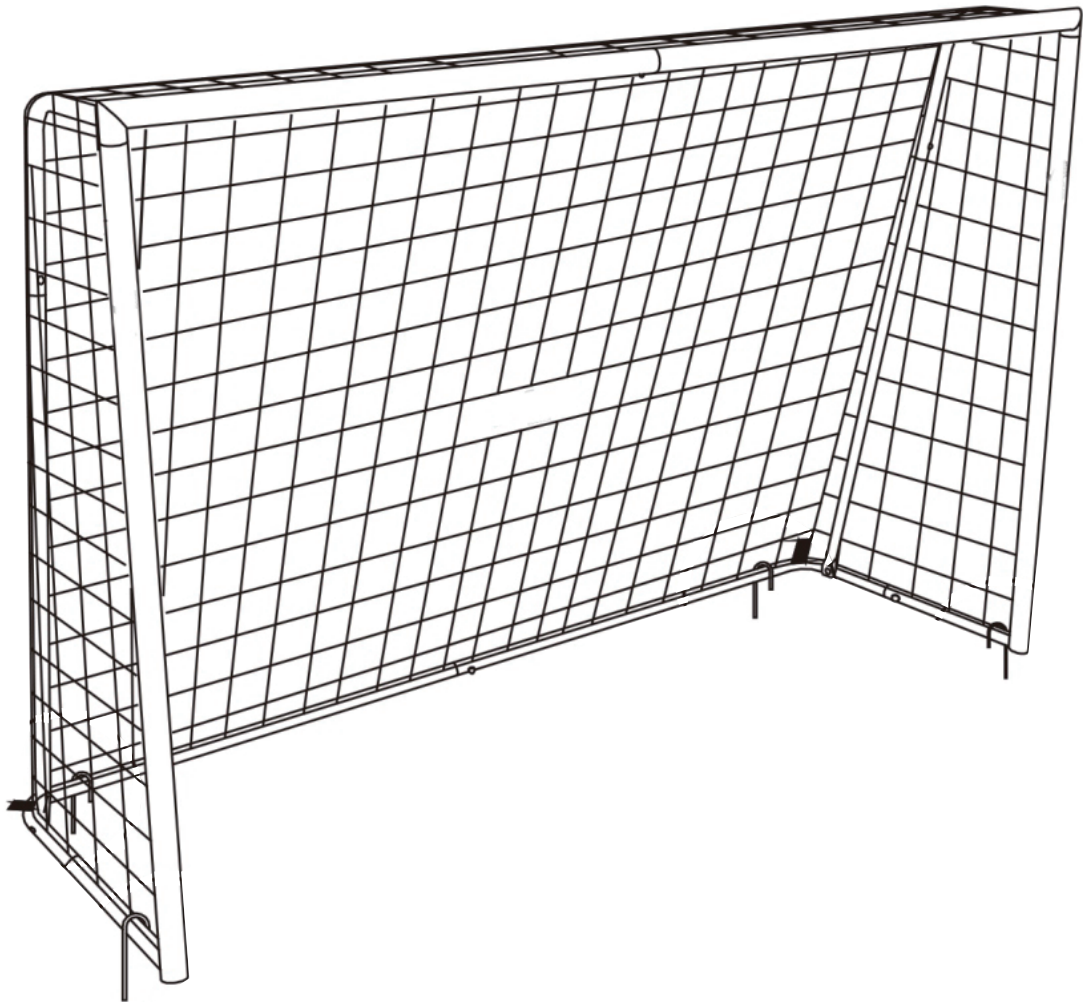

IN230600541V02_UK_FR_IT_ES

A62-022_A62-022V00













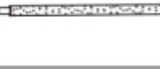





EN



IMPORTANT, RETAIN FOR FUTURE REFERENCE: READ CAREFULLY

ASSEMBLY INSTRUCTIONS

List of parts, materials, and tools:

PART NO.	DIAGRAM	QTY
1		1
2		1
3		1
4		1
5		1
6		1
7		2
8		2
9		1
10		18
11		2
12		2
13		2
14		2
15		4
16		2
17		1
18		1

Assembly instructions:

Step 1

Please connect the top bar #1 and the top bar #2 together.

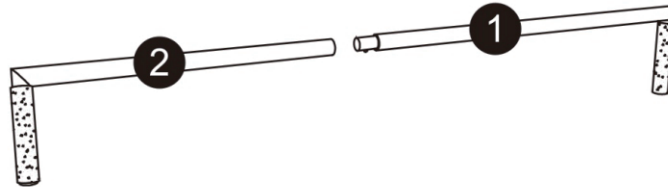

Step 2

Please connect the right post #3 to the top bar #1 and the left post #4 to the top bar #2.

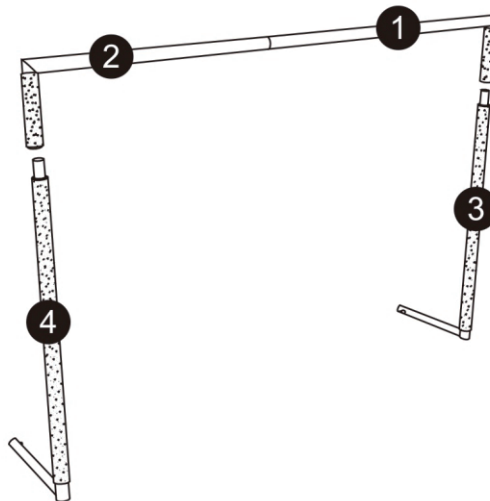

Step 3

Please connect the base tubes #5 and #6 together; then insert them into the tubes #3 and #4.

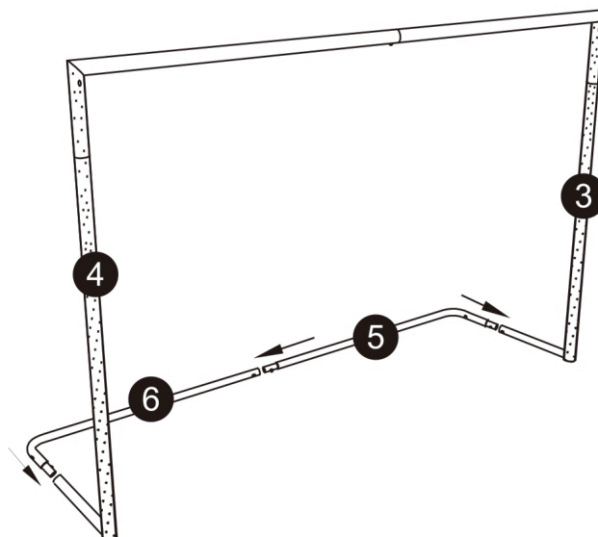

Assembly instructions:

Step 4

Connect curved tube #7 and rear support tube #8 together. Attach the upper end to the top bar #1 using bolt #13 and Allen wrench #18. Secure the lower end to the right base tube #5 and use bolt #12, washer #16, nut #14, Allen wrench #18, and wrench #17 as shown in the enlarged diagram. Repeat the same process on the other side.

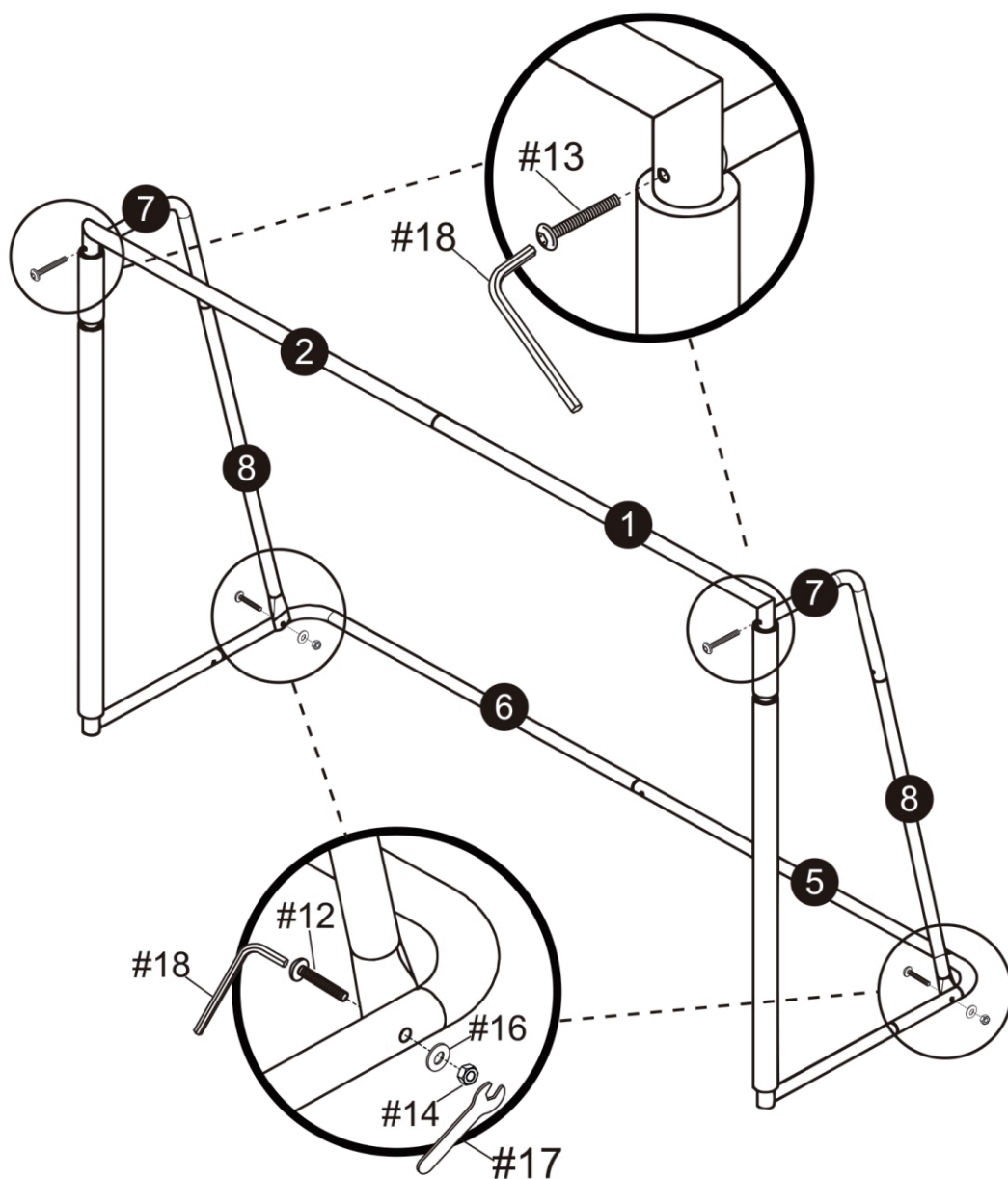

Assembly instructions:

Step 5

Please drape net #9 over the soccer goal. The red tabs on the net should be located in the lower corners of the goal. Secure the net to the goal frame on all sides using the provided straps #10. For the left and right posts #3 and #4, attach the foam protective cover #11. Spread the 18 hook and loop straps evenly along the goal frame to the left post #3 and right post #4.

Note: The logo should face towards the goal opening.

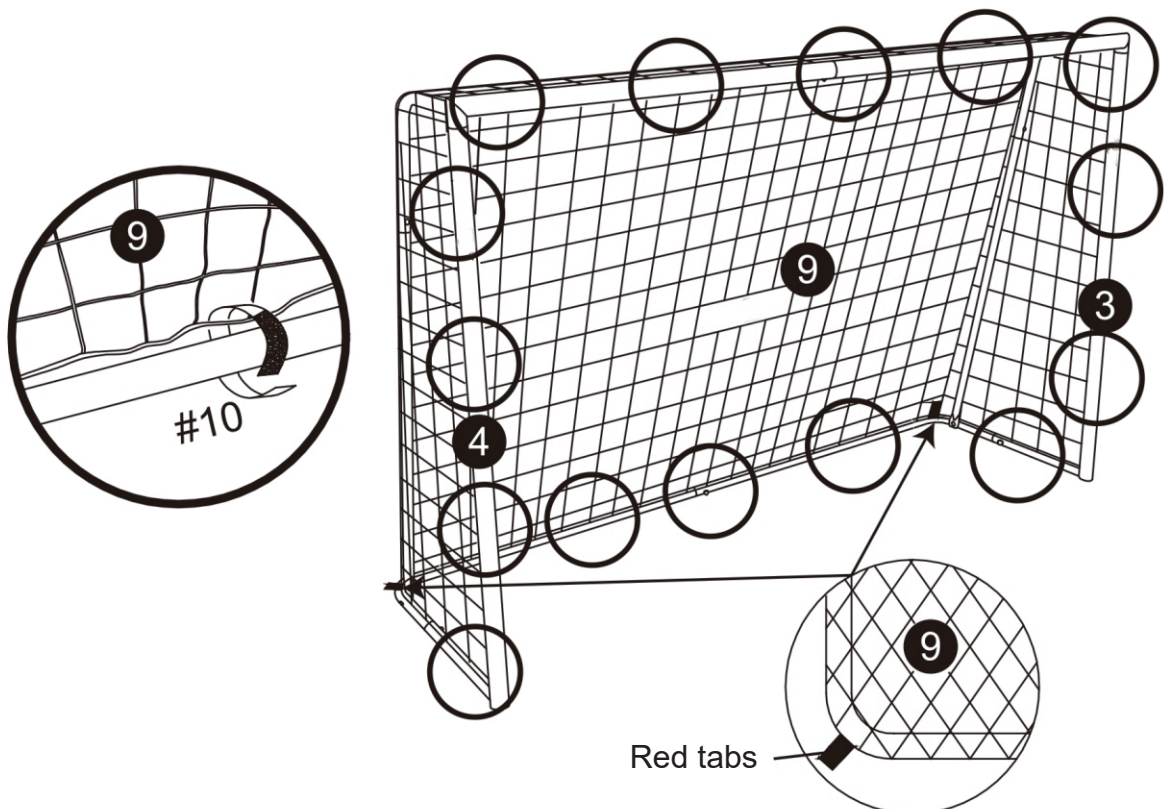

Assembly instructions:

Step 6

Insert the "J" shaped stakes #15 into the ground at all four corners.

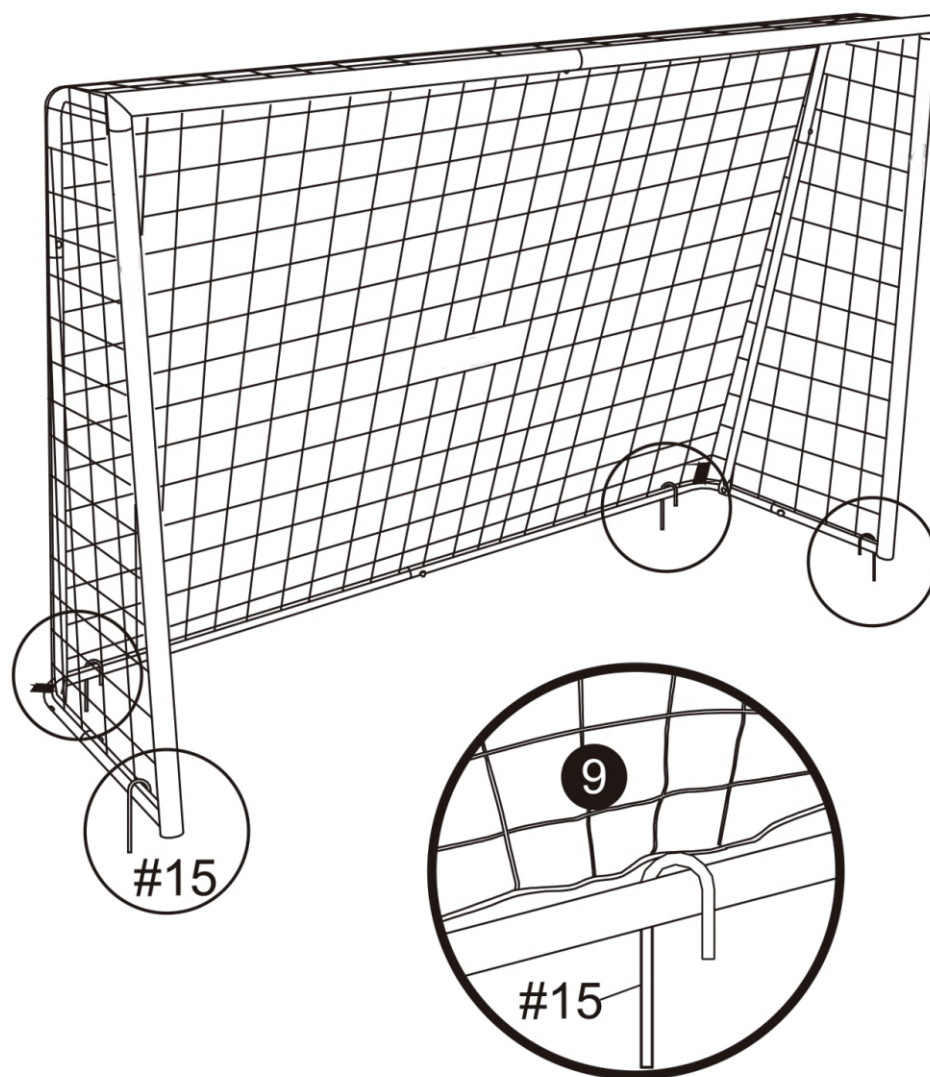

Warning:

- * When assembling, it is recommended to wear safety goggles to protect your eyes.
- * Children should be supervised when playing with this equipment.
- * Only use this product on flat and even surfaces - do not place it on stairs or slopes.
- * For outdoor use only.
- * Keep the equipment at least 8 feet away from objects such as fences, garages, houses, clotheslines, overhead branches, and electrical wires.
- * Use common sense when playing with this product.
- * This product is stable - it remains balanced during use.
- * Do not stand behind the net (or in the path of the kicked ball) to avoid being hit by the ball.
- * Do not stand on this equipment - it may damage it and cause injury.
- * Do not use this product as a bungee jump or for any purposes other than those described in this manual.



IN230600541V02_UK_FR_IT_ES

A62-022_A62-022V00



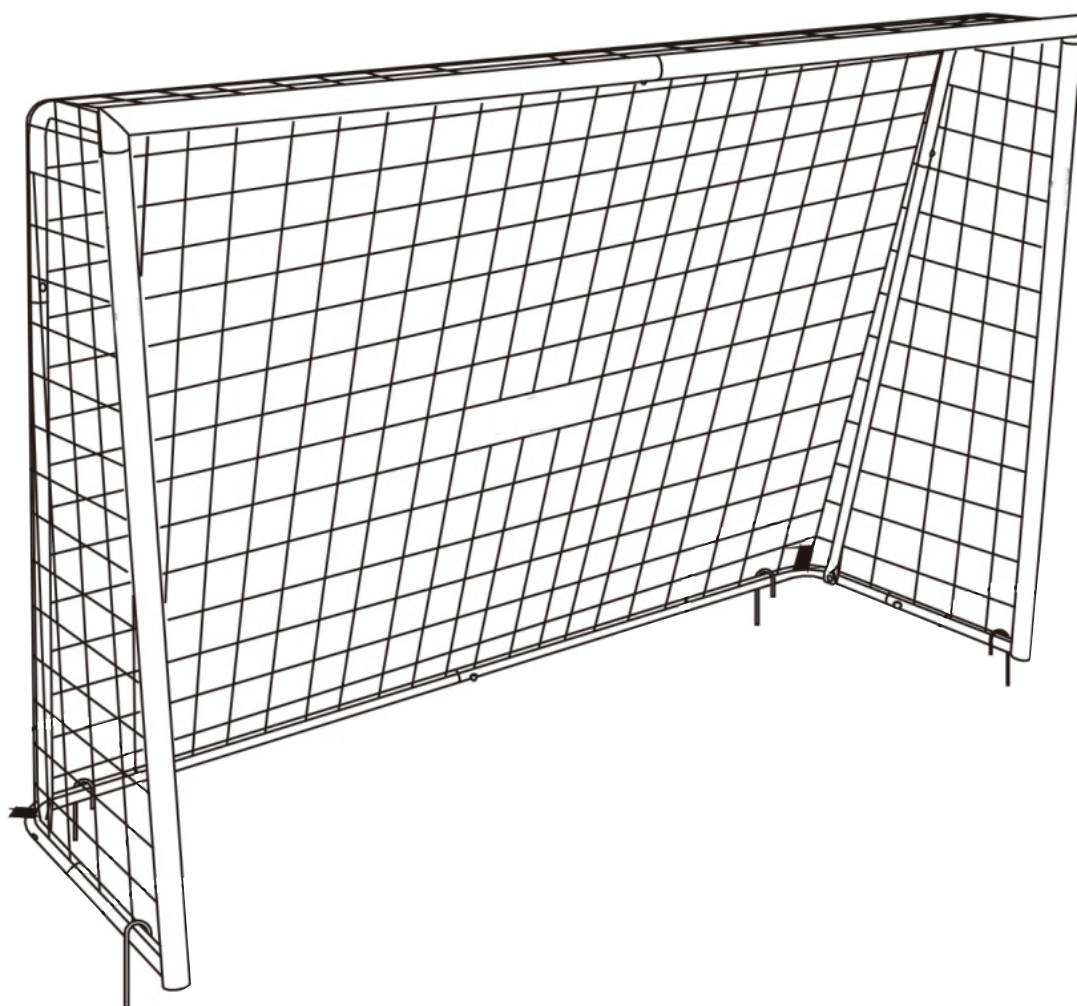















FR



IMPORTANT - CONSERVEZ CES INFORMATIONS
POUR VOTRE CONSULTATION ULTÉRIEURE: LISEZ ATTENTIVEMENT

INSTRUCTIONS D'ASSEMBLAGE

Liste des pièces, du matériel et des outils:

PARTIE NO.	DIAGRAMME	QUANTITÉ
1		1
2		1
3		1
4		1
5		1
6		1
7		2
8		2
9		1
10		18
11		2
12		2
13		2
14		2
15		4
16		2
17		1
18		1

Instructions de montage:

Étape 1

Veillez connecter la barre supérieure # 1 et la barre supérieure # 2 ensemble.

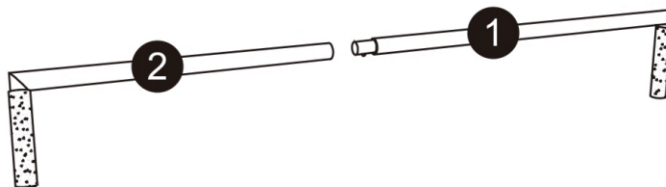

Étape 2

Veillez connecter le poteau droit # 3 à la barre supérieure # 1 et le poteau gauche # 4 à la barre supérieure # 2.

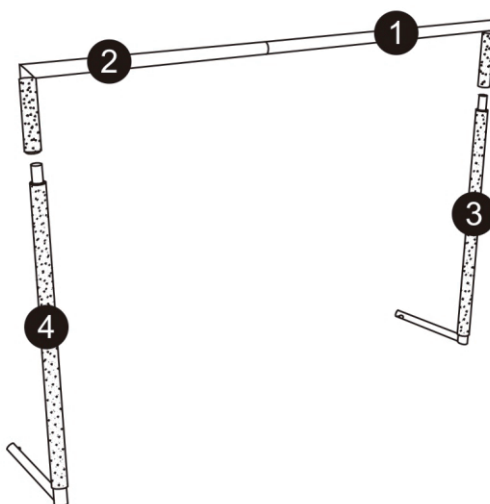

Étape 3

Veillez connecter les tubes de base # 5 et # 6 ensemble ; puis insérez-les dans les tubes # 3 et # 4.

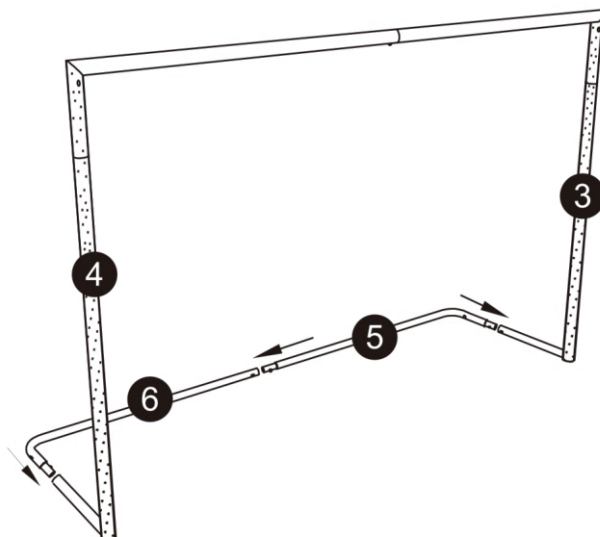

Instructions de montage:

Étape 4

Connectez le tube incurvé # 7 et le tube de support arrière # 8 ensemble. Fixez l'extrémité supérieure à la barre supérieure n ° 1 à l'aide du boulon # 13 et de la clé Allen # 18. Fixez l'extrémité inférieure au tube de base droit # 5 et utilisez le boulon # 12, la rondelle # 16, l'écrou # 14, la clé Allen # 18 et la clé # 17 comme indiqué sur le schéma agrandi. Répétez de la même manière de l'autre côté.

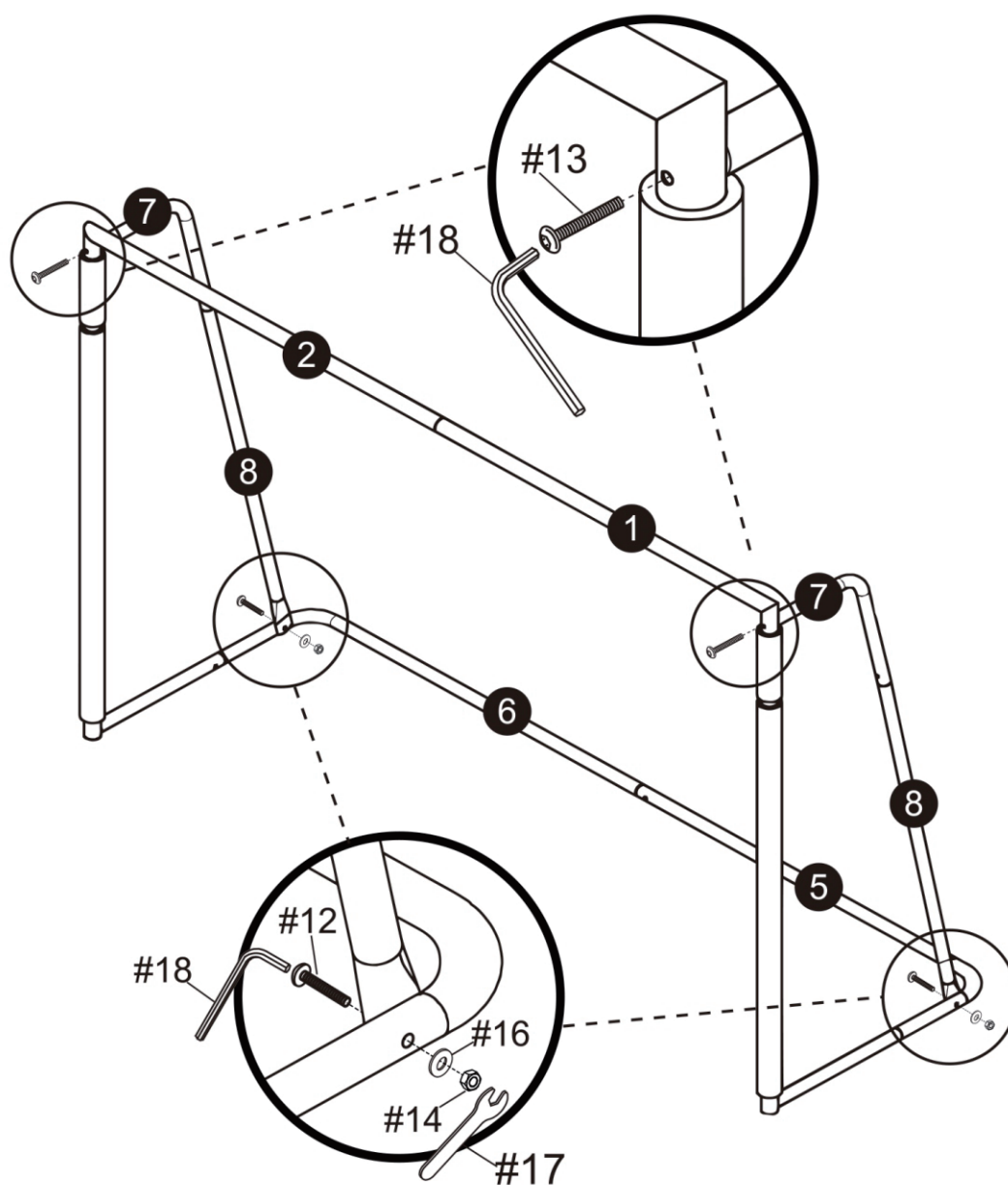

Instructions de montage:

Étape 5

Veillez draper le filet # 9 sur le but de soccer. Les onglets rouges sur le filet doivent être situés dans les coins inférieurs du but.

Veillez fixez le filet au cadre de but de tous les côtés à l'aide des sangles # 10 fournies. Pour les poteaux gauche et droit # 3 et # 4, fixez le couvercle de protection en mousse # 11. Étalez uniformément les 18 sangles auto-agrippantes tout au long du cadre de but jusqu'au poteau gauche n ° 3 et au poteau droit # 4.

Remarque: Le logo doit faire face à l'ouverture du but.

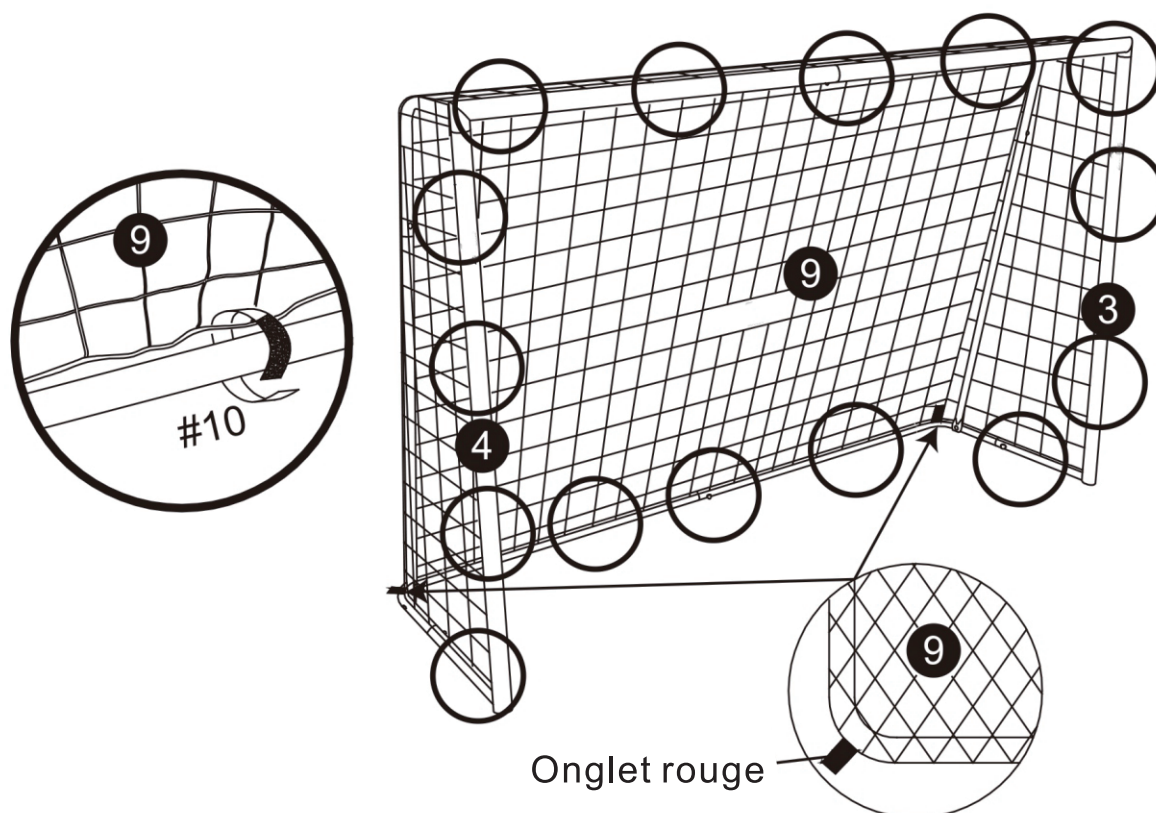

Instructions de montage:

Étape 6

Veillez insérer les piquets en forme de "J" # 15 dans le sol aux quatre coins.

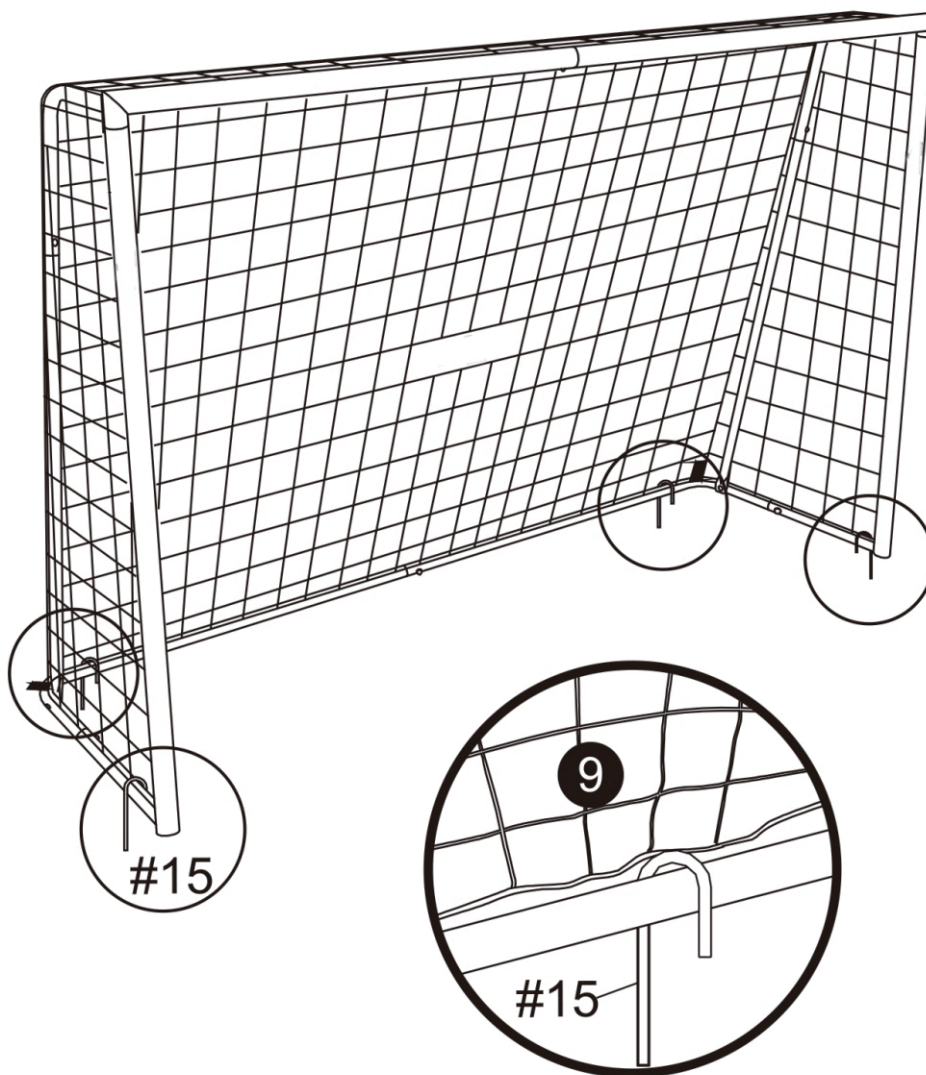

Avertissement :

- * Lors de l'assemblage, il est recommandé de porter des lunettes de sécurité pour protéger vos yeux.
- * Les enfants doivent être surveillés lorsqu'ils jouent avec cet équipement.
- * N'utilisez ce produit que sur des surfaces plates et régulières - ne placez-le pas sur des escaliers ou des pentes.
- * Pour une utilisation en extérieur uniquement.
- * Gardez l'appareil à au moins 8 pieds de distance d'objets tels que les clôtures, les garages, les maisons, les cordes à linge, les branches en surplomb et les fils électriques.
- * Il faut faire preuve de bon sens quand on joue avec ce produit.
- * Ce produit est stable - il reste en équilibre lors de son utilisation.
- * Ne vous tenez pas derrière le filet (ou dans la trajectoire du ballon botté) pour éviter d'être touché par le ballon..
- * Ne vous tenez pas sur cet appareil - cela pourrait l'endommager et causer des blessures.
- * N'utilisez pas ce produit comme un saut à l'élastique ou à d'autres fins, autres que celles décrites dans ce manuel.



IN230600541V02_UK_FR_IT_ES

A62-022_A62-022V00



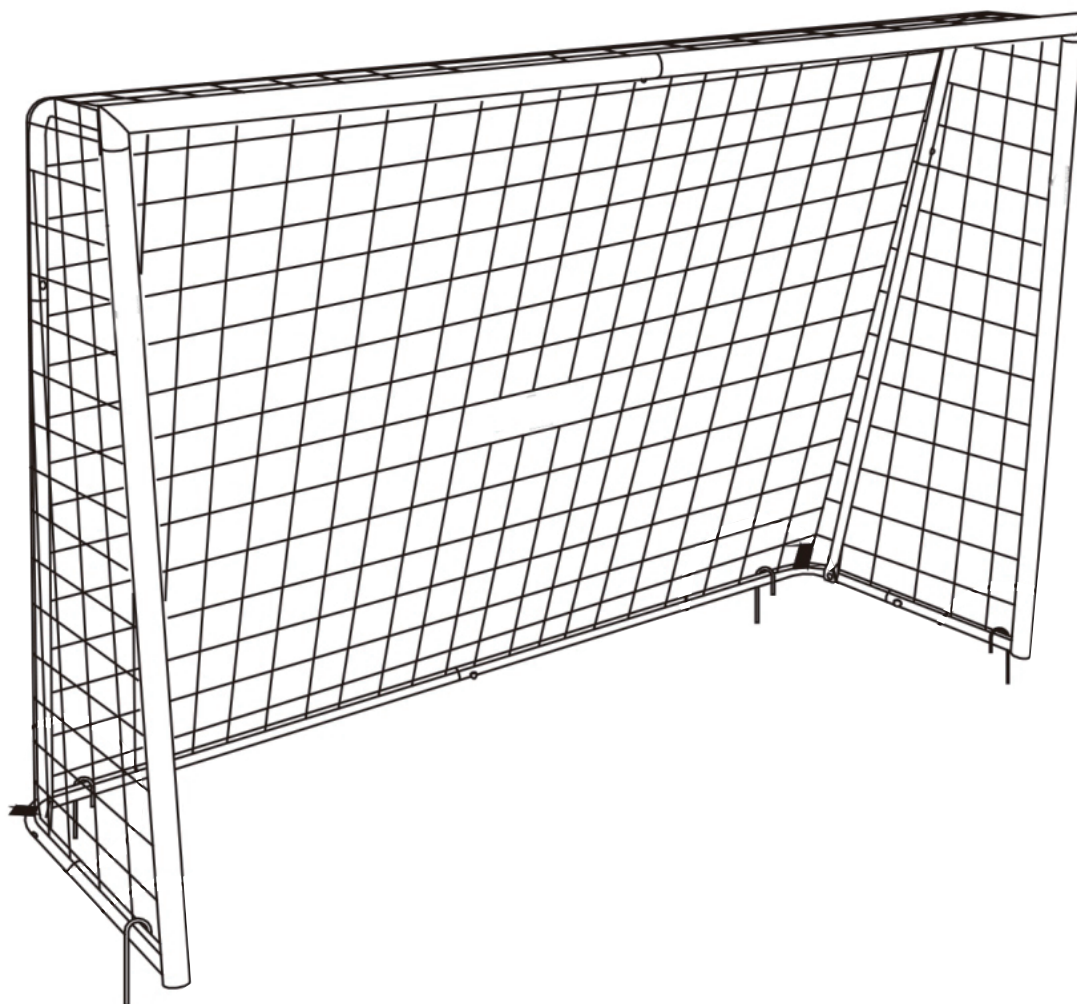









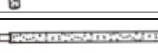



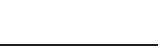

ES



IMPORTANTE - CONSERVE ESTA INFORMACIÓN
PARA SU CONSULTA POSTERIOR: LEER DETALLADAMENTE

INSTRUCCIONES DE MONTAJE

Lista de partes, materiales y herramientas:

N° DE PARTE	DIAGRAMA	CANTIDAD
1		1
2		1
3		1
4		1
5		1
6		1
7		2
8		2
9		1
10		18
11		2
12		2
13		2
14		2
15		4
16		2
17		1
18		1

Instrucciones de ensamblaje:

Paso 1

Por favor, conecte la barra superior #1 y la barra superior #2 juntas.

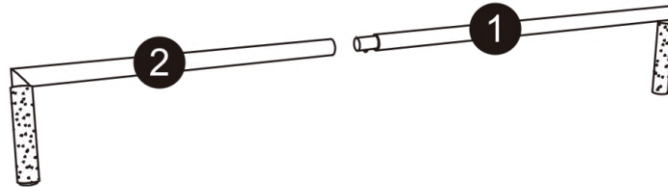

Paso 2

Conecte el poste derecho #3 a la barra superior #1 y el poste izquierdo #4 a la barra superior #2.

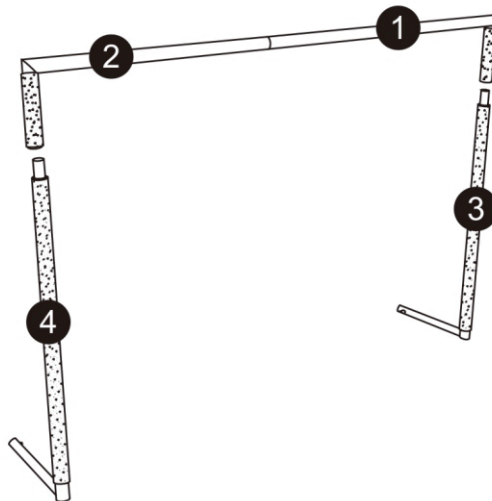

Paso 3

Conecte los tubos de base #5 y #6 juntos; luego insértelos en los tubos #3 y #4.

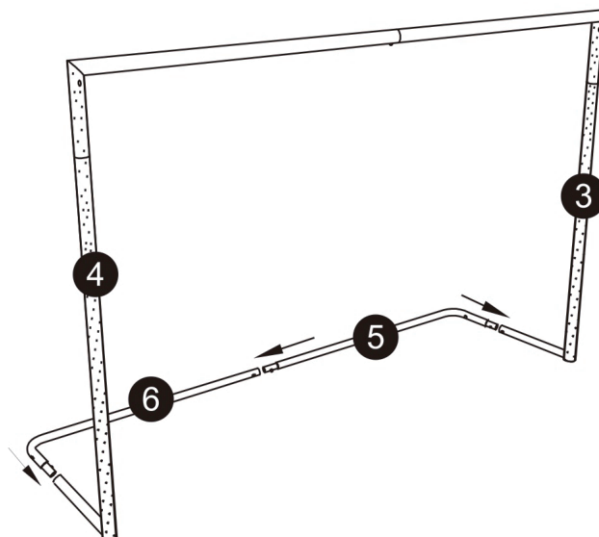

Instrucciones de ensamblaje:

Paso 4

Conecte el tubo curvo #7 y el tubo de soporte trasero #8 juntos. Adjunte el extremo superior a la barra superior #1 utilizando el perno #13 y la llave Allen #18. Fije el extremo inferior al tubo de base derecho #5 y use el perno #12, la arandela #16, la tuerca #14, la llave Allen #18 y la llave #17 como se muestra en el diagrama ampliado. Repita el mismo proceso en el otro lado.

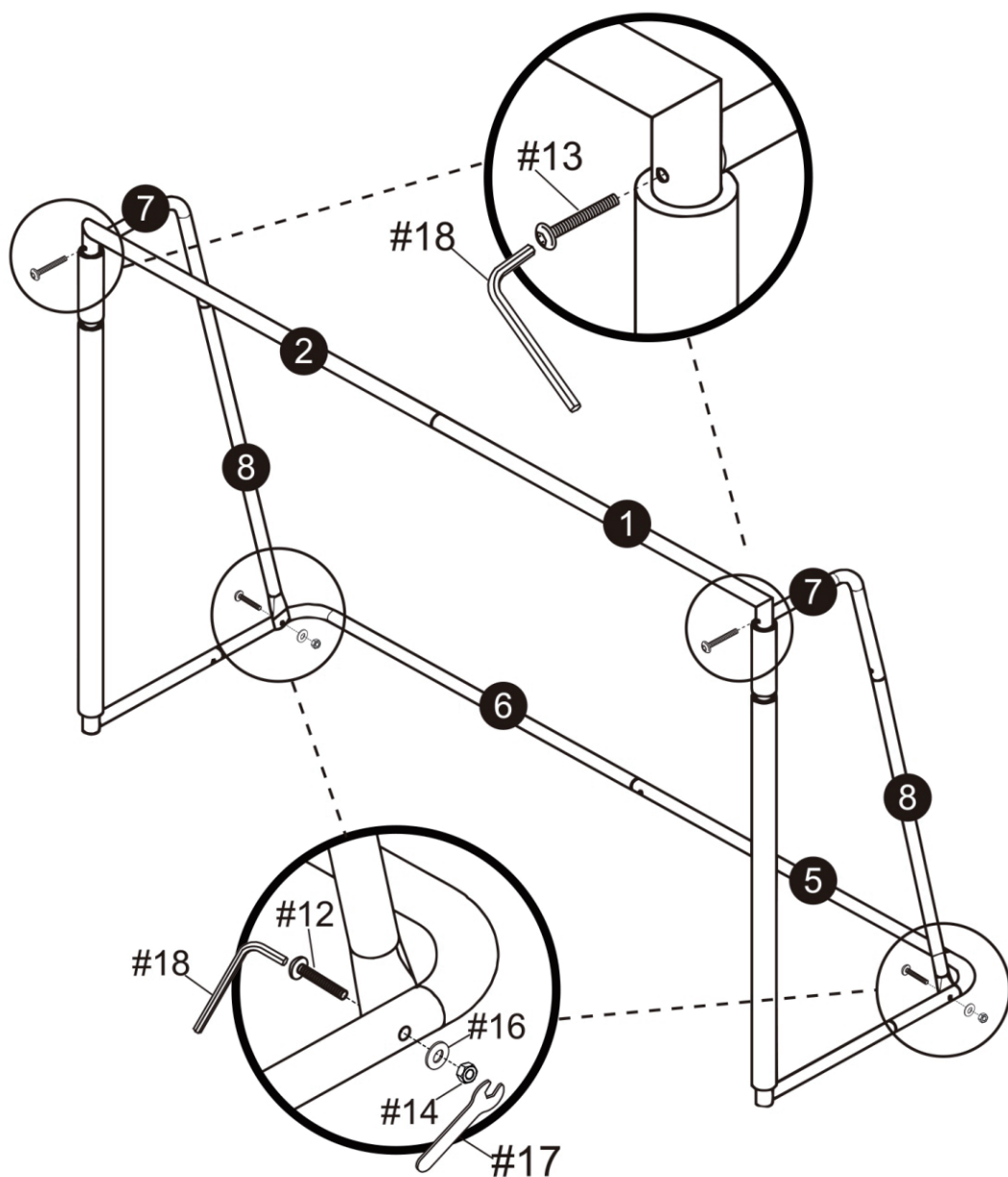

Instrucciones de ensamblaje:

Paso 5

Coloque la red #9 sobre la portería de fútbol. Las pestañas rojas de la red deben estar ubicadas en las esquinas inferiores de la portería. Asegure la red al marco de la portería en todos los lados utilizando las correas proporcionadas #10. Para los postes izquierdo y derecho #3 y #4, coloque la cubierta protectora de espuma #11. Distribuya las 18 correas de gancho y bucle de manera uniforme a lo largo del marco de la portería hasta el poste izquierdo #3 y el poste derecho #4.

Nota: El logotipo debe mirar hacia la abertura de la portería.

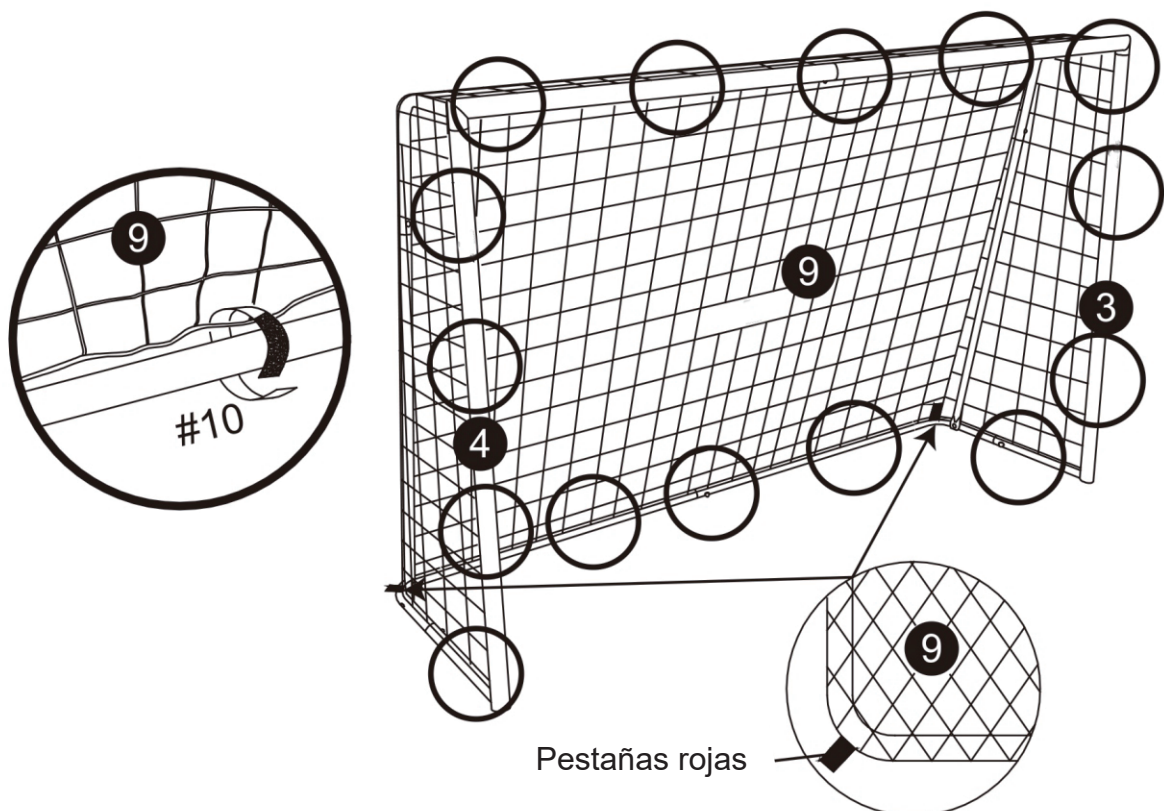

Instrucciones de ensamblaje:

Paso 6

Inserte las estacas en forma de "J" #15 en el suelo en las cuatro esquinas.

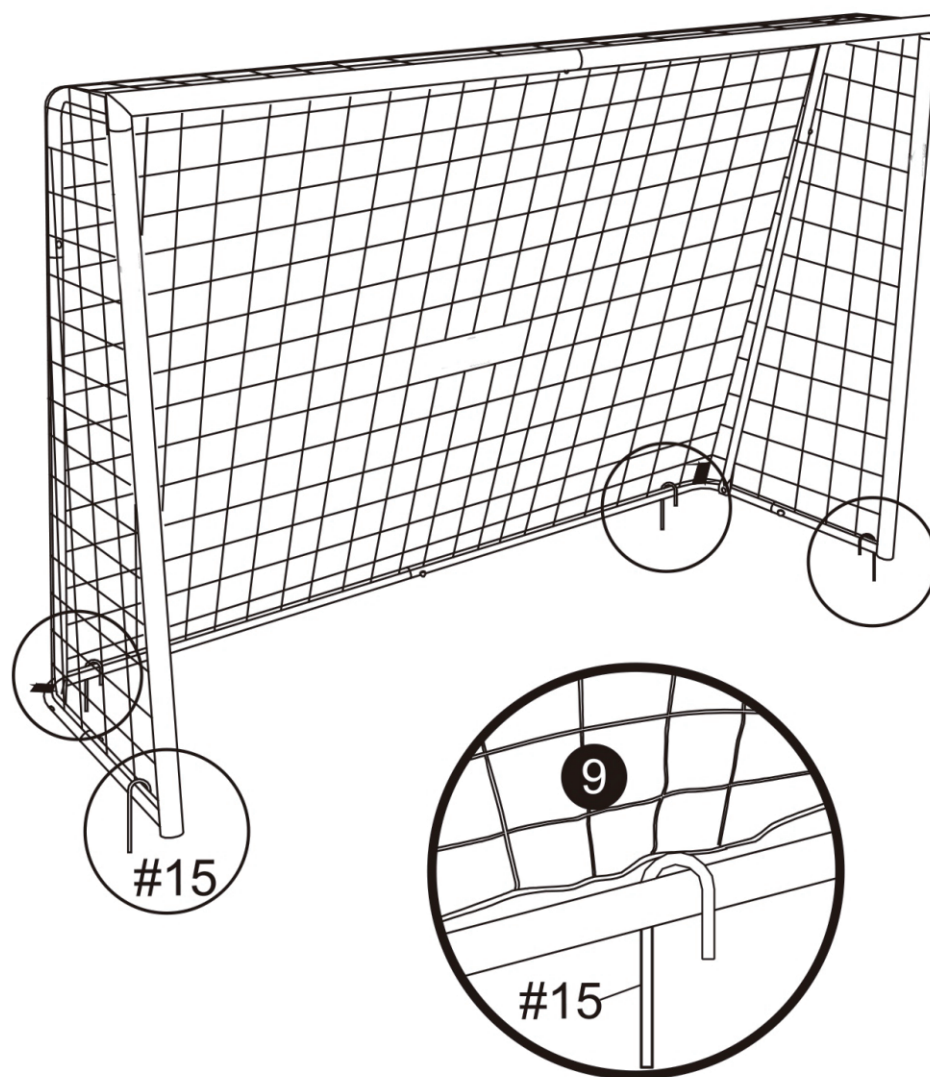

Advertencia:

- * Al ensamblar, se recomienda usar gafas de seguridad para proteger los ojos.
- * Los niños deben ser supervisados cuando jueguen con este equipo.
- * Utilice este producto solo en superficies planas y uniformes, no lo coloque en escaleras o pendientes.
- * Solo para uso en exteriores.
- * Mantenga el equipo al menos a 8 pies de distancia de objetos como cercas, garajes, casas, tendederos, ramas de árboles y cables eléctricos.
- * Use el sentido común al jugar con este producto.
- * Este producto es estable, se mantiene equilibrado durante el uso.
- * No se pare detrás de la red (o en la trayectoria del balón pateado) para evitar ser golpeado por el balón.
- * No se pare sobre este equipo, podría dañarlo y causar lesiones.
- * No utilice este producto como puenting o para ningún otro propósito que no esté descrito en este manual.



IN230600541V02_UK_FR_IT_ES

A62-022_A62-022V00



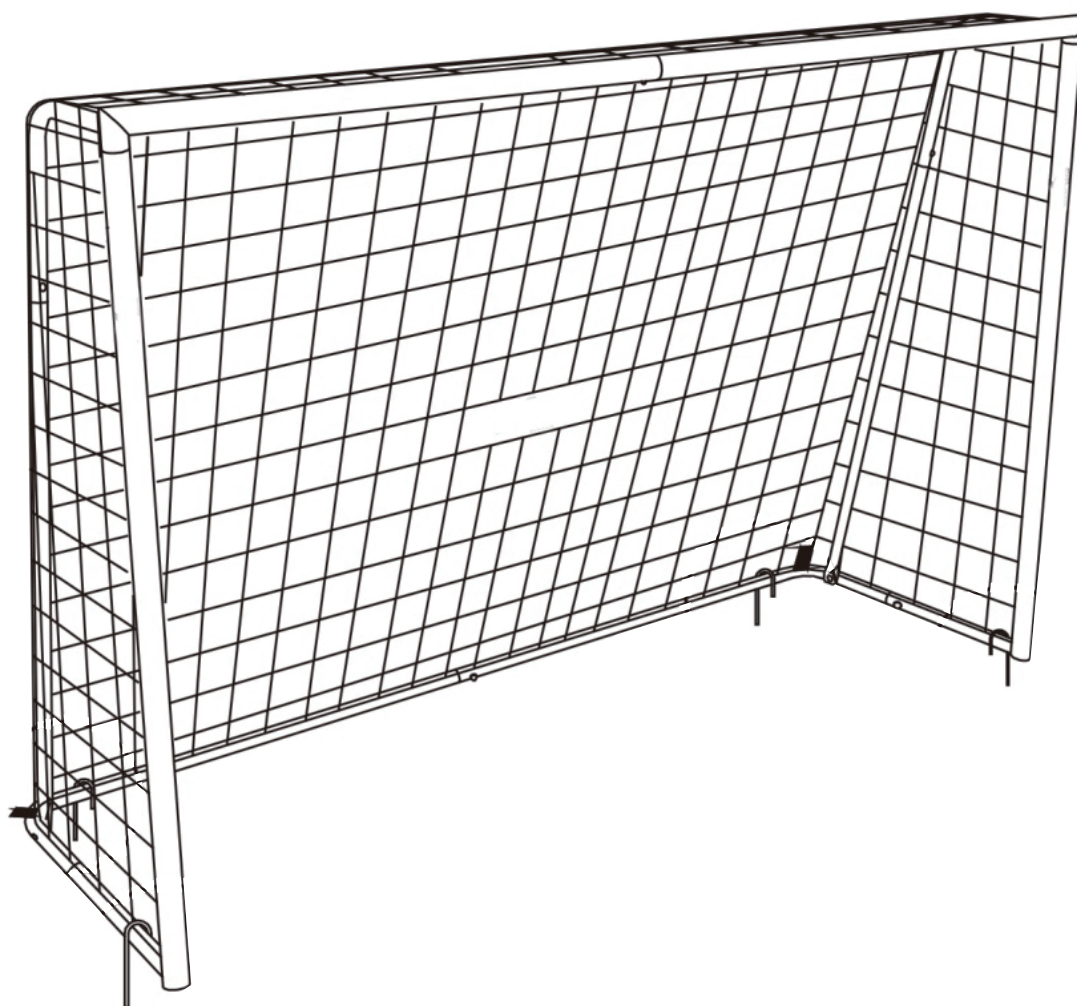















IT



IMPORTANTE - CONSERVARE QUESTE INFORMAZIONI
PER CONSULTARLE IN SEGUITO: LEGGERE ATTENTAMENTE

ISTRUZIONI DI ASSEMBLAGGIO

Parti, component e lista utensili

NO. PARTE	ILLUSTRAZIONE	QTA'
1		1
2		1
3		1
4		1
5		1
6		1
7		2
8		2
9		1
10		18
11		2
12		2
13		2
14		2
15		4
16		2
17		1
18		1

Istruzioni di montaggio

Step 1

Collegare la barra superiore #1 e la barra superiore #2.

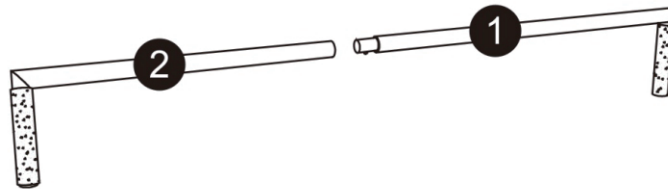

Step 2

Collega il palo destro #3 alla barra superiore #1 e il palo sinistro #4 alla barra superiore #2.

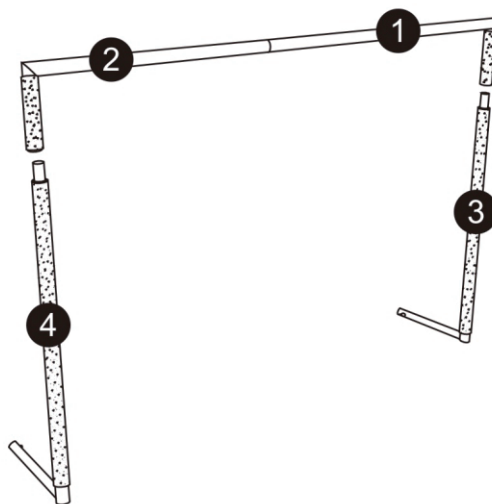

Step 3

Collegare i tubi base #5 e #6; quindi inserirli nei pali #3 e #4.

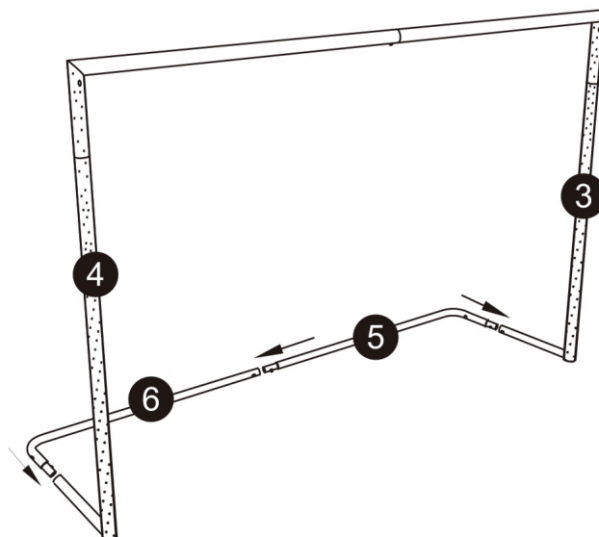

Istruzioni di montaggio

Step 4

Collegare il tubo curvo #7 e il tubo di supporto posteriore #8. Collegare l'estremità superiore alla barra superiore #1 usando il bullone #13 e la chiave a brugola #18. Collegare l'estremità inferiore al tubo base destro #5 utilizzando il bullone #12, la rondella #16, il dado #14, la chiave a brugola #18 e la chiave inglese #17 come mostrato nella figura ingrandita. Ripetere allo stesso modo sull'altro lato.

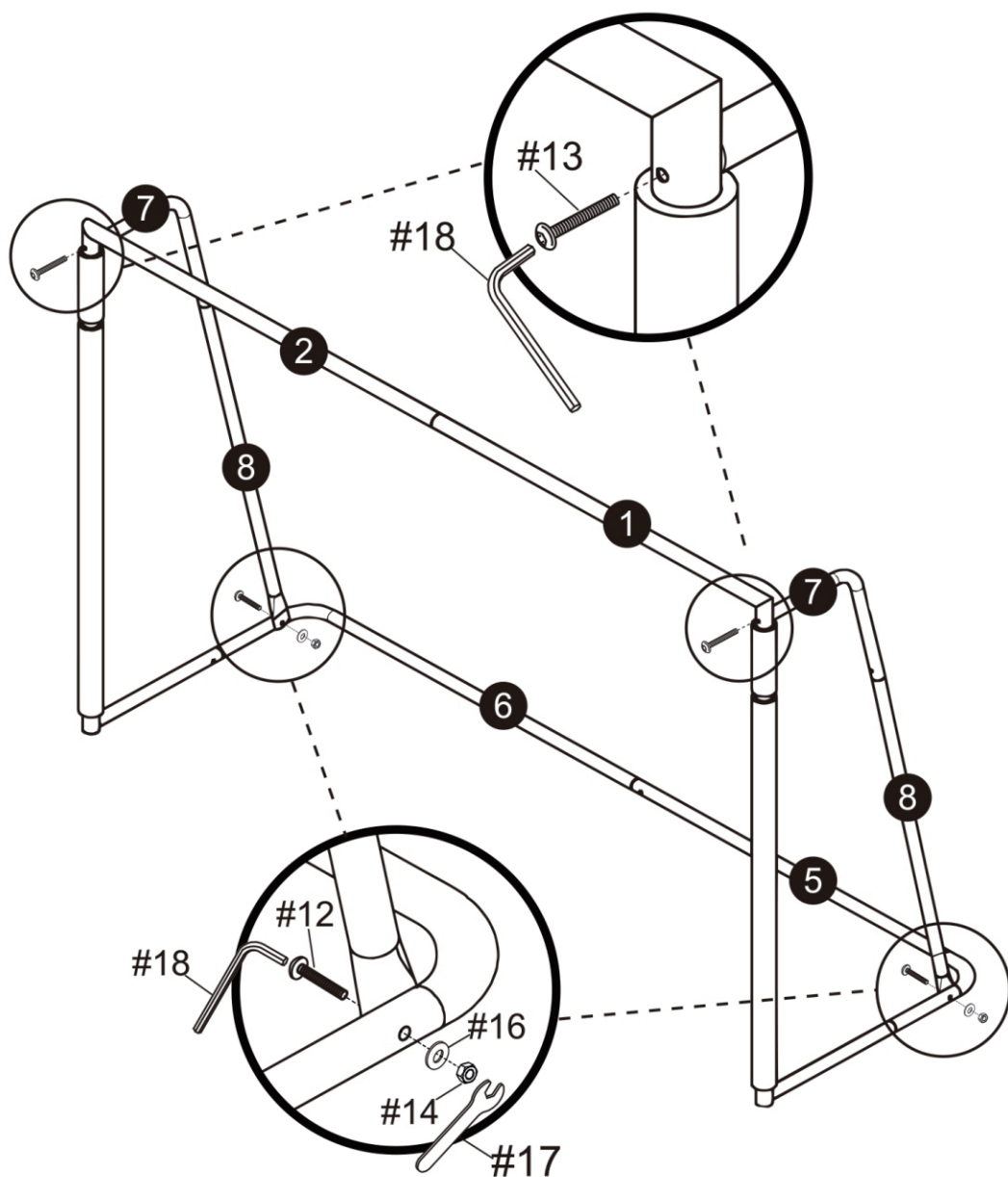

Istruzioni di montaggio

Step 5

Infilare la Rete #9 sopra la porta da calcio. Le linguette rosse sulla rete dovrebbero essere posizionate negli angoli inferiori della porta.

Fissare la rete alla porta su tutti i lati usando le cinghie #10 fornite. Per i montanti sinistro e destro #3 e #4, applicare la protezione #11. Distribuire uniformemente le 18 cinghie "Hook and Loop" su tutto il telaio della porta, sul palo sinistro #3 e sul palo destro #4.

Nota: il logo deve essere rivolto verso la parte aperta della porta.

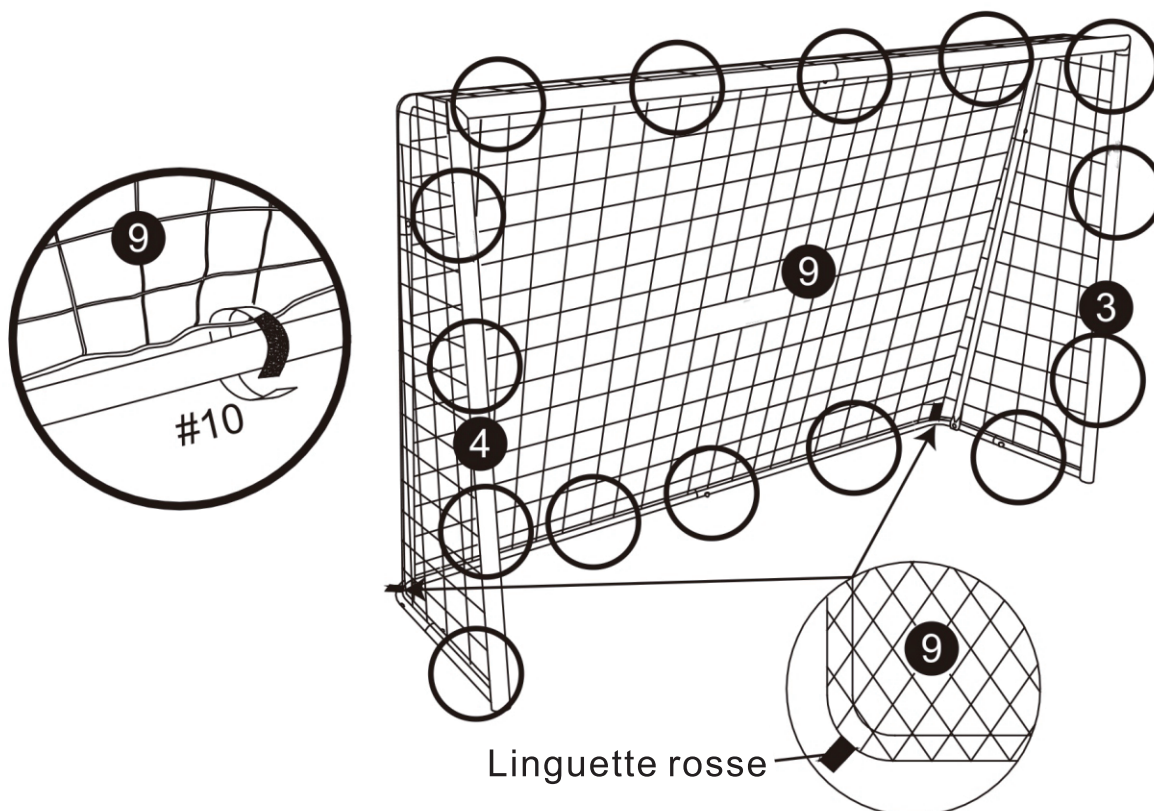

Istruzioni di montaggio

Step 6

Inserisci i paletti "J" #15 nel terreno nei quattro angoli.

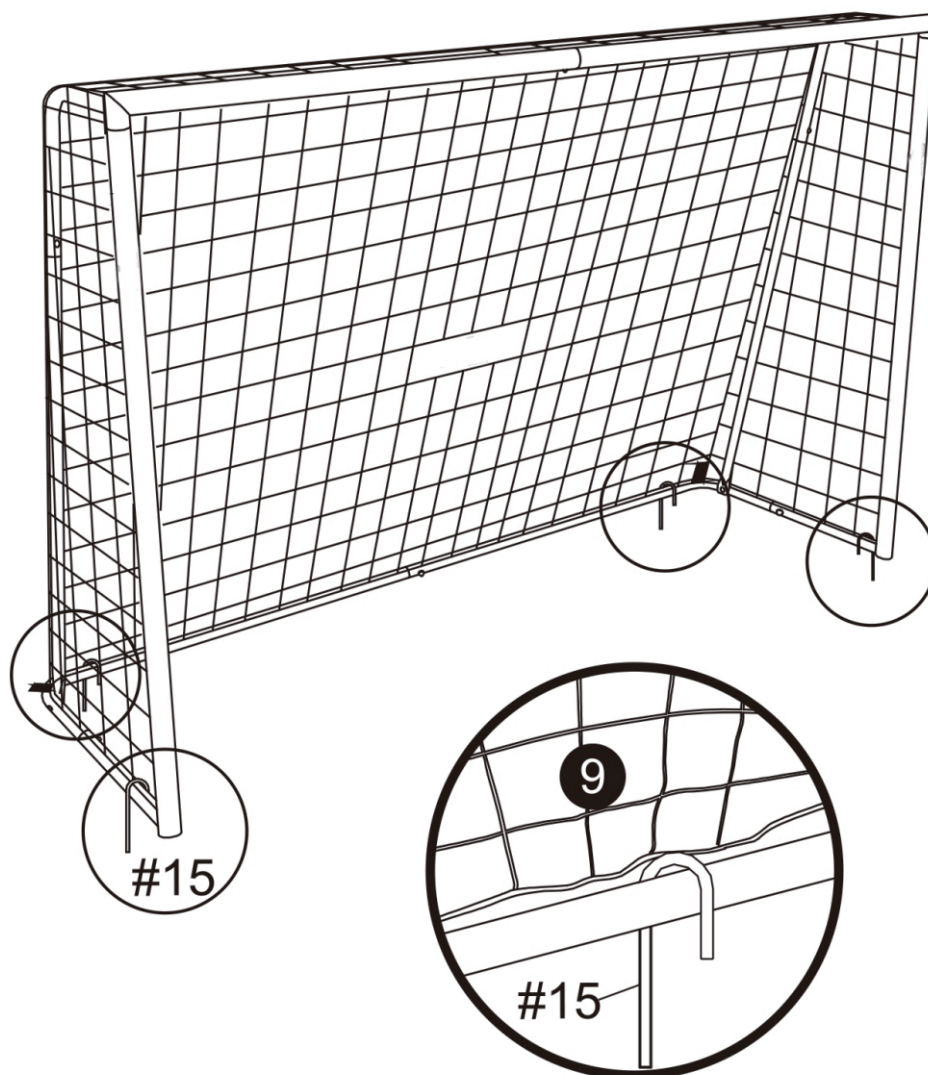

Avvertenze:

- * Durante l'assemblaggio, si raccomanda di indossare occhiali di sicurezza per proteggere gli occhi.
- * I bambini devono essere sorvegliati quando giocano con questo apparecchio.
- * Usare questo prodotto solo su superfici piane e uniformi - non posizionare su scale o pendii.
- * Solo per uso esterno.
- * Tenere l'attrezzatura ad almeno 8 piedi di distanza da oggetti come recinzioni, garage, case, fili del bucato, rami sporgenti e fili elettrici.
- * È necessario usare il buon senso quando si gioca con questo prodotto.
- * Questo prodotto è stabile e rimane in equilibrio durante l'uso.
- * Non posizionarsi dietro la rete (o sulla traiettoria del pallone calciato) per evitare di essere colpiti dal pallone.
- * Non stare in piedi sull'attrezzatura: potrebbe danneggiarla e causare lesioni.
- * Non utilizzare il prodotto come bungee o per altri scopi diversi da quelli descritti nel presente manuale.

UK

If you have any questions, please contact our customer care center.

Our contact details are below:



0044-800-240-4004



enquiries@mhstar.co.uk

IMPORTER ADDRESS:

MH STAR UK LTD

Unit 27, Perivale Park,

Horsenden lane South

Perivale, UB6 7RH

MADE IN CHINA

ES

Si tiene alguna pregunta, comuníquese con nuestro Centro de Atención al Cliente. Nuestros datos de contacto son los siguientes:



0034-931294512



atencioncliente@aosom.es

IMPORTADOR:

SPANISH AOSOM, S.L.

C/ ROC GROS, N° 15. 08550, ELS HOSTALETS DE

BALENYÀ, SPAIN.

B66295775

WWW.AOSOM.ES

ATENCIONCLIENTE@AOSOM.ES

TEL: 931294512

HECHO EN CHINA

FR

Si vous avez la moindre question, veuillez contacter notre centre d'assistance à la clientèle.

Nos coordonnées sont les suivantes:



0033-1-84166106



aosom@mhfrance.fr

Importé par:

MH France

2, rue Maurice Hartmann

92130 Issy-les-Moulineaux

France

Fabriqué en Chine

PT

Se tiver alguma dúvida, por favor contacte o nosso Centro de Atendimento ao Cliente. Os nossos dados de contacto são os seguintes:



0034-931294512



info@aosom.pt.

IMPORTADOR:

SPANISH AOSOM, S.L

C.ROC GROS N.15, 08550. ELS HOSTALETS DE BALENYÀ

TEL: 931294512 (SEG-SEX DAS 7:30H ÀS 16:30H)

INFO@AOSOM.PT

WWW.AOSOM.PT

DE

Wenn Sie Fragen haben, wenden Sie sich bitte an unser Kundendienstzentrum.

Unsere Kontaktdaten stehen unten:



0049-(0)40-88307530



service@aosom.de

ADRESSE DES IMPORTEUR:

MH Handel GmbH

Wendenstraße 309

D-20537 Hamburg

Germany

IN CHINA HERGESTELLT

IT

In caso di dubbio, si prega di contattare il nostro centro assistenza clienti. I nostri dettagli di contatto sono di seguito:



0039-0249471447



clienti@aosom.it

IMPORTATO DA:

AOSOM Italy srl

Centro Direzionale Milanofiori

Strada 1 Palazzo F1

20057 Assago (MI)

P.I.: 08567220960

FATTO IN CINA

