

**3 in 1**



## **CHILDREN'S Pedal Engineering Vehicle**



\* **WARNING:** Certification Age: 18+ months; Max weight: 25 kg.

**IMPORTANT, RETAIN FOR FUTURE REFERENCE: READ CAREFULLY**

# ASSEMBLY INSTRUCTION

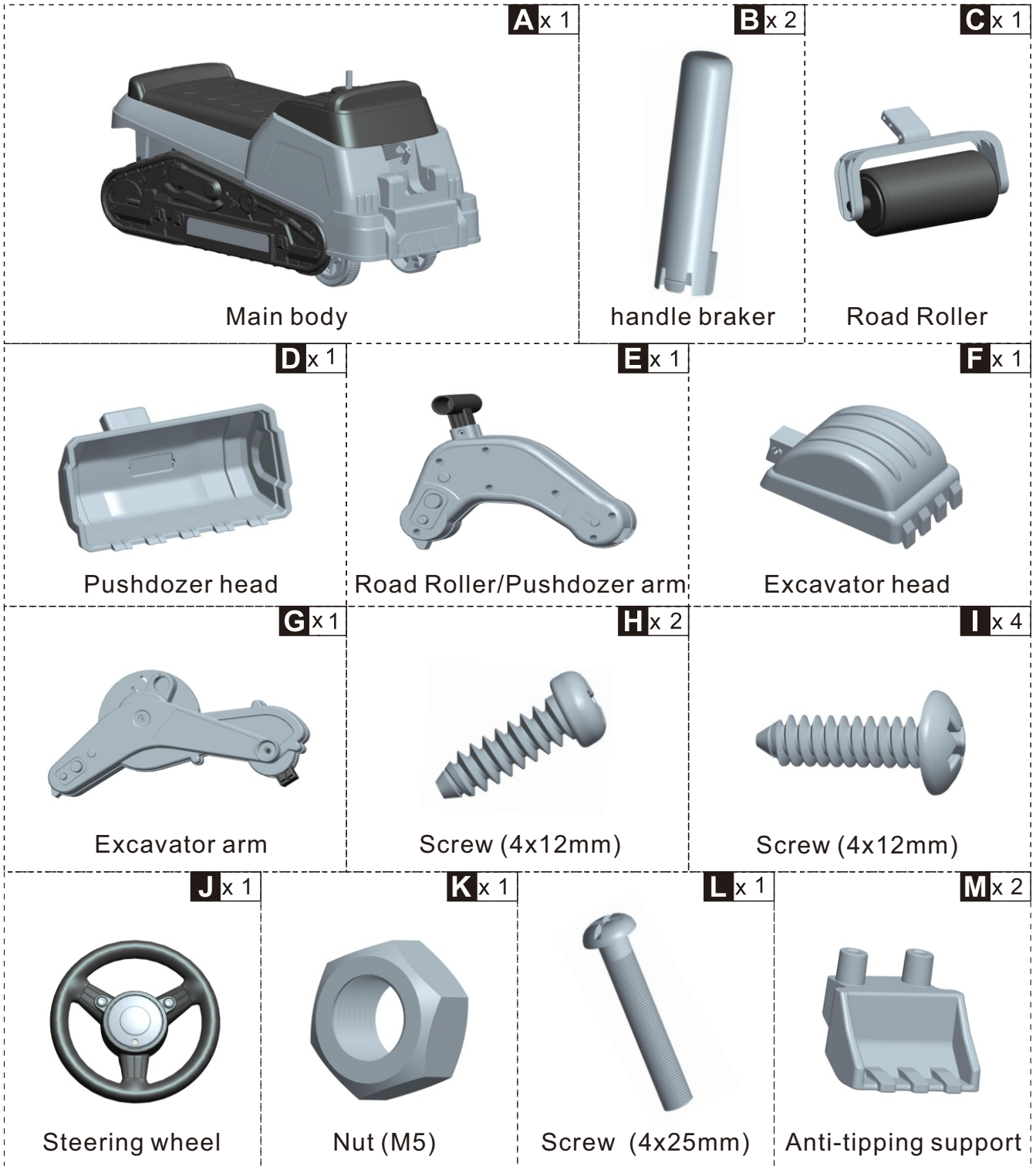
**Note:**

Some parts are under the seat, please take out them under seat before assembly.

Assembly tools required:



Screwdriver (not included)

**⚠ WARNING:**

1. CHOKING HAZARD—Small parts.
2. Only allowed for adults to install, keep children away.
3. To be used under the direct supervision of an adult.
4. Just only allow one child to use.
5. Please use on a flat and clean surface. Never use near steps, sloped driveways, hills roadways, alleys, swimming pool areas, road, on grass or wet surfaces or other bodies of water.
6. Before driving toy car each time, adult should inspect screws of every parts, please tighten the screw cap if any looseness. secure all fasteners before every ride.
7. Always wear shoes and suitable protective equipment. always wear a local standard approved helmet while riding, with the chinstrap securely fastened.
8. Do not ride the product at dusk, at night or at times of limited visibility.
9. Always comply with local laws and regulations.

**MAINTENANCE & CARE**

- A. Keep all instructions and parts relating to this product for future reference.
- B. Regularly check for damage and that all screws are securely tightened.
- C. Check that the seat is securely fastened.
- D. Lubricate the chain as often as required.

## Assembly Instruction

**NOTE:** Some parts under the seat, please take out them under seat before assembly.

### Pushdozer head assembly

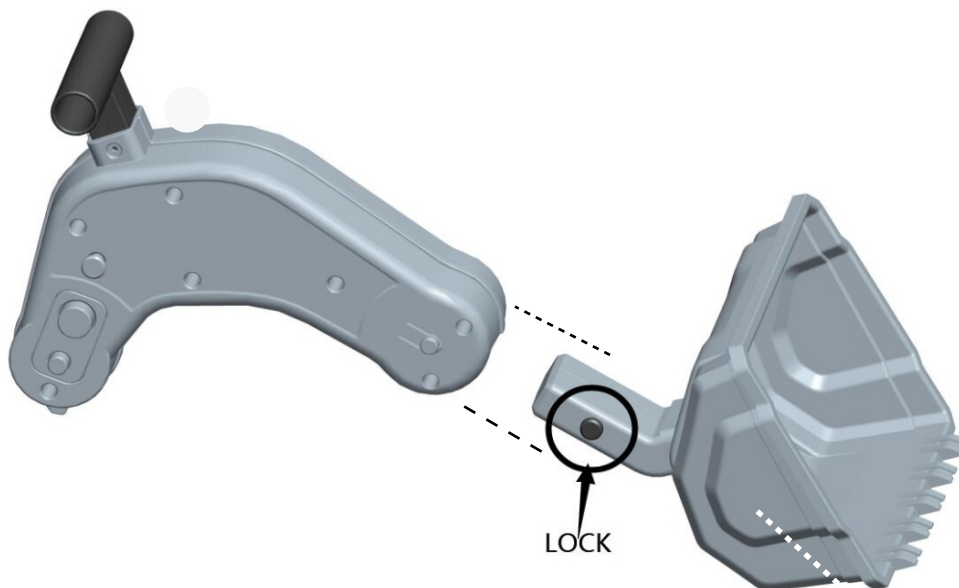

Press the lock on the pushdozer head and insert it to the pushdozer arm as picture shown.

**NOTE:** The road roller and pushdozer head share with one arm, if use the pushdozer head, need to disassembly the road roller.

# Assembly Instruction

## Road roller assembly

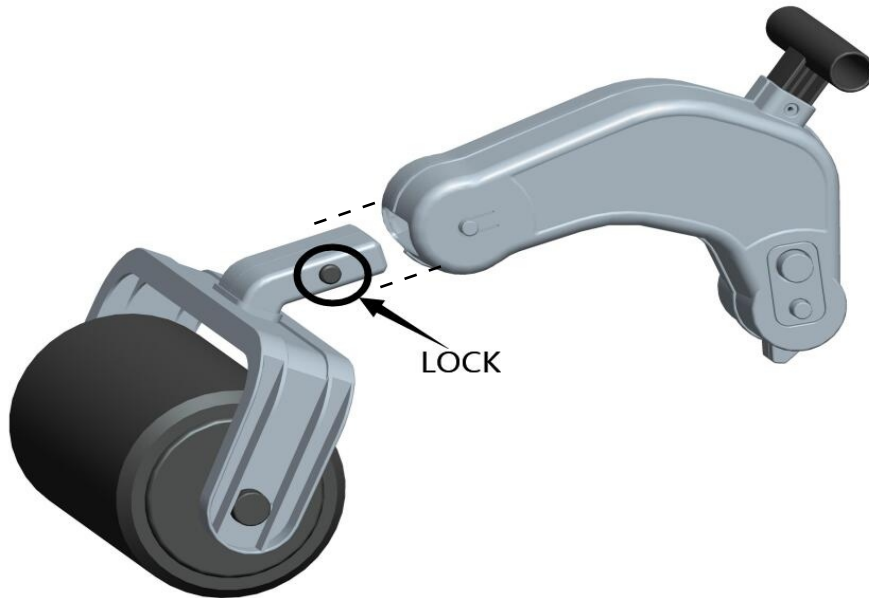

Press the lock on the road roller and insert it to the road roller arm as picture shown.

**NOTE:** The road roller and pushdozer head share with one arm, if use the road roller, need to disassembly the pushdozer head.

## Excavator arm hand bar assembly

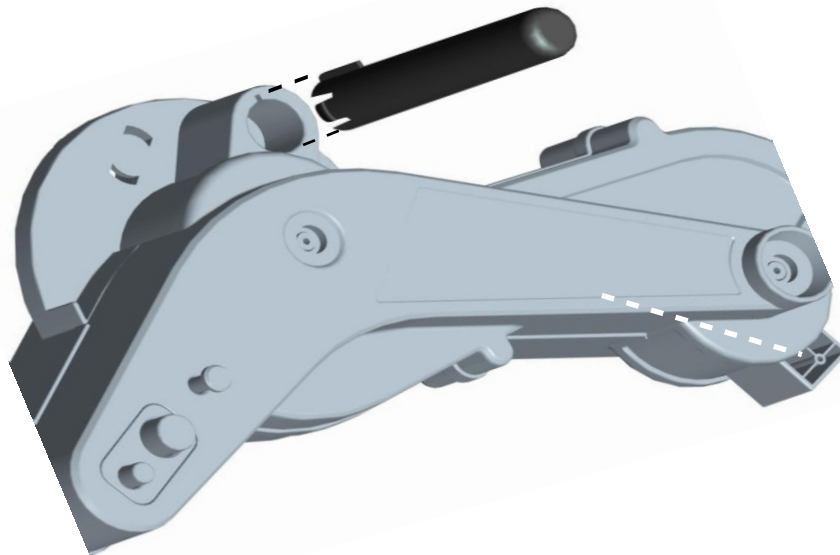

Please insert the left and right hand bar to excavator arm as picture shown.

# Assembly Instruction

## Excavator assembly

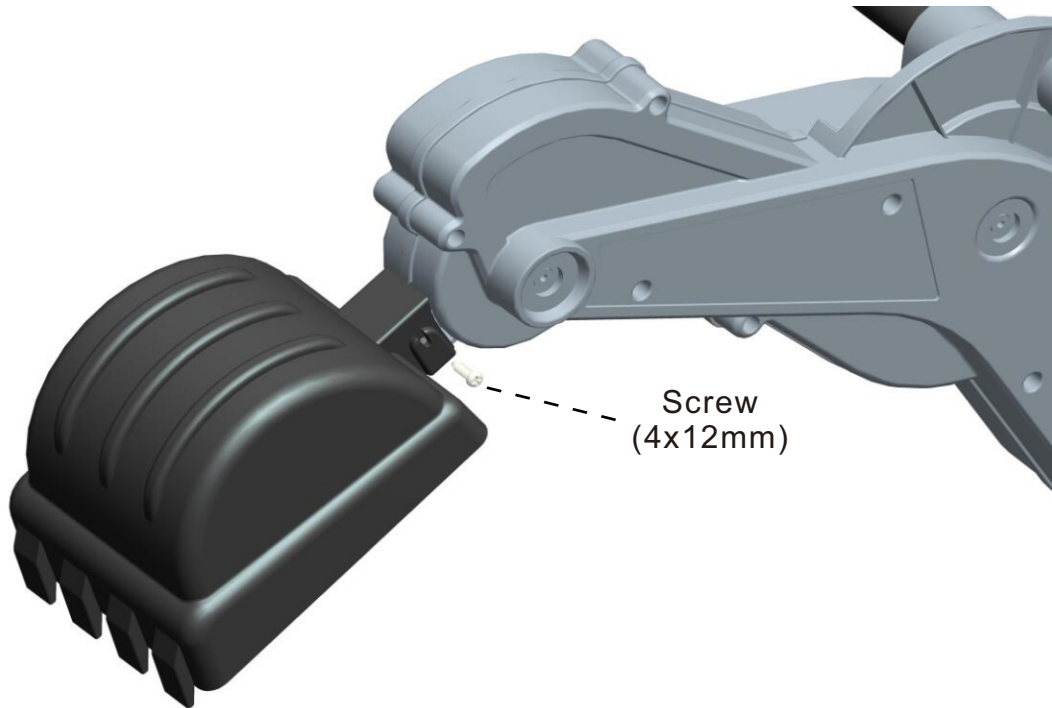

Assembly the excavator head and fasten with 2 screws for two sides as picture shown.

## Front Anti-tipping support assembly

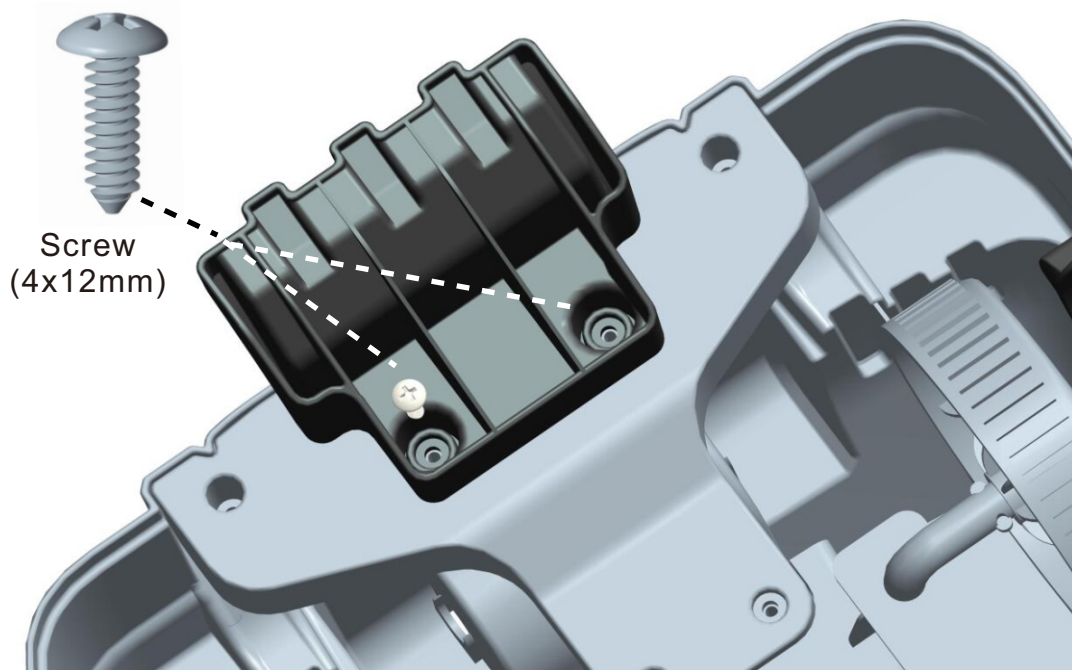

Insert the anti-tipping support and fasten with 2 screws as picture shown.

# Assembly Instruction

## Rear Anti-tipping support assembly

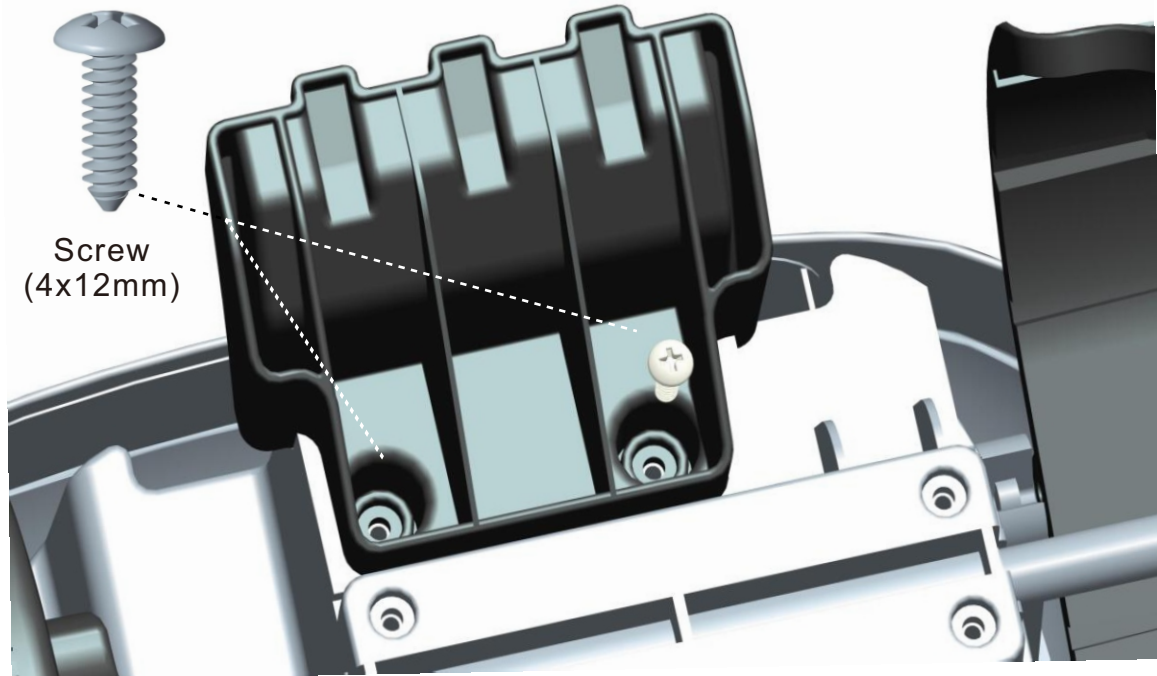

Insert the anti-tipping support and fasten with 2 screws as picture shown.

## Steering wheel assembly

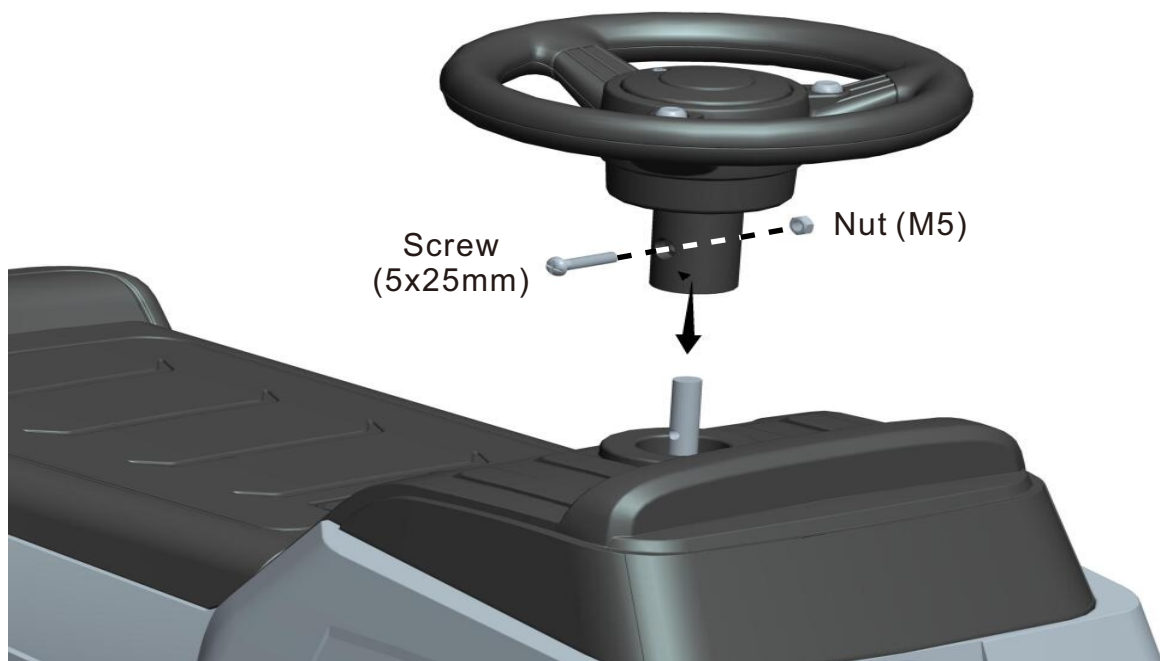

Place the steering wheel into the steering column. Tighten the screw with nut.

# Assembly Instruction

## Assembly Pushdozer head/Excavator head/Road roller

**NOTE:** The road roller, pushdozer head and excavator share with one main body. One time can only use one of them as you like.

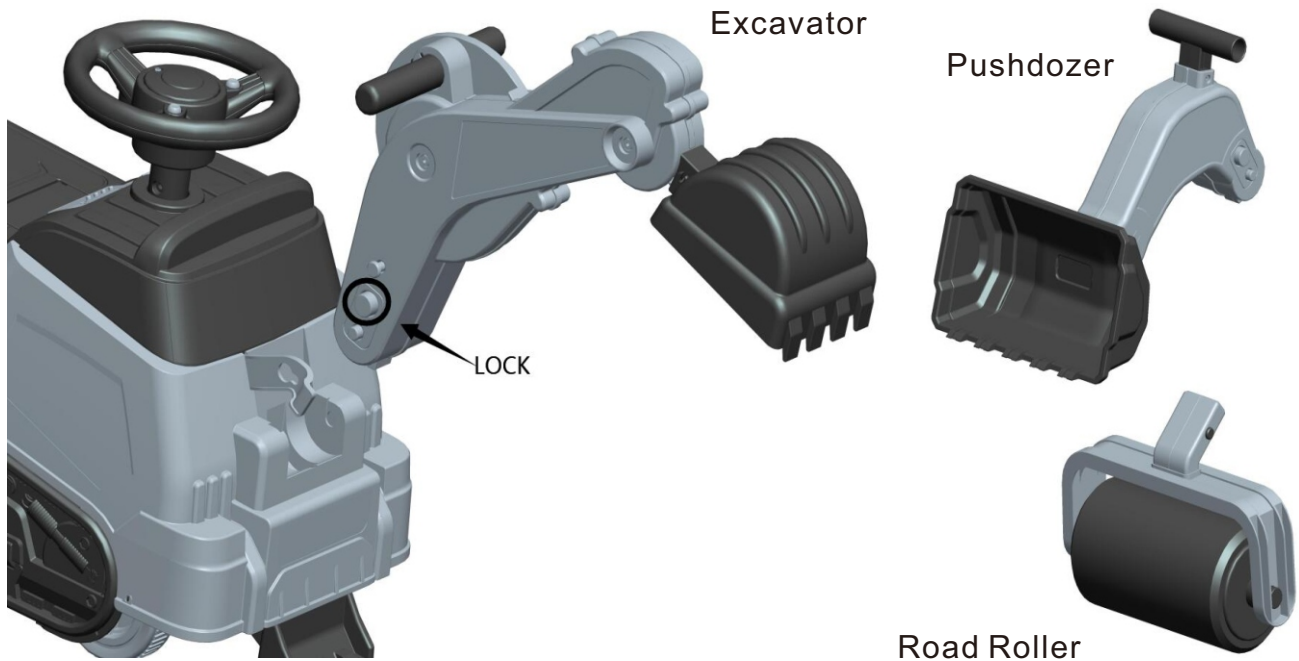

Press the lock on the pushdozer arm and place it to the main body as picture shown. If use the road roller or excavator, need to disassembly the pushdozer head. Use the same method to assembly the road roller or excavator.

## Battery Installation

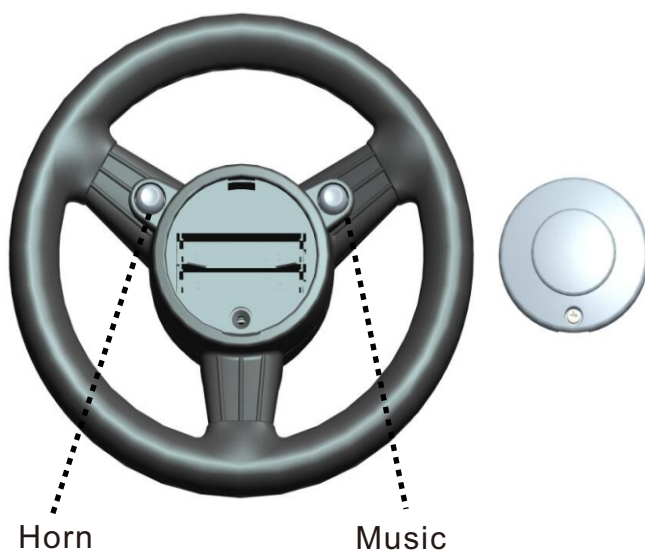

1. For longer life, use alkaline batteries.
2. Loosen the screw into the battery compartment door with a Phillips screwdriver and remove the door.
3. Insert two, new AAA (LR03) alkaline batteries.
4. Replace the battery compartment door and tighten the screw. Do not over-tighten.

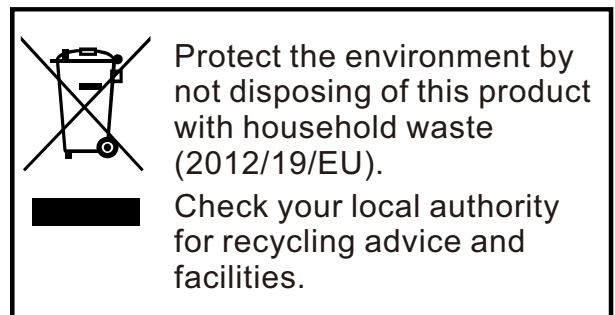

# Parts Diagram

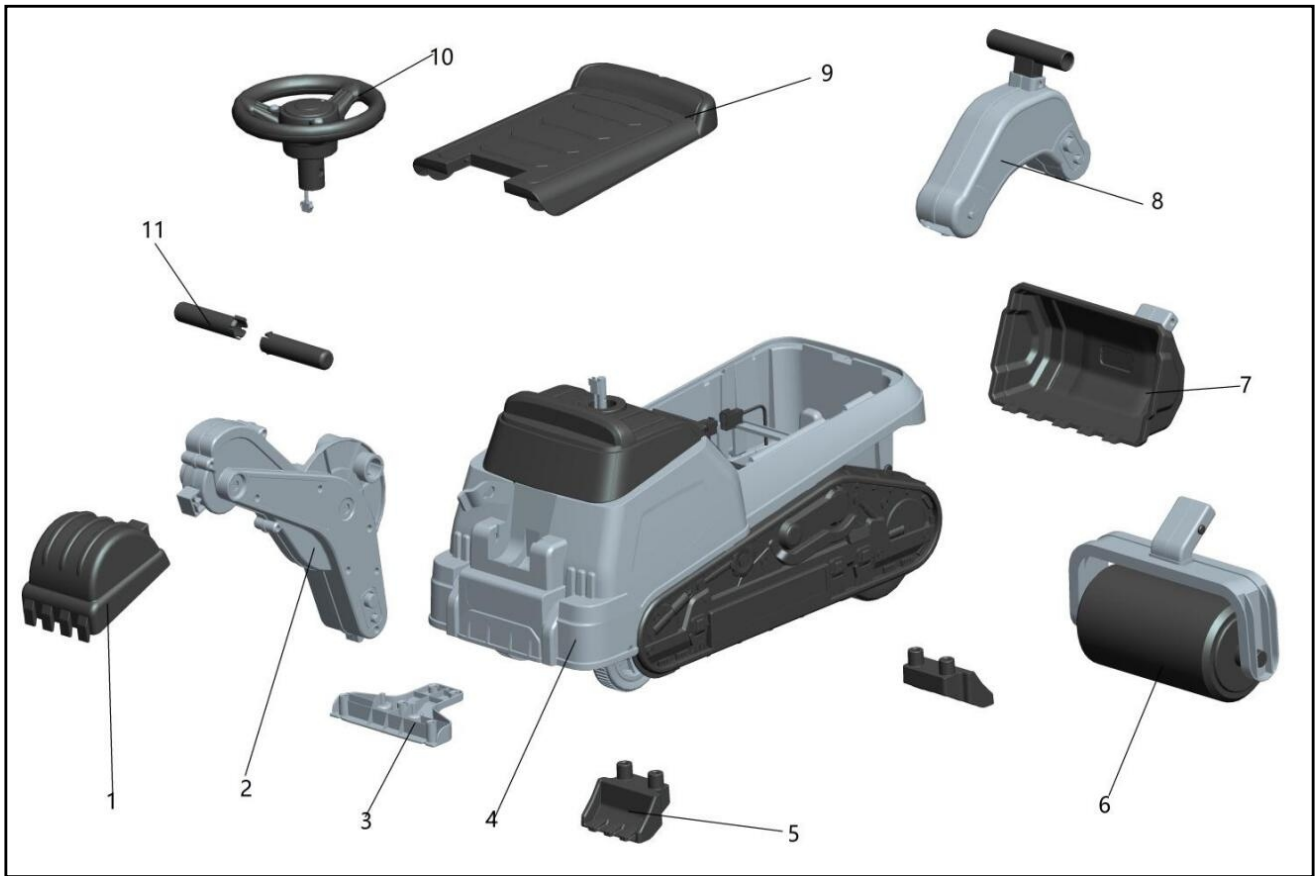

No. Part	Quantity	No. Part	Quantity
1.Excavator head	1	7.Pushdozer head	1
2.Excavator arm	1	8.Pushdozer/Road roller arm	1
3.Front support	1	9.Seat	1
4.Main body	1	10.Steering wheel	1
5.Anti-tipping support	2	11.Hand bar	2
6.Road roller	1		



**3 in 1****VÉHICULE À PÉDALES POUR ENFANTS**

\* ATTENTION: Âge de certification: 18+ mois; Poids maximum: 25 kg.

**IMPORTANT : A LIRE ATTENTIVEMEN ET A CONSERVER POUR VOUS  
Y REFERER ULTERIEUREMENT**

**ASSEMBLAGE D'INSTRUCTIONS**

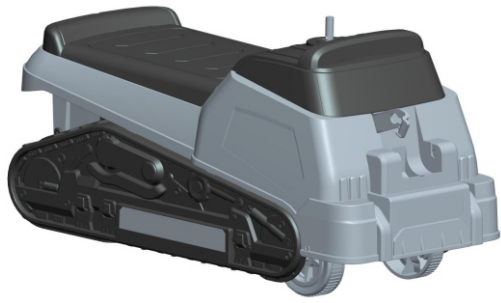

Corps principal

A x 1



Barre de guidage

B x 2



Rouleau compacteur

C x 1

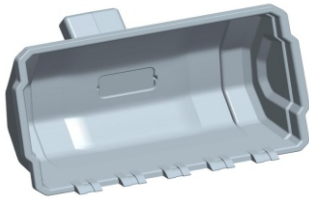

Tête de bulldozer

D x 1



Bras du Rouleau compacteur / bulldozer

E x 1

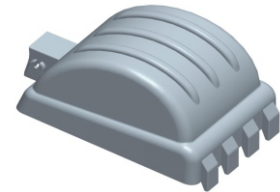

Tête d'excavatrice

F x 1

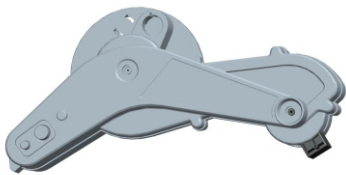

Bras d'excavatrice

G x 1

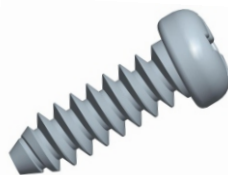

Vis (4x12mm)

H x 2

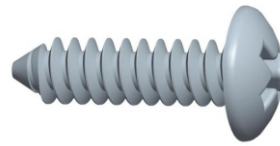

Vis (4x12mm)

I x 4



Volant

J x 1

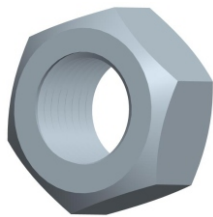

Écrou (M5)

K x 1

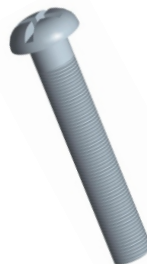

Vis (4x25mm)

L x 1

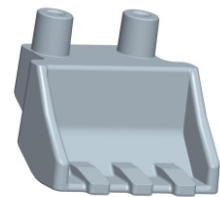

Support anti-basculement

M x 2

**REMARQUE:**

Certaines pièces se trouvent sous le siège, veuillez les retirer avant l'assemblage.

Outils d'assemblage requis:



Tournevis (non inclus)

## **⚠ AVERTISSEMENT :**

1. DANGER D'ÉTOUFFEMENT - Petites pièces.
2. Installation par des adultes uniquement, tenir les enfants à l'écart.
3. À utiliser sous la surveillance directe d'un adulte.
4. Ne doit être utilisé que par un seul enfant à la fois.
5. À utiliser sur une surface plane et propre. Ne jamais utiliser à proximité d'un escalier, d'une entrée en pente, d'une route en pente, d'une allée, d'une piscine, d'une route, sur l'herbe ou sur des surfaces mouillées ou d'autres plans d'eau.
6. Avant de conduire à chaque fois le jouet, l'adulte doit inspecter les vis de chaque pièce, veuillez serrer le bouchon à vis s'il est desserré. Fixez toutes les attaches avant chaque trajet.
7. Portez toujours des chaussures et un équipement de protection approprié. Portez toujours un casque homologué selon les normes locales pendant que vous roulez, avec la jugulaire solidement attachée.
8. Ne pas rouler au crépuscule, la nuit ou à des heures de visibilité réduite.
9. Respectez toujours les lois et règlements locaux.

## **ENTRETIEN ET MAINTENANCE**

- A. Conservez toutes les instructions et les pièces relatives à ce produit pour pouvoir vous y référer ultérieurement.
- B. Vérifiez régulièrement que le produit n'est pas endommagé et que toutes les vis sont bien serrées.
- C. Vérifier que le siège est bien fixé.
- D. Lubrifiez la chaîne aussi souvent que nécessaire.

# **INSTRUCTIONS D'ASSEMBLAGE**

**REMARQUE:** Certaines pièces se trouvent sous le siège, veuillez les retirer avant l'assemblage.

## **Assemblage de la Tête de bulldozer**

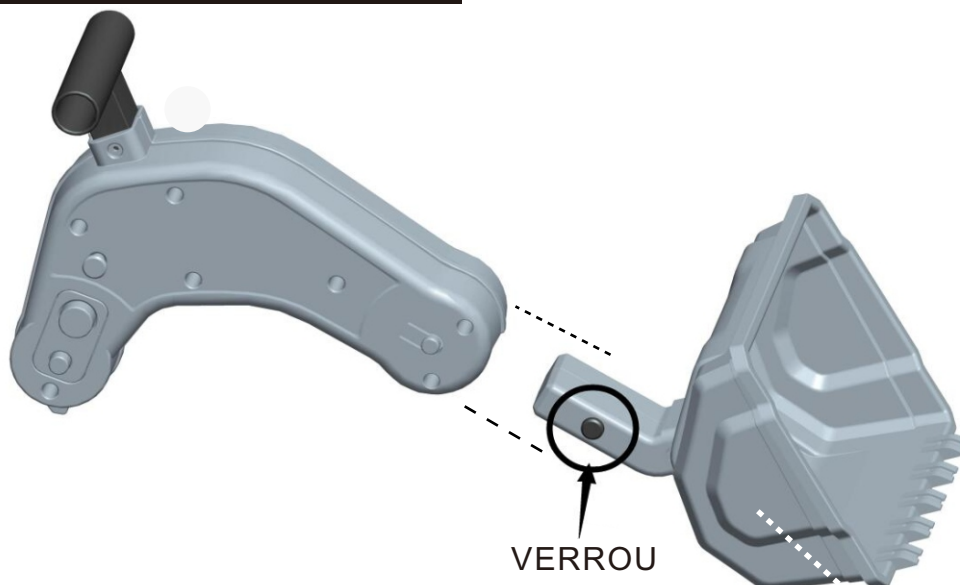

Appuyez sur le verrou de la tête de bulldozer et insérez-la dans le bras de bulldozer comme indiqué sur l'image.

**REMARQUE :** Le Rouleau compacteur et la tête de bulldozer partagent le même bras, si vous utilisez la tête de bulldozer, vous devez démonter le Rouleau compacteur.

# INSTRUCTIONS D'ASSEMBLAGE

## Assemblage du Rouleau compacteur

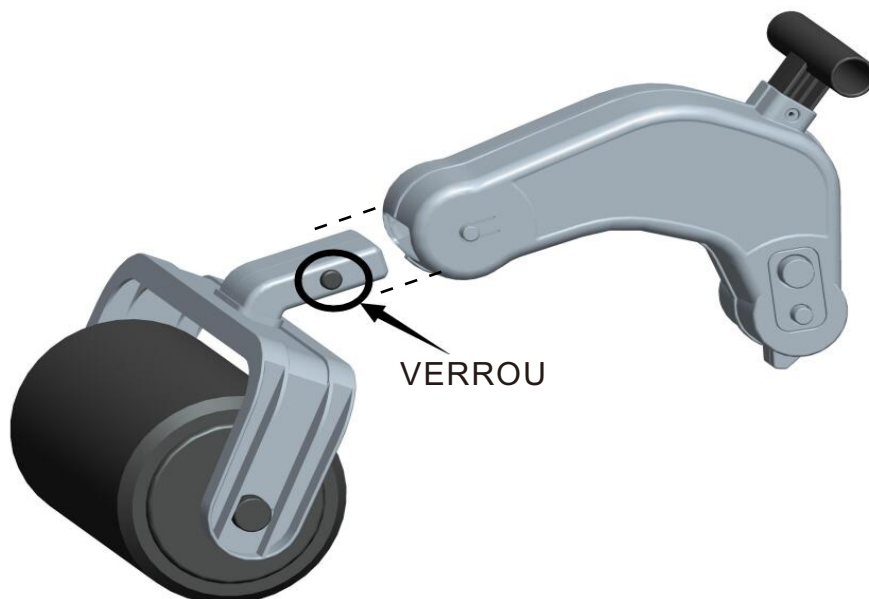

Appuyez sur le verrou du Rouleau compacteur et insérez-le dans le bras de Rouleau compacteur comme indiqué sur l'image.

**REMARQUE:** Le Rouleau compacteur et la tête de bulldozer partagent le même bras, si vous utilisez le Rouleau compacteur, vous devez démonter la tête de bulldozer.

## Assemblage de la barre de guidage et du bras d'excavatrice

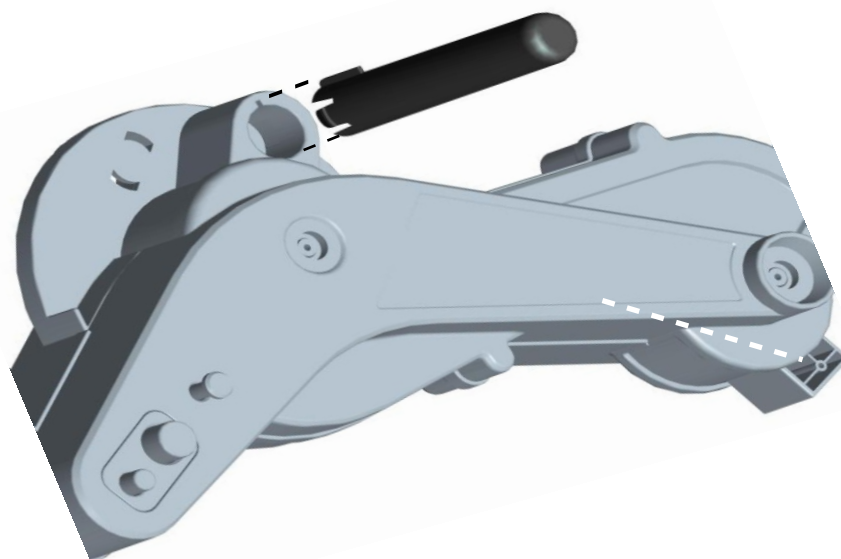

Insérez la barre de guidage gauche et droite dans le bras d'excavatrice comme indiqué sur l'image.

# INSTRUCTIONS D'ASSEMBLAGE

## Assemblage la tête d'excavatrice

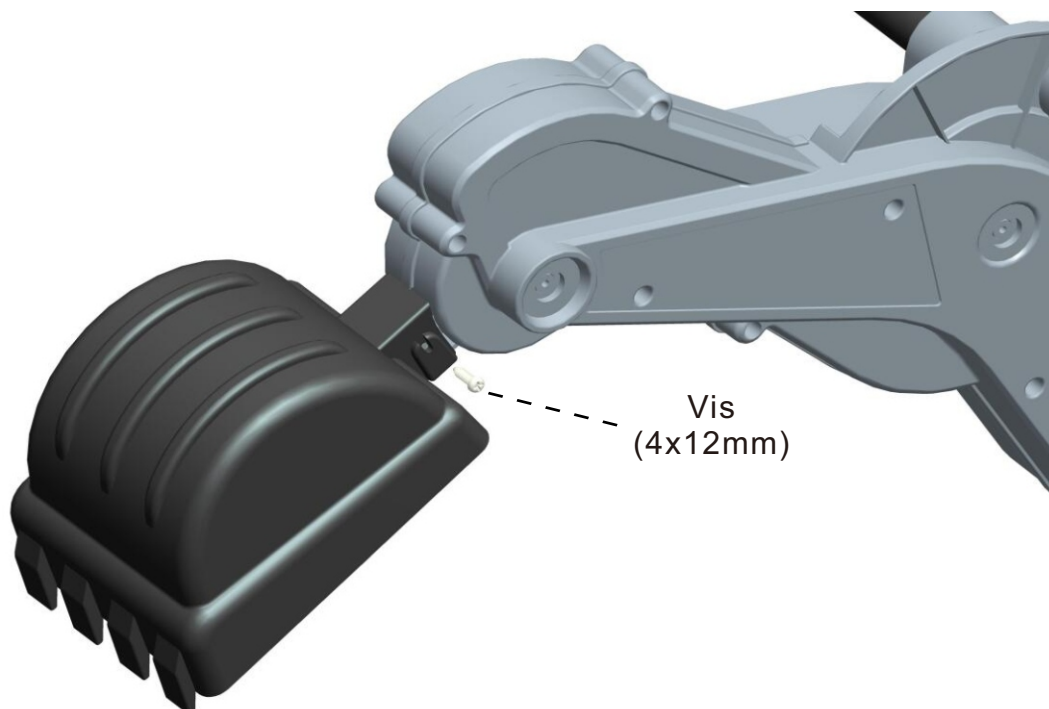

Assemblez la tête d'excavatrice et fixez-la avec 2 vis de chaque côté comme indiqué sur l'image.

## Assemblage du support anti-basculement avant

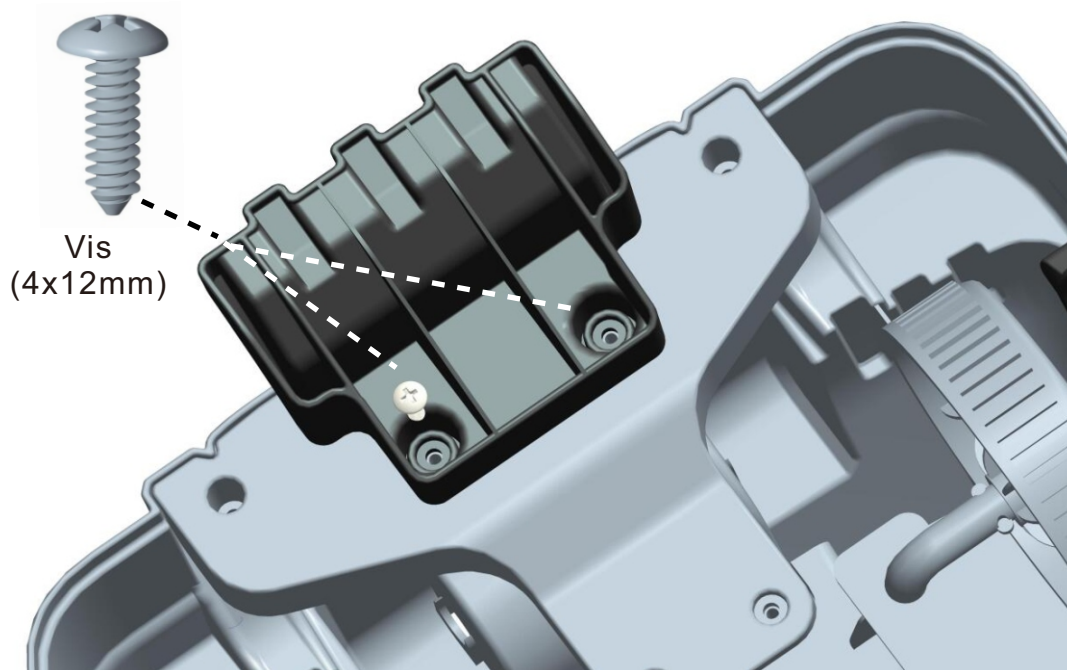

Insérez le support anti-basculement et fixez-le avec 2 vis comme indiqué sur l'image.

# INSTRUCTIONS D'ASSEMBLAGE

## Assemblage du support anti-basculement arrière

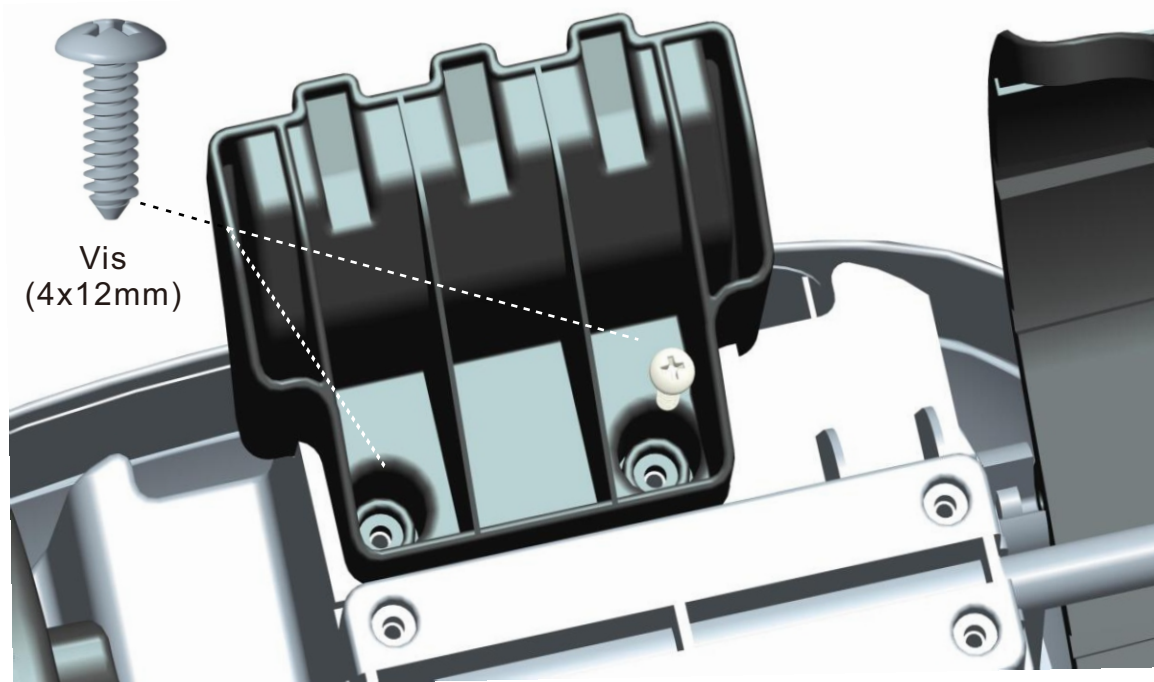

Insérez le support anti-basculement et fixez-le avec 2 vis comme indiqué sur l'image.

## Assemblage du volant

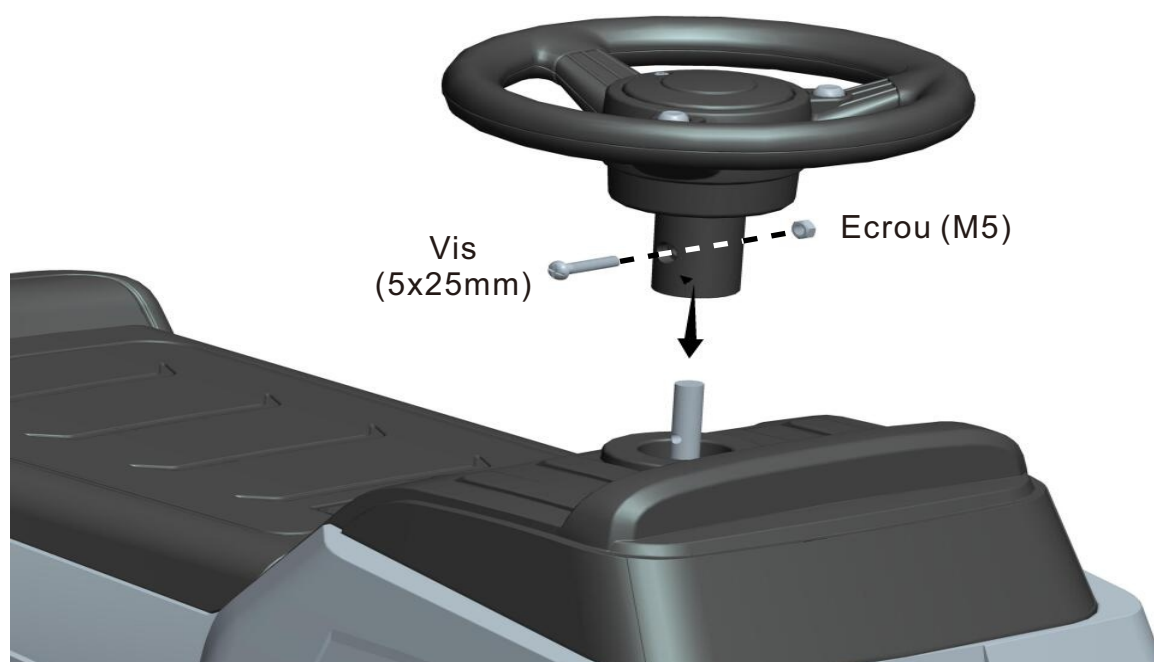

Placez le volant dans la colonne de direction. Serrez la vis avec l'écrou.

# INSTRUCTIONS D'ASSEMBLAGE

## Assemblage de la tête de bulldozer/tête d'excavatrice/Rouleau compacteur

**REMARQUE:** Le Rouleau compacteur, la tête de bulldozer et l'excavatrice partagent un corps principal. Vous ne pouvez utiliser qu'un seul d'entre eux à la fois, selon vos préférences.

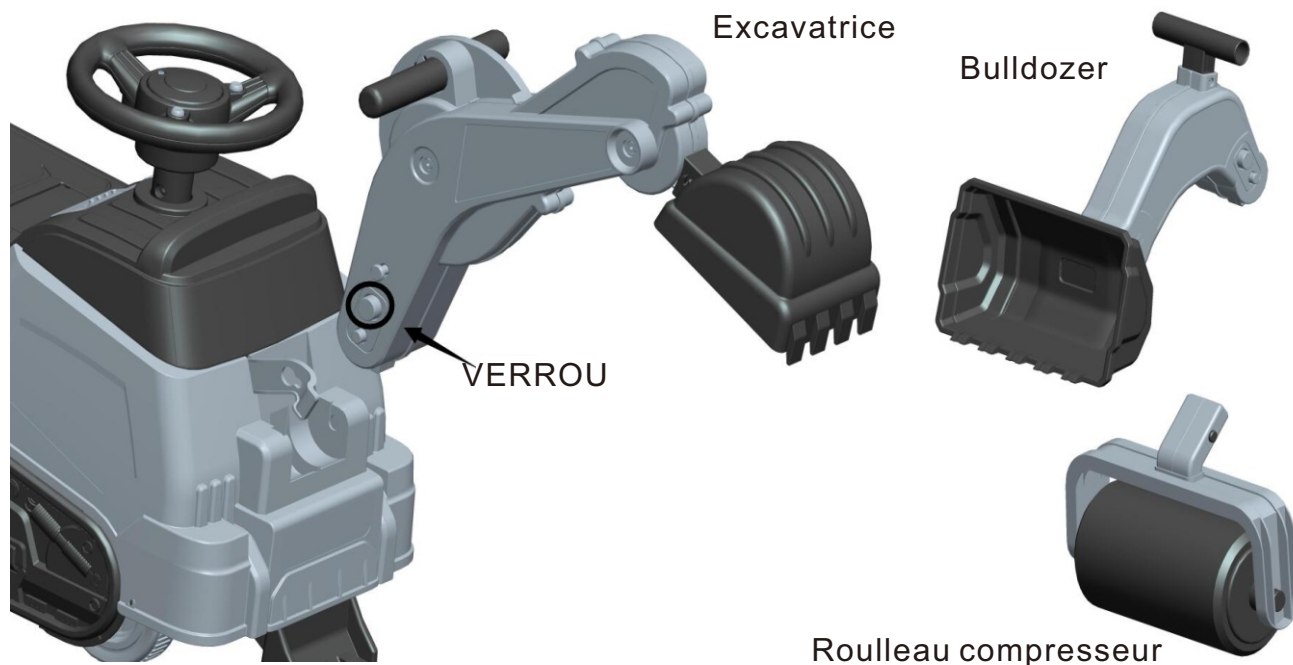

Appuyez sur le verrou du bras de bulldozer et placez-le sur le corps principal comme indiqué sur l'image. Si vous utilisez le Rouleau compacteur ou l'excavatrice, vous devez démonter la tête de bulldozer. Utilisez la même méthode pour assembler le Rouleau compacteur ou l'excavatrice.

## Installation des piles

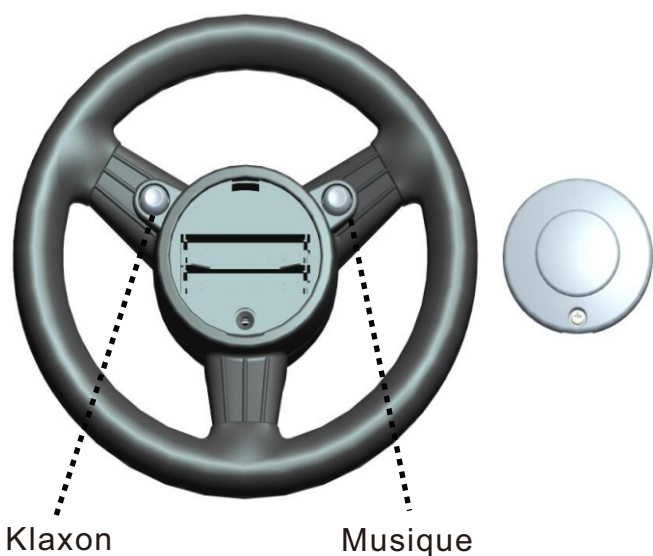

1. Pour prolonger la durée de vie de l'appareil, utilisez des piles alcalines.
2. Desserrez la vis de la porte du compartiment à piles à l'aide d'un tournevis cruciforme et retirez la porte.
3. Insérez deux piles alcalines AAA (LR03) neuves.
4. Remettez la porte du compartiment à piles en place et serrez la vis. Ne pas trop serrer.

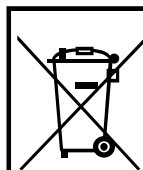

Veillez protéger l'environnement en ne jetant pas ce produit avec les ordures ménagères (2012/19/EU).

Renseignez-vous auprès des autorités locales pour obtenir des conseils et des possibilités de recyclage.

# Vue d'ensemble des pièces

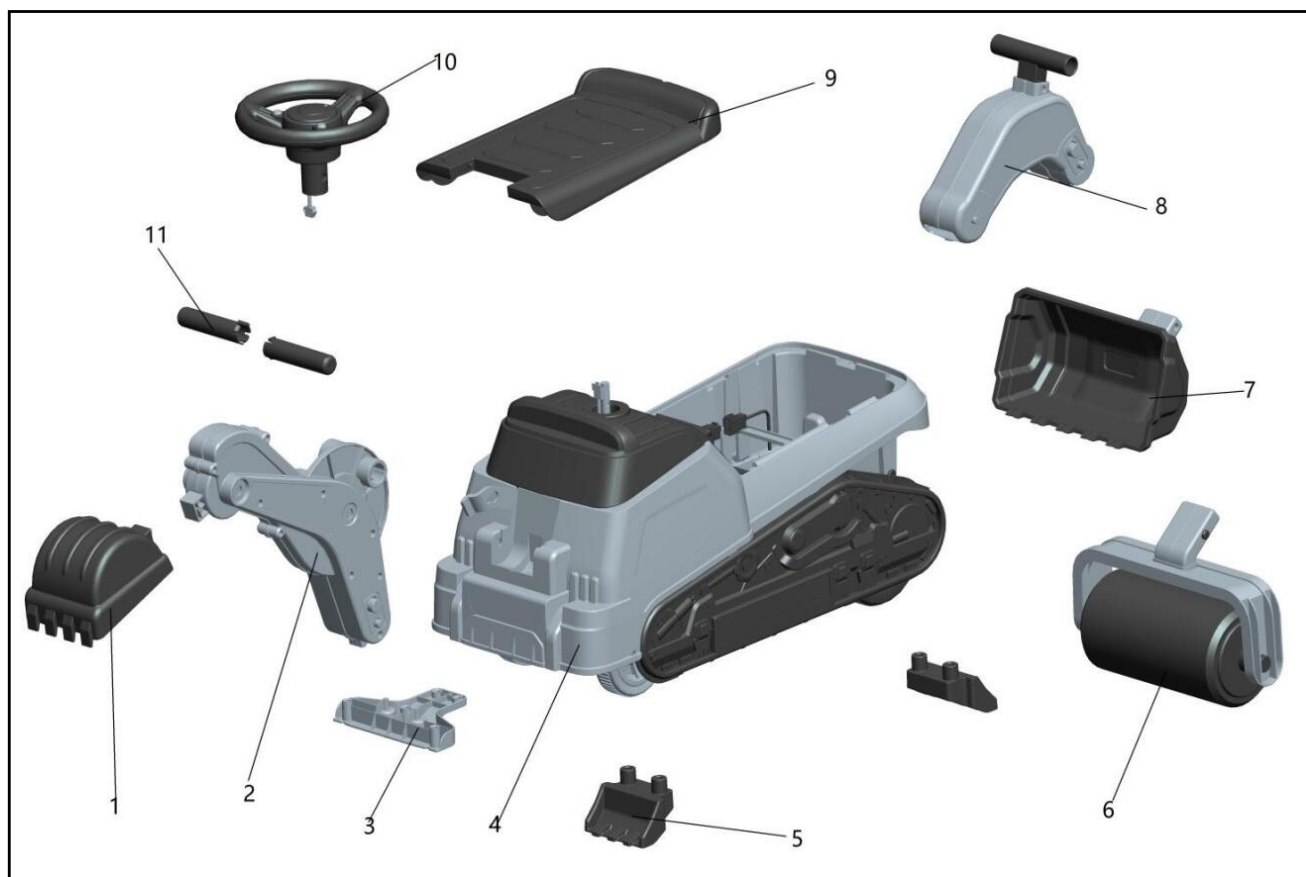

Numéro. Pièce	Quantité	Numéro. Pièce	Quantité
1. Tête d'excavatrice	1	7. Tête de bulldozer	1
2. Bras d'excavatrice	1	8. Bras de bulldozer/rouleau compacteur	1
3. Support avant	1	9. Siège	1
4. Corps principal	1	10. Volant	1
5. Support anti-basculement	2	11. Barre de guidage	2
6. Rouleau compacteur	1		



**3 in 1****KINDER-Tretfahrzeug**

\* **WARNUNG:** Zertifizierungsalter: 18+ Monate; Max. Gewicht: 25 kg.

**WICHTIG! SORGFÄLTIG LESEN UND FÜR SPÄTER NACHSCHLAGEN  
AUFBEWAHREN**

**MONTAGEANWEISUNGEN**

A x 1

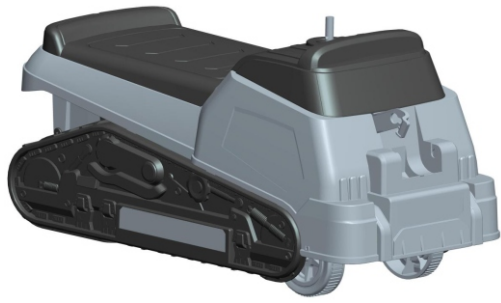

Hauptkörper

B x 2



Schiebebügel

C x 1



Straßenwalze

D x 1

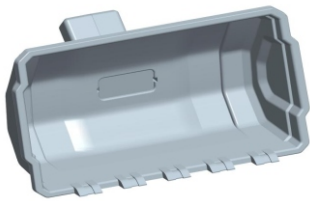

Planierraupen-Kopf

E x 1

Straßenwalze /  
Planierraupe-Arm

F x 1

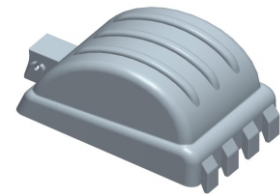

Bagger-Kopf

G x 1

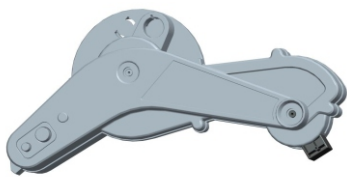

Baggerarm

H x 2

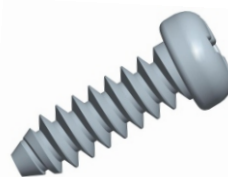

Schraube (4 x 12 mm)

I x 4

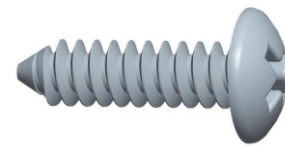

Schraube (4 x 12 mm)

J x 1



Lenkrad

K x 1

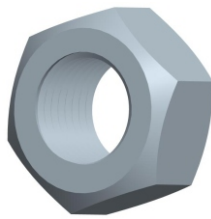

Mutter (M5)

L x 1

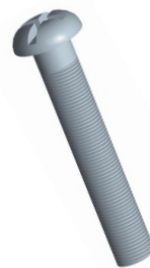
Schraube  
(5 x 25 mm)

M x 2

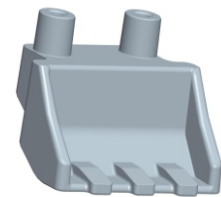

Kippschutzstütze

**HINWEIS:**

Einige Teile befinden sich unter dem Sitz, bitte nehmen Sie sie vor der Montage unter dem Sitz heraus.

Benötigtes Montagewerkzeug:



Schraubendreher (nicht enthalten)

## **⚠️ WARNUNG:**

1. ERSTICKUNGSGEFAHR-Kleine Teile.
2. Die Montage darf nur von Erwachsenen vorgenommen werden, halten Sie Kinder fern.
3. Es ist unter der direkten Aufsicht eines Erwachsenen zu verwenden.
4. Erlauben Sie jeweils nur einem Kind es zu benutzen.
5. Verwenden Sie es bitte auf einer ebenen und sauberen Oberfläche. Es sollte niemals in der Nähe von Treppen, steile Auf-/ oder Abfahrten, hügeligen Straßen, Alleen, Schwimmbadbereichen, Straßen, auf Gras oder nassen Oberflächen oder anderen Gewässern benutzt werden.
6. Vor jeder Nutzung des Spielzeugautos sollte ein Erwachsener die Schrauben aller Teile überprüfen. Ziehen Sie bitte die Schraubenkappen fest, wenn sie locker sind. Überprüfen Sie vor jeder Fahrt alle Befestigungselemente.
7. Es sollten immer Schuhe und eine geeignete Schutzausrüstung getragen werden. Während der Fahrt sollte immer ein gemäß der örtlichen Norm zugelassener Helm getragen werden, dessen Kinnriemen fest sitzt.
8. Nicht während der Dämmerung, bei Nacht oder bei eingeschränkter Sicht mit dem Produkt fahren.
9. Beachten Sie stets die örtlichen Gesetze und Vorschriften.

## **WARTUNG & PFLEGE**

- A. Bewahren Sie alle Anweisungen und Teile, die sich auf dieses Produkt beziehen, zur späteren Verwendung auf.
- B. Prüfen Sie es regelmäßig auf Beschädigungen und ob alle Schrauben fest angezogen sind.
- C. Prüfen Sie, ob der Sitz sicher befestigt ist.
- D. Schmieren Sie die Kette so oft wie nötig.

# **MONTAGEANWEISUNGEN**

**HINWEIS:** Einige Teile befinden sich unter dem Sitz, bitte nehmen Sie diese vor der Montage unter dem Sitz heraus.

## **Montage des Planierraupen-Kopfs**

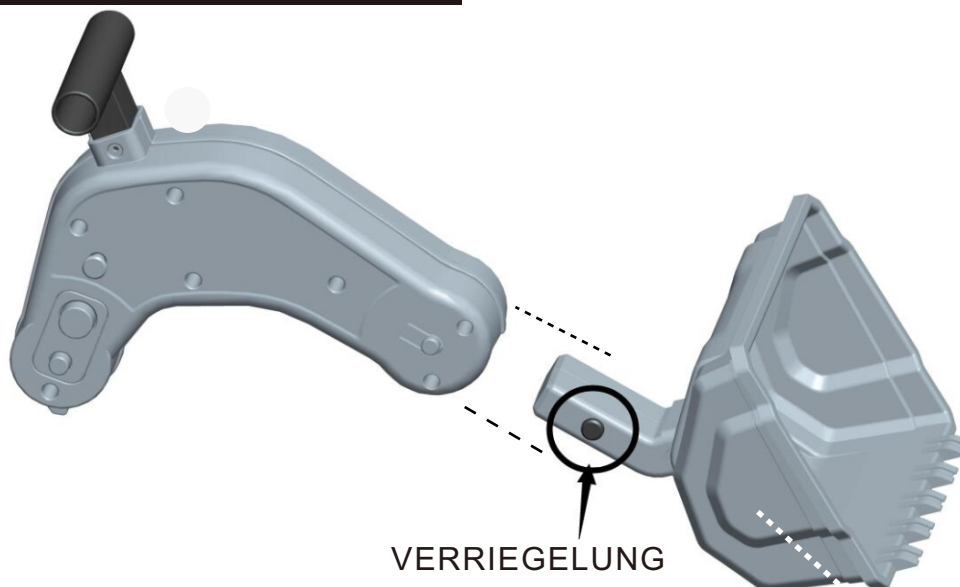

Drücken Sie die Verriegelung am Planierraupen-Kopf und setzen Sie ihn in den Planierraupen-Arm ein, wie in der Abbildung gezeigt.

**HINWEIS:** Die Straßenwalze und der Planierraupen-Kopf teilen sich einen Arm. Wenn Sie den Planierraupen-Kopf verwenden, müssen Sie die Straßenwalze demontieren.

# MONTAGEANWEISUNGEN

## Montage der Straßenwalze

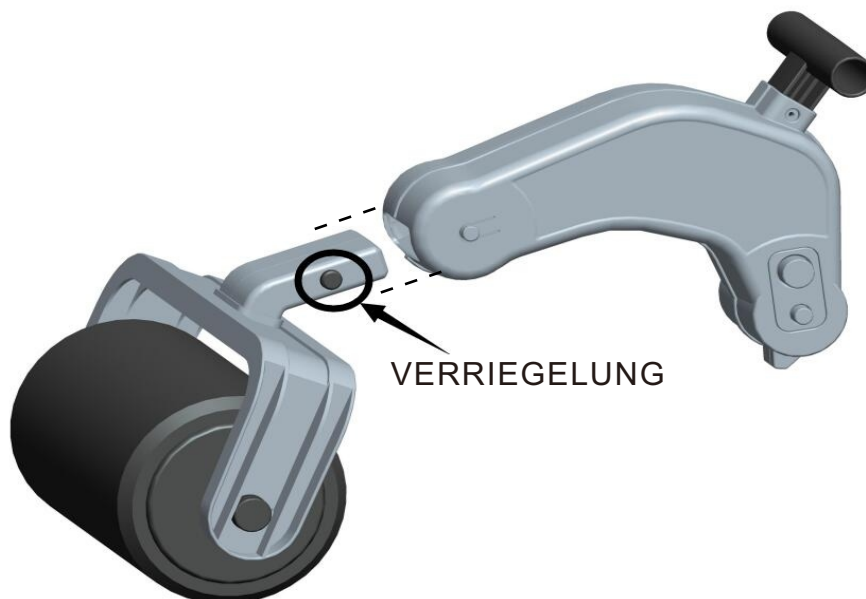

Drücken Sie die Verriegelung an der Straßenwalze und setzen Sie sie in den Straßenwalzenarm ein, wie in der Abbildung gezeigt.

**HINWEIS:** Die Straßenwalze und der Planierraupen-Kopf haben einen gemeinsamen Arm. Wenn Sie die Straßenwalze verwenden, müssen Sie den Planierraupen-Kopf abmontieren.

## Montage des Baggerarm-Schiebebügels

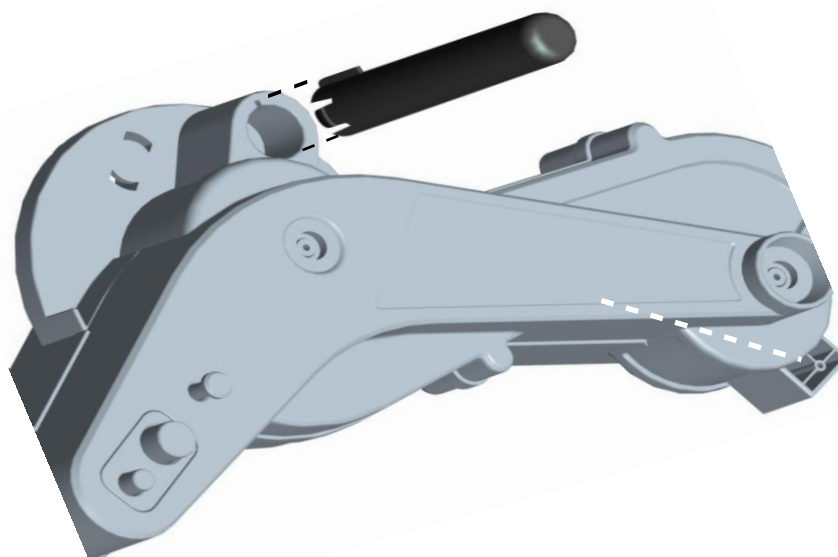

Bitte setzen Sie den linken und rechten Schiebebügel wie abgebildet in den Baggerarm ein.

# MONTAGEANWEISUNGEN

## Montage des Baggers

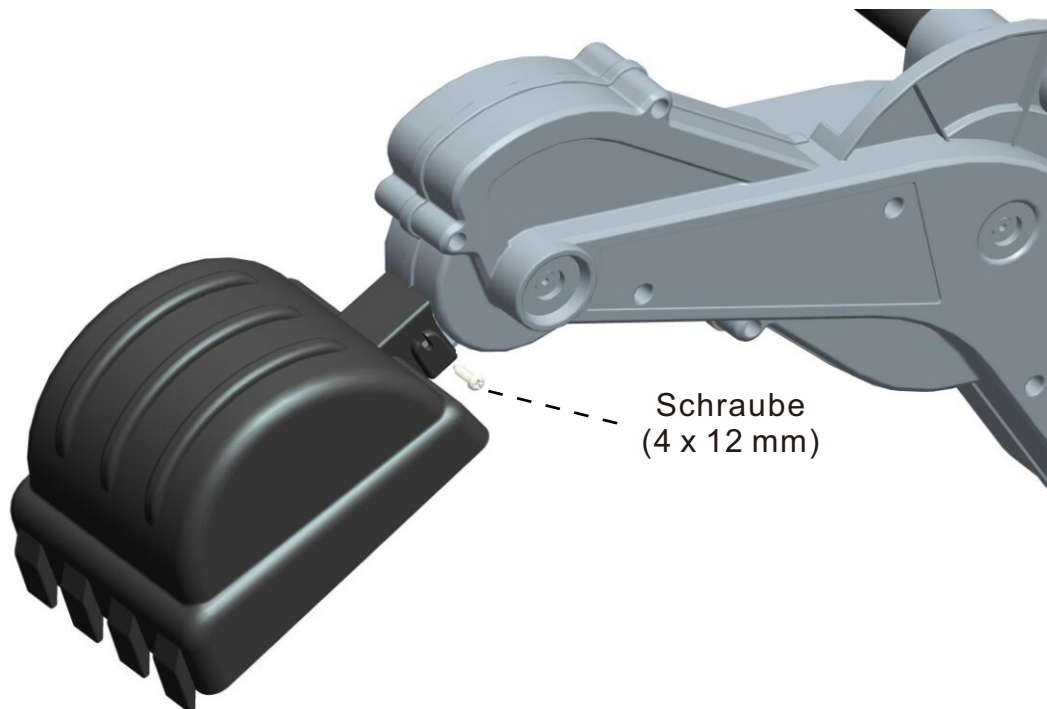

Montieren Sie den Bagger-Kopf und befestigen Sie ihn mit 2 Schrauben auf beiden Seiten, wie in der Abbildung gezeigt.

## Montage des vorderen Kippschutzes

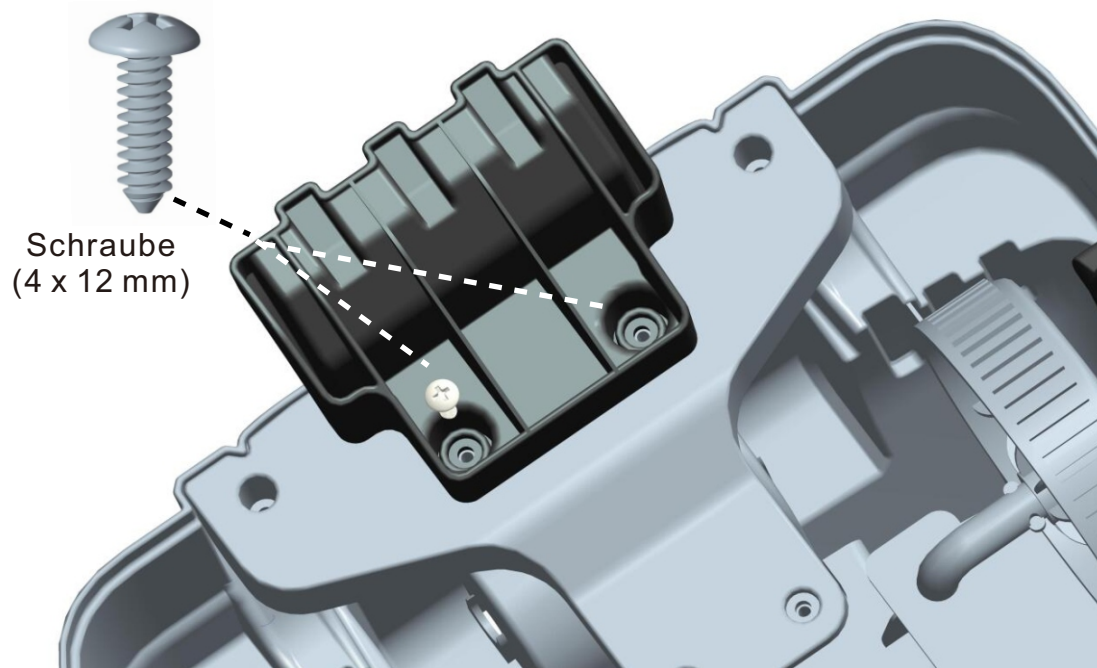

Setzen Sie die Kippstütze ein und befestigen Sie sie mit 2 Schrauben, wie in der Abbildung gezeigt.

# MONTAGEANWEISUNGEN

## Montage des hinteren Kippschutzes

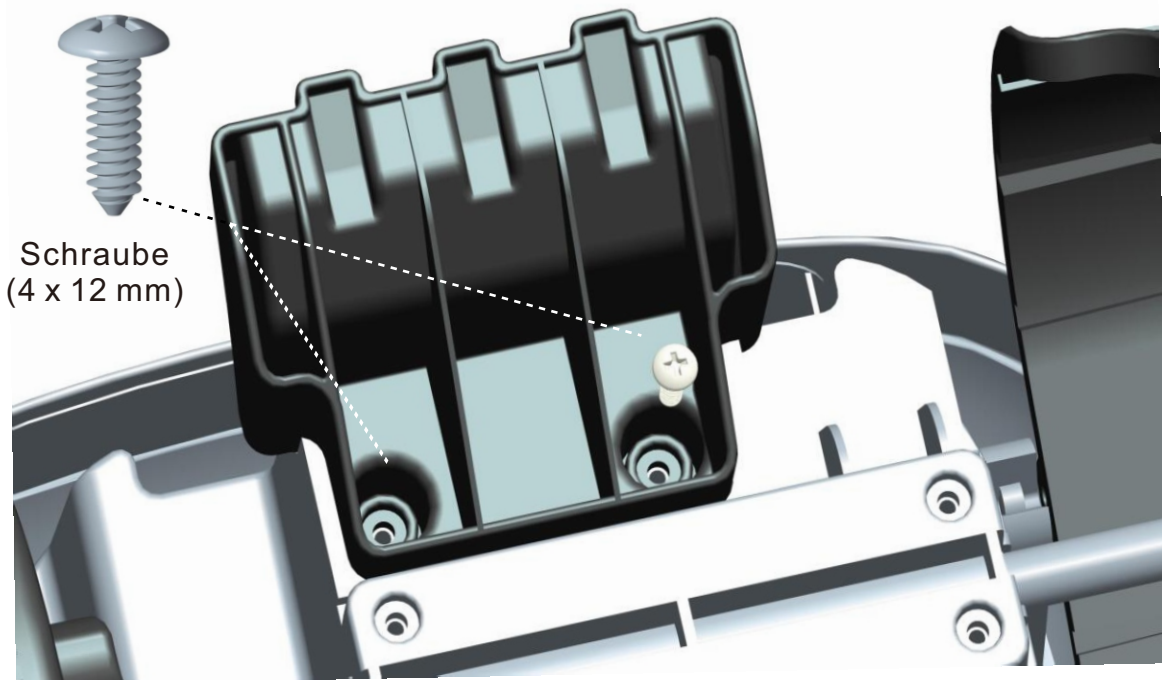

Setzen Sie die Kippstütze ein und befestigen Sie sie mit 2 Schrauben, wie in der Abbildung gezeigt.

## Montage des Lenkrads

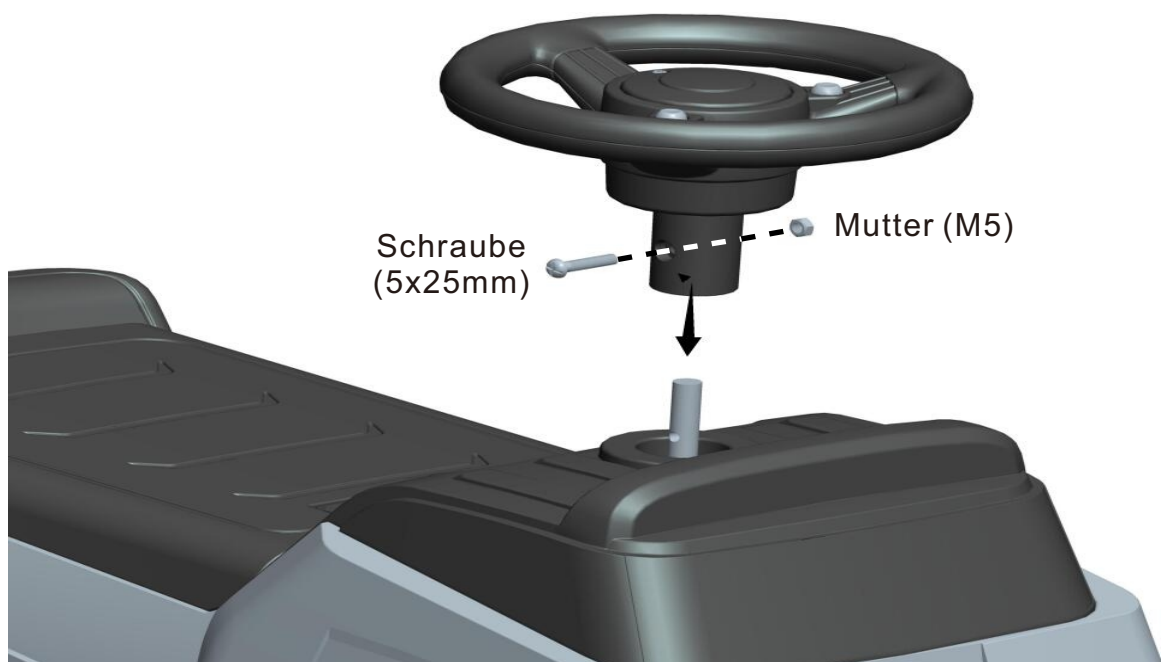

Setzen Sie das Lenkrad in die Lenksäule ein. Ziehen Sie die Schraube mit der Mutter fest.

# MONTAGEANWEISUNGEN

## Montage Planierraupen-Kopf/Bagger-Kopf/Straßenwalze

**HINWEIS:** Die Straßenwalze, der Planierraupen-Kopf und der Bagger sind in einer Karosserie untergebracht. Sie können immer nur einen von ihnen verwenden, wenn Sie möchten.

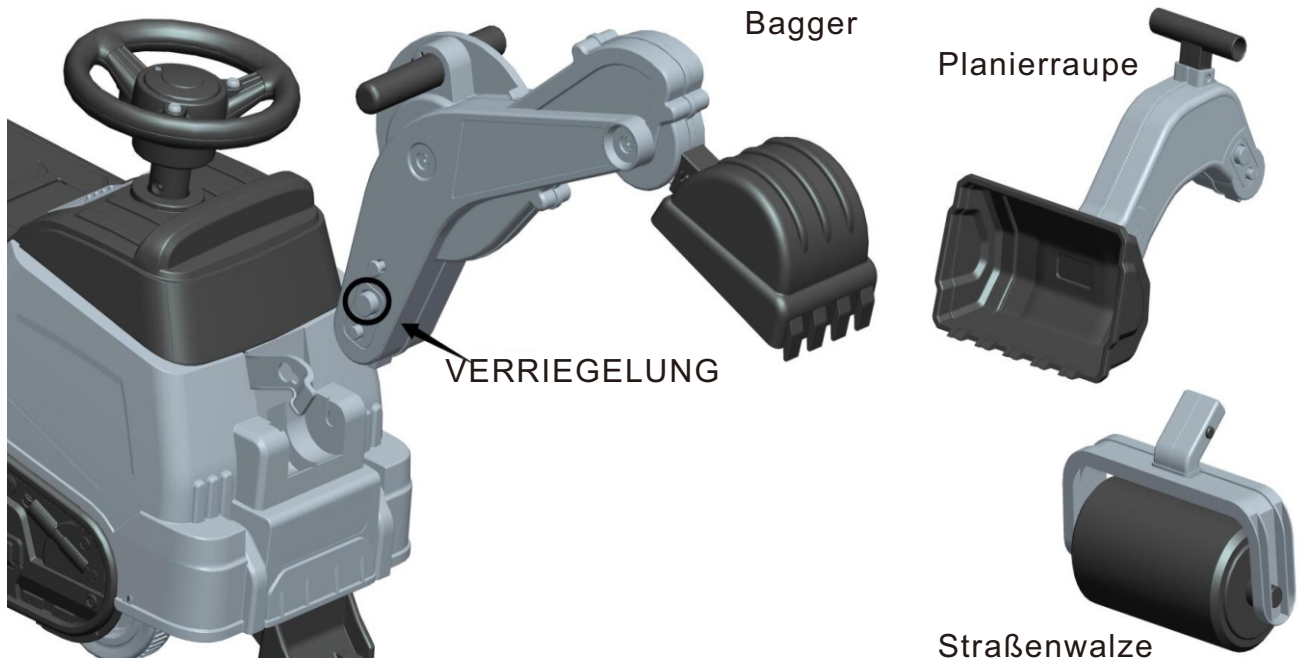

Drücken Sie die Verriegelung am Planierraupen-Arm und befestigen Sie ihn an der Karosserie, wie in der Abbildung gezeigt. Wenn Sie eine Straßenwalze oder einen Bagger verwenden, müssen Sie den Planierraupen-Kopf demontieren. Verwenden Sie die gleiche Methode, um die Straßenwalze oder den Bagger zusammenzubauen.

## Einlegen der Batterien

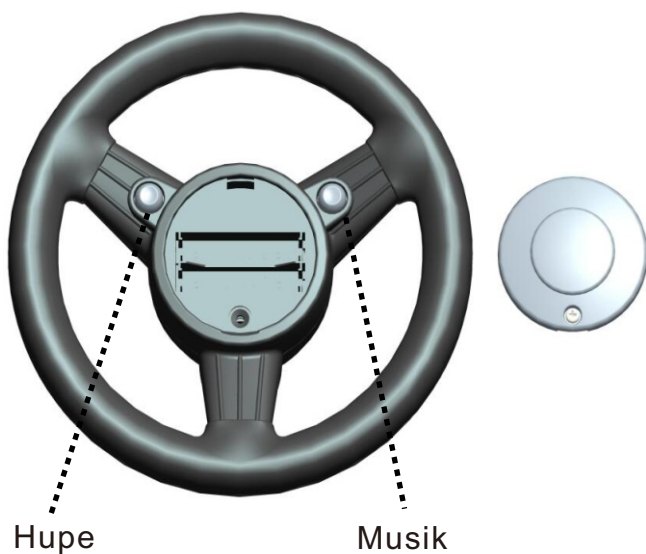

1. Für eine längere Lebensdauer verwenden Sie Alkalibatterien.
2. Lösen Sie die Schraube in der Klappe des Batteriefachs mit einem Kreuzschlitzschraubendreher und entfernen Sie die Klappe.
3. Legen Sie zwei neue AAA (LR03) Alkalibatterien ein.
4. Ersetzen Sie den Deckel des Batteriefachs und ziehen Sie die Schraube wieder fest. Nicht zu fest anziehen.

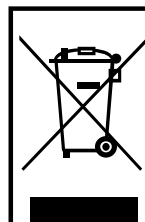

Schützen Sie die Umwelt, indem Sie dieses Produkt nicht im Hausmüll entsorgen (2012/19/EU). Erkundigen Sie sich bei Ihrer örtlichen Behörde nach Ratschlägen und Möglichkeiten zum Recycling.

# Teile-Diagramm

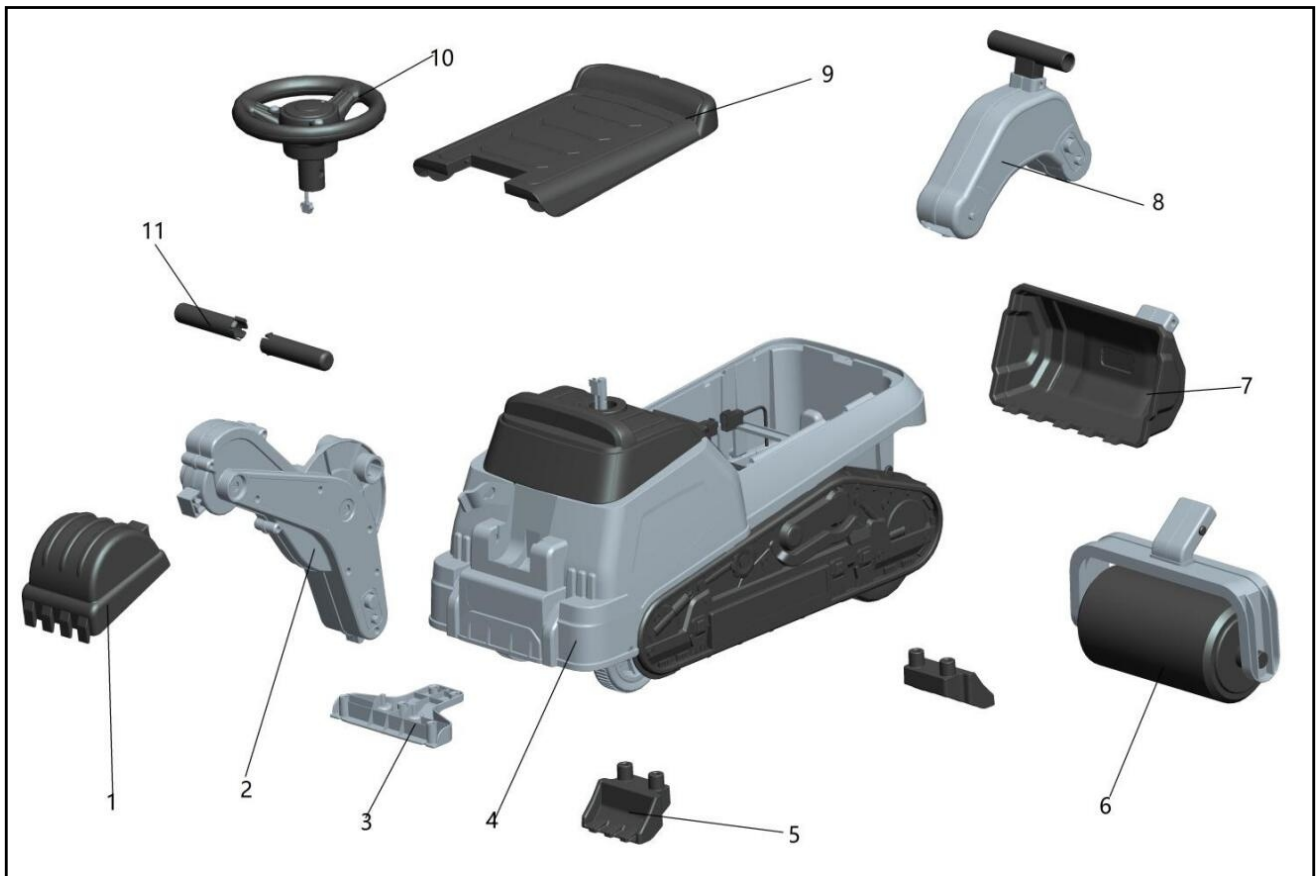

Seriennummer. Teil	Menge	Seriennummer. Teil	Menge
1. Bagger-Kopf	1	7. Planierraupen-Kopf	1
2. Baggerarm	1	8. Planierraupe/Straßenwalzenarm	1
3. Vordere Stütze	1	9. Sitz	1
4. Karosserie	1	10. Lenkrad	1
5. Kippschutzstütze	2	11. Schiebebügel	2
6. Straßenwalze	1		



**3 in 1**

## **Escavatore giocattolo multifunzione per bambini**



\* **ATTENZIONE:** Età di certificazione:18+ mesi; Peso massimo:25 kg.

**IMPORTANTE! CONSERVARE IL PRESENTE MANUALE PER FUTURO RIFERIMENTO E LEGGERLO ATTENTAMENTE**

# ISTRUZIONI DI ASSEMBLAGGIO

A x 1

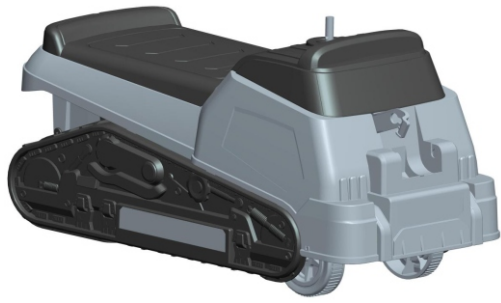

Carrozzeria

B x 2



Manopola

C x 1



Rullo compressore

D x 1

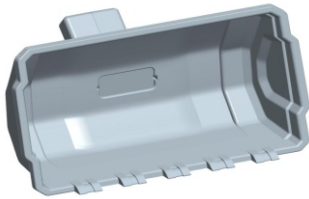

Benna ruspa

E x 1



Braccio rullo compressore/ruspa

F x 1

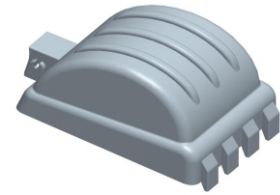

Benna escavatore

G x 1



Braccio escavatore

H x 2

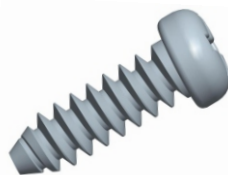

Vite (4 x 12 mm)

I x 4

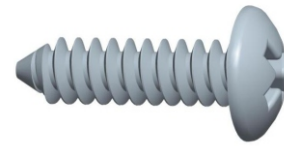

Vite (4 x 12 mm)

J x 1



Volante

K x 1

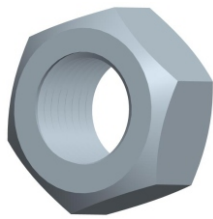

Dado (M5)

L x 1

Vite  
(5x25mm)

M x 2

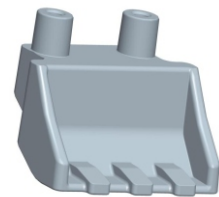

Supporto antiribaltamento

**AVVISO:**

Alcune parti si trovano sotto il sedile, si prega di estrarle da sotto il sedile prima del montaggio.

Utensili richiesti per il montaggio:



Cacciavite (non incluso)

## **⚠ AVVERTENZA:**

1. RISCHIO DI SOFFOCAMENTO — Parti piccole.
2. Consentire l'installazione solo agli adulti, tenere lontani i bambini.
3. Da utilizzare sotto la diretta supervisione di un adulto.
4. Consentire l'uso un bambino alla volta.
5. Si prega di utilizzare su una superficie in piano e pulita. Non usare mai vicino a gradini, passi carrai in pendenza, strade in collina, vicoli, piscine, strade, su erba o superfici bagnate o altre fonti d'acqua.
6. Prima di guidare ogni volta il veicolo, l'adulto dovrebbe ispezionare le viti di tutte le parti, e stringere i dadi in caso di allentamento. Stringere tutti i dispositivi di fissaggio prima di ogni viaggio.
7. Indossare sempre scarpe e dispositivi di protezione adeguati. Indossare sempre un casco approvato dalla normativa locale durante la guida, con il cinturino fissato saldamente.
8. Non guidare il prodotto al crepuscolo, di notte o in momenti di visibilità limitata.
9. Rispettare sempre le leggi e le normative locali.

## **MANUTENZIONE & CURA**

- A. Conservare tutte le istruzioni e le parti relative a questo prodotto per riferimenti futuri.
- B. Verificare regolarmente la presenza di danni e che tutte le viti siano strette saldamente.
- C. Verificare che il sedile sia fissato in sicurezza.
- D. Lubrificare la catena tutte le volte che è necessario.

# Istruzioni di assemblaggio

**AVVISO:** Alcune parti si trovano sotto il sedile, si prega di estrarle da sotto il sedile prima del montaggio.

## **Assemblaggio benna della ruspa**

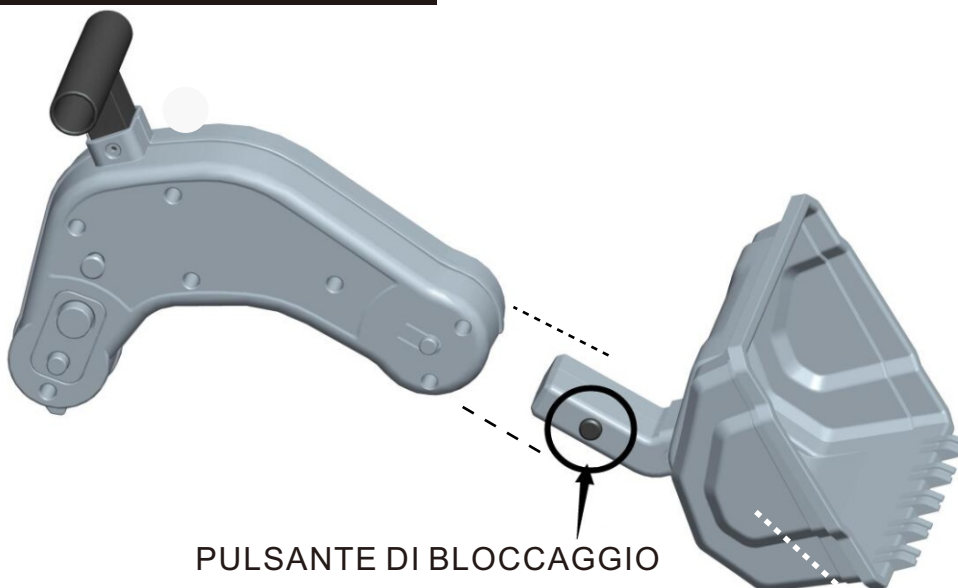

Premere il pulsante sulla benna e inserirla nel braccio dell'escavatore come mostrato in figura.

**NOTA:** il rullo compressore e la benna della ruspa condividono lo stesso braccio, se si utilizza la benna è necessario smontare il rullo compressore.

# Istruzioni di assemblaggio

## Assemblaggio rullo compressore

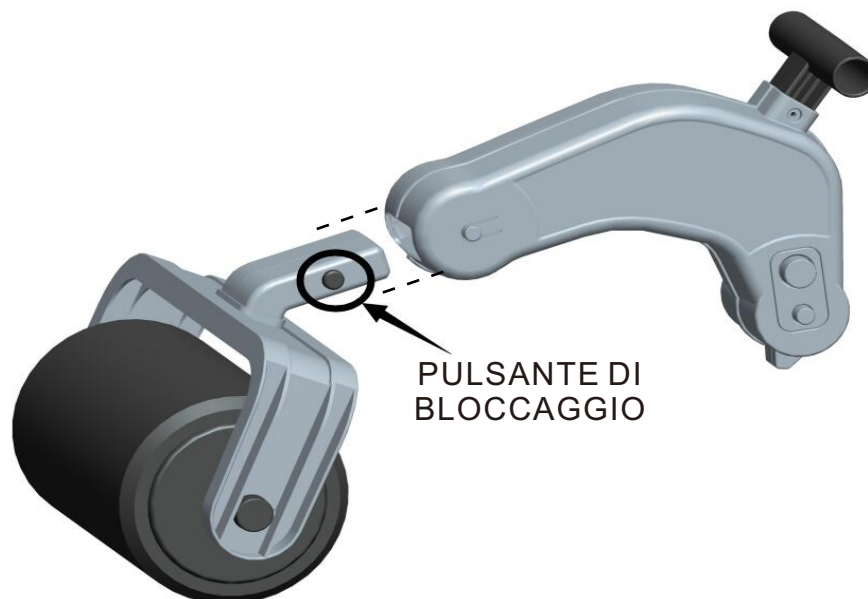

Premere il pulsante sul rullo compressore e inserirlo nel braccio dell'escavatore come mostrato in figura.

**NOTA:** il rullo compressore e la benna della ruspa condividono lo stesso braccio, se si utilizza il rullo compressore è necessario smontare la benna.

## Assemblaggio manopola del braccio dell'escavatore

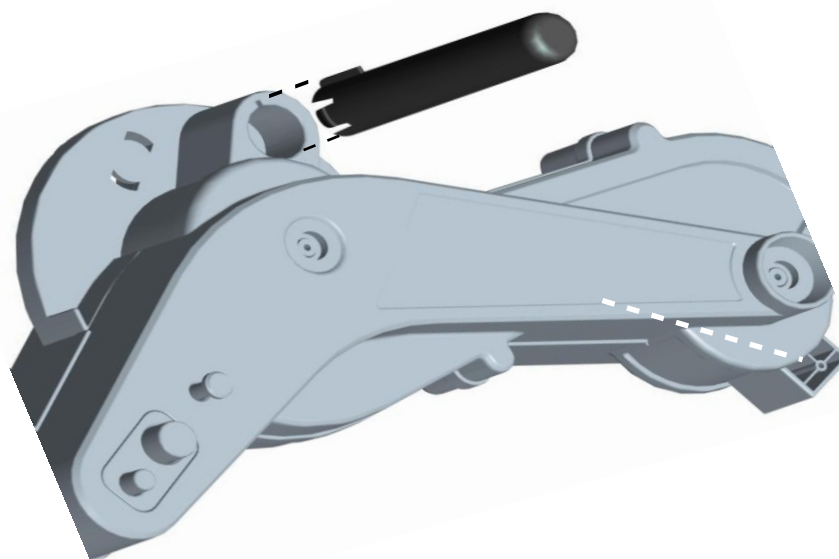

Inserire la manopola sinistra e destra nel braccio dell'escavatore come mostrato in figura.

# Istruzioni di assemblaggio

## Assemblaggio dell'escavatore

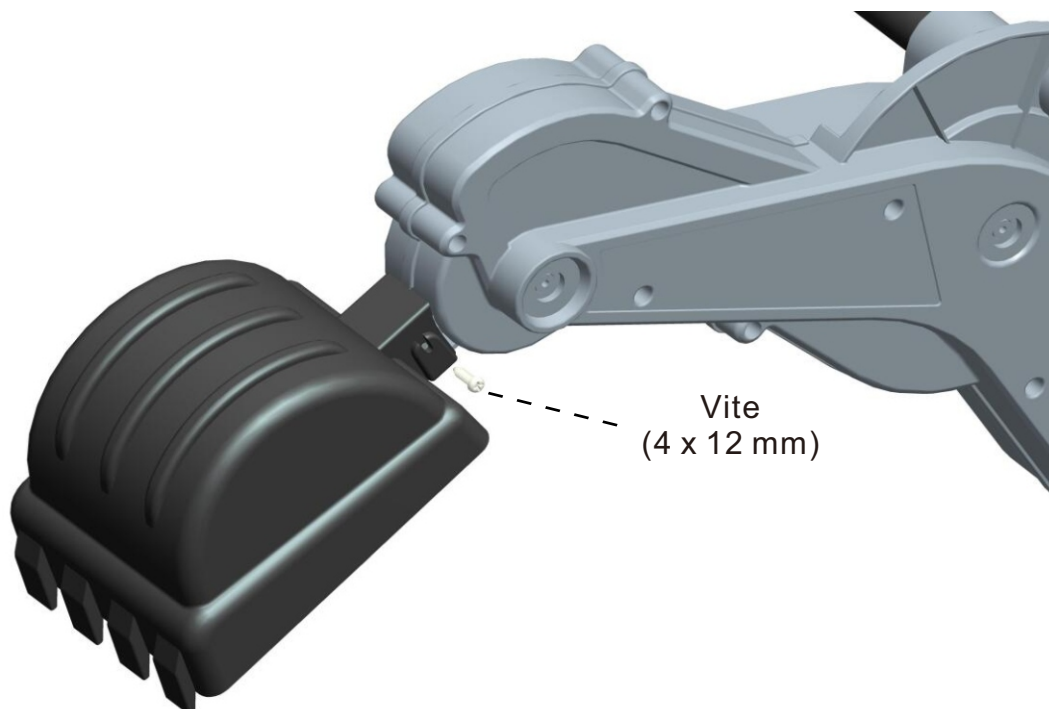

Assemblare la benna dell'escavatore e fissarla con 2 viti sui due lati come mostrato in figura.

## Assemblaggio del supporto anteriore antiribaltamento

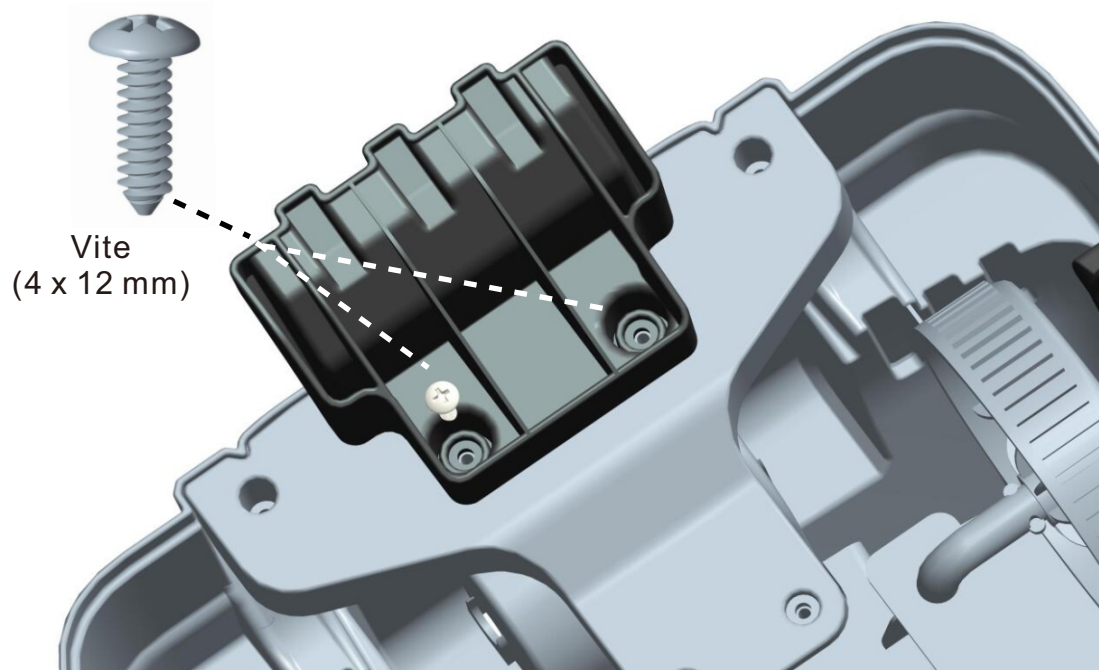

Inserire il supporto antiribaltamento e fissarlo con 2 viti come mostrato in figura.

# Istruzioni di assemblaggio

## Assemblaggio del supporto posteriore antiribaltamento

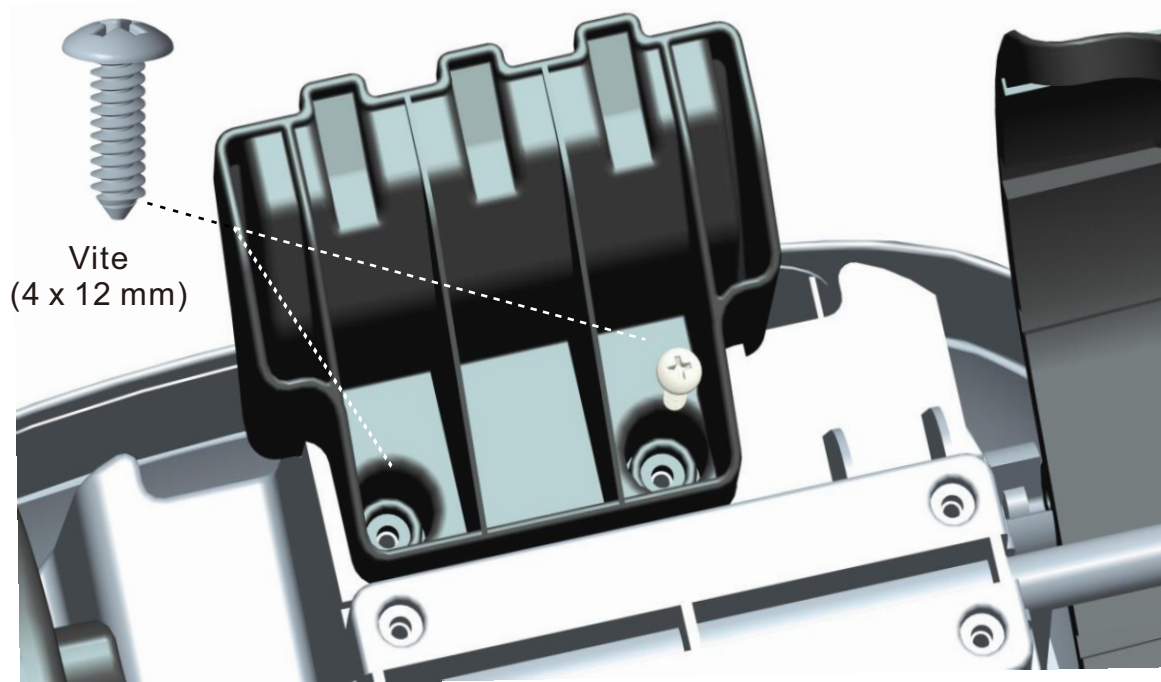

Inserire il supporto antiribaltamento e fissarlo con 2 viti come mostrato in figura.

## Assemblaggio del volante

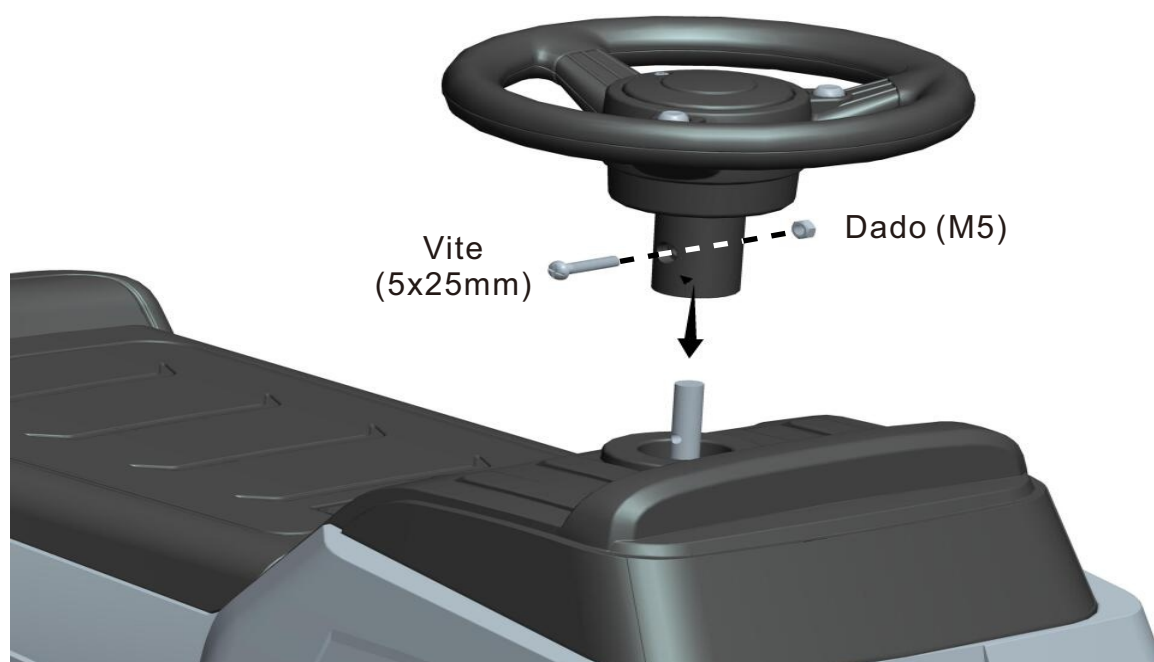

Posizionare il volante nel piantone dello sterzo. Stringere la vite con il dado.

# Istruzioni di assemblaggio

## Assemblaggio benna ruspa/benna escavatore/rullo compressore

**NOTA:** il rullo compressore, la benna della ruspa e la benna dell'escavatore condividono un unico braccio. È possibile usarne solo uno alla volta come preferito.

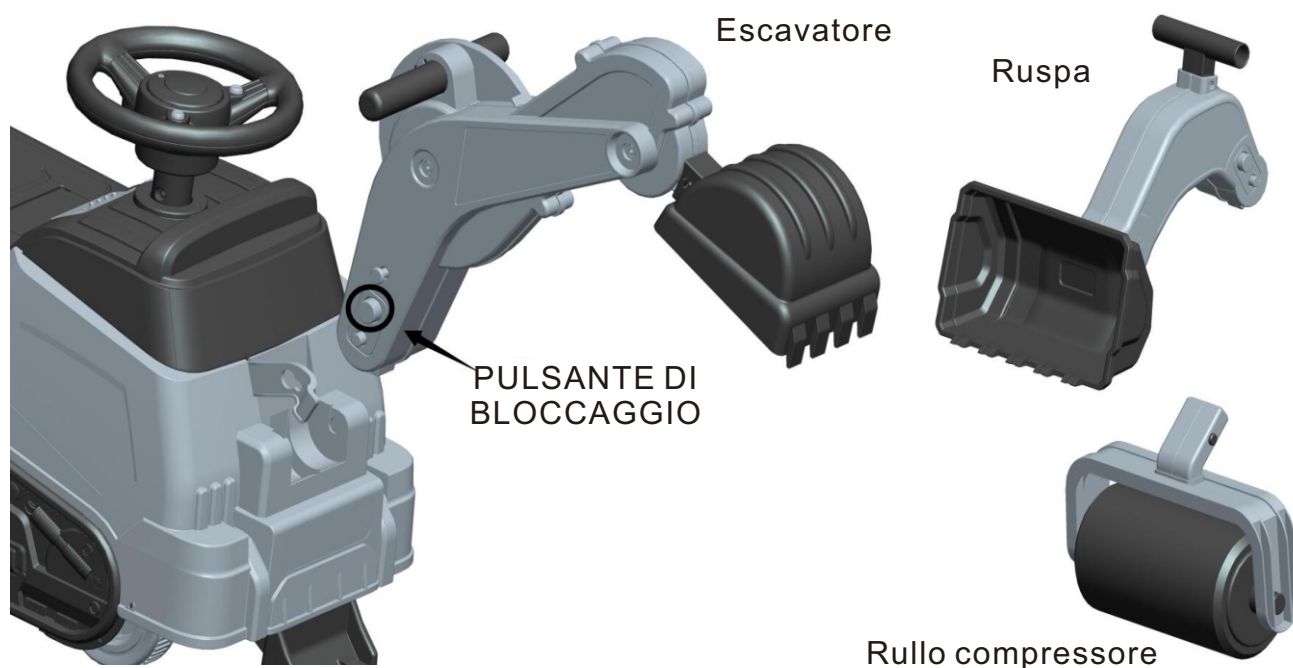

Premere il pulsante sulla benna della ruspa e inserirla nel veicolo come mostrato in figura. Se si utilizza il rullo compressore o la benna dell'escavatore, è necessario smontare prima la benna della ruspa. Utilizzare lo stesso metodo per montare il rullo compressore o la benna dell'escavatore.

## Installazione delle batterie

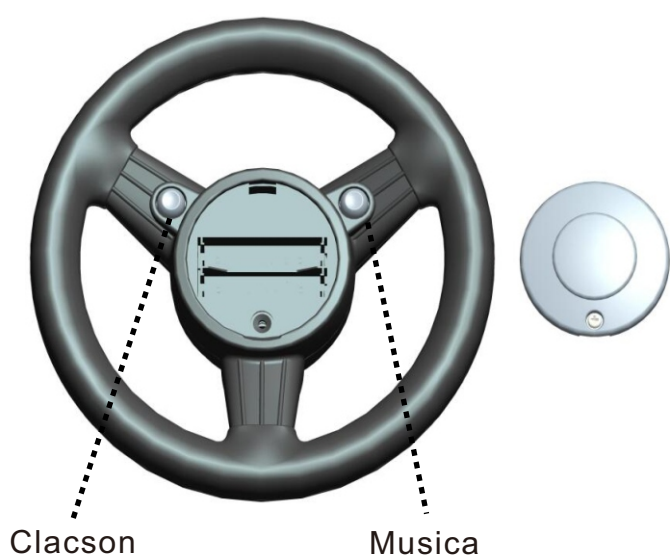

1. Per una maggiore durata, utilizzare batterie alcaline.
2. Allentare la vite nel coperchio del vano batteria con un cacciavite Phillips e rimuovere il coperchio.
3. Inserire due batterie alcaline AAA (LR03) nuove.
4. Richiudere il coperchio del vano batteria e stringere la vite. Non stringere eccessivamente.

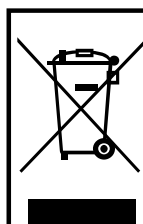

Proteggere l'ambiente non smaltendo questo prodotto con i rifiuti domestici (2012/19/UE). Controllare con l'autorità locale per ottenere consigli sullo smaltimento e i contatti delle strutture per il riciclaggio.

# Diagramma delle Parti

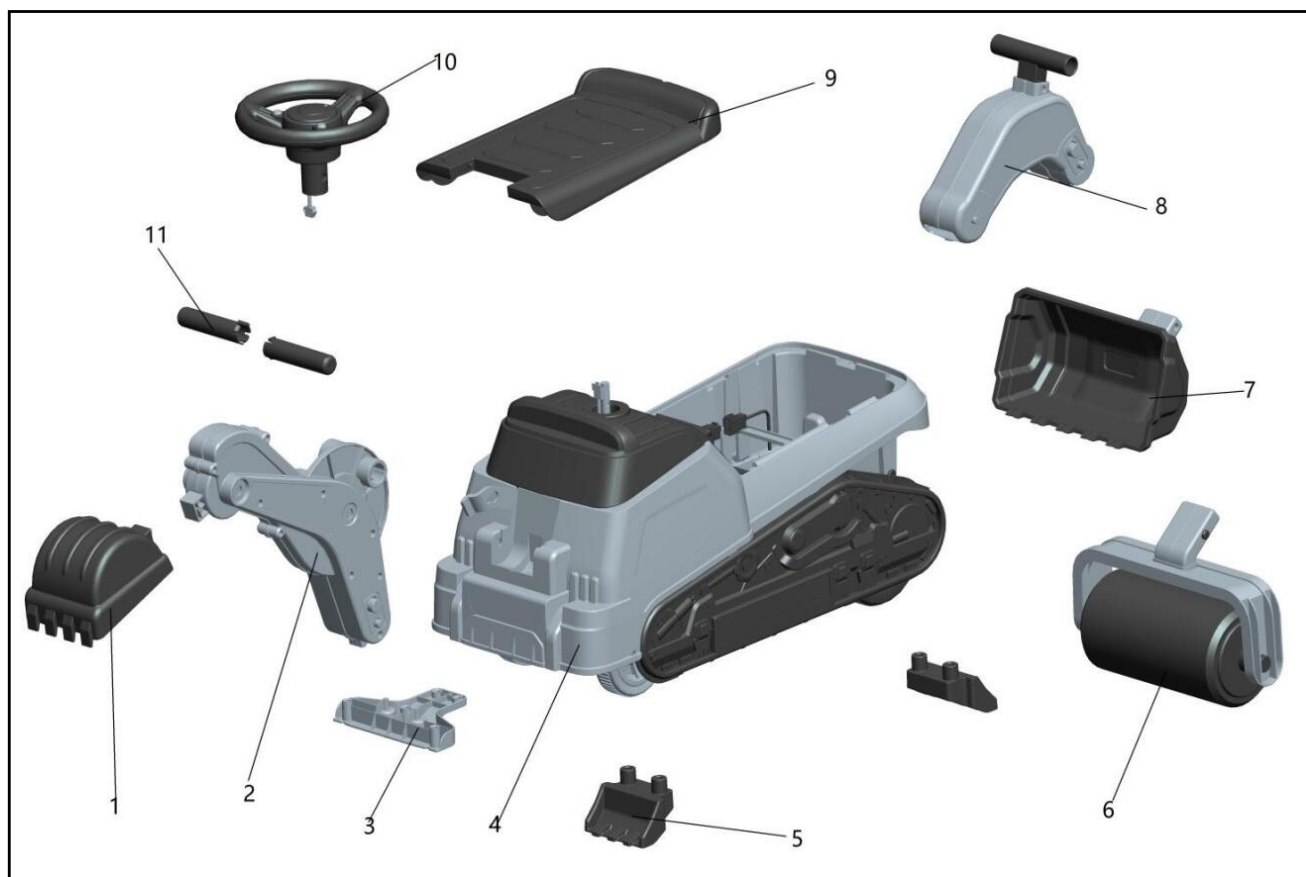

No. Parte	Quantità	No. Parte	Quantità
1. Benna escavatore	1	7. Benna ruspa	1
2. Braccio escavatore	1	8. Braccio ruspa/rullo compressore	1
3. Supporto anteriore	1	9. Sedile	1
4. Carrozzeria veicolo	1	10. Volante	1
5. Supporto antiribaltamento	2	11. Manopola	2
6. Rullo compressore	1		



**UK**

If you have any questions, please contact our customer care center.

Our contact details are below:



0044-800-240-4004



enquiries@mhstar.co.uk

**IMPORTER ADDRESS:**

MH STAR UK LTD  
Unit 27, Perivale Park,  
Horsenden lane South  
Perivale, UB6 7RH  
MADE IN CHINA

**FR**

Si vous avez la moindre question, veuillez contacter notre centre d'assistance à la clientèle.

Nos coordonnées sont les suivantes:



0033-1-84166106



aosom@mhfrance.fr

Importé par:

MH France  
2, rue Maurice Hartmann  
92130 Issy-les-Moulineaux  
France  
Fabriqué en Chine

**DE**

Wenn Sie Fragen haben, wenden Sie sich bitte an unser Kundendienstzentrum.

Unsere Kontaktdaten stehen unten:



0049-0(40)-88307530



service@aosom.de

**ADRESSE DES IMPORTEUR:**

MH Handel GmbH  
Wendenstraße 309  
D-20537 Hamburg  
Germany  
IN CHINA HERGESTELLT

**IT**

In caso di dubbio, si prega di contattare il nostro centro assistenza clienti.

I nostri dettagli di contatto sono di seguito:



0039-0249471447



clienti@aosom.it

IMPORTATO DA:

AOSOM Italy srl  
Centro Direzionale Milanofiori  
Strada 1 Palazzo F1  
20057 Assago (MI)  
P.I.: 08567220960  
FATTO IN CINA

