

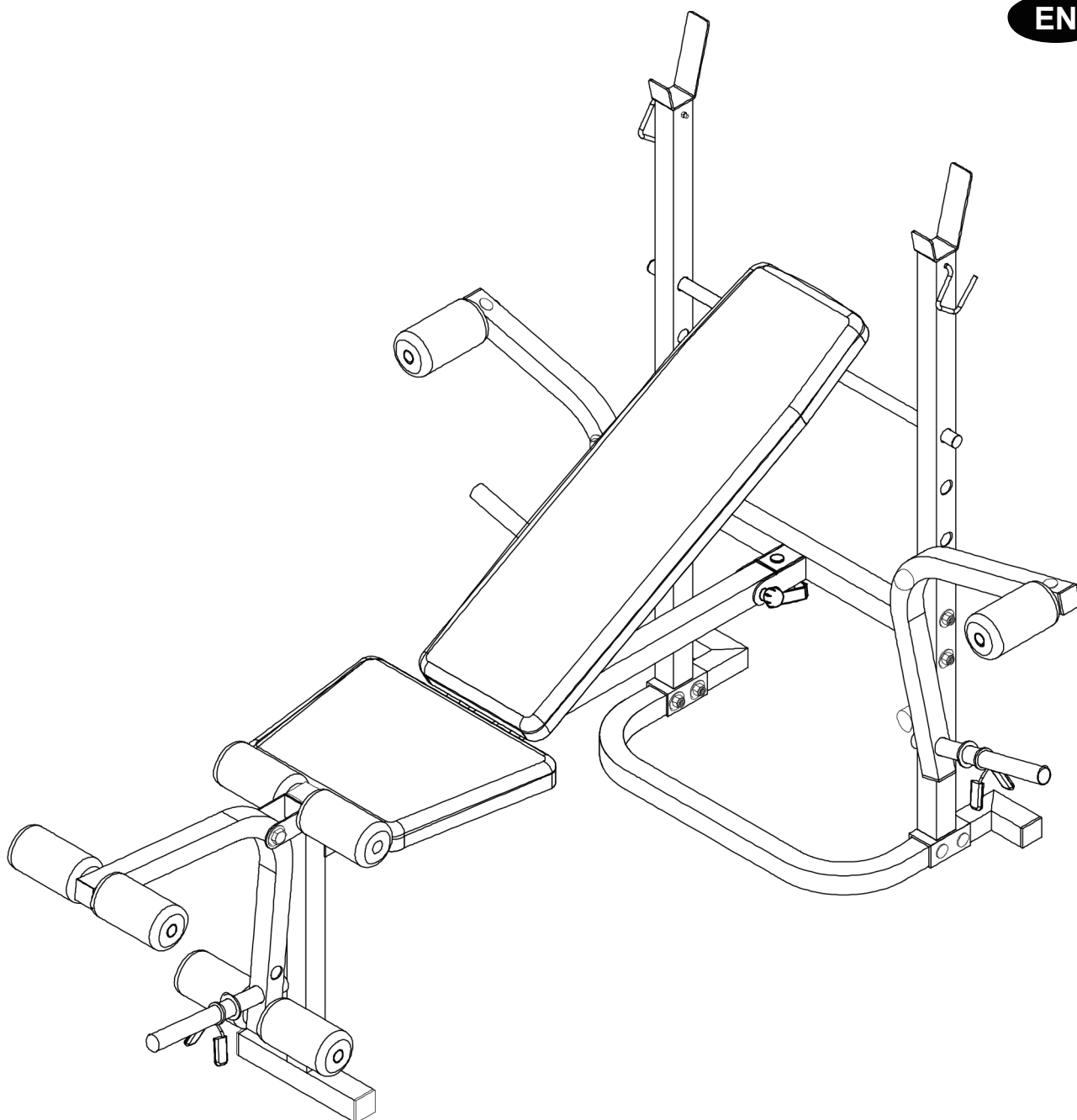

IN230800273V01_UK_FR_ES_IT

A91-054

EN



IMPORTANT, RETAIN FOR FUTURE REFERENCE: READ CAREFULLY

ASSEMBLY INSTRUCTION



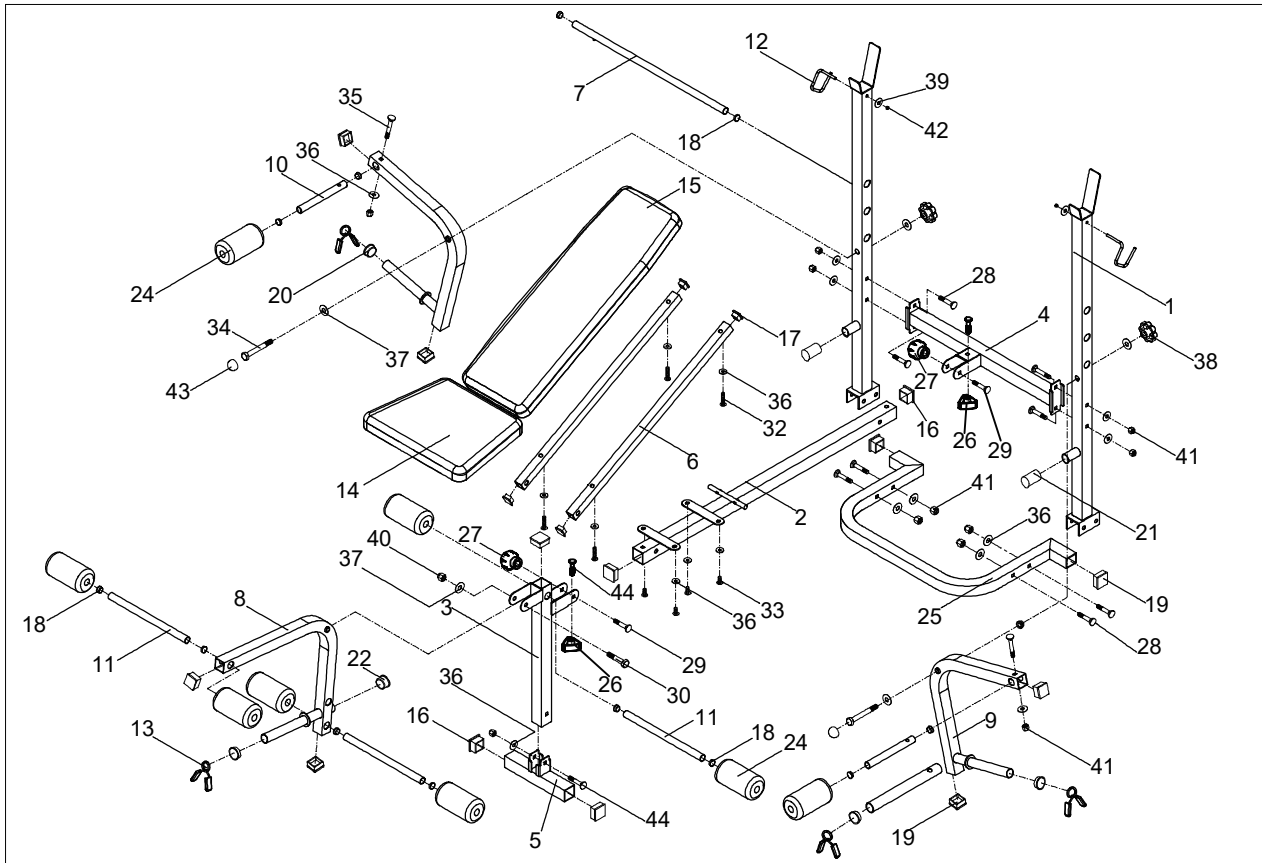





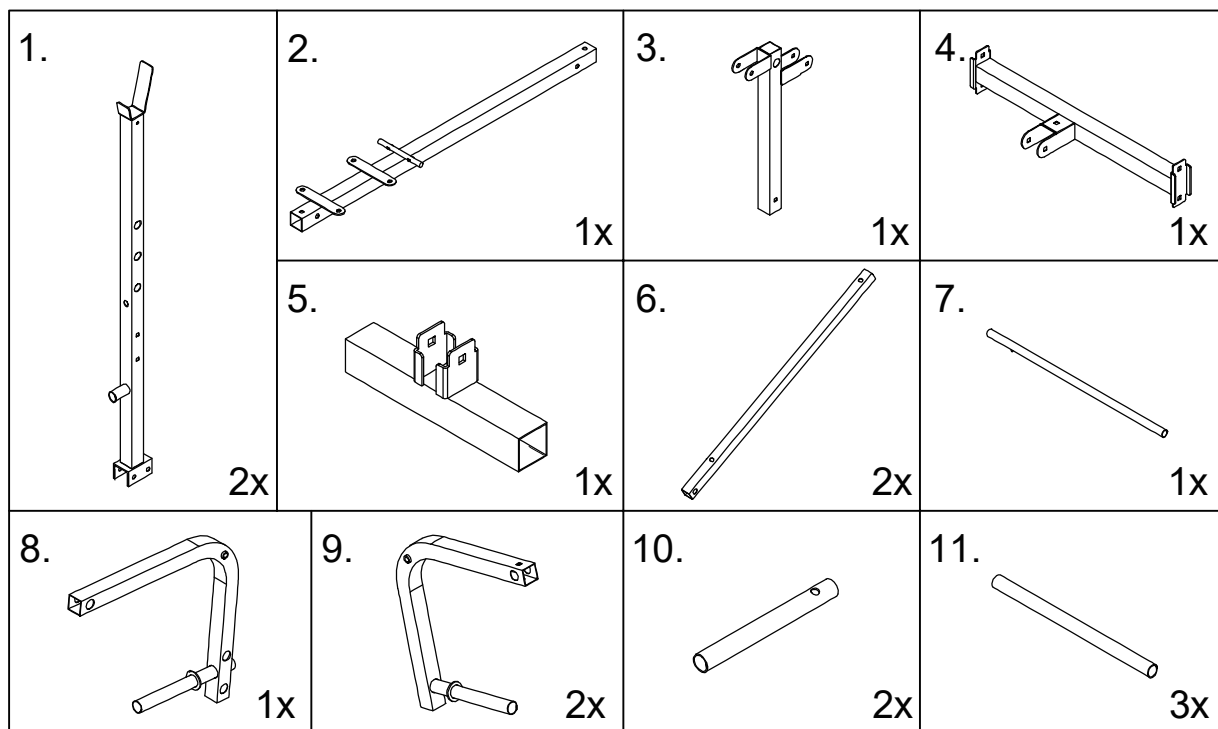



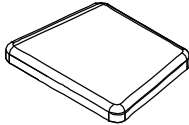
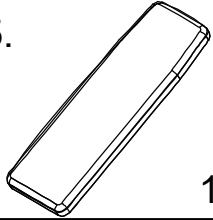







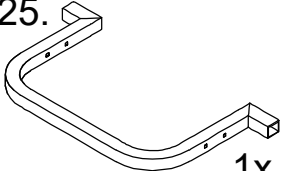



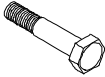

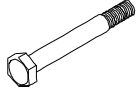
PART LIST:



No.	DESCRIPTION	NUMBER
1	Upright	2x
2	Main beam	1x
3	Front upright	1x
4	Cross beam	1x
5	Front Stabilizer	1x
6	Pivot Bar	2x
7	Cross bar	1x
8	Leg extension bracket	1x
9	Fly arm	2x
10	Foam tube	2x
11	Foam tube	3x
12	Fix locking	2x
13	Spring locking	3x
14	Seat	1x
15	Backrest	1x
16	End cap	5x
17	End cap	4x
18	End cap	10x
19	End cap	8x
20	End cap	7x

21	Protect cap	2x
22	Protect cap	1x
24	Foam	8x
25	“U” Rear stabilizer	1x
26	Knob	2x
27	Knob	2x
28	Screw 8 x 50 mm	8x
29	Screw 10 x 60 mm	2x
30	Screw 10 x 60 mm	1x
32	Screw 8 x 40 mm	4x
33	Screw 8 x 20 mm	4x
34	Screw 10 x 120 mm	2x
35	Screw 8 x 45 mm	2x
36	Washer 8 x 16 x 1,5 mm	19x
37	Washer 10 x 20 x 2 mm	5x
38	Knob	2x
39	Washer 6 x 16 x 1 mm	2 x
40	Nut M10	1x
41	Nut M8	11x
42	Nut M6	2x
43	Protect cap	2x
44	Screw 8 x 55 mm	3x



12.  2x	13.  3x	14.  1x	15.  1x
16.  Pre Assembled 5x	17.  Pre Assembled 4x	18.  Pre Assembled 10x	19.  Pre Assembled 8x
20.  Pre Assembled 7x	21.  Pre Assembled 2x	22.  Pre Assembled 1x	
24.  8x	25.  1x	26.  2x	27.  2x
28.  M8x50 9x	29.  M10x60 2x	30.  M10x60 1x	32.  M8x40 4x
33.  M8x20 4x	34.  M10x120 2x	35.  M8x45 2x	36.  M8 19x
37.  M10 5x	38.  2x	39.  M6 2x	40.  M10 1x
41.  M8 11x	42.  M6 2x	43.  2x	44.  M8x55 3x

ASSEMBLY

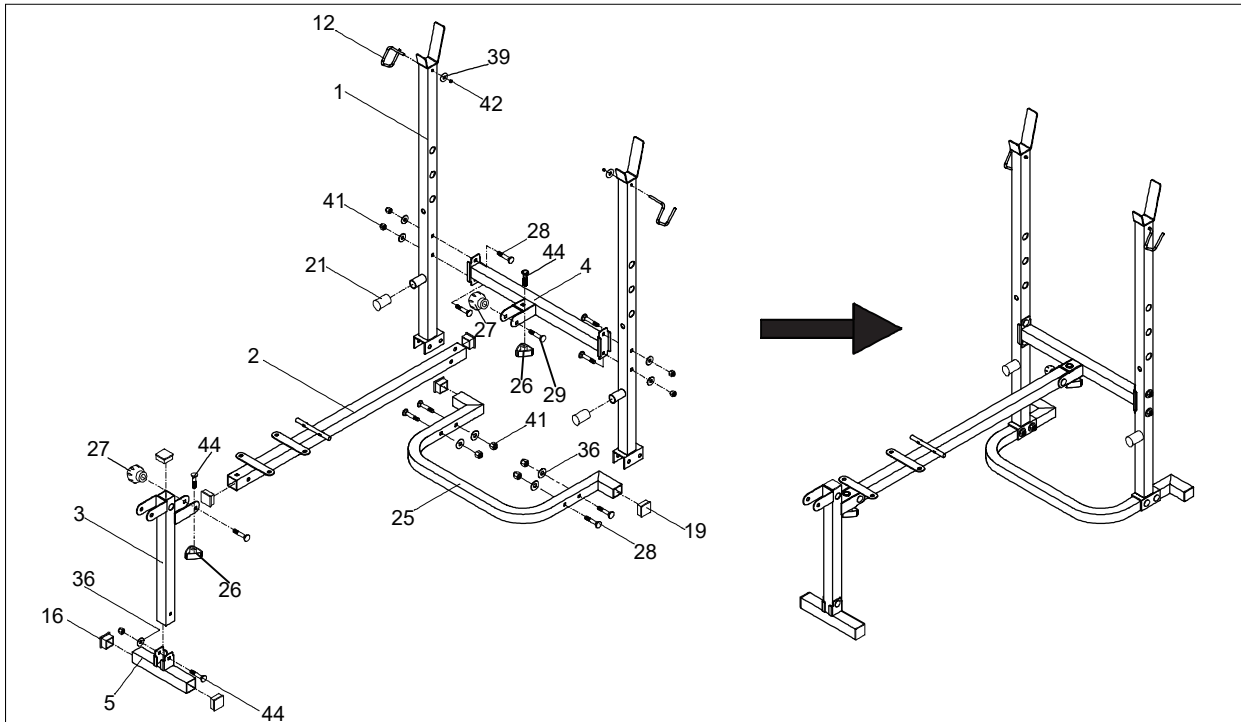

STEP 1

Fix the two uprights (1) to the “U” rear stabilizer (25) use 4 sets of screw (28), washer (36) and nut (41), connect the cross beam (4) to the two uprights (1) use 4 sets of screw (28), washer (36) and nut (41), attach the main beam (2) to the center of the cross beam (4) use one set of screw (29), knob (27) and one set of screw (44), knob (26). Then fix the front upright (3) to the front stabilizer (5) use one set of screw (44), washer (36) and nut (41), and connect the front upright (3) to the main beam (2) use one set of screw (29), knob (27) and one set of screw (44), knob (26).

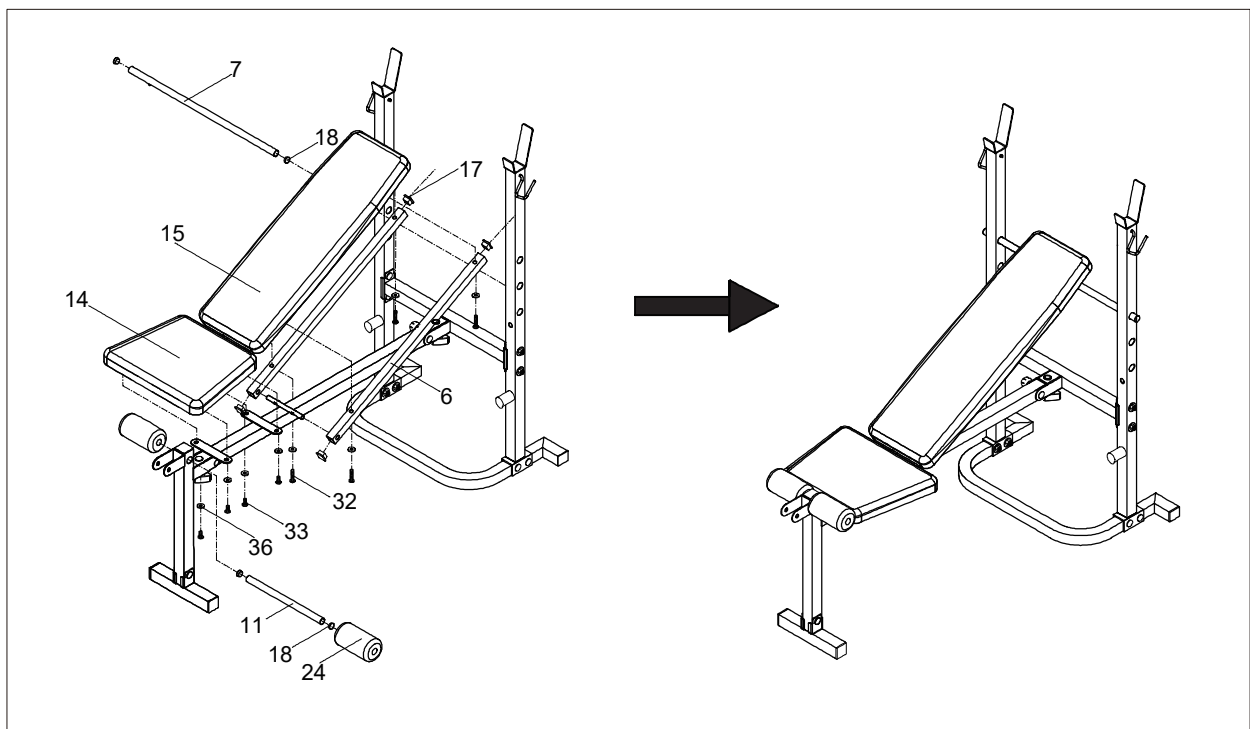

STEP 2

Insert the cross bar (7) to the hole of the two uprights (1), attach the pivot bar (6) to the main beam (2), fix the backrest (15) on the pivot bar (6) use 4 sets of screw (32) and washer (36), then fix the seat (14) on the main beam (2) use 4 sets of screw (33) and washer (36), insert the foam tube (26) to the front upright (3) and attach the foam (27) to the foam tube (26).

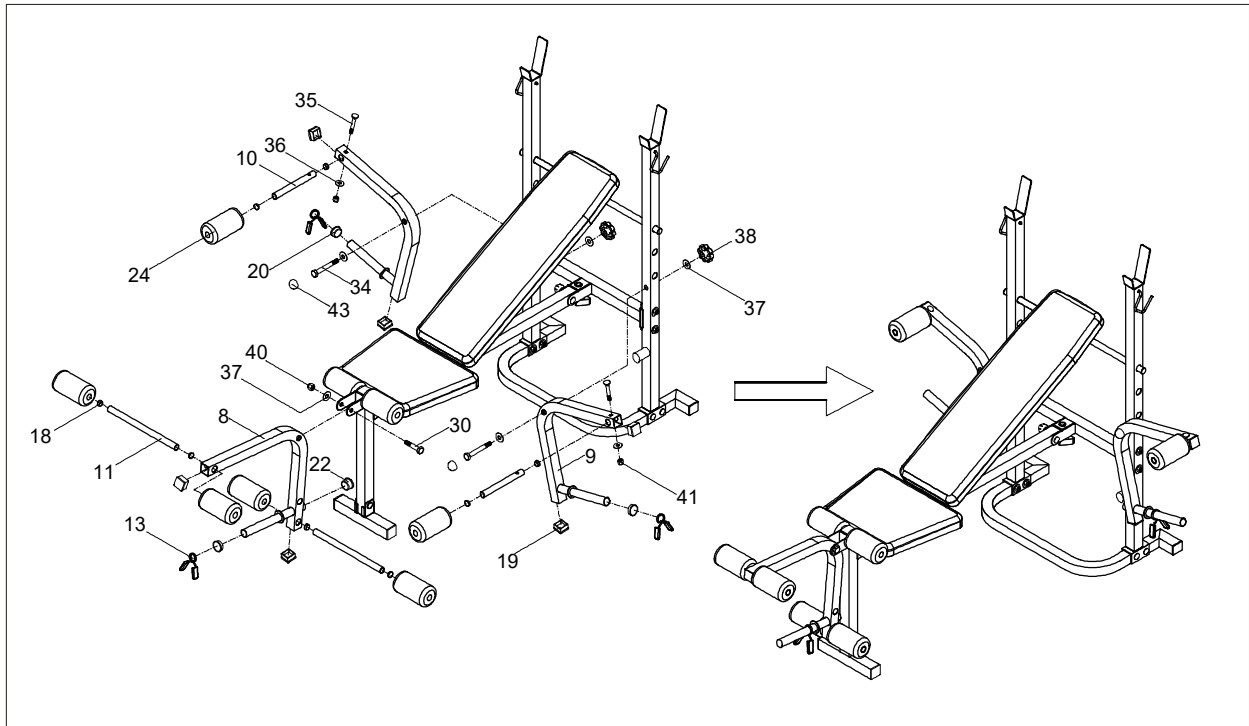

STEP 3

Attach the foam (24) to the foam tube (10), insert the foam tube to the fly arm (9) use one set of screw (35), washer (36) and nut (41), then fix the two fly arms to the two uprights (1) use 2 sets of screw (34), washer (37), and knob (38), and attach the protect cap (43) on the screw (30).

Fix the leg extension bracket (8) to the front upright (3) use one set of Screw (30), washer (37) and nut (40), insert the two foam tubes (11) to the leg extension bracket (8), then attach the foam (24) to the foam tube (11).

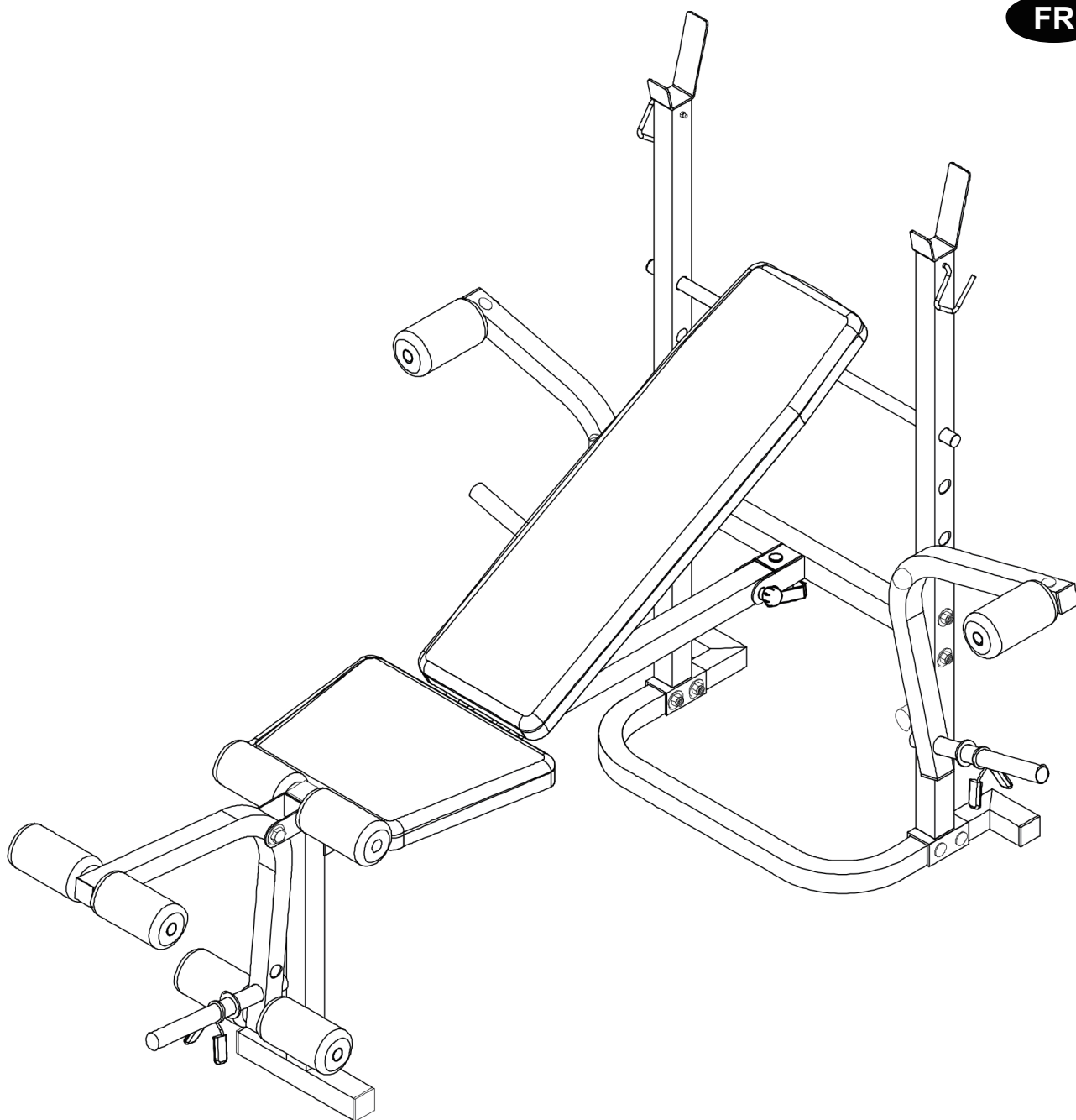

IMPORTANT - CONSERVEZ CES INFORMATIONS
POUR VOTRE CONSULTATION ULTÉRIEURE: LISEZ ATTENTIVEMENT

INSTRUCTIONS D'ASSEMBLAGE



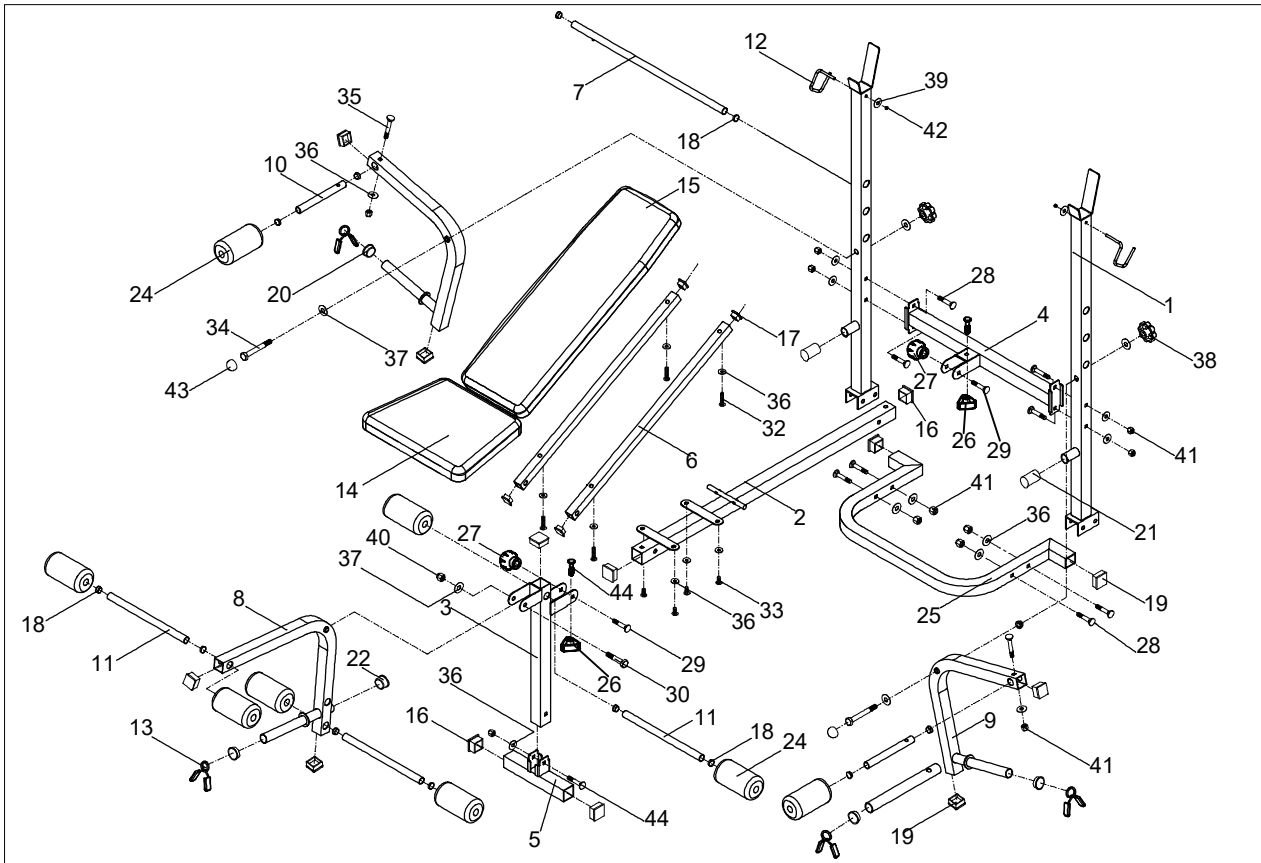





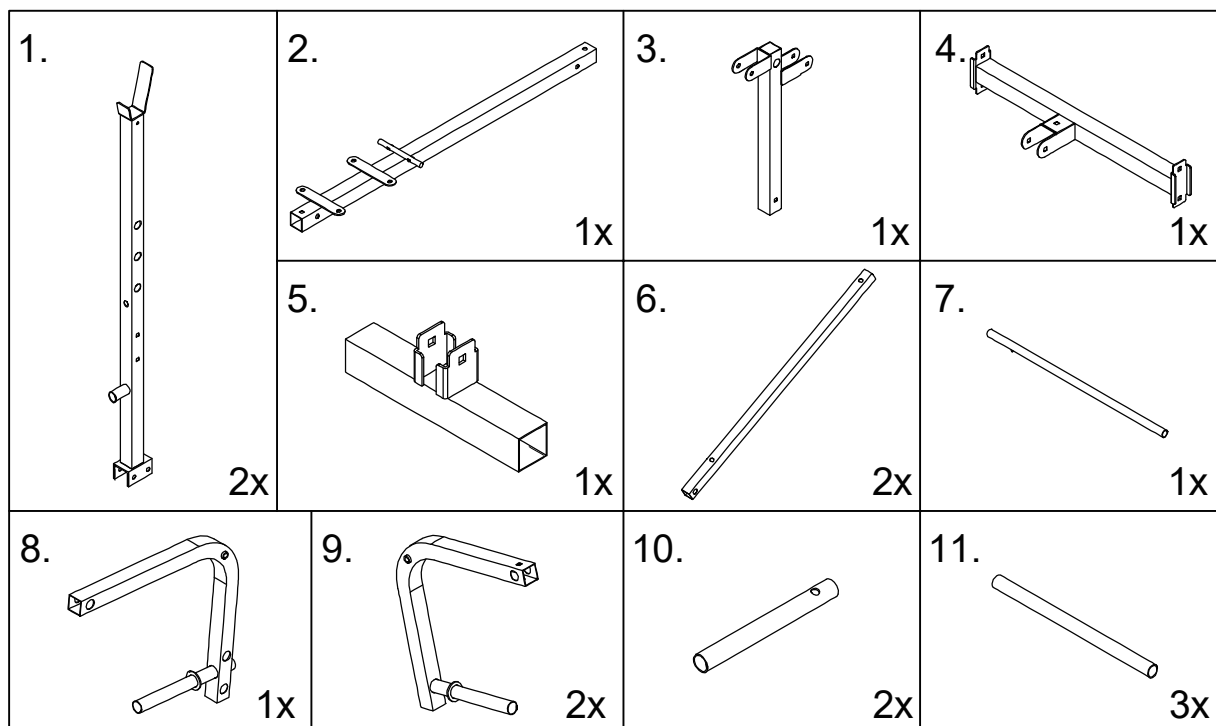



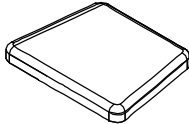
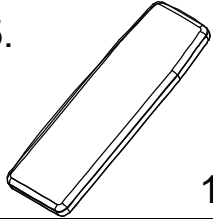







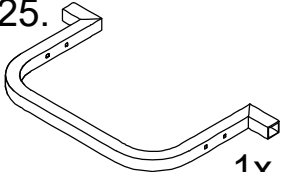



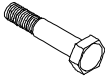

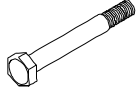
Liste de pièces:



No.	La description	Numéro
1	Vertical	2x
2	Faisceau principal	1x
3	Support avant	1x
4	Barre transversale	1x
5	Stabilisation avant	1x
6	Barre pivot	2x
7	Barre transversale	1x
8	Support d'extension de jambe	1x
9	Bras de mouche	2x
10	Tube en mousse	2x
11	Tube en mousse	3x
12	Fixer le verrouillage	2x
13	Verrouillage à ressort	3x
14	Siège	1x
15	Dossier	1x
16	Capuchon d'extrémité	5x
17	Capuchon d'extrémité	4x
18	Capuchon d'extrémité	10x
19	Capuchon d'extrémité	8x

20	Capuchon d'extrémité	7x
21	Capuchon de protection	2x
22	Capuchon de protection	1x
24	Mousse	8x
25	"U" stabilisateur arrière	1x
26	bouton	2x
27	bouton	2x
28	Vis 8 x 50 mm	8x
29	Vis 10 x 60 mm	2x
30	Vis 10 x 60 mm	1x
32	Vis 8 x 40 mm	4x
33	Vis 8 x 20 mm	4x
34	Vis 10 x 120 mm	2x
35	Vis 8 x 45 mm	2x
36	Rondelle 8x16x1,5mm	19x
37	Rondelle 10 x 20 x 2 mm	5x
38	Bouton	2x
39	Rondelle 6 x 16 x 1 mm	2x
40	écrou M10	1x
41	écrou M8	11x
42	écrou M6	2x
43	Capuchon de protection	2x
44	Vis 8 x 55 mm	3x



12.  2x	13.  3x	14.  1x	15.  1x
16.  Pré assemblé 5x	17.  Pré assemblé 4x	18.  Pré assemblé 10x	19.  Pré assemblé 8x
20.  Pré assemblé 7x	21.  Pré assemblé 2x	22.  Pré assemblé 1x	
24.  8x	25.  1x	26.  2x	27.  2x
28.  M8x50 9x	29.  M10x60 2x	30.  M10x60 1x	32.  M8x40 4x
33.  M8x20 4x	34.  M10x120 2x	35.  M8x45 2x	36.  M8 19x
37.  M10 5x	38.  2x	39.  M6 2x	40.  M10 1x
41.  M8 11x	42.  M6 2x	43.  2x	44.  M8x55 3x

Assemblée

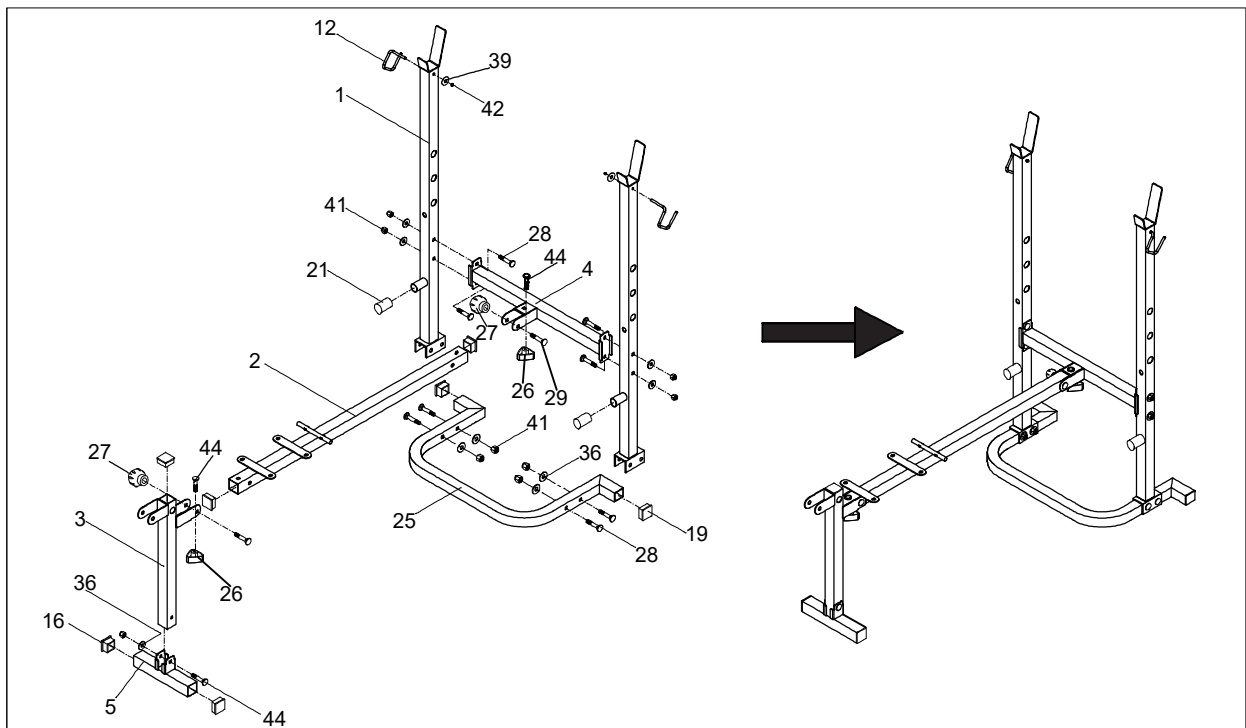

ÉTAPE 1

Fixez les deux montants (1) au stabilisateur arrière "U" (25) utilisez 4 ensembles de vis (28), la rondelle (36) et l'écrou (41), reliez la traverse (4) aux deux montants (1) Utilisez 4 ensembles de vis (28), rondelle (36) et écrou (41), fixer le faisceau principal (2) au centre de la traverse (4) utiliser un jeu de vis (29), le bouton (27) et Un jeu de vis (44), le bouton (26). Ensuite, fixez le montant avant (3) au stabilisateur avant (5) utilisez un jeu de vis (44), la rondelle (36) et l'écrou (41), et connectez le support avant (3) à l'utilisation du faisceau principal (2) Un ensemble de vis (29), le bouton (27) et un jeu de vis (44), le bouton (26).

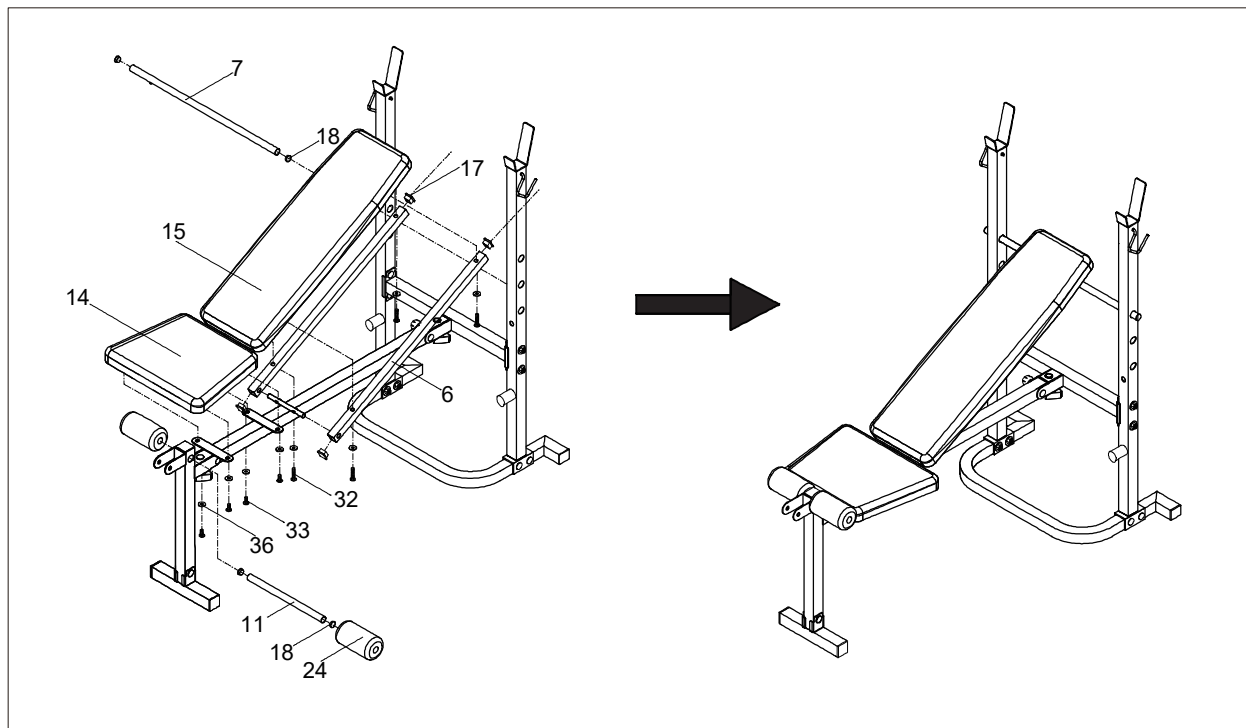

ÉTAPE 2

Insérez la barre transversale (7) sur le trou des deux montants (1), fixez la barre de pivotement (6) au faisceau principal (2), fixez le dossier (15) sur la barre de pivotement (6), utilisez 4 ensembles de vis (32) et l'écrou (36), puis fixez le siège (14) sur le faisceau principal (2) utilisez 4 ensembles de vis (33) et la rondelle (36), Insérer le tube en mousse (26) sur le montant avant (3) et attachez la mousse (27) au tube en mousse (26).

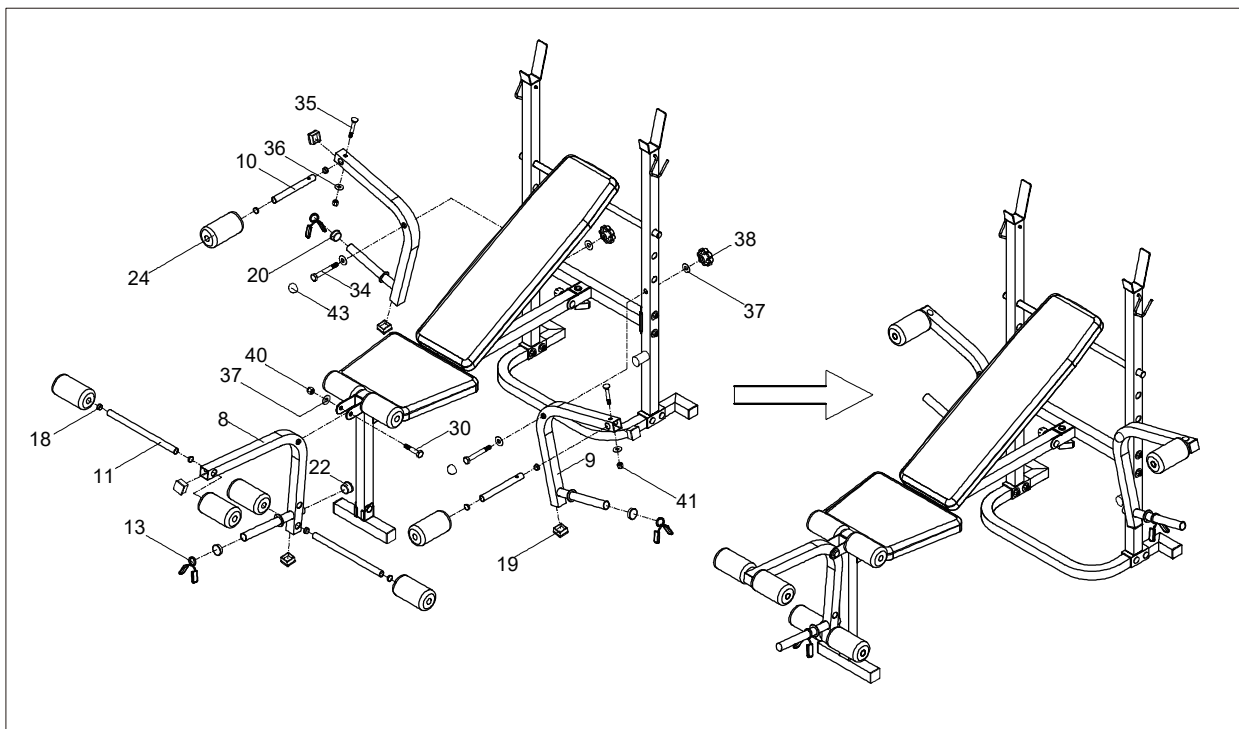

ÉTAPE 3

Fixez la mousse (24) au tube de mousse (10), insérez le tube de mousse dans le bras de la mouche (9) utilisez un jeu de vis (35), la rondelle (36) et l'écrou (41), puis fixez les deux bras de mouche Sur les deux montants (1), utilisez 2 jeux de vis (34), la rondelle (37) et le bouton (38) et fixez le capuchon de protection (43) sur la vis (30).

Fixez le support d'extension de jambe (8) au montant avant (3) utilisez un ensemble de vis (30), lavez (37) et écrou (40), insérez les deux tubes en mousse (11) sur le support d'extension de jambe (8) , Puis attachez la mousse (24) au tube de mousse (11).

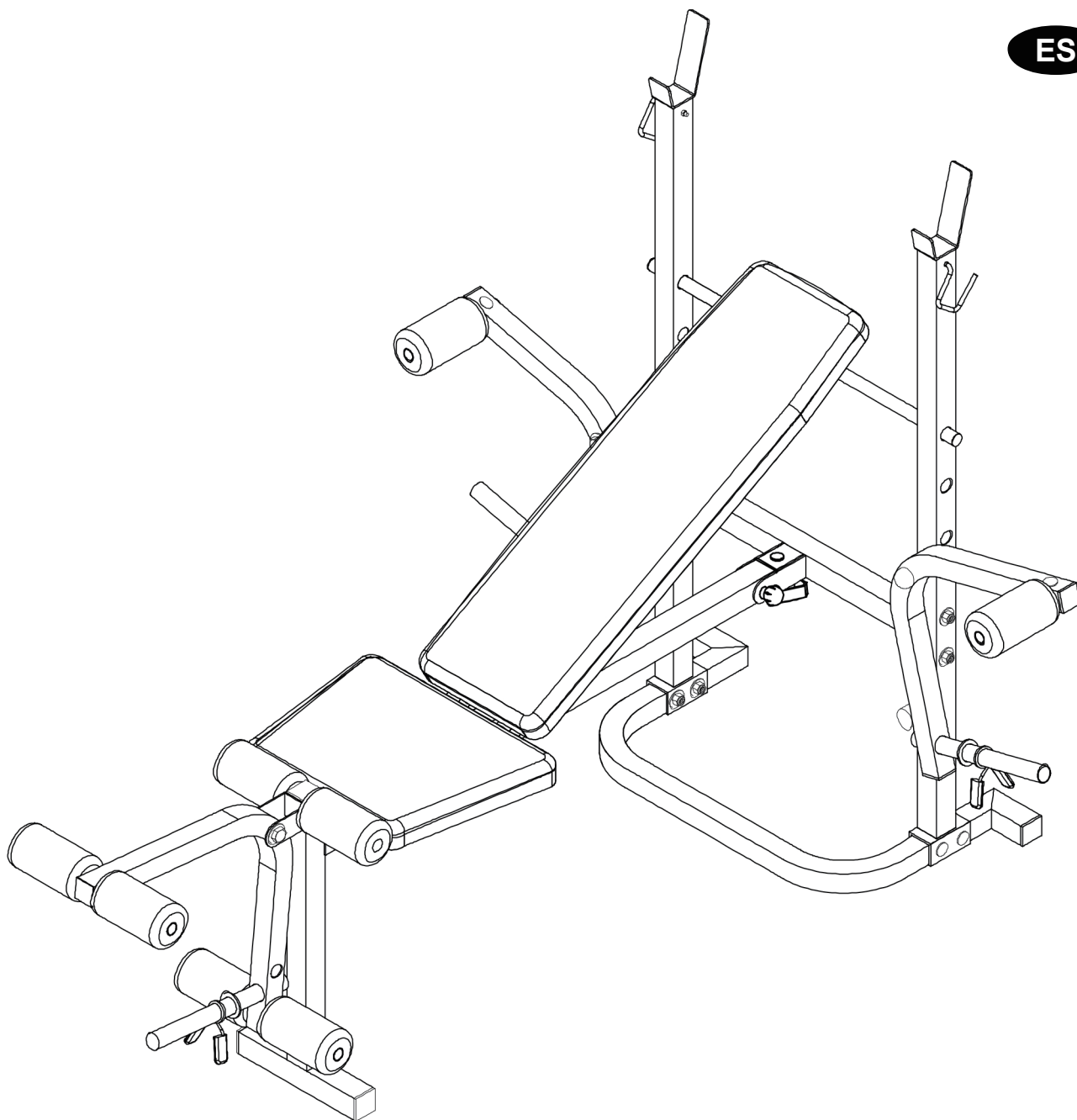

IMPORTANTE - CONSERVE ESTA INFORMACIÓN
PARA SU CONSULTA POSTERIOR: LEER DETALLADAMENTE

INSTRUCCIONES DE MONTAJE

LISTA DE PIEZAS

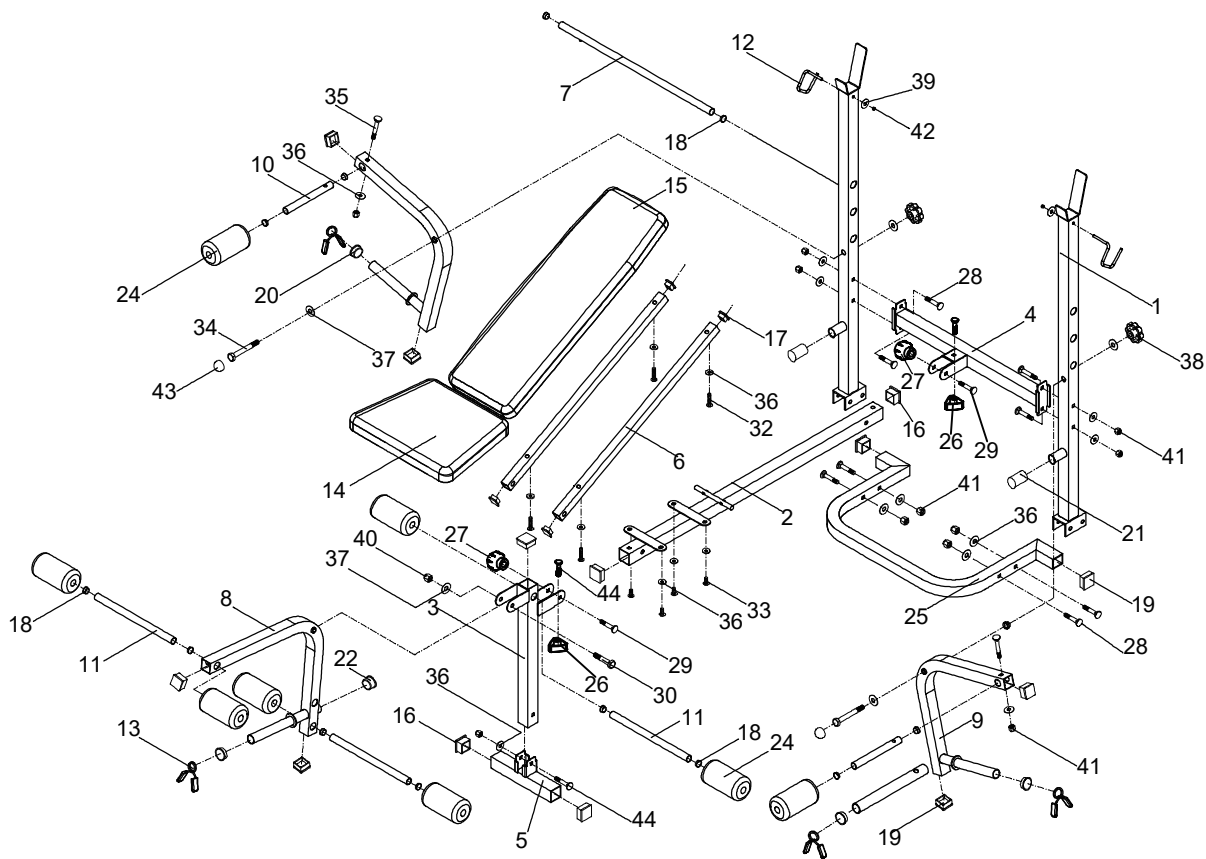







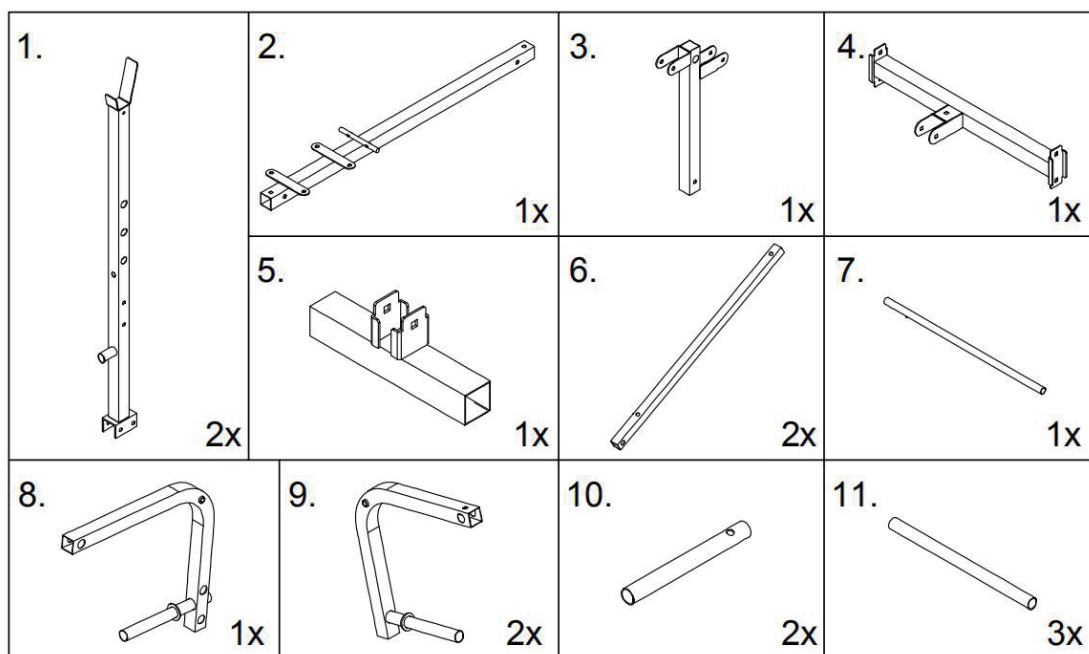



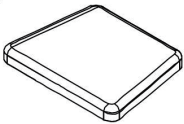
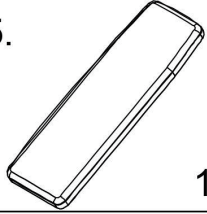







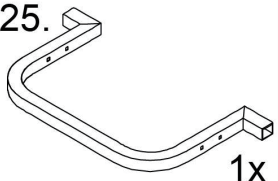



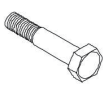

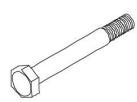

No.	Descripción	Número
1	Montante	2x
2	Viga principal	1x
3	Montante frontal	1x
4	Viga transversal	1x
5	Estabilizador Delantero	1x
6	Barra pivotante	2x
7	Barra transversal	1x
8	Soporte de extensión de pata	1x
9	Brazo móvil	2x
10	Tubo de espuma	2x
11	Tubo de espuma	3x
12	Bloqueo fijado	2x
13	Bloqueo de resorte	3x
14	Asiento	1x
15	Respaldo	1x
16	Tapa final	5x
17	Tapa final	4x
18	Tapa final	10x
19	Tapa final	8x
20	Tapa final	7x

21	Tapa de proteccion	2x
22	Tapa de proteccion	1x
24	Espuma	8x
25	“U” Estabilizador trasero	1x
26	Perilla	2x
27	Perilla	2x
28	Tornillo 8 x 50 mm	8x
29	Tornillo 10 x 60 mm	2x
30	Tornillo 10 x 60 mm	1x
32	Tornillo 8 x 40 mm	4x
33	Tornillo 8 x 20 mm	4x
34	Tornillo 10 x 120 mm	2x
35	Tornillo 8 x 45 mm	2x
36	Arandela 8 x 16 x 1,5 mm	19x
37	Arandela 10 x 20 x 2 mm	5x
38	Perilla	2x
39	Arandela 6 x 16 x 1 mm	2 x
40	Tuerca M10	1x
41	Tuerca M8	11x
42	Tuerca M6	2x
43	Tapa de proteccion	2x
44	Tornillo 8 x 55 mm	3x

DIBUJO DE PIEZAS



12.  2x	13.  3x	14.  1x	15.  1x
16.  Pre-ensamblado 5x	17.  Pre-ensamblado 4x	18.  Pre-ensamblado 10x	19.  Pre-ensamblado 8x
20.  Pre-ensamblado 7x	21.  Pre-ensamblado 2x	22.  Pre-ensamblado 1x	
24.  8x	25.  1x	26.  2x	27.  2x
28.  M8x50 9x	29.  M10x60 2x	30.  M10x60 1x	32.  M8x40 4x
33.  M8x20 4x	34.  M10x120 2x	35.  M8x45 2x	36.  M8 19x
37.  M10 5x	38.  2x	39.  M6 2x	40.  M10 1x
41.  M8 11x	42.  M6 2x	43.  2x	44.  M8x55 3x

MONTAJE

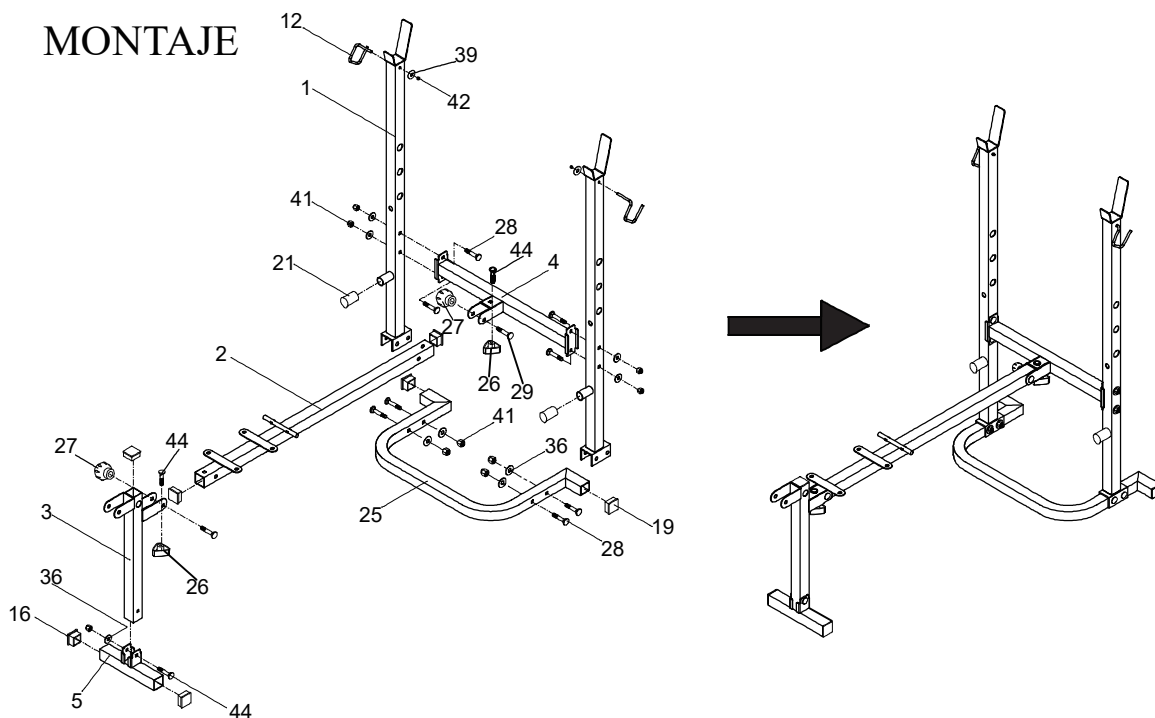

PASO 1

Fije los dos montantes (1) al estabilizador trasero en "U" (25) con 4 juegos de tornillo (28), arandela (36) y tuerca (41), conecte la viga transversal (4) a los dos montantes (1) con 4 juegos de tornillo (28), arandela (36) y tuerca (41), conecte la viga principal (2) al centro de la viga transversal (4) con un juego de tornillo (29), perilla (27) y un juego de tornillos (44), perilla (26). Luego fije el montante frontal (3) al estabilizador delantero (5) con un juego de tornillo (44), arandela (36) y tuerca (41), y conecte el montante frontal (3) a la viga principal (2) con un juego de tornillos (29), perilla (27) y un juego de tornillos (44), perilla (26).

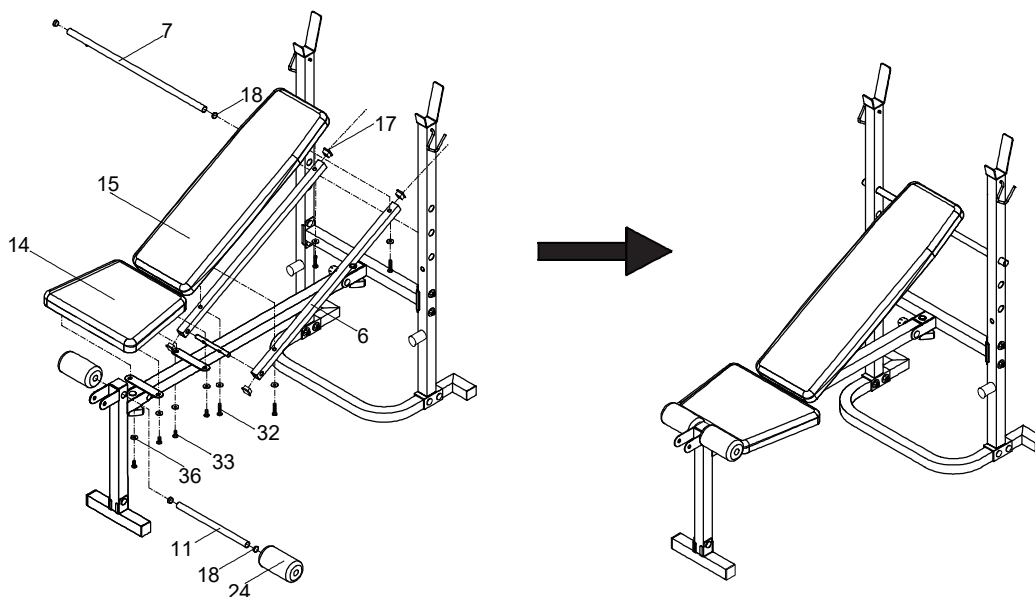

PASO 2

Inserte la barra transversal (7) en el orificio de los dos montantes (1), fije la barra pivotante (6) a la viga principal (2), fije el respaldo (15) en la barra pivotante (6) con 4 juegos de tornillo (32) y arandela (36), luego fije el asiento (14) en la viga principal (2) con 4 juegos de tornillo (33) y arandela (36), inserte el tubo de espuma (26) en el montante frontal (3) y fije la espuma (27) al tubo de espuma (26).

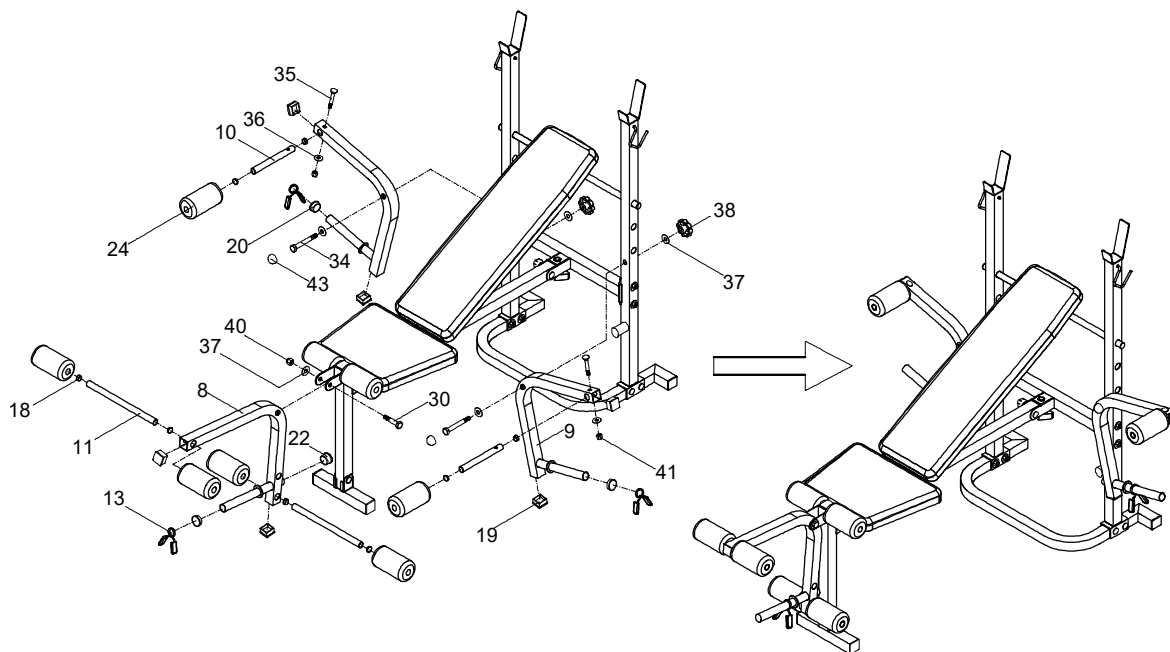

PASO 3

Conecte la espuma (24) al tubo de espuma (10), inserte el tubo de espuma en el brazo móvil (9) con un juego de tornillo (35), arandela (36) y tuerca (41), luego fije los dos brazos móviles en los dos montantes (1) con 2 juegos de tornillo (34), arandela (37) y perilla (38), y fije la tapa protectora (43) en el tornillo (30).

Fije el soporte de extensión de la pata (8) al montante frontal (3) con un juego de tornillo (30), arandela (37) y tuerca (40), inserte los dos tubos de espuma (11) en el soporte de extensión de la pata (8), luego fije la espuma (24) al tubo de espuma (11).

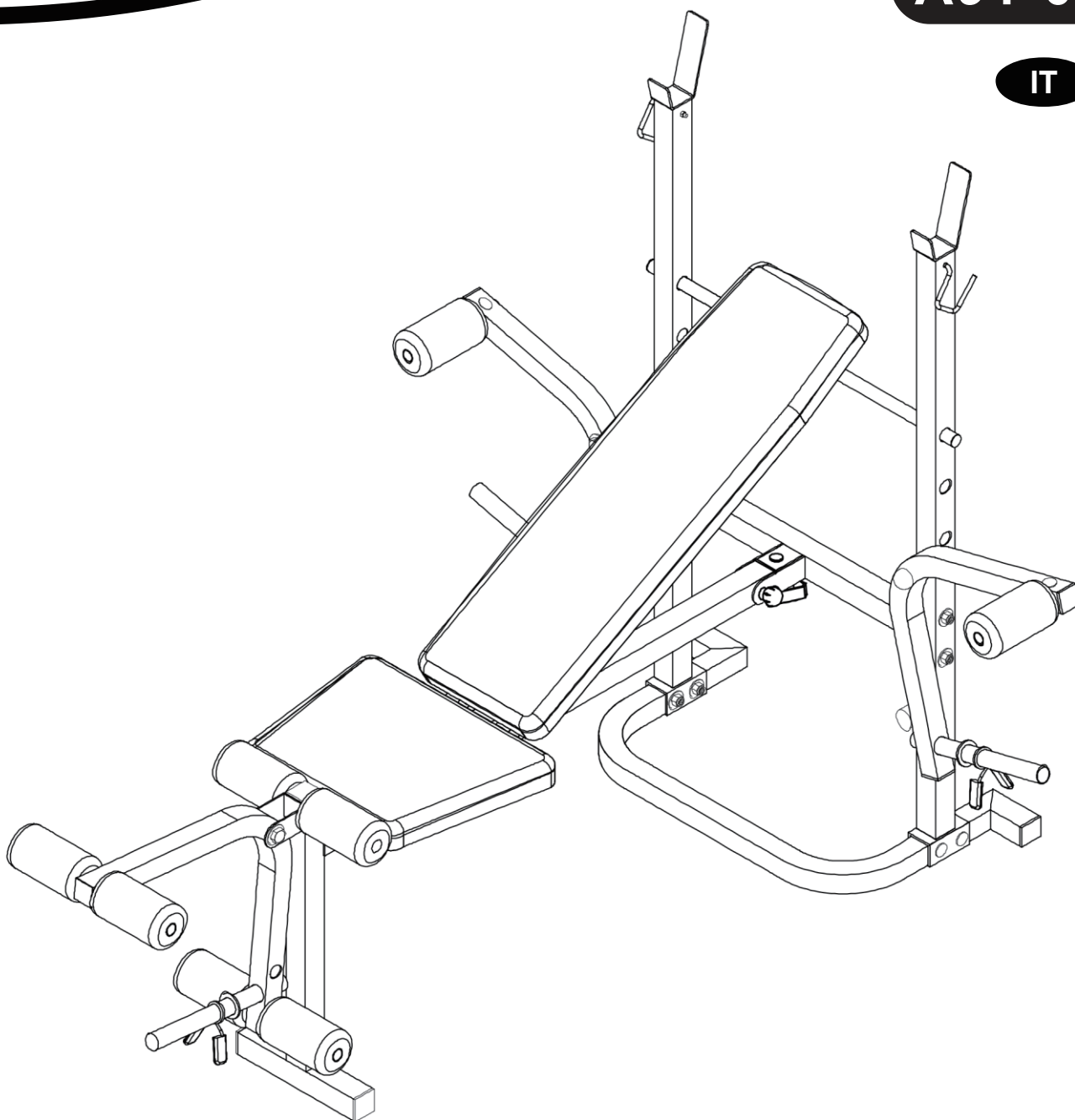

IMPORTANTE - CONSERVARE QUESTE INFORMAZIONI
PER CONSULTARLE IN SEGUITO: LEGGERE ATTENTAMENTE

ISTRUZIONI DI ASSEMBLAGGIO

Lista Parti:

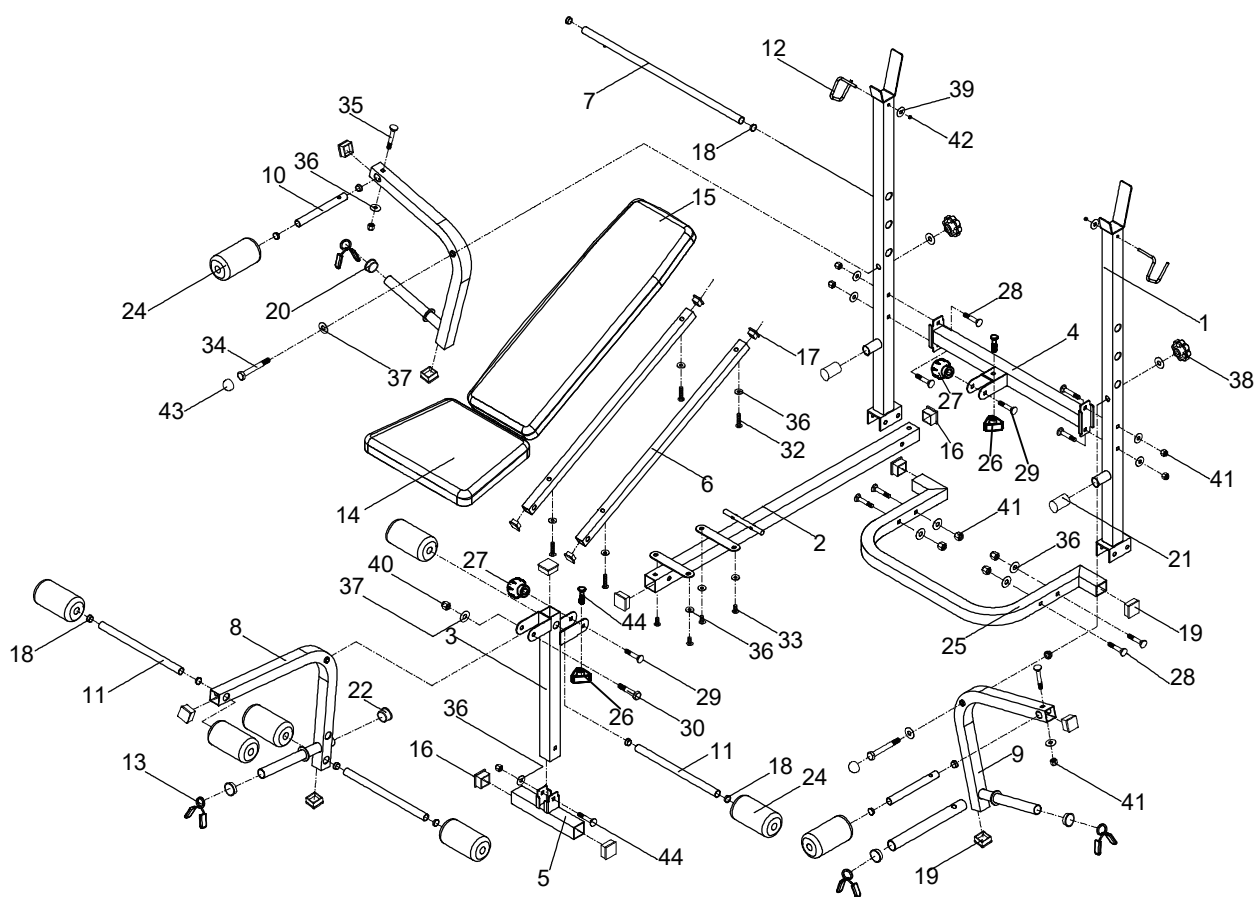







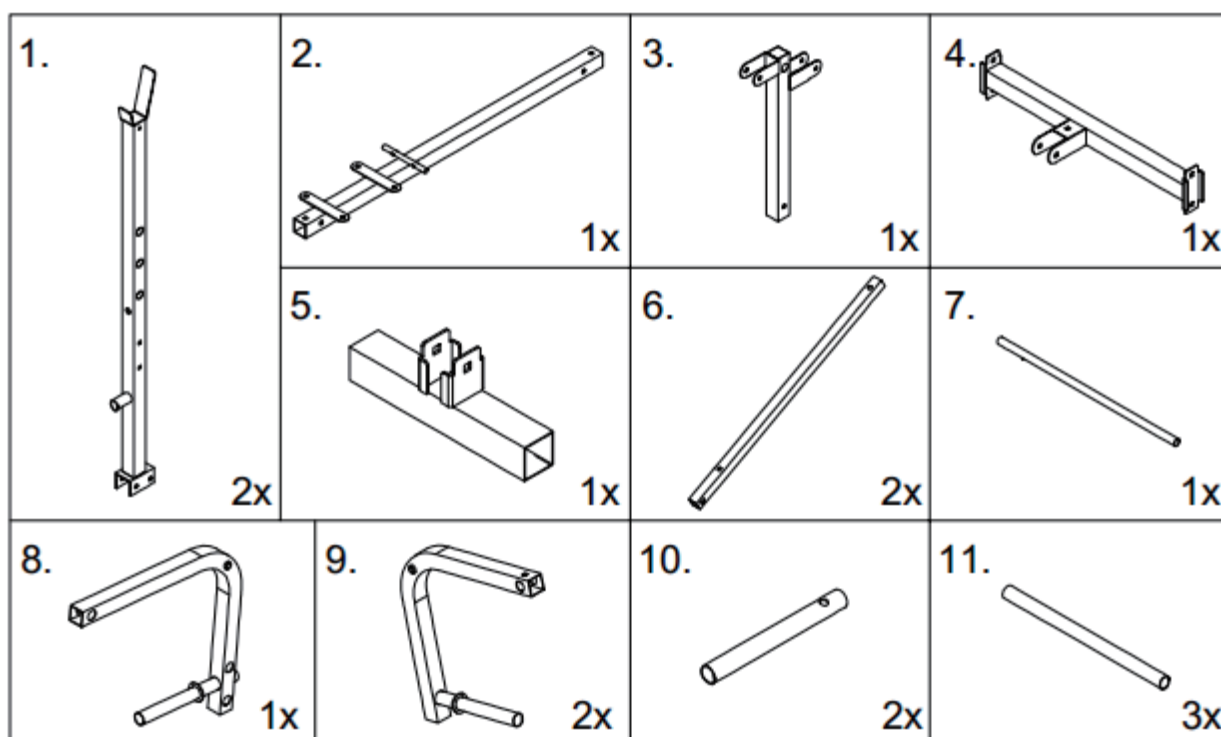



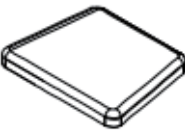
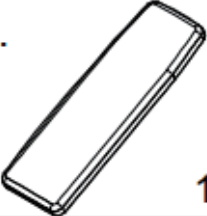







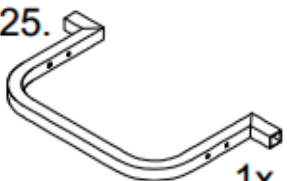









NO.	Descrizione	Numero
1	Montante verticale	2X
2	Montante principale	1X
3	Montante anteriore	1X
4	Traversa	1X
5	Stabilizzatore frontale	1X
6	Barra cardine	2X
7	Traversa	1X
8	Supporto estensione gambe	1X
9	Braccio laterale	2X
10	Tubo in spugna	2X
11	Tubo in spugna	3X
12	Morsetto	2X
13	Morsetto elastico	3X
14	Sedile	1X
15	Schienale	1X
16	Tappo di chiusura	5X
17	Tappo di chiusura	4X
18	Tappo di chiusura	10X
19	Tappo di chiusura	8X

20	Tappo di chiusura	7X
21	Tappo di protezione	2X
22	Tappo di protezione	1X
24	Spugna	8X
25	Stabilizzatore posteriore a "U"	1X
26	Manopola	2X
27	Manopola	2X
28	Vite 8 x 50 mm	8X
29	Vite 10 x 60 mm	2X
30	Vite 10 x 60 mm	1X
32	Vite 8 x 40 mm	4X
33	Vite 8 x 20 mm	4X
34	Vite 10 x 120 mm	2X
35	Vite 8 x 45 mm	2X
36	Rondella 8 x 16 x 1,5 mm	19X
37	Rondella 10 x 20 x 2 mm	5X
38	Manopola	2X
39	Rondella 6 x 16 x 1 mm	2X
40	Dado M10	1X
41	Dado M8	11X
42	Dado M6	2X
43	Tappo di protezione	2X
44	Vite 8 x 55 mm	3X

Illustrazioni delle parti:



12.  2x	13.  3x	14.  1x	15.  1x
16.  Pre-assemblato 5X	17.  Pre-assemblato 4X	18.  Pre-assemblato 10X	19.  Pre-assemblato 8X
20.  Pre-assemblato 7X	21.  Pre-assemblato 2X	22.  Pre-assemblato 1X	
24.  8x	25.  1x	26.  2x	27.  2x
28.  M8x50 9x	29.  M10x60 2x	30.  M10x60 1x	32.  M8x40 4x
33.  M8x20 4x	34.  M10x120 2x	35.  M8x45 2x	36.  M8 19x
37.  M10 5x	38.  2x	39.  M6 2x	40.  M10 1x
41.  M8 11x	42.  M6 2x	43.  2x	44.  M8x55 3x

Assemblaggio:

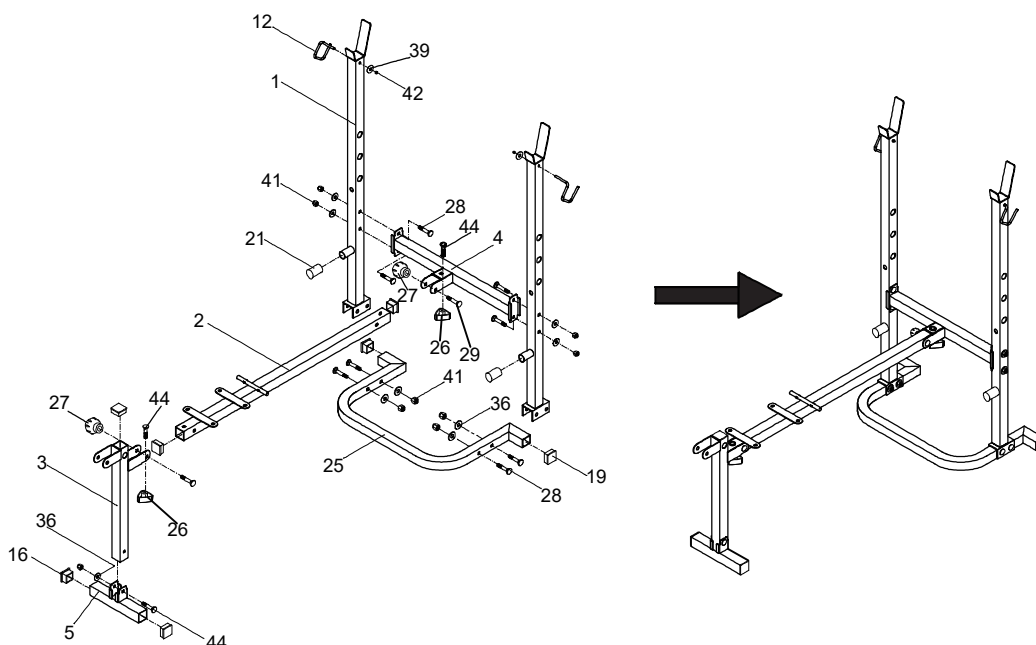

PASSO 1

Fissare i due montanti (1) allo stabilizzatore posteriore a "U" (25) utilizzando 4 set con vite (28), rondella (36) e dado (41), collegare la traversa (4) ai due montanti (1) utilizzando 4 serie di viti (28), rondelle (36) e dadi (41), fissare il montante principale (2) al centro della traversa (4) utilizzando un set con vite (29), manopola (27) e un set con vite (44), manopola (26).

Poi fissare il montante anteriore (3) allo stabilizzatore anteriore (5) utilizzando un set con vite (44), rondella (36) e dado (41), e collegare il montante anteriore (3) alla manopola del montante principale (2) (27) e un set con vite (44), manopola (26), utilizzando un set di viti (29).

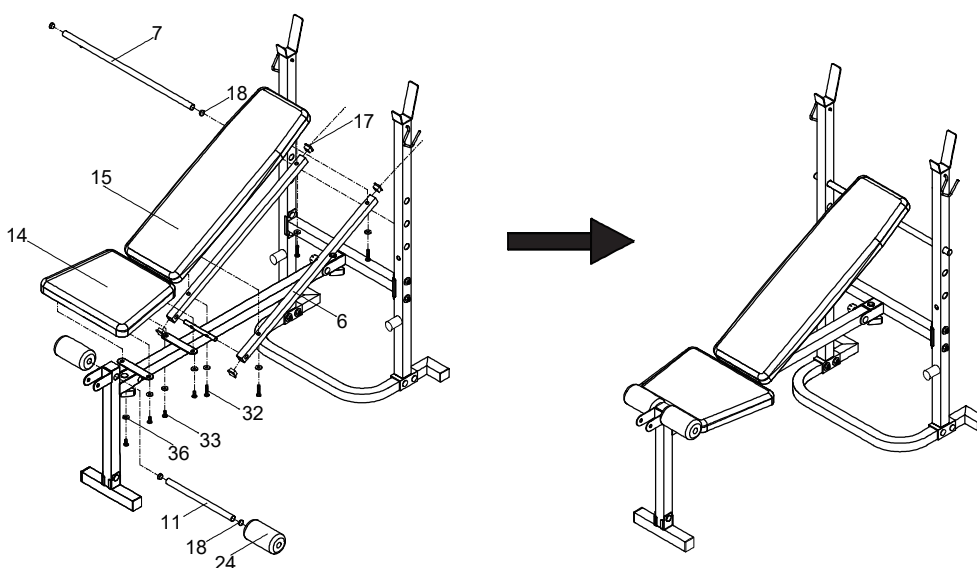

PASSO 2

Inserire la traversa (7) nel foro dei due montanti (1), fissarla (6) al montante principale (2), fissare lo schienale (15) sulla barra cardine (6) utilizzando 4 set con vite (32) e rondella (36), infine fissare il sedile (14) sul montante (2) utilizzando 4 set con viti (33) e rondella (36), inserire il tubo di spugna (26) nella parte anteriore in posizione verticale (3) e fissare la spugna (27) al tubo di spugna (26).

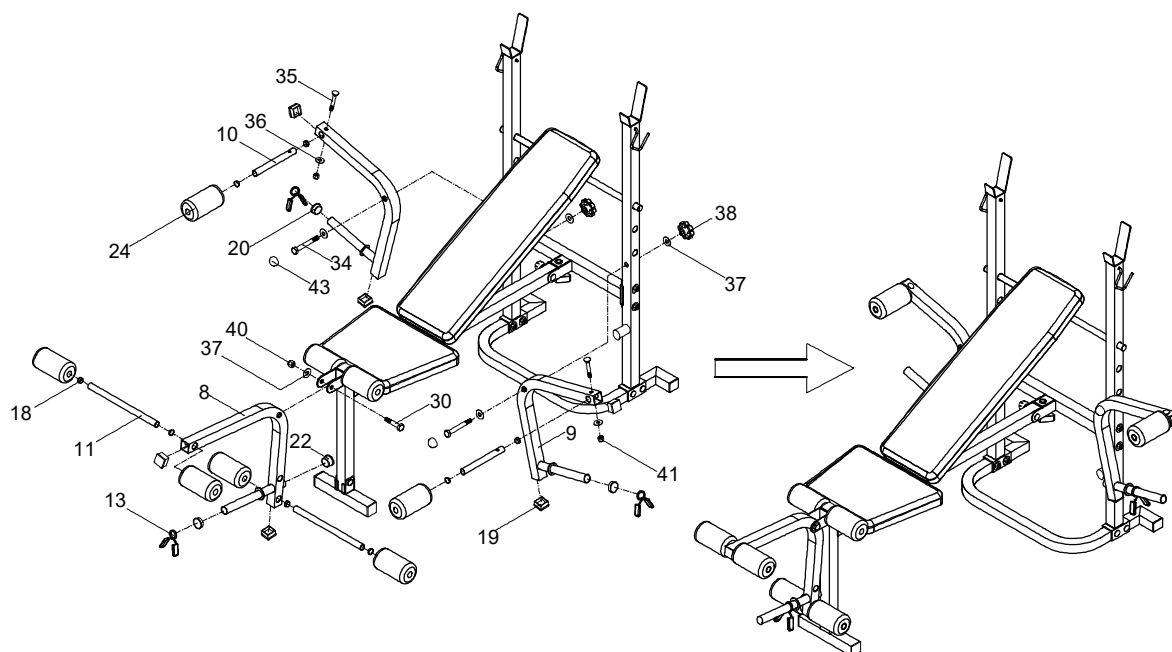

PASSO 3

Fissare la spugna (24) al tubo di spugna (10), inserirlo per l'uso sul braccio (9) con un set di viti (35), rondella (36) e dado (41), quindi fissare i due bracci mobili ai due montanti (1) utilizzando 2 set di viti (34), rondelle (37) e manopole (38) e fissare il tappo di protezione (43) sulla vite (30).

Fissare il supporto di estensione delle gambe (8) al montante anteriore (3) utilizzando un set con vite (30), rondella (37) e dado (40), poi inserire i due tubi di spugna (11) nel supporto di estensione delle gambe (8), infine fissare la spugna (24) al tubo di spugna (11).

UK

If you have any questions, please contact our customer care center.

Our contact details are below:



0044-800-240-4004



enquiries@mhstar.co.uk

IMPORTER ADDRESS:

MH STAR UK LTD

Unit 27, Perivale Park,

Horsenden lane South

Perivale, UB6 7RH

MADE IN CHINA

ES

Si tiene alguna pregunta, comuníquese con nuestro Centro de Atención al Cliente. Nuestros datos de contacto son los siguientes:



0034-931294512



atencioncliente@aosom.es

IMPORTADOR:

SPANISH AOSOM, S.L.

C/ ROC GROS, N° 15. 08550, ELS HOSTALETS DE

BALENYÀ, SPAIN.

B66295775

WWW.AOSOM.ES

ATENCIONCLIENTE@AOSOM.ES

TEL: 931294512

HECHO EN CHINA

FR

Si vous avez la moindre question, veuillez contacter notre centre d'assistance à la clientèle.

Nos coordonnées sont les suivantes:



0033-1-84166106



aosom@mhfrance.fr

Importé par:

MH France

2, rue Maurice Hartmann

92130 Issy-les-Moulineaux

France

Fabriqué en Chine

PT

Se tiver alguma dúvida, por favor contacte o nosso Centro de Atendimento ao Cliente. Os nossos dados de contacto são os seguintes:



0034-931294512



info@aosom.pt.

IMPORTADOR:

SPANISH AOSOM, S.L

C.ROC GROS N.15, 08550. ELS HOSTALETS DE BALENYÀ

TEL: 931294512 (SEG-SEX DAS 7:30H ÀS 16:30H)

INFO@AOSOM.PT

WWW.AOSOM.PT

DE

Wenn Sie Fragen haben, wenden Sie sich bitte an unser Kundendienstzentrum.

Unsere Kontaktdaten stehen unten:



0049-0(40)-88307530



service@aosom.de

ADRESSE DES IMPORTEURE:

MH Handel GmbH

Wendenstraße 309

D-20537 Hamburg

Germany

IN CHINA HERGESTELLT

IT

In caso di dubbio, si prega di contattare il nostro centro assistenza clienti. I nostri dettagli di contatto sono di seguito:



0039-0249471447



clienti@aosom.it

IMPORTATO DA:

AOSOM Italy srl

Centro Direzionale Milanofiori

Strada 1 Palazzo F1

20057 Assago (MI)

P.I.: 08567220960

FATTO IN CINA