



IN230800374V01_US

370-304V80



IMPORTANT, RETAIN FOR FUTURE REFERENCE: READ CAREFULLY

ASSEMBLY INSTRUCTION



Car Body

① x 1



Handlebar

② x 1



Handlebar fixing device A

③ x 2



Handlebar fixing device B

④ x 1



Front wheel

⑤ x 1



Front guard

⑥ x 1



Mudguard

⑦ x 1



Shock absorber

⑧ x 1

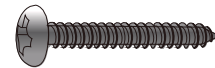

Screw

⑨ x 5



Open spanner

⑩ x 1



L-type Hex wrench

⑪ x 1

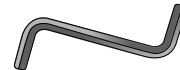

Z-type Hex wrench

⑫ x 1



Hexagonal screw

⑬ x 4

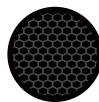

Front guard sticker

⑭ x 1

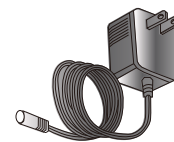

Charger

⑮ x 1



User manual

⑯ x 1

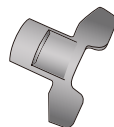

Wrench

⑰ x 2

M8*45

M4*14



9

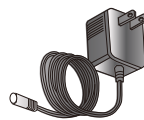

15



16

Tools:

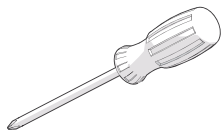

Phillips Screwdriver
(Not Included)



10



11

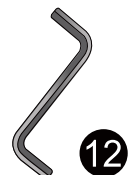

12

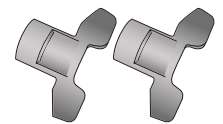

17

Product Specifications:

Battery:	12V 10AH*2
Drive Motor:	24V 350W*1 (2750RPM)
Suitable age:	8-12 years old
Maximum weight:	65kg
Car Size:	119*64*76.5cm
Speed:	8-16km/h
Hours of Use:	Using 0.5 hours after Charging 8-12 hours
Charger:	Input: 100V-240V 50/60Hz Output: 24V 1.0A
Fuse:	Auto-reset fuse

Assembly instruction

Adult assembly is required.

Take care of small parts. To prevent a choking hazard, keep small children away when assembling.

Before assembling, count all small parts carefully, ensuring everything is present. Dispose of the plastic bag properly. Do not let children play with the plastic bag.

1. Shock absorber assembly

Remove the shock absorber ⑧ from the spare parts bag. Loosen the two screws (b) and two nuts (a) using the L-type hex wrench ⑪ and Z-type hex wrench ⑫. Insert the shock absorber ⑧ into the car body, as shown in the provided pictures. Then, tighten the two screws (b) and two nuts (a) using the L-type hex wrench ⑪ and Z-type hex wrench ⑫.

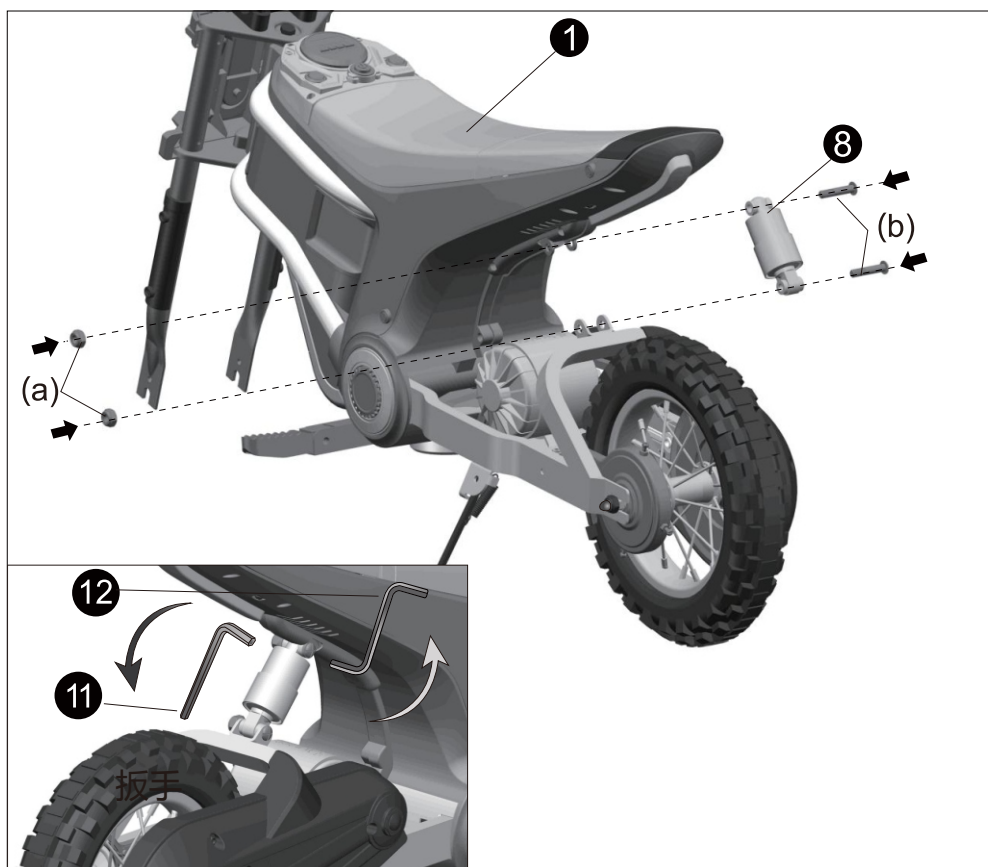

2. Front guard and mudguard assembly

Attach the front guard ⑥ to its correct position on the car body, then fasten it using a 4mm*14mm screw ⑨. Apply the sticker ⑭ onto the front guard ⑥, as shown in the picture.

Insert the mudguard ⑦ into the correct position on the car body, then from the bottom, secure it with four 4mm*14mm screws ⑨ using a screwdriver.

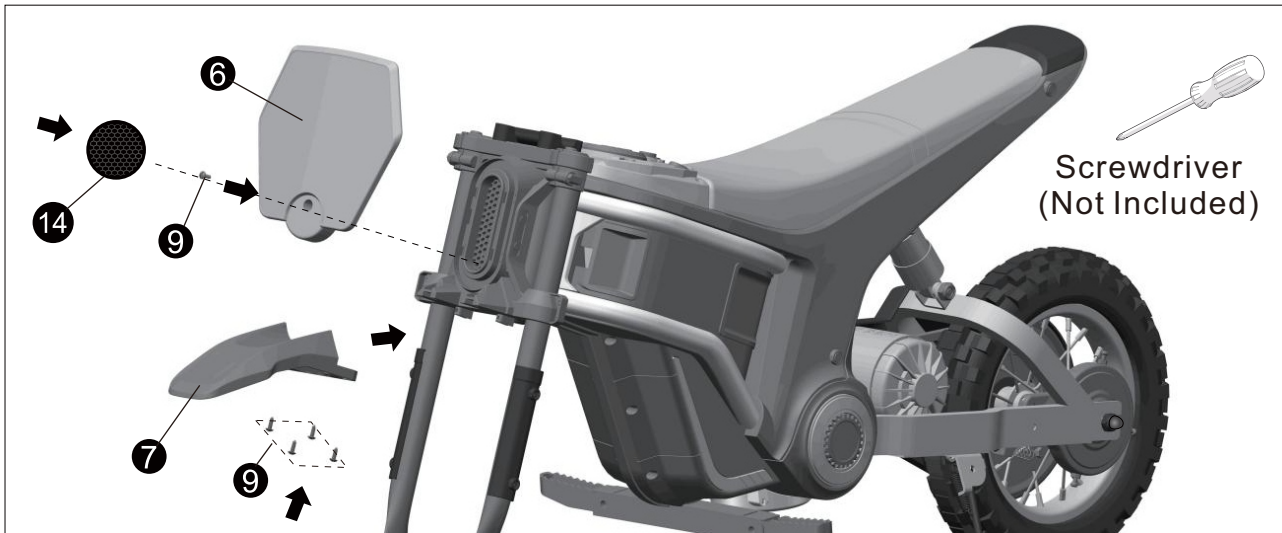

3. Front wheel assembly

Using the wrench ⑱, remove the front axle (A). You will not need the front axle (A) for the next assembly steps.

Loosen the two nuts (C) from the front wheel ④ using the open spanner ⑩, then remove the two washers (B).

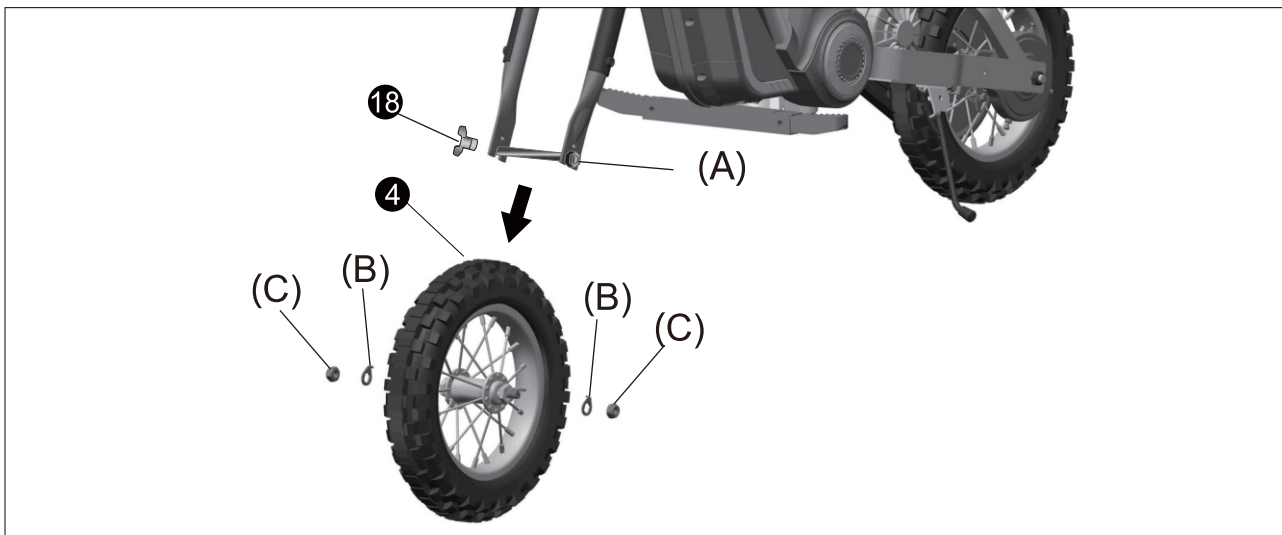

Place the front wheel ④ into the front fork, as shown in the picture. Insert two washers (B) on each side, then secure the front wheel by tightening two nuts (C) using the open spanner ⑩.

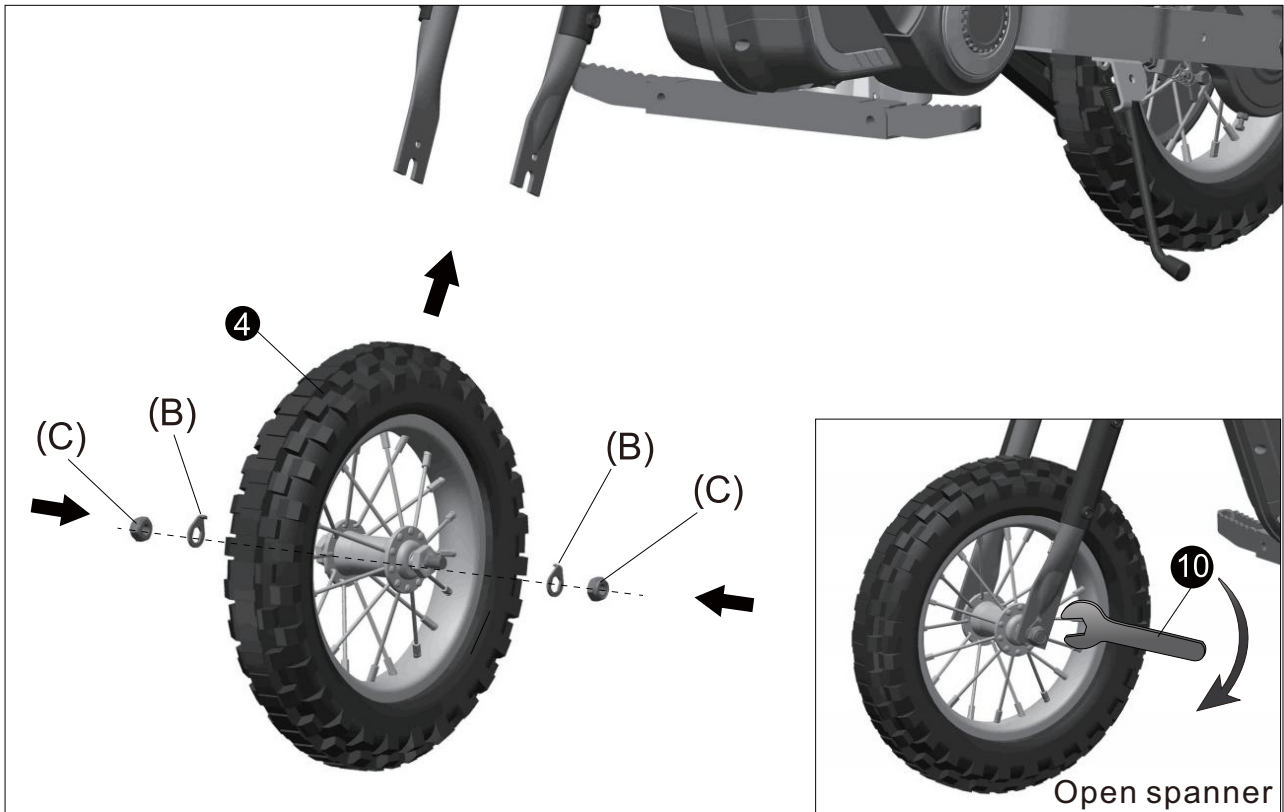

4. Handlebar assembly

Position the handlebar fixing device B ④ over the four holes on the car body. Insert the handlebar ② into place. Attach handlebar fixing device A ③ and insert four 8mm*45mm screws ⑬. Tighten them using the Z-type hex wrench ⑫.

To complete the connection, connect the two plugs from the car body and the handlebar ②.

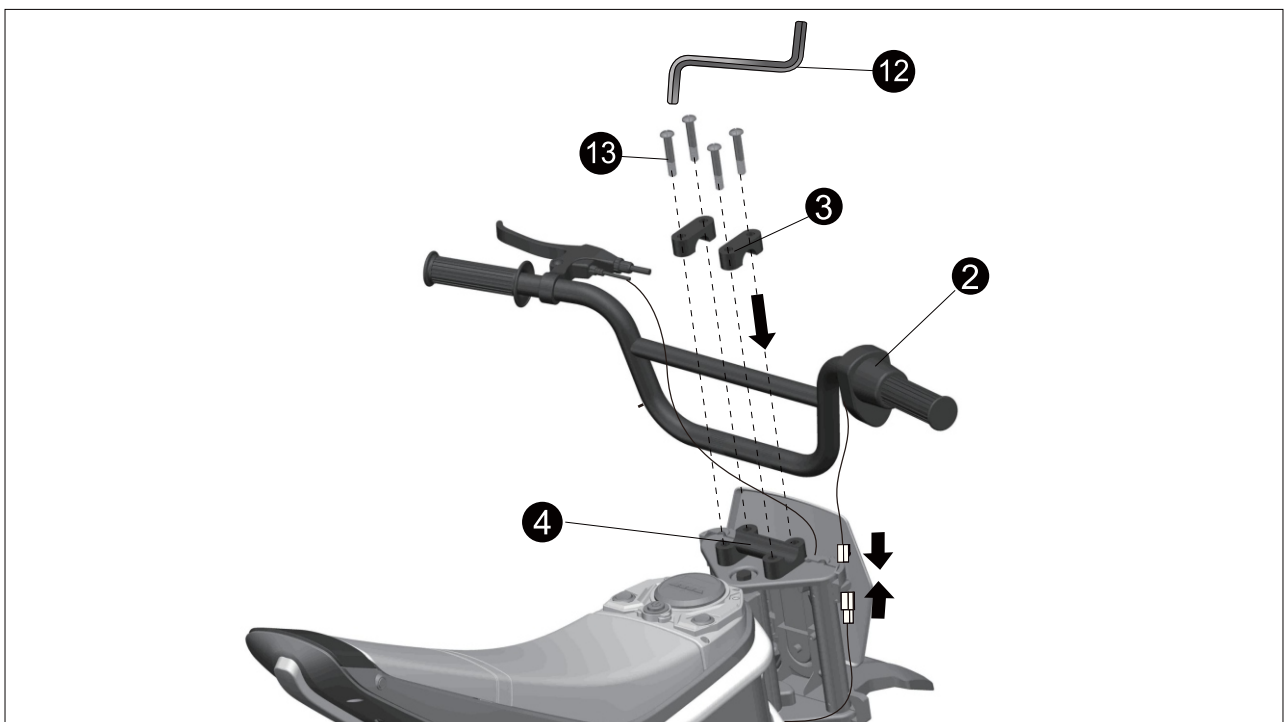

5. Battery connection

Using the screwdriver, loosen and remove the screws (g) from the bottom. Open the seat and connect the power by matching the two red plugs. Using the screwdriver, reattach the seat with two screws (g).

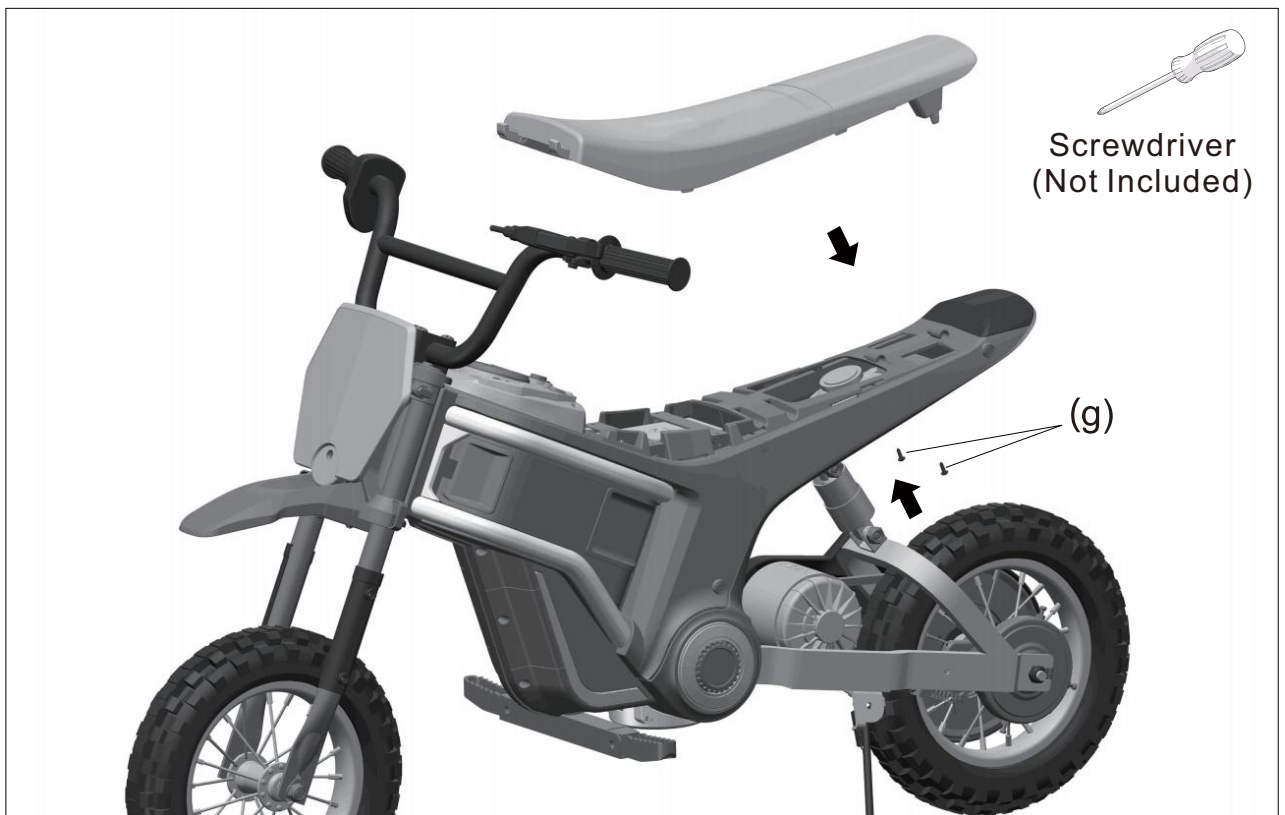
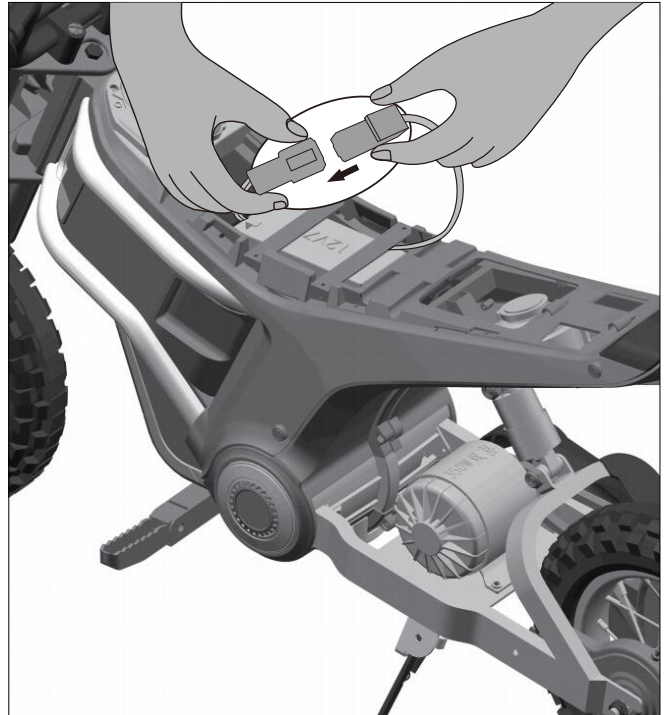
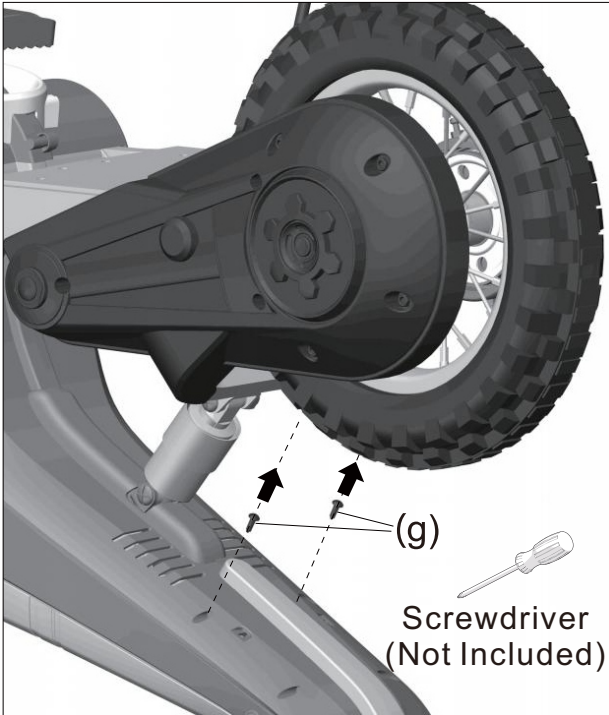

6.Chain adjustment method

If the chain is too loose:

- Using the open spanner ⑩, turn the big nuts anticlockwise on both sides to loosen them.
- Turn the small nuts clockwise on both sides to tighten them.
- Check the chain tension by lightly touching it; it should not be too loose or too tight.
- Once adjusted, using the open spanner ⑩, turn the big nuts clockwise on both sides to tighten them.

If the chain is too tight:

- Using the open spanner ⑩, turn the big nuts anticlockwise on both sides to loosen them.
- Turn the small nuts anticlockwise on both sides to loosen them.
- Check the chain tension by lightly touching it; it should not be too loose or too tight.
- Once adjusted, using the open spanner ⑩, turn the big nuts clockwise on both sides to tighten them.

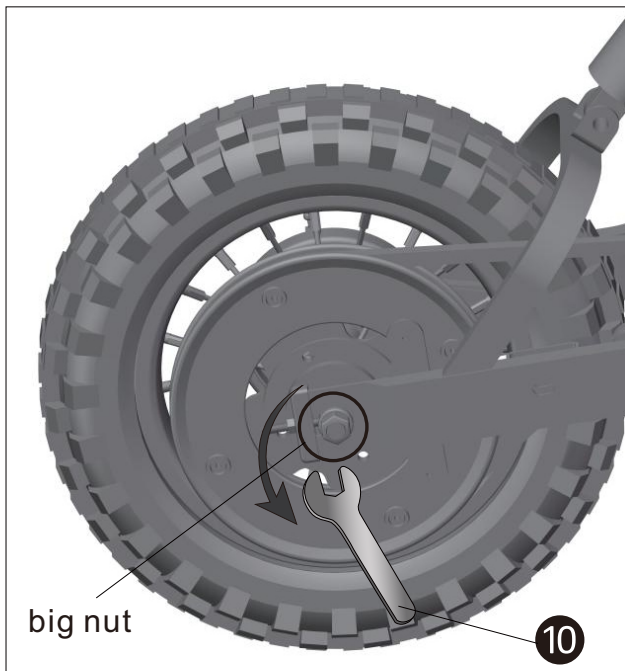

7. Brake adjustment method

(1) Adjusting the brake lever:

- If there is too much travel on the brake, it requires tightening.
- Loosen the white nut (d) on the brake lever by turning it anticlockwise, which tightens the brake.

(2) Adjusting the brake disk nut:

- If the brake still has excessive travel after the lever adjustment, you should focus on the nut (e) near the brake disk.
- Loosen the nut (e) by turning it anticlockwise, which tightens the brake.

(3) Adjusting the brake cable:

- If even after the above adjustments, the brake still has too much travel, you need to check the nut of the brake cable (f).
- Turn the nut of the brake cable (f) anticlockwise to loosen it.
- Tighten the brake cable while holding it in place. Rotate the wheel to assess the level of tightness.
- When you start to feel a slight friction on the wheel, turn the nut of the brake cable (f) clockwise to tighten it.

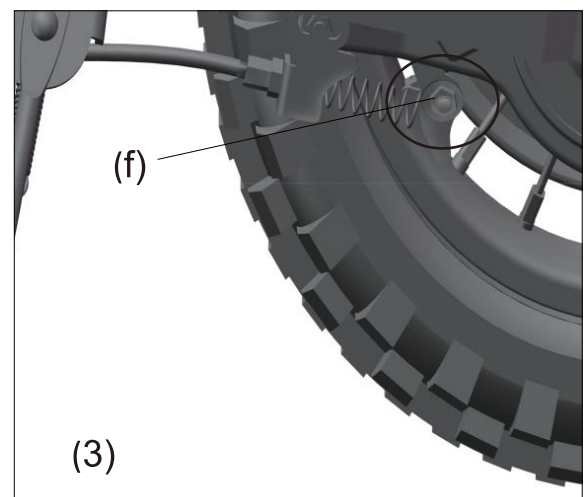
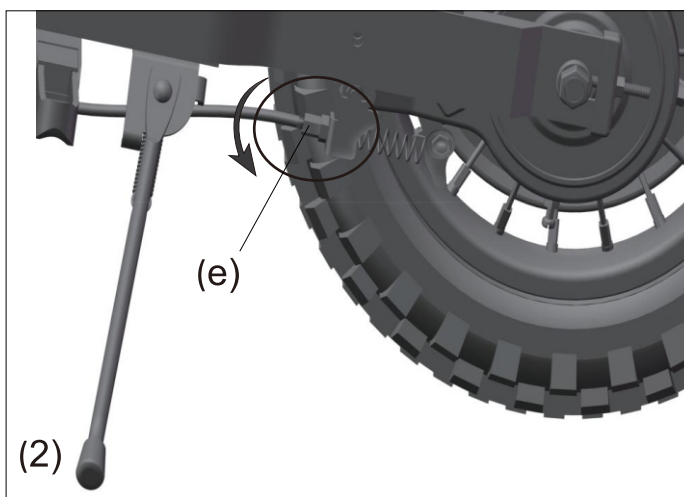
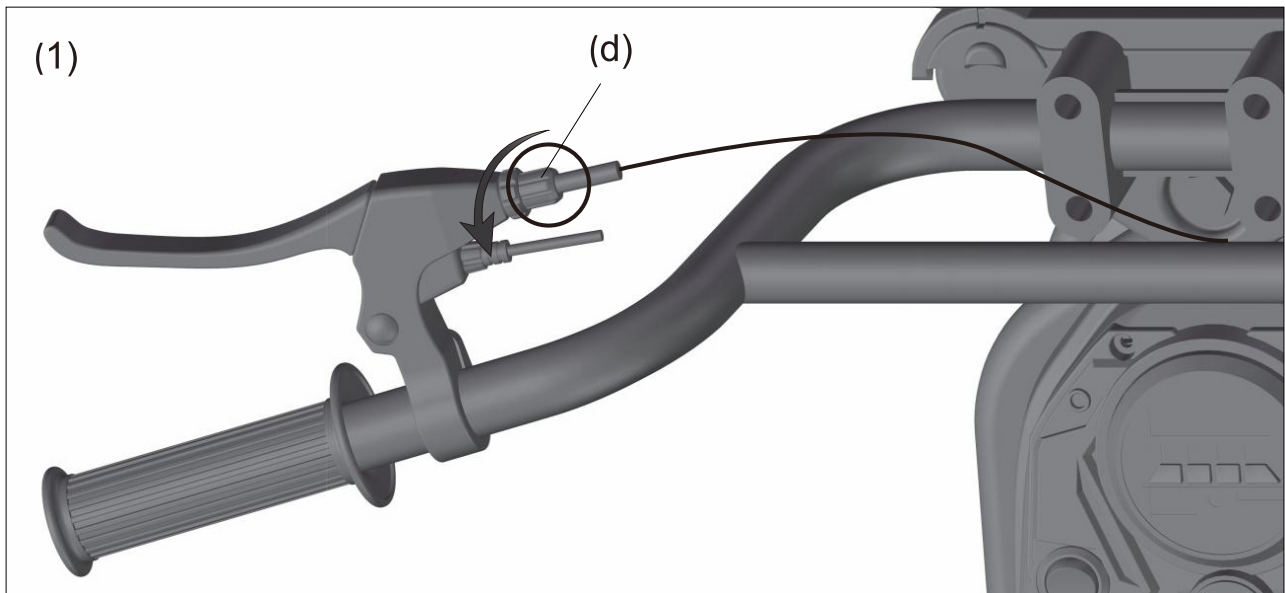

FUSE

The car has an auto-reset fuse. If the car suddenly stops while driving, it is usually due to a sudden surge in current. This causes the fuse to trip automatically.

Turn off the ride-on and do not use for eight seconds, so the fuse can reset. Then, turn on the power again. To avoid the fuse tripping and cutting off the power supply, follow these instructions:

- Do not drag anything behind the ride-on.
- Keep batteries and other electrical components away from water and other liquids.
- Do not alter the circuit system or the structure of the product.

WARNINGS

- Adult assembly is required.
- When unassembled, this product contains small and sharp parts – keep out of the reach of small children.
- Do not use in traffic.
- The seatbelt must be worn when using this product.
- Adult supervision is required when using this product.
- Battery must be charged by an adult. Charge the product before its first use.
- To avoid suffocation, keep packaging out of the reach of children.
- Only use parts provided by the manufacturer.
- Ensure children do not play with the charger.

Note

- Do not use in congested streets, roads, slopes or near drains.
- Do not change the circuit or add electrical devices to the product.
- Keep the car away from water and other liquids to avoid damage.
- The maximum load is 65kg – this product can be used by one child at a time.
- Ensure the power is switched off when not in use. Remove the battery connector when it has not been used for a while.
- Before using and charging, check the plug and other parts for any damage.

Operating(function reference diagram)

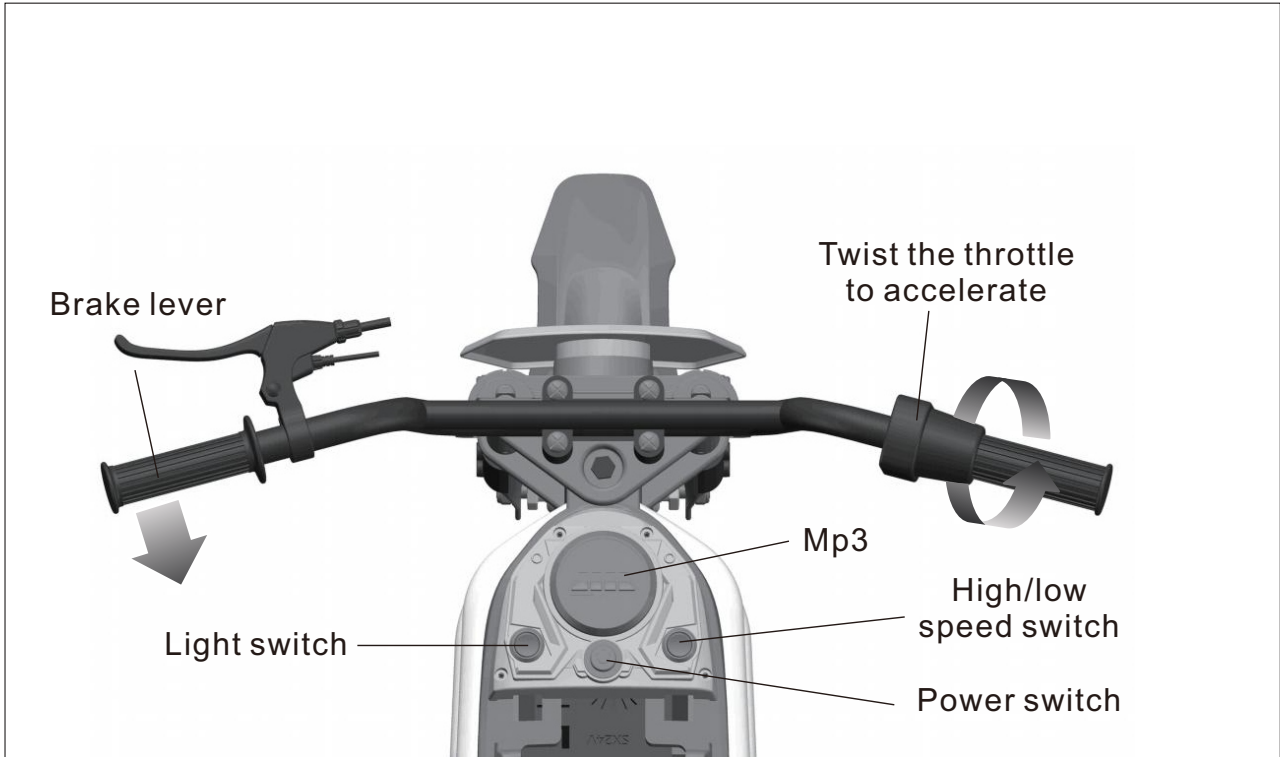

Mp3(optional)

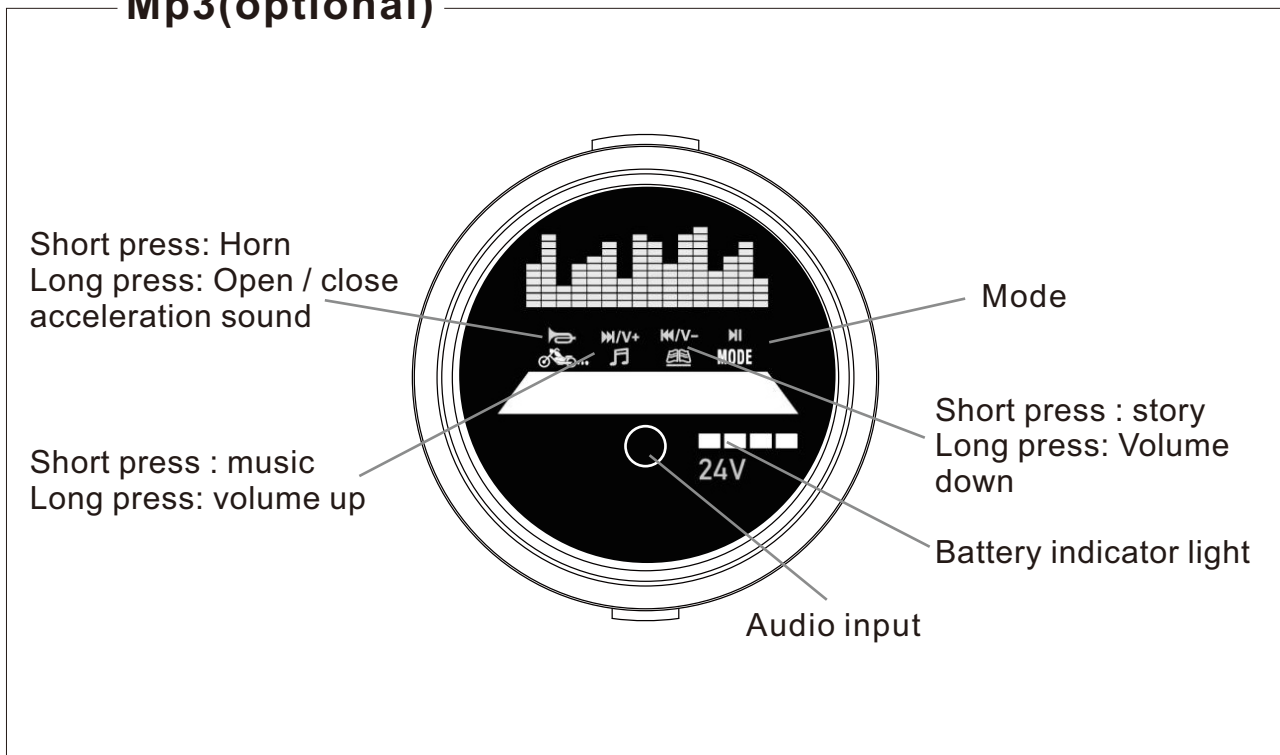

Charging:

- Charge the battery for less than 12 hours – charging for longer can cause permanent damage.
- Place the DC plug into the power socket, then put the charger into the plug. Never use the product while charging.
- This product can be used for one hour – the charging time is 8-12 hours.
- It is normal for the charger and battery to stay cool when charging.
- Do not use the connector near water to avoid damage.
- Only use the supplied charger. Using a charger, which is not supplied by the manufacturer, can damage the product.
- When not in use for a long time, charge the product.

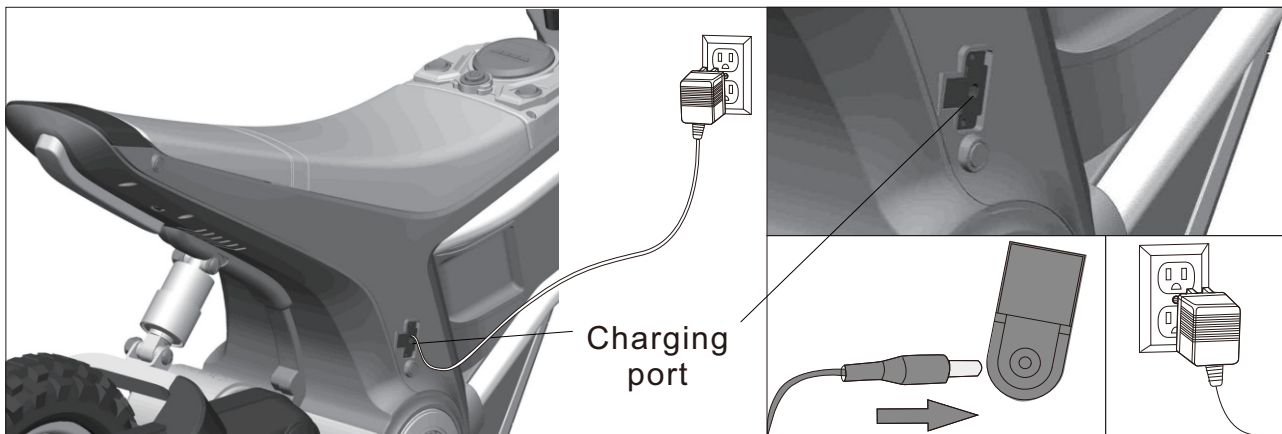

Please follow the instructions to charge the battery.

1. Insert the plug of the charger into the charging port.
2. Insert the charger into the power socket. (The car cannot be started while charging).

Maintenance

- Before using, check the wiring, plug, shell and other parts, ensuring there is no damage.
- When using after a long time, ensure the iron castings are lubricated to avoid rust. When storing, place the product on a flat surface, ensuring it's out of direct sunlight. Keep the product indoors or cover with a water-resistant cloth.
- Keep the product away from stoves, ovens and heaters to avoid plastic from thawing.
- Clean its surface with a dry cloth. Clean plastic parts with non-wax furniture polish.
- Do not clean plastic parts with chemical solutions. Do not clean the car with water.
- Do not drive in wet weather – this could damage the generator, circuit system or battery.
- When not in use, ensure the power is off – the switch should be on 'STOP' or 'OFF'.
- Do not use a fuse that does not conform with the agreed specifications.
- Do not make any modifications to this product or circuit system. Any damages must be fixed by a professional or under the guidance of a professional.

Troubleshooting

Problem	Cause	Solution
The car does not start.	<ul style="list-style-type: none"> - The battery is low. - Failure to press the switch button correctly. - Power connector failure. - Battery breakdown. - Electrical devices are damaged. - Generator is faulty. 	<ul style="list-style-type: none"> - Ensure battery is fully charged. - Follow instructions when using this product. - Reinstall the power connector. - Change battery. - Change electrical devices. - Change generator.
The battery does not charge.	<ul style="list-style-type: none"> - Battery connector failure. - Charger doesn't charge. - Faulty charger. 	<ul style="list-style-type: none"> - Reinstall the connector. - Plug in the charger again. - Change the charger.
The car doesn't drive far.	<ul style="list-style-type: none"> - Battery isn't fully charged. - Overused battery. 	<ul style="list-style-type: none"> - Ensure the battery is fully charged. - Change the battery.
There's a slight noise and the car heats when charging.	<ul style="list-style-type: none"> - This is normal. 	<ul style="list-style-type: none"> - Nothing needs to be done.
The car operates at a slow speed.	<ul style="list-style-type: none"> - Overused battery. - The battery is dead. - The product has exceeded its maximum load. - Uneven driving surface. 	<ul style="list-style-type: none"> - Change the battery. - Ensure battery is fully charged. - Ensure the weight is below 65kg. - Drive on a flat and even surface.

If you have any questions, please contact our customer care center.
Our contact details are below:



001-877-644-9366



customerservice@aosom.com

Imported by Aosom LLC
27150 SW Kinsman Rd Wilsonville, OR 97070 USA
MADE IN CHINA

