

Outsunny

IN230800410V01_GL

344-069V00

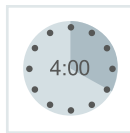
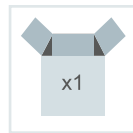

**UK
CA**

CE

EN: **WARNING:** Certification Age: 36+ months; Max weight: 70kg/seat.

DE: **WARNUNG:** Zertifizierungsalter: 36+ Monate; Max. Gewicht: 70kg/Sitz.

FR: **ATTENTION:** Âge de certification: 36+ mois; Poids maximum: 70 kg/siège.

ES: **ADVERTENCIA:** Edad de certificación: 36+ meses; Peso máximo: 70kg/asiento.

IT: **ATTENZIONE:** Età di certificazione: 36+ mesi; Peso massimo: 70 kg/seduta.

EN_IMPORTANT, RETAIN FOR FUTURE REFERENCE: READ CAREFULLY.

FR_IMPORTANT: A LIRE ATTENTIVEMENT ET À CONSERVER POUR CONSULTATION ULTÉRIEURE.

ES_IMPORTANTE, LEA Y GUARDE PARA FUTURAS REFERENCIAS.

DE_WICHTIG! SORGFÄLTIG LESEN UND FÜR SPÄTER NACHSCHLAGEN AUFBEWAHREN.

IT_IMPORTANTE! CONSERVARE IL PRESENTE MANUALE PER FUTURO RIFERIMENTO E LEGGERLO ATTENTAMENTE.

EN

WARNING:

1. CHOKING HAZARD—Small parts. Not for children under 3 years.
2. Only allowed for adults to install, keep children away.
3. To be used under the direct supervision of an adult.
4. Check all the parts are well connected before use.
5. Regularly check and maintain the main components (suspenders, fasteners, fixings, etc.), otherwise the swing may tip over or cause a fall.
6. Installation area should be as wide as possible, flat and avoid dampness.
7. Keep away from fire.

MAINTENANCE

1. Please wipe the surface stains of product with a dry cloth. If necessary, use mild soap or detergent to clean them. After wiping with a soft wet cloth, wipe them with a dry cloth. Do not use a strong acid-alkaline cleaning solution to clean them.
2. If not used for a long time, please put it in a cool and dry place and cover it with clean cloth or blanket.

FR

AVERTISSEMENT :

1. Risque d'étouffement - Présence de petites pièces. Déconseillé aux enfants de moins de 3 ans.
2. Installation par des adultes exclusivement, ne pas laisser les enfants s'approcher.
3. Surveillance permanente par un adulte lors de l'utilisation.
4. Vérifiez que toutes les pièces sont bien connectées avant utilisation.
5. Vérifiez et entretenez régulièrement les principaux composants (suspensions, attaches, fixations, etc.), sinon la balançoire peut basculer ou provoquer une chute.
6. La zone d'installation doit être aussi large que possible, plate et non humide.
7. Tenir à l'écart du feu.

ENTRETIEN

1. Veuillez essuyer les taches de surface sur le produit avec un chiffon sec. Si nécessaire, utilisez un savon doux ou un détergent pour les nettoyer. Après les avoir essuyées avec un chiffon doux et humide, essuyez-les avec un chiffon sec. N'utilisez pas de solution de nettoyage acide ou alcaline forte pour les nettoyer.
2. Si vous ne l'utilisez pas pendant une longue période, rangez-le dans un endroit frais et sec et couvrez-le d'un tissu ou d'une couverture propre.



Adresses sur quefairedemesdechets.fr

WARNUNG:

1. ERSTICKUNGSGEFAHR-Kleinteile. Nicht für Kinder unter 3 Jahren geeignet.
2. Darf nur von Erwachsenen installiert werden, halten Sie Kinder fern.
3. Nur unter der direkten Aufsicht eines Erwachsenen verwenden.
4. Prüfen Sie vor dem Gebrauch, ob alle Teile gut miteinander verbunden sind.
5. Überprüfen und warten Sie regelmäßig die Hauptbauteile (Aufhängungen, Verschlüsse, Befestigungen usw.), sonst kann die Schaukel umkippen oder einen Sturz verursachen.
6. Die Aufstellfläche sollte so breit wie möglich und flach sein und Feuchtigkeit vermeiden.
7. Von Feuer fernhalten.

WARTUNG

1. Bitte wischen Sie die Oberflächenflecken des Produkts mit einem trockenen Tuch ab. Falls erforderlich, verwenden Sie milde Seife oder Reinigungsmittel, um sie zu reinigen. Nach dem Abwischen mit einem weichen, feuchten Tuch, wischen Sie sie mit einem trockenen Tuch ab. Verwenden Sie zum Reinigen keine stark säurehaltige oder alkalische Reinigungslösung.
2. Wenn sie längere Zeit nicht benutzt wird, stellen Sie sie bitte an einen kühlen und trockenen Ort und decken Sie sie mit einem sauberen Tuch oder einer Decke ab.

ADVERTENCIA:

1. PELIGRO DE ASFIXIA: Contiene piezas pequeñas. No es adecuado para los niños menores de 3 años.
2. Sólo puede ser montado e instalado por un adulto, mantenga a los niños alejados del área de instalación.
3. Debe ser utilizado bajo la supervisión directa de un adulto.
4. Compruebe si todas las piezas estén conectadas bien antes de utilizarlo.
5. Inspeccione y realice mantenimiento para los componentes principales regularmente (tirantes, sujetadores, fijaciones, etc.), de lo contrario, el columpio puede volcarse o causar una caída.
6. El área para realizar la instalación debe ser lo más amplia posible, nivelada y puede evitar la humedad.
7. Mantenga el columpio y tobogán infantil alejado del fuego.

MANTENIMIENTO

1. Limpie las manchas en superficie del columpio y tobogán infantil con un paño seco. Si es necesario, utilice un jabón suave o detergente para limpiarlos. Después de limpiarlos con un paño suave húmedo, séquelos con un paño seco. No utilice una solución de limpieza ácido-alcálica fuerte para realizar la limpieza.
2. Si el columpio y tobogán infantil no se utiliza durante mucho tiempo, guárdelo en un lugar fresco y seco y cúbralo con una tela o una manta limpia.

AVVERTENZE:

1. RISCHIO DI SOFFOCAMENTO - Piccole parti. Non adatte a bambini sotto i 3 anni.
2. Consentito solo agli adulti di installare, e tenere lontani I bambini.
3. Viene utilizzato sotto la diretta supervisione di un adulto.
4. Controllare che tutte le parti siano ben collegate prima dell'uso.
5. Controllare e mantenere regolarmente i componenti principali (strutture di sospensione, elementi di fissaggio, fissaggi, ecc.), altrimenti l'oscillazione potrebbe causare il ribaltamento o una caduta.
6. La zona per installazione deve essere il più ampia possibile, piatta ed evitare l'umidità.
7. Tenere lontano dal fuoco.

MANUTENZIONE:

1. Si prega di pulire le macchie superficiali del prodotto con un panno asciutto. Se necessario, utilizzare sapone o detergente morbido per pulirle. Dopo le aver pulito con un panno morbido e umido, pulire con un panno asciutto. Non utilizzare un forte detergente alcalino o acido.
2. Se non viene utilizzato per lungo tempo, conservarlo in un luogo fresco e asciutto, e coprirlo con un pezzo di pulito tessuto o con una coperta.

BOARD LIST

B1 X1 

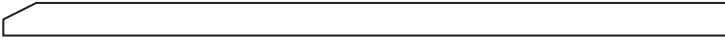
B2 X2 

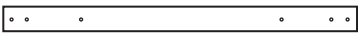
C1 X4 

C2 X4 

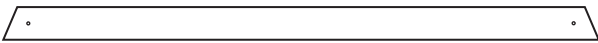
F1 X2 

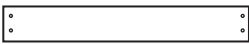
F2 X2 

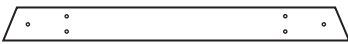
F3 X2 

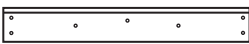
F4 X2 

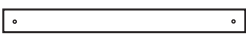
F5 X4 

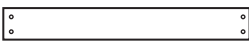
F7 X2 

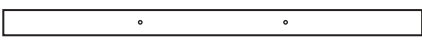
F8 X2 

F9 X2 

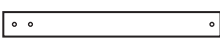
F10 X2 

F11 X2 

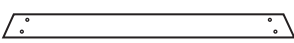
F12 X1 

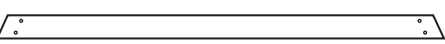
F13 X1 

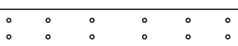
D2 X1 

D3 X1 

H2 X10 

H3 X1 

H4 X1 

H5 X1 

H6 X1 

H7 X1 

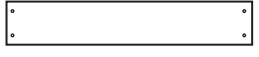
H8 X1 

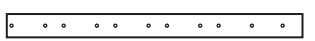



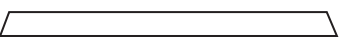

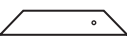



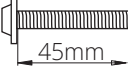

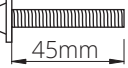
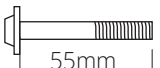
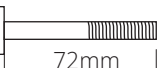
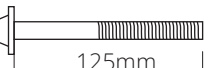













H9 X1 

H57 X6 

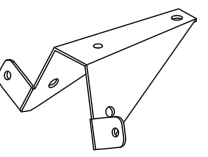
K1 X1 

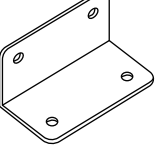
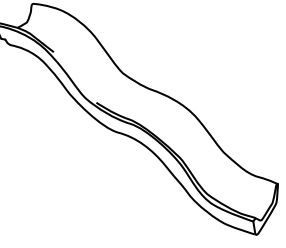
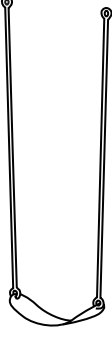
K33 X4 



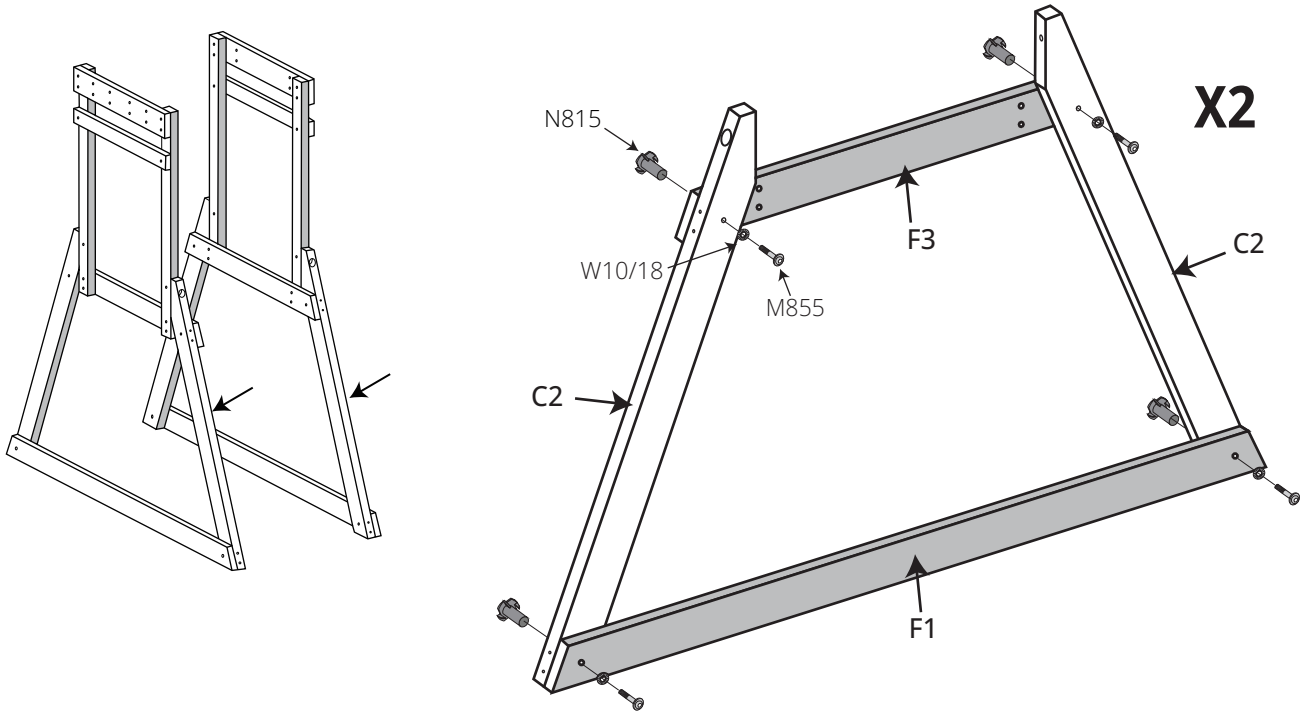

T1 X2 

M645		x12 (+1 spare)	M821		x4	M845		x2
M855		x36 (+2 spare)	M872		x2	M8125		x1
BM818		x8 (+1 spare)	BM825		x1	SW16		x14 (+1 spare)
SW28		x11 (+1 spare)	SW35		x82 (+2 spare)	SW50		x50 (+2 spare)
SW60		x2	M6SW35		x10 (+1 spare)	M6SW55		x24 (+1 spare)
M8SW35		x1	N610		x12 (+1 spare)	N815		x40 (+2 spare)
						AN8		x4
W8/15		x12 (+1 spare)	W10/18		x37 (+2 spare)	W12/28		x4
						H11		x8
						H241		x4
P008		x1	P301		x4	P129		x1
						P015		x2
P712		x1	S110		x2	Star Bit(S)		
						Star Bit(L)		
						Allen Wrench(S)		
						Allen Wrench(L)		

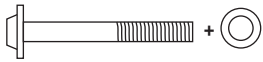
STEP1



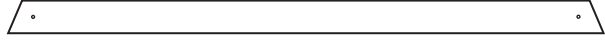

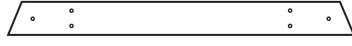

All bolts have to be assembled with washer

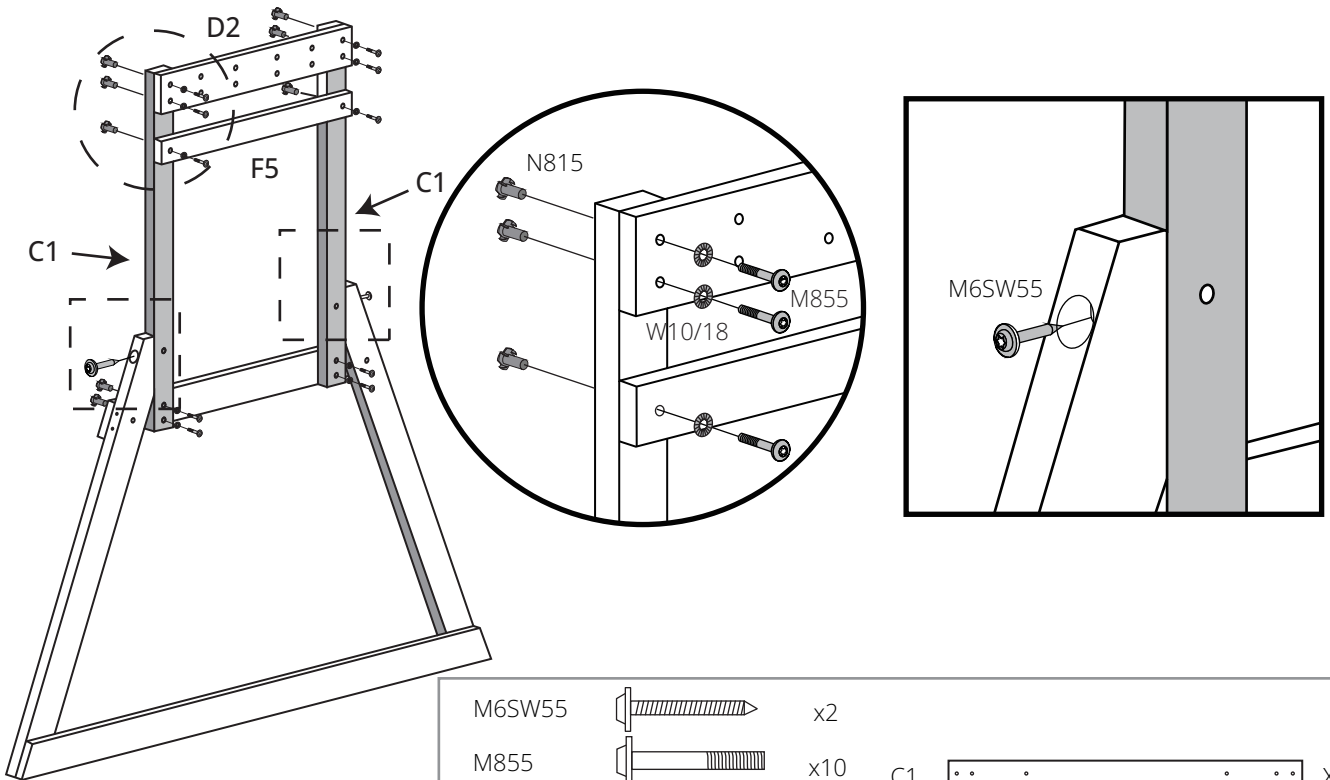
M855		x8	C2		x4
N815		x8	F1		x2
W10/18		x8	F3		x2

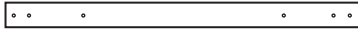
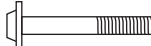
STEP2

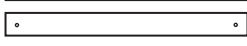

M6SW55		x2	C1		x2
M855		x10	D2		x1
N815		x10	F5		x1
W10/18		x10			

STEP3

M6SW55		x2		
M855		x10	C1	X2
N815		x10	D1	X1
W10/18		x10	F5	X1

STEP4

The top of F4 must be flush with the top of F3

			F2	X1
SW50		x4	F4	X1
M6SW55		x8	F7	X1

STEP5

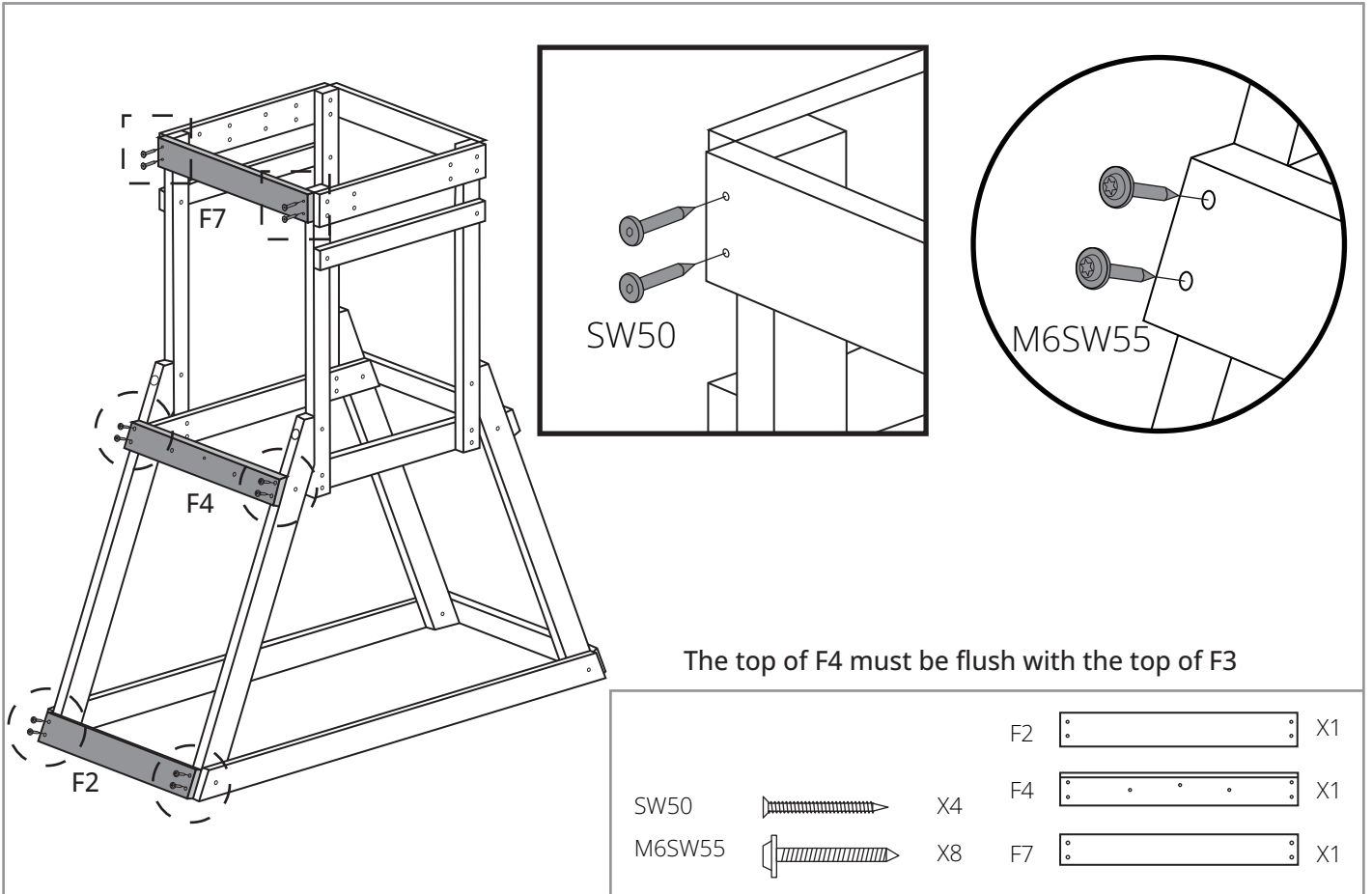

STEP6

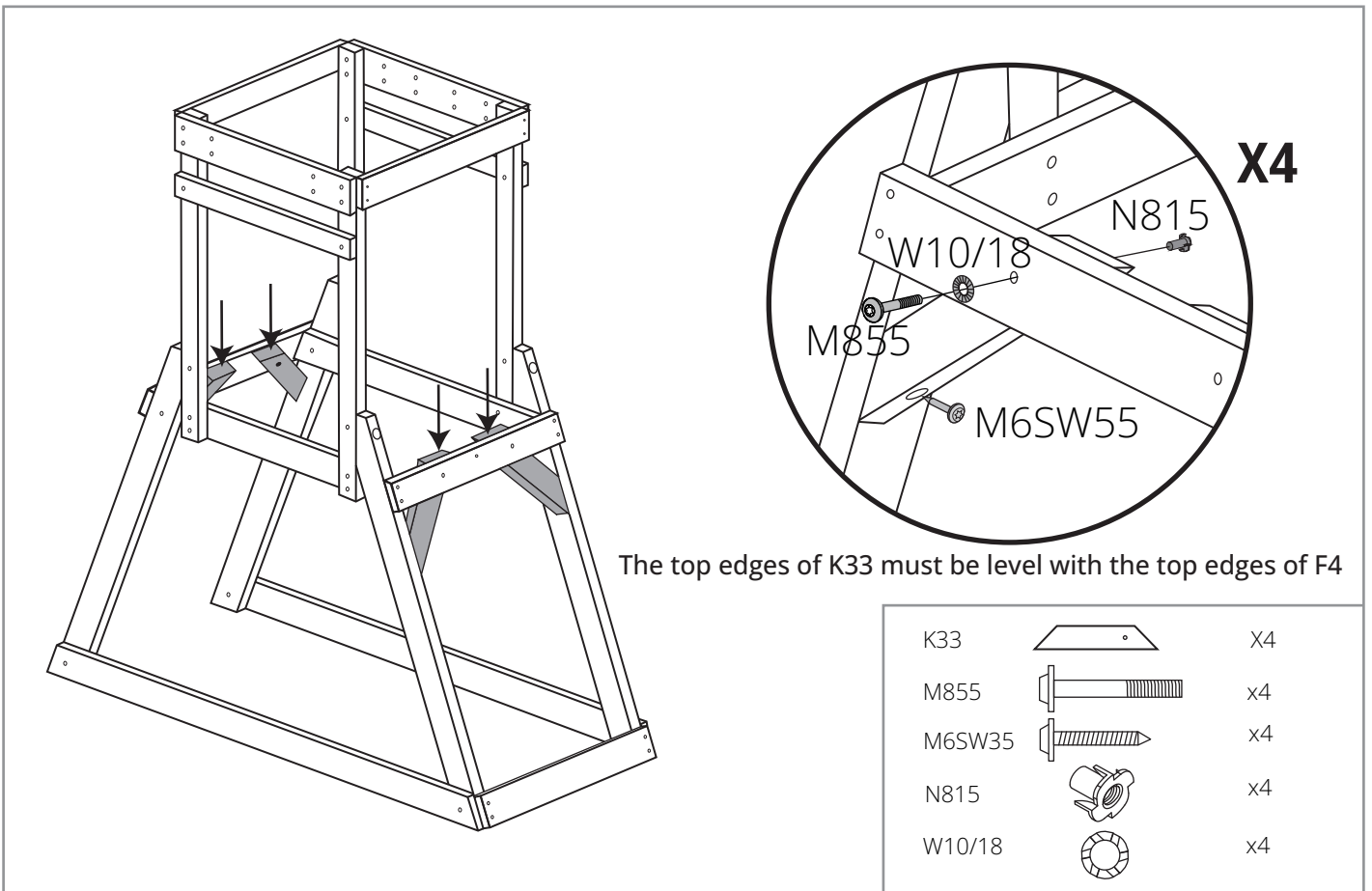

STEP7

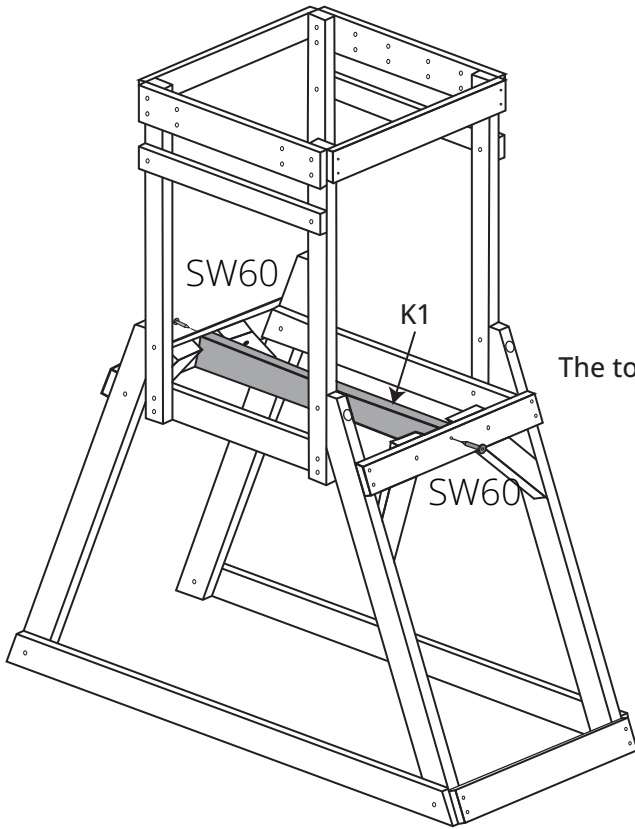

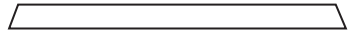

The top edges of K1 must be level with the top edges of F4

SW60		x2
K1		x1

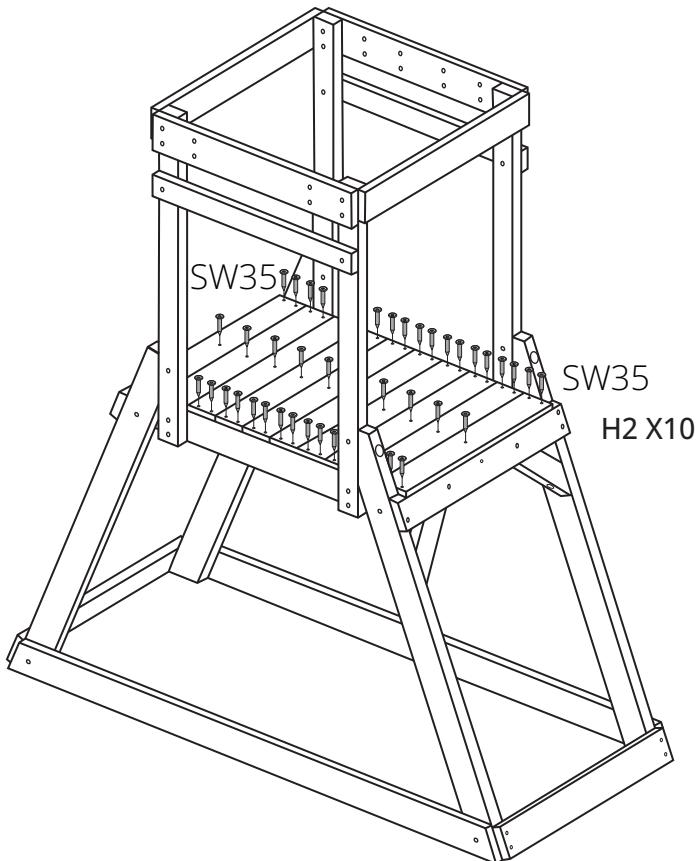
STEP8

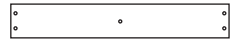

H2		x10
SW35		x50

STEP9

F5

F5

W10/18

M855

N815

X4

W10/18		x4	F5		x2
N815		x4	M855		x4

STEP10

H57 X6

65mm 65mm 65mm 65mm

SW35

X2

H57		x6	SW35		x24
-----	--	----	------	--	-----

STEP11

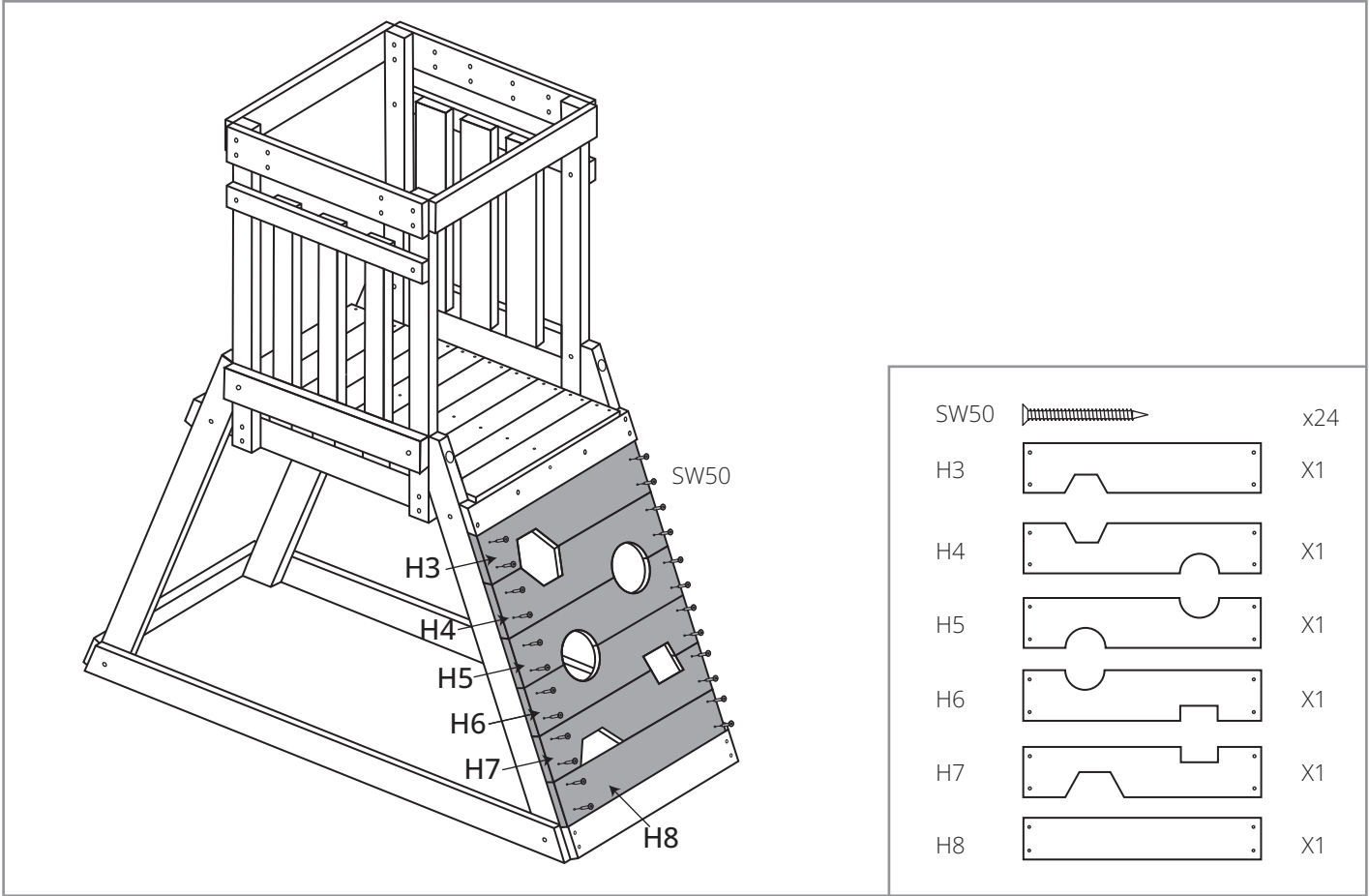

STEP12

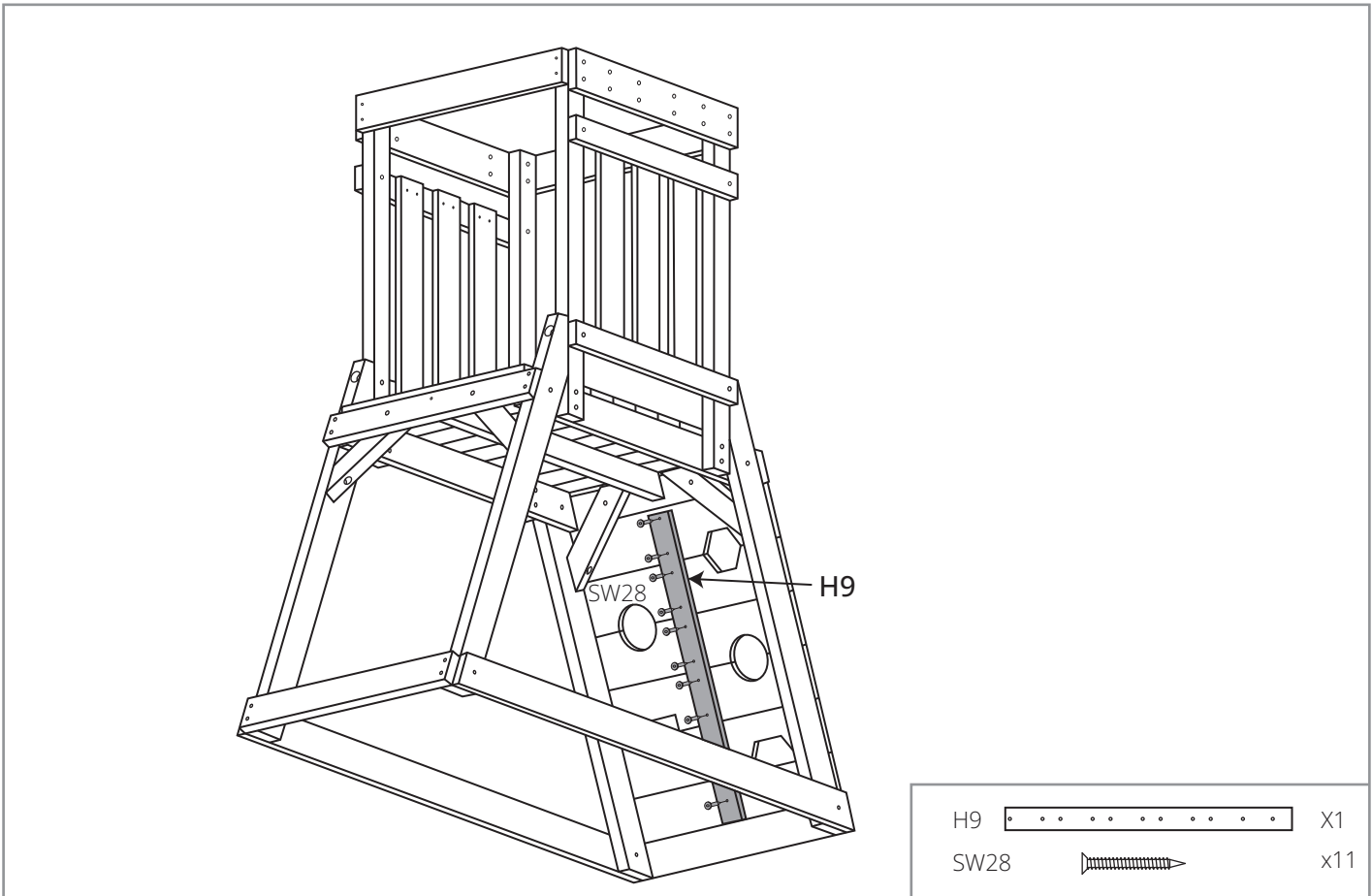

STEP13

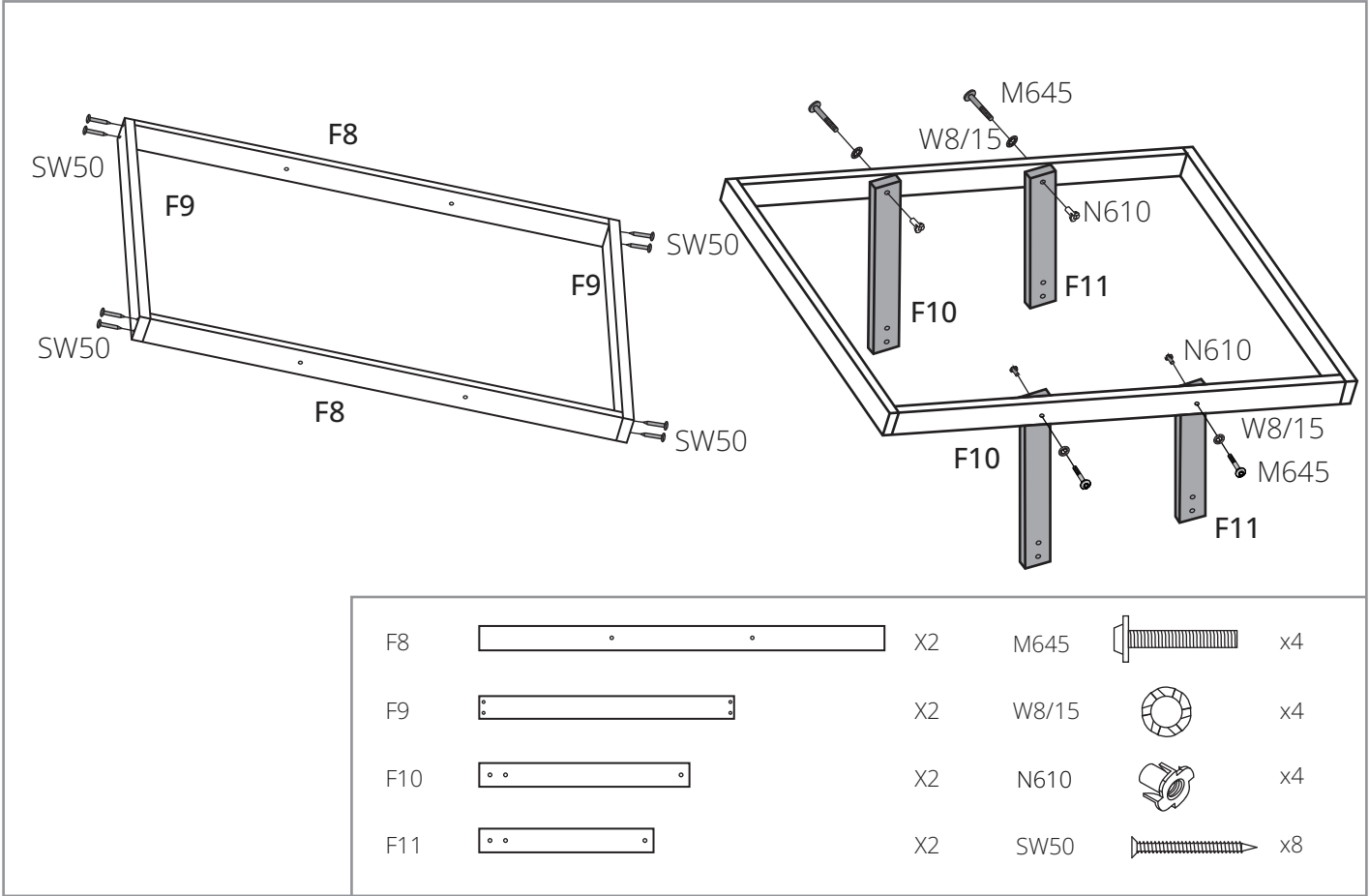

STEP14

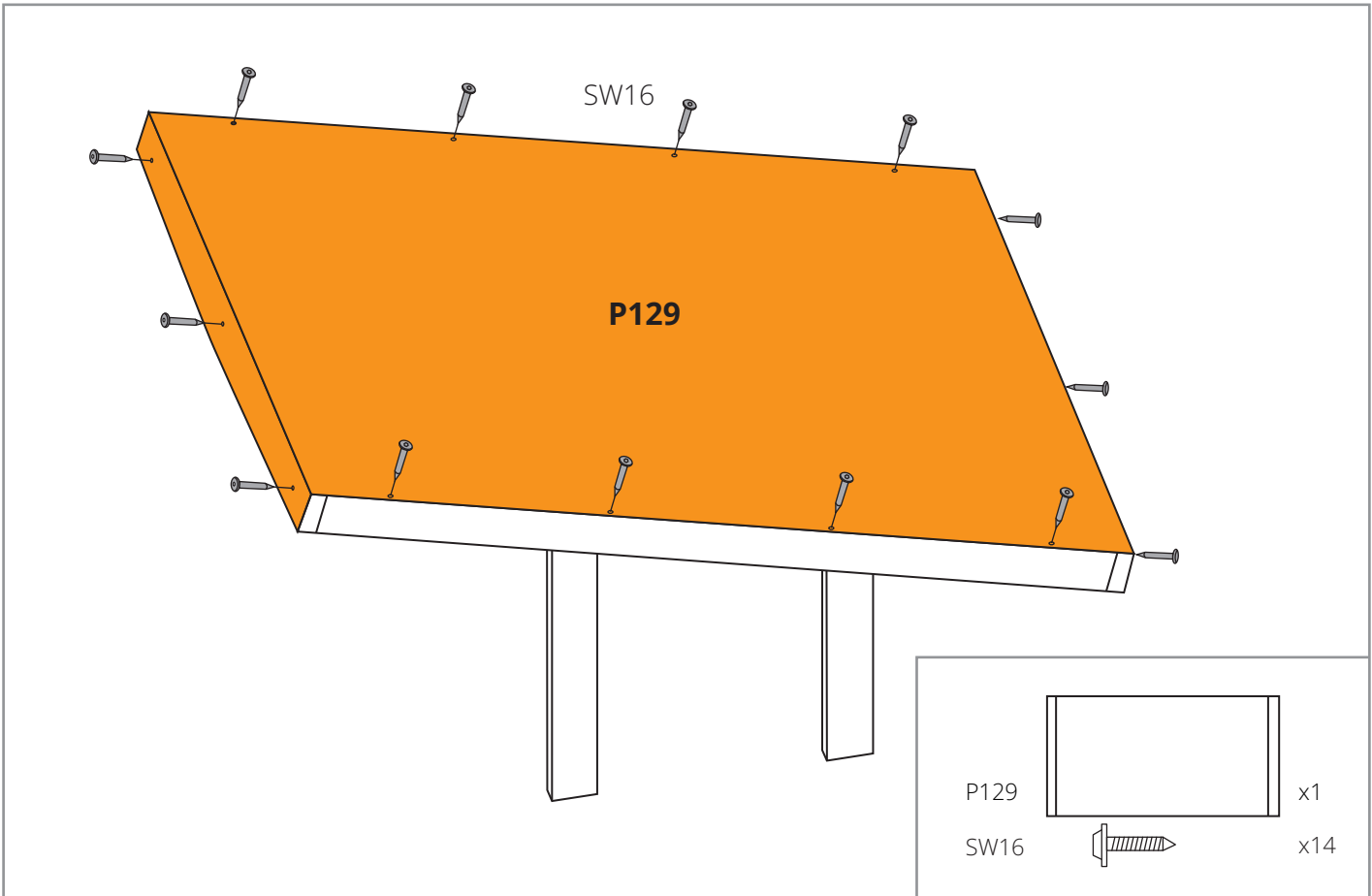

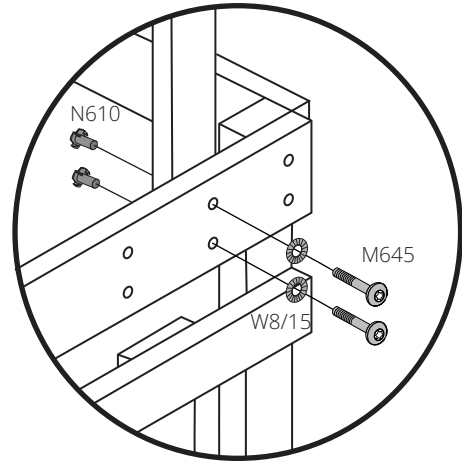
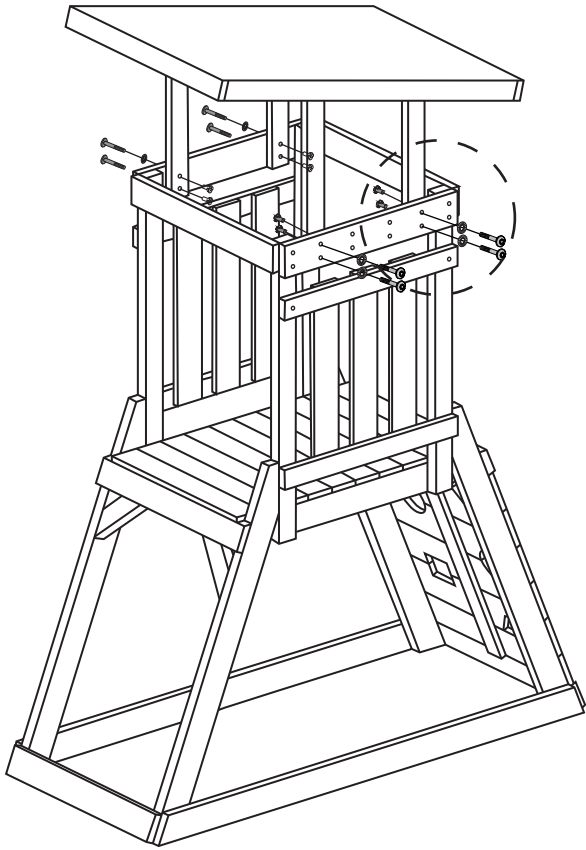

STEP15





X4

Attach the roof supports with rafter together.

M645		x8
N610		x8
W8/15		x8

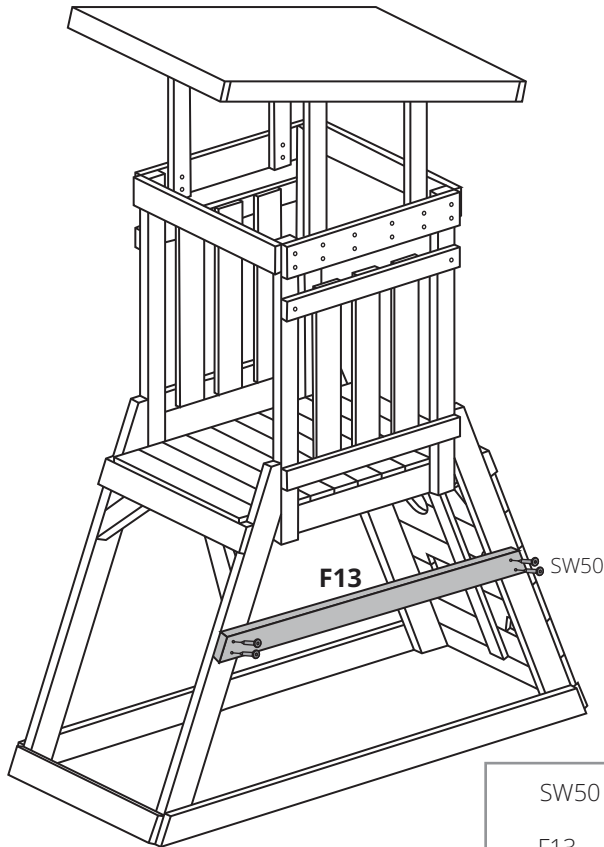
STEP16

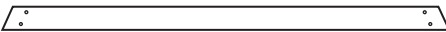

SW50		x4
F13		X1

STEP17

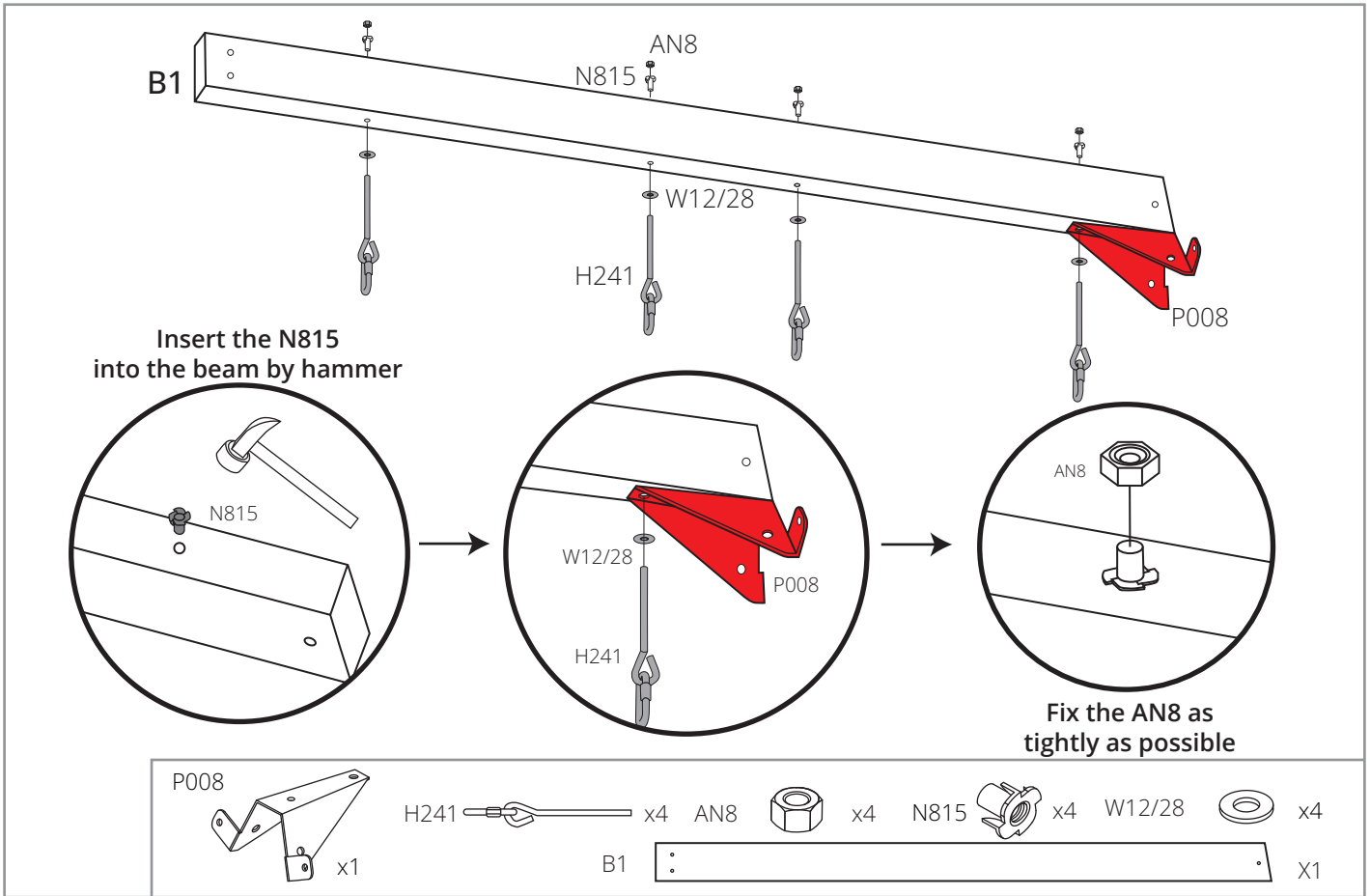

STEP18

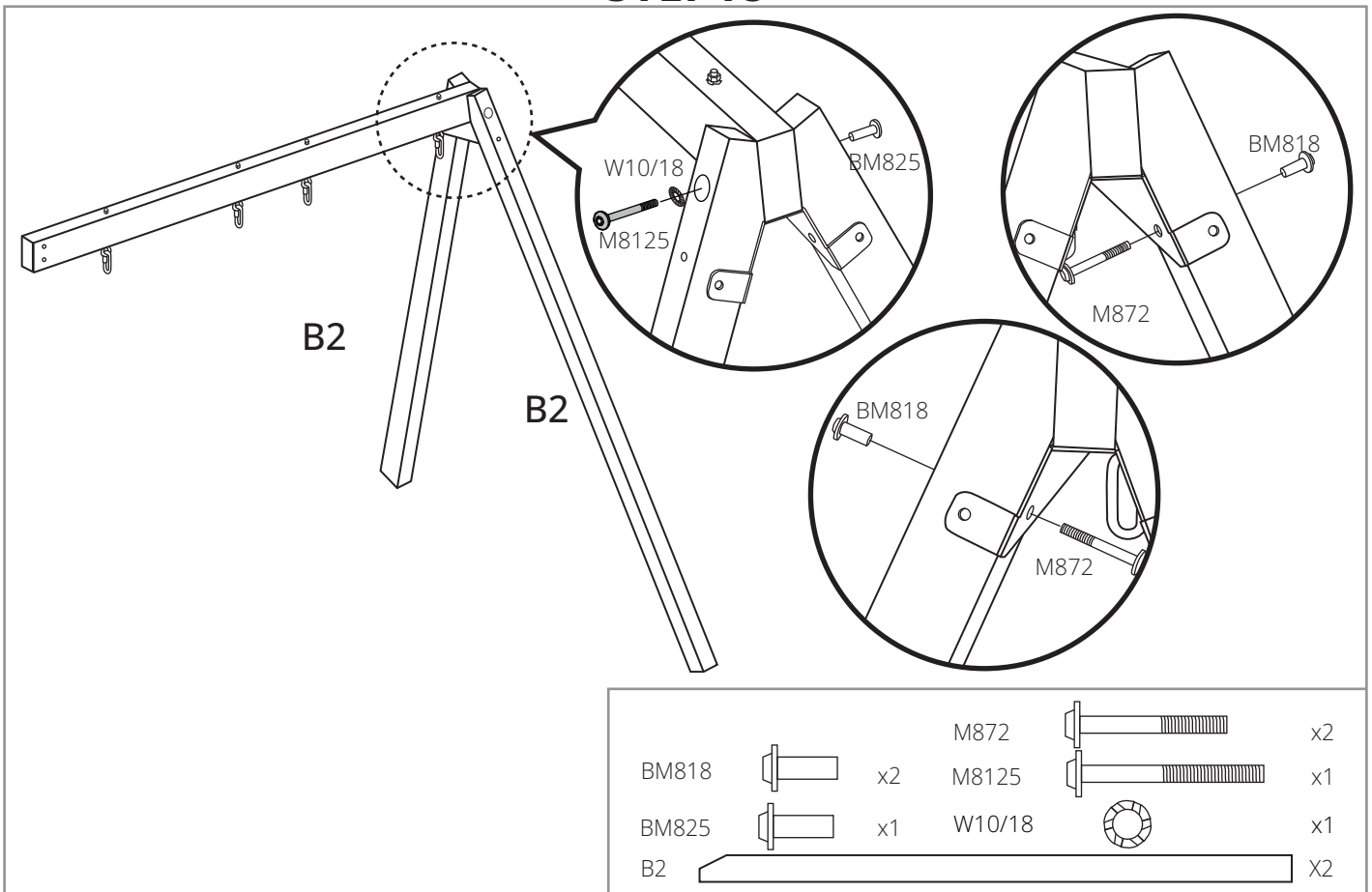

STEP19

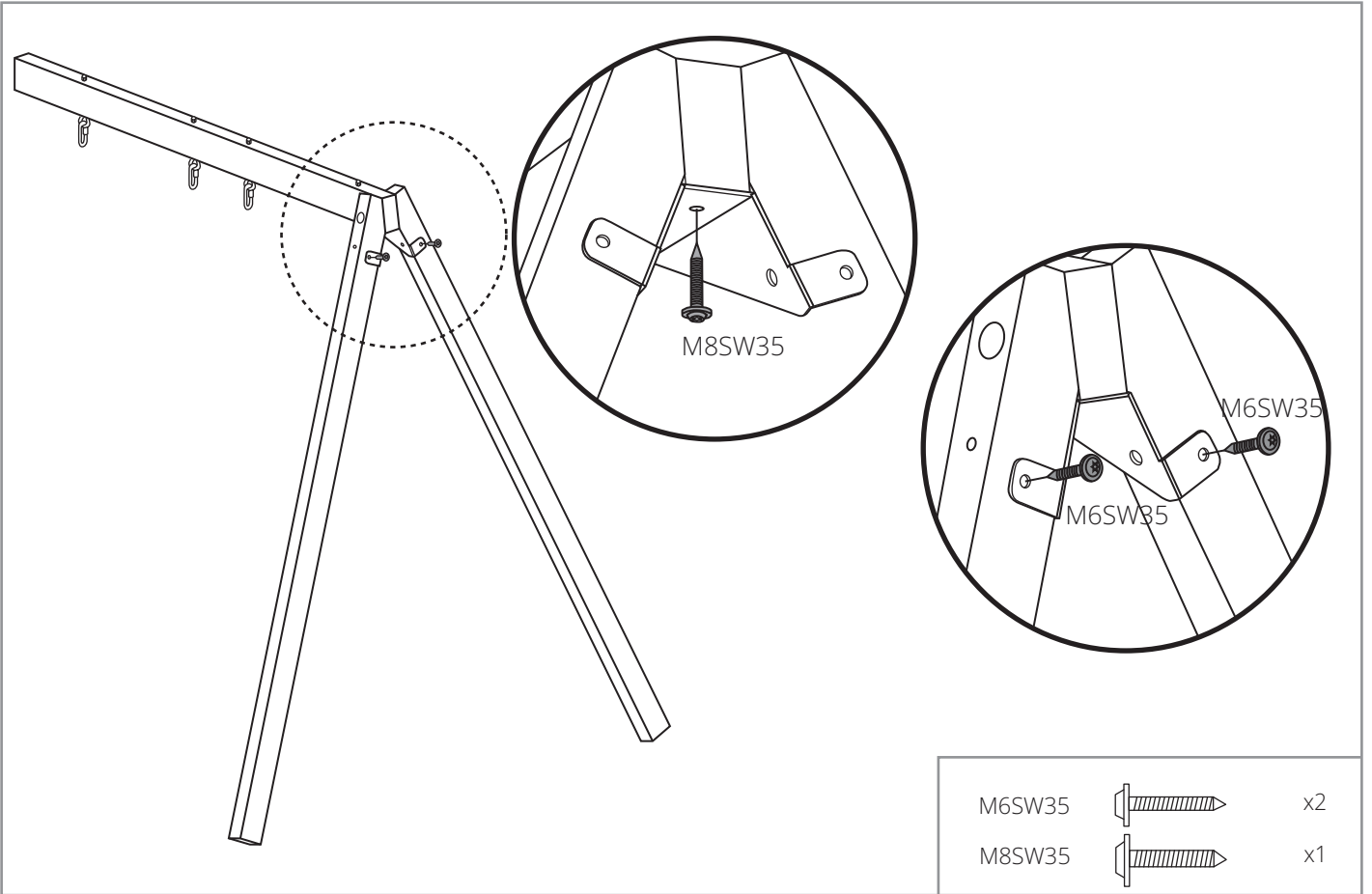

STEP20

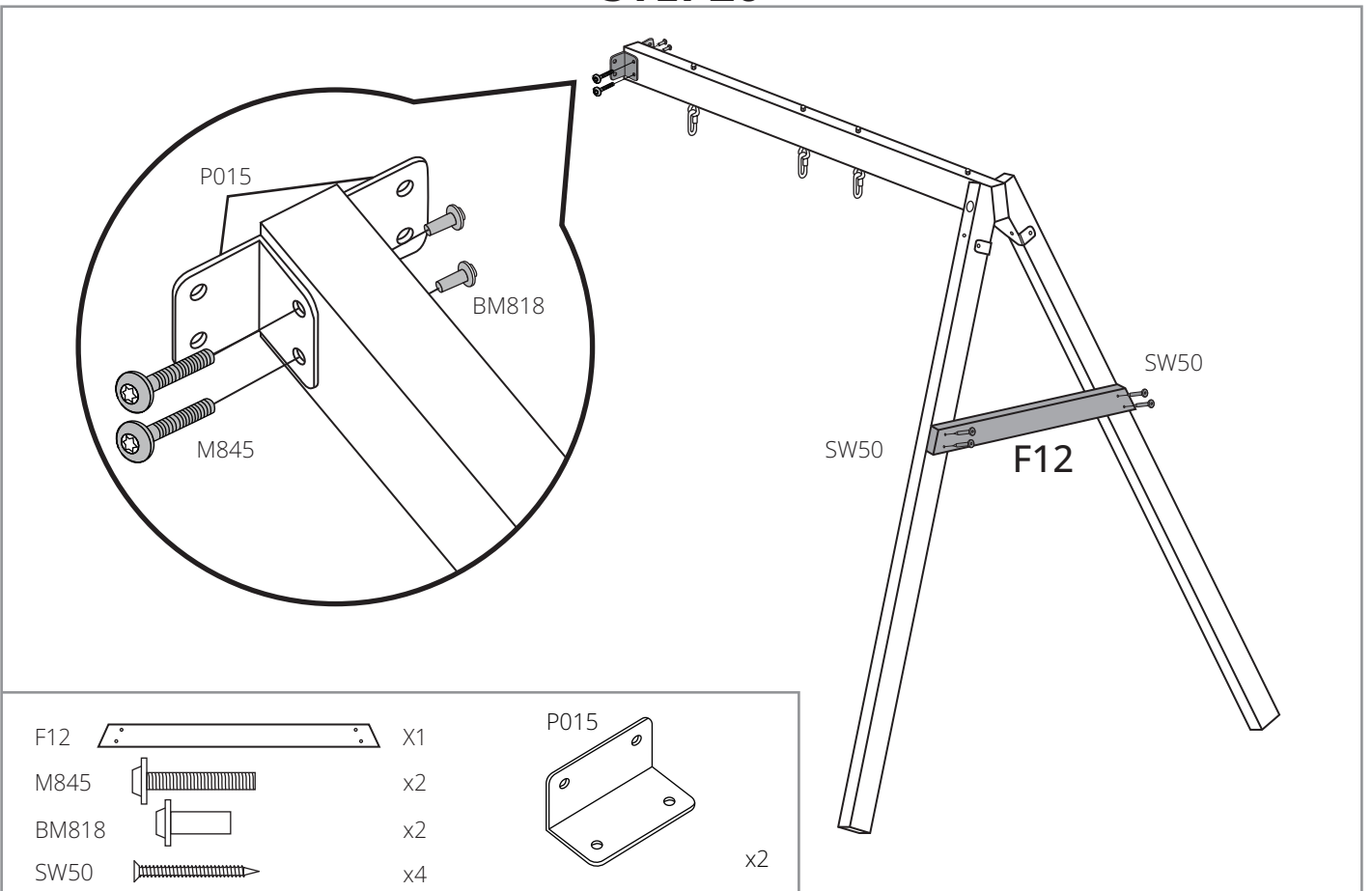

STEP21

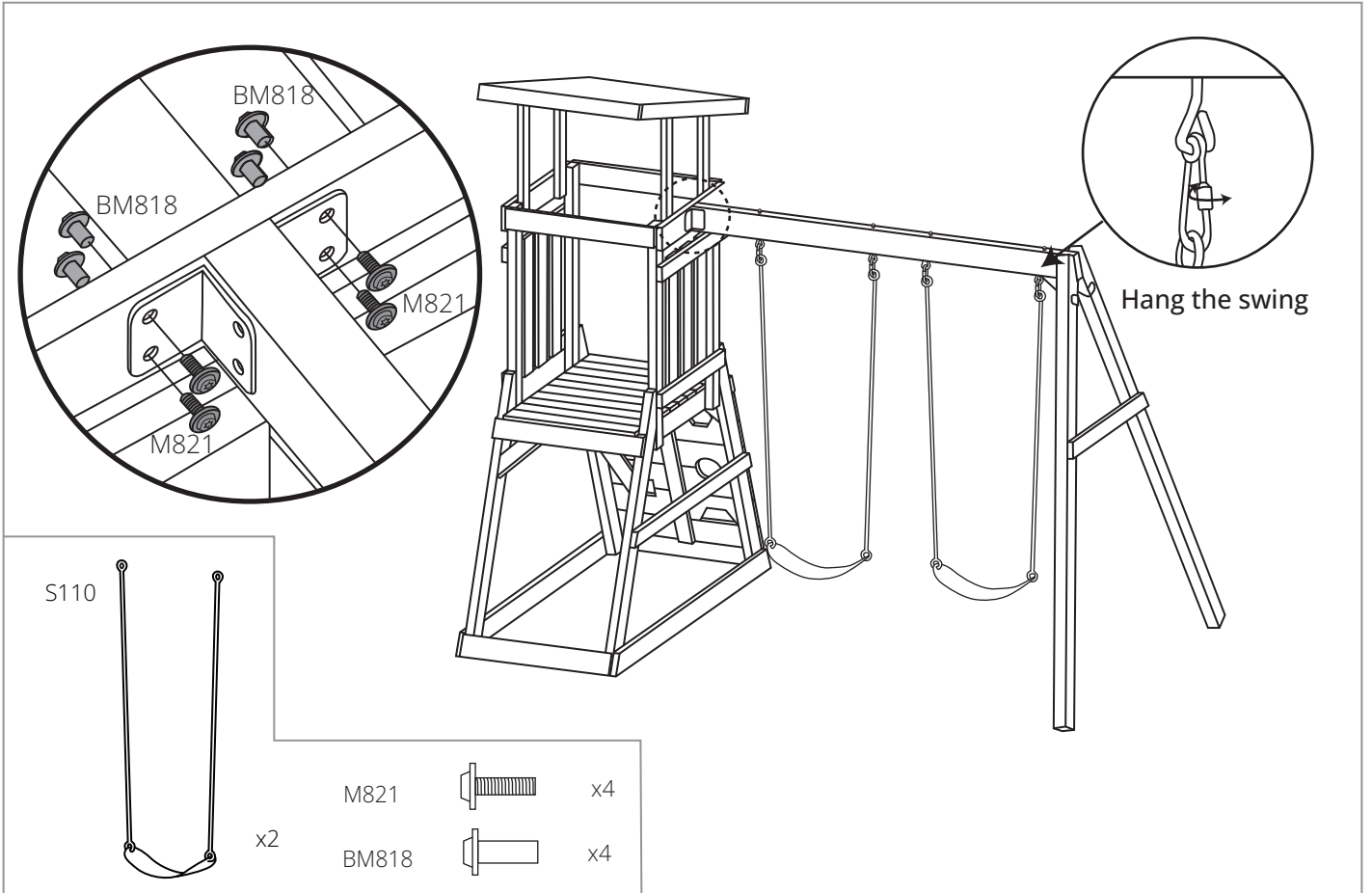

STEP22

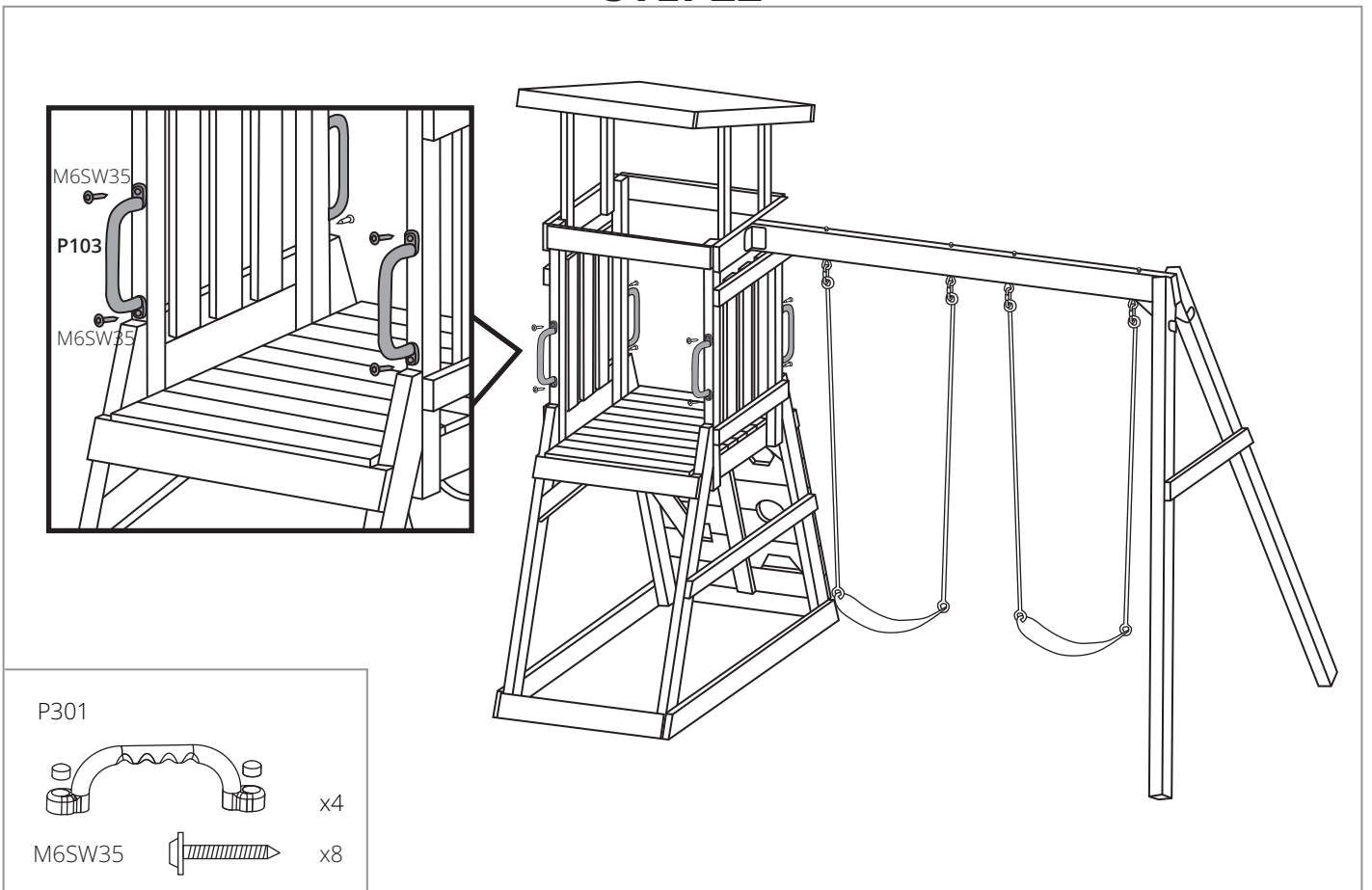

STEP23

Put the slide braces T1 under the floor boards and fix the slide with floor and slide braces together.

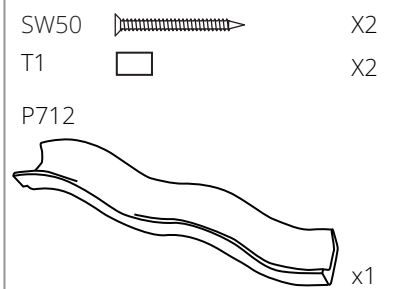
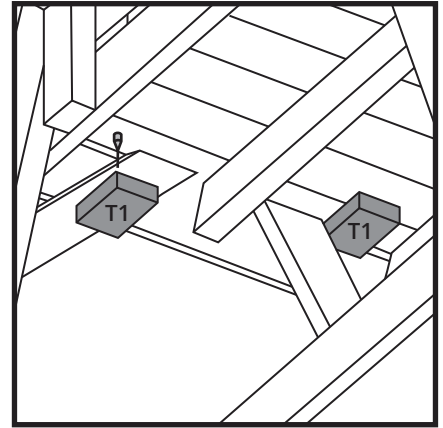
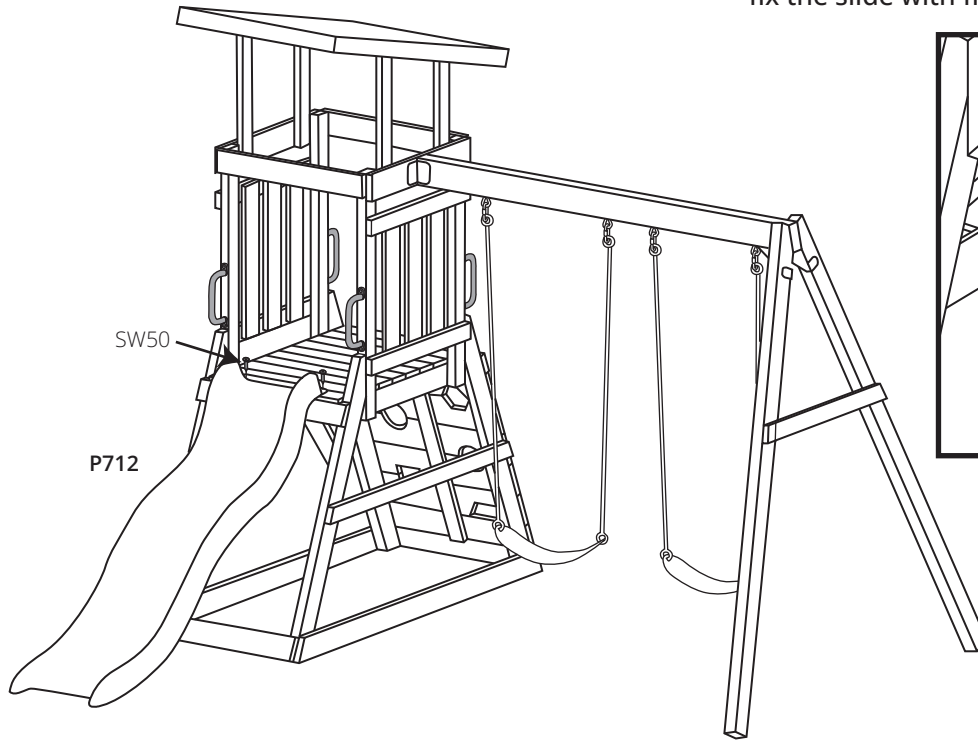

STEP24

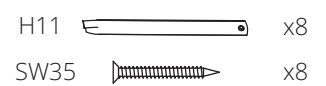
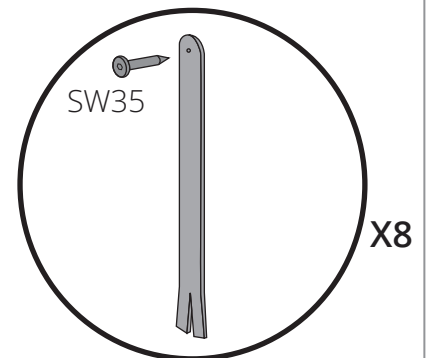
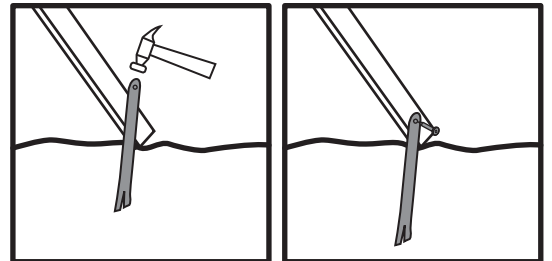
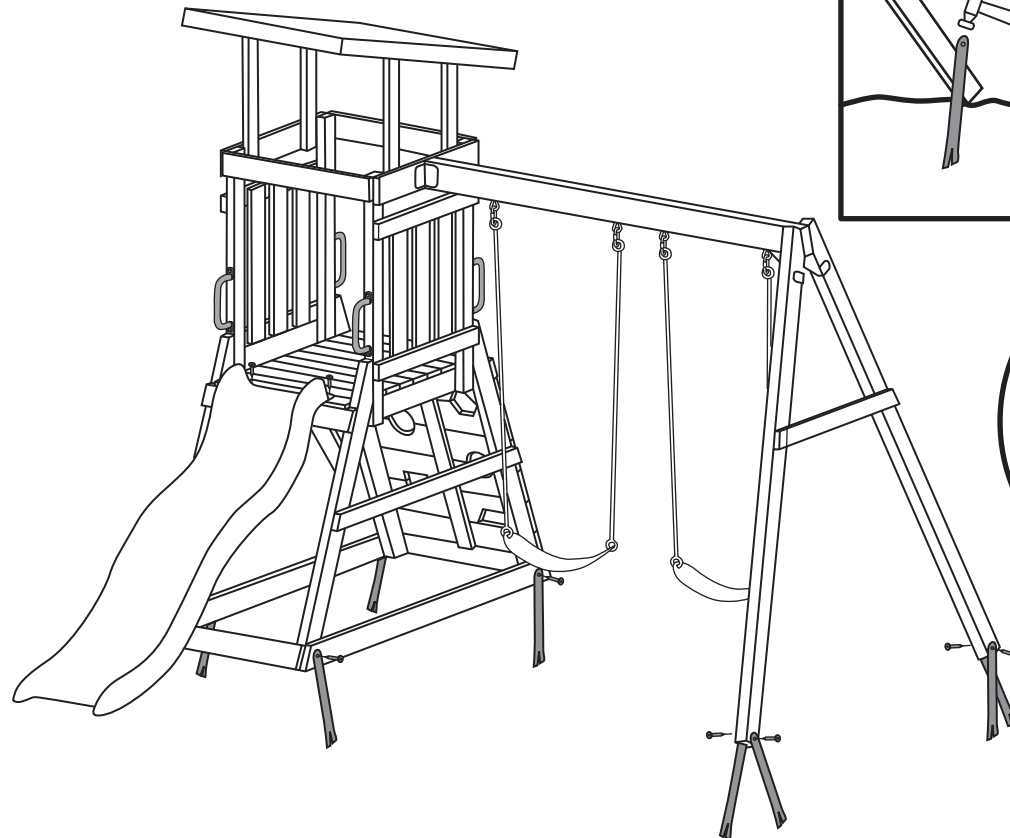

UK

If you have any questions, please contact our customer care center.

Our contact details are below:



0044-800-240-4004



enquiries@mhstar.co.uk

IMPORTER ADDRESS:

MH STAR UK LTD

Unit 27, Perivale Park,
Horsenden lane South
Perivale, UB6 7RH
MADE IN CHINA

FR

Si vous avez la moindre question, veuillez contacter notre centre d'assistance à la clientèle.

Nos coordonnées sont les suivantes:



0033-1-84166106



aosom@mhfrance.fr

Importé par:

MH France

2, rue Maurice Hartmann
92130 Issy-les-Moulineaux
France
Fabriqué en Chine

DE

Wenn Sie Fragen haben, wenden Sie sich bitte an unser Kundendienstzentrum.

Unsere Kontaktdaten stehen unten:



0049-0(40)-88307530



service@aosom.de

ADRESSE DES IMPORTEUR:

MH Handel GmbH
Wendenstraße 309
D-20537 Hamburg
Germany
IN CHINA HERGESTELLT

ES

Si tiene alguna pregunta, comuníquese con nuestro Centro de Atención al Cliente. Nuestros datos de contacto son los siguientes:



0034-931294512



atencioncliente@aosom.es

IMPORTADOR:

SPANISH AOSOM, S.L.

C/ ROC GROS, N° 15. 08550, ELS HOSTALETS DE
BALENYÀ, SPAIN.
B66295775

WWW.AOSOM.ES

ATENCIONCLIENTE@AOSOM.ES

TEL: 931294512

HECHO EN CHINA

PT

Se tiver alguma dúvida, por favor contacte o nosso Centro de Atendimento ao Cliente. Os nossos dados de contacto são os seguintes:



0034-931294512



info@aosom.pt.

IMPORTADOR:

SPANISH AOSOM, S.L

C.ROC GROS N.15, 08550. ELS HOSTALETS DE BALENYÀ
TEL: 931294512 (SEG-SEX DAS 7:30H ÀS 16:30H)

INFO@AOSOM.PT

WWW.AOSOM.PT

IT

In caso di dubbio, si prega di contattare il nostro centro assistenza clienti. I nostri dettagli di contatto sono di seguito:



0039-0249471447



clienti@aosom.it

IMPORTATO DA:

AOSOM Italy srl

Centro Direzionale Milanofiori

Strada 1 Palazzo F1

20057 Assago (MI)

P.I.: 08567220960

FATTO IN CINA

US

If you have any questions, please contact our customer care center.
Our contact details are below:



001-877-644-9366



customerservice@aosom.com

Imported by Aosom LLC
27150 SW Kinsman Rd Wilsonville, OR 97070 USA
MADE IN CHINA

CA

If you have any questions, please contact our customer care center.
Our contact details are below:

Si vous avez la moindre question, veuillez contacter notre centre d'assistance à la clientèle.
Nos coordonnées sont les suivantes:



416-792-6088



customerservice@aosom.ca

Imported by Aosom Canada Inc.
7270 Woodbine Avenue, Unit 307, Markham, Ontario Canada
L3R 4B9
MADE IN CHINA

Importé par Aosom Canada Inc.
7270 Woodbine Avenue, unité 307, Markham, Ontario Canada
L3R 4B9
FABRIQUÉ EN CHINE

