

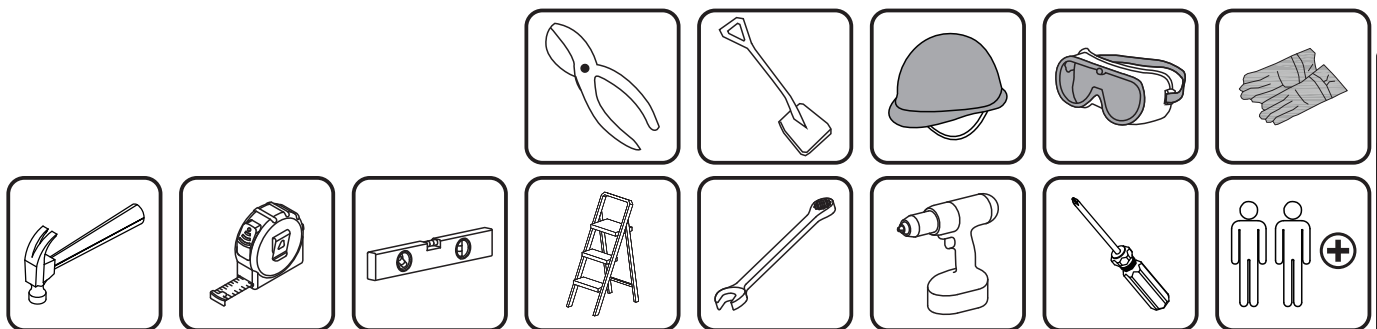

IN230900341V01\_GL

**845-951V01**

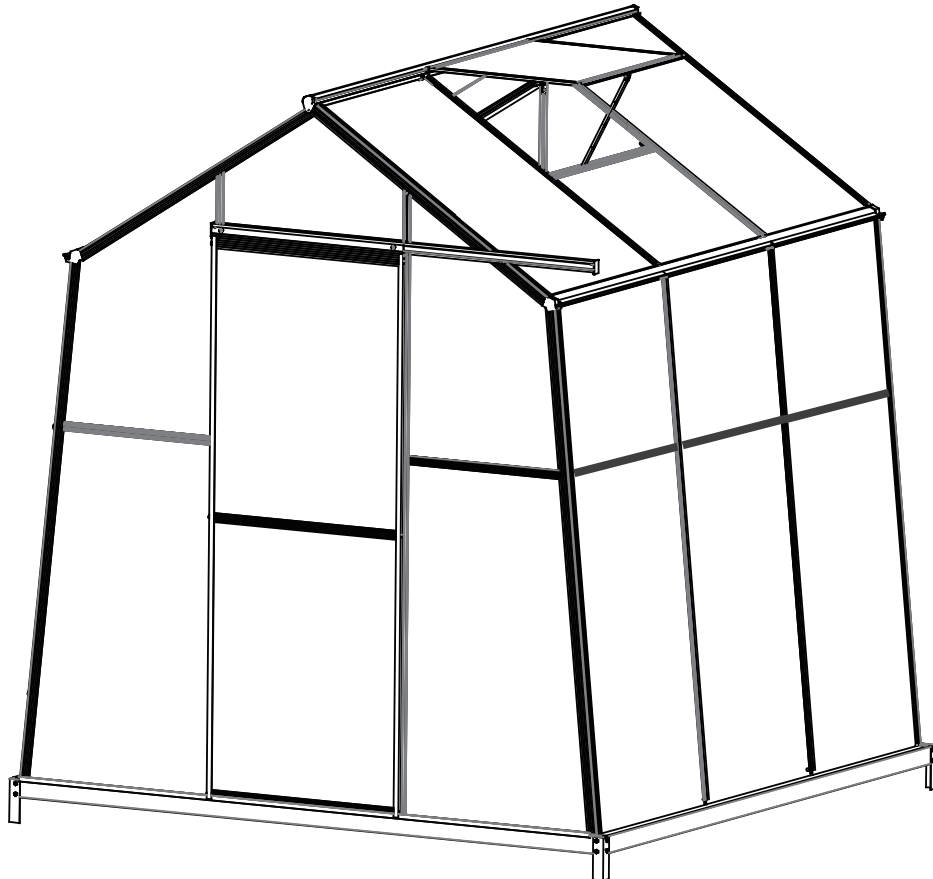

Tools Recommended

**EN\_IMPORTANT, RETAIN FOR FUTURE REFERENCE: READ CAREFULLY.**

**FR\_IMPORTANT: A LIRE ATTENTIVEMENT ET À CONSERVER POUR CONSULTATION ULTÉRIEURE.**

**ES\_IMPORTANTE, LEA Y GUARDE PARA FUTURAS REFERENCIAS.**

**PT\_IMPORTANTE, RETER PARA REFERÊNCIA FUTURA: LEIA ATENTAMENTE.**

**DE\_WICHTIG! SORGFÄLTIG LESEN UND FÜR SPÄTER NACHSCHLAGEN AUFBEWAHREN.**

**IT\_IMPORTANTE! CONSERVARE IL PRESENTE MANUALE PER FUTURO RIFERIMENTO E LEGGERLO ATTENTAMENTE.**

**EN****Dear customer,**

Thank you for purchasing this product. So that your appliance serves you well, please read all the instructions in this user's manual. If you have any questions, please contact our customer care center, Our contact details are below:

**FR****Cher client,**

Nous vous remercions d'avoir acheté ce produit. Afin que vous puissiez profiter pleinement de votre appareil, veuillez lire toutes les instructions de ce manuel d'utilisation. Si vous avez la moindre question, veuillez contacter notre centre d'assistance à la clientèle, Nos coordonnées sont les suivantes:

**DE****Sehr geehrter Kunde,**

Vielen Dank, dass Sie dieses Produkt erworben haben. Damit Ihr Gerät Ihnen gute Dienste leistet, lesen Sie bitte alle Hinweise in diesem Benutzerhandbuch. Wenn Sie Fragen haben, wenden Sie sich bitte an unser Kundendienstzentrum, Unsere Kontaktdaten stehen unten:

**ES****Queridos clientes,**

Gracias por comprar este producto. Para que su electrodoméstico le sirva mejor, lea todas las instrucciones de este manual del usuario. Si tiene alguna pregunta, comuníquese con nuestro Centro de Atención al Cliente, Nuestros datos de contacto son los siguientes:

**PT****Caros clientes,**

Obrigado por adquirir este produto. Para que o seu aparelho o sirva melhor, leia todas as instruções deste manual do utilizador. Se tiver alguma dúvida, por favor contacte o nosso Centro de Atendimento ao Cliente, Os nossos dados de contacto são os seguintes:

**IT****Caro Cliente,**

Grazie per aver acquistato questo prodotto. Per servirti meglio con questo apparecchio ti prego di leggere tutte le istruzioni in presente manuale utente. In caso di dubbio, si prega di contattare il nostro centro assistenza clienti, I nostri dettagli di contatto sono di seguito:

Country	 Phone	 Email
US	001-877-644-9366	customerservice@aosom.com
CA	416-792-6088	customerservice@aosom.ca
UK	0044-800-240-4004	enquiries@mhstar.co.uk
DE	0049-0(40)-88307530	service@aosom.de
FR	0033-1-84166106	aosom@mhfrance.fr
ES	0034-931294512	atencioncliente@aosom.es
PT	0034-931294512	info@aosom.pt
IT	0039-0249471447	clienti@aosom.it

**EN**

**TO PREVENT INJURY, READ AND UNDERSTAND THE GREENHOUSE ASSEMBLY INSTRUCTIONS BEFORE USE.**

### **GENERAL SAFETY, WARNINGS AND PRECAUTIONS**

#### **KEEP WORK AREA CLEAN AND DRY.**

Cluttered, damp or wet work areas invite injuries.

**STAY ALERT.** Watch what you are doing at all times. Use common sense. Do not use the greenhouse when you are tired or distracted from the job at hand. It is recommended to use gloves for assembling the greenhouse.

#### **MAINTAIN THIS PRODUCT WITH CARE.**

Keep the greenhouse clean and dry for better performance: maintenance should be performed regularly.

#### **USE THE RIGHT PRODUCT FOR THE JOB.**

Do not attempt to force a small product to do the work of a larger industrial product. There are certain applications for which the greenhouse was designed. It will do the job better and more safely in the manner for which it was intended. Do not modify the greenhouse and do not use the greenhouse for a purpose for which it was not intended.

#### **MAINTAIN A SAFE WORKING ENVIRONMENT.**

Keep the work area tidy. Make sure there is adequate surrounding workspace. Avoid high traffic areas. Always keep the work area free of obstructions, grease, oil, trash and other debris.

#### **PROPER GREENHOUSE LOCATION.**

Make sure the greenhouse is located on a flat level surface.

**FR**

**POUR ÉVITER LES RISQUES DE BLESSURES, VEILLEZ LIRE ET COMPRENDRE LES INSTRUCTIONS DE MONTAGE DE LA SERRE AVANT DE L'UTILISER.**

### **SÉCURITÉ GÉNÉRALE, AVERTISSEMENTS ET PRÉCAUTIONS**

#### **GARDER LA ZONE DE TRAVAIL PROPRE ET SÈCHE.**

Les zones de travail encombrées, humides ou mouillées sont propices aux blessures.

**RESTEZ VIGILANT.** Surveillez ce que vous faites à tout moment. Faites preuve de bon sens. N'utilisez pas la serre lorsque vous êtes fatigué ou distrait du travail en cours. Il est recommandé d'utiliser des gants pour le montage de la serre.

#### **ENTRETIENEZ CE PRODUIT AVEC SOIN.**

Gardez la serre propre et sèche pour un meilleur rendement : l'entretien doit être effectué régulièrement.

#### **UTILISEZ LE PRODUIT APPROPRIÉ POUR LE TRAVAIL À EFFECTUER.**

N'essayez pas de forcer un petit produit à faire le travail d'un produit industriel plus important. La serre a été conçue pour certaines applications. Elle fera mieux le travail pour lequel elle a été conçue et de manière plus sûre. Ne modifiez pas la serre et n'utilisez pas la serre à des fins pour lesquelles elle n'a pas été conçue.

#### **MAINTENIR UN ENVIRONNEMENT DE TRAVAIL SÛR.**

Maintenez l'espace de travail en ordre. Assurez-vous que l'espace de travail environnant est adéquat. Évitez les zones à forte circulation. Maintenez la zone de travail toujours libre de tout obstacle, graisse, huile, déchets et autres débris.

#### **EMPLACEMENT ADÉQUAT DE LA SERRE.**

Veillez à ce que la serre soit située sur une surface plane et de niveau.

**ES**

**PARA PREVENIR LESIONES, LEA Y COMPRENDA LAS INSTRUCCIONES DE MONTAJE DEL INVERNADERO ANTES DE USARLO.**

### **SEGURIDAD GENERAL, ADVERTENCIAS Y PRECAUCIONES**

#### **MANTENGA EL ÁREA DE TRABAJO LIMPIA Y SECA.**

Las áreas de trabajo desordenadas, húmedas o mojadas pueden provocar lesiones. **MANTÉNGASE ALERTA.** Vigile lo que está haciendo en todo momento con el conocimiento común. No use el invernadero cuando esté cansado o distraído del trabajo en cuestión. Se recomienda utilizar guantes para montar el invernadero.

#### **MANTENGA ESTE PRODUCTO CON CUIDADO.**

Mantenga el invernadero limpio y seco para un mejor rendimiento: el mantenimiento debe realizarse con regularidad.

#### **USE EL PRODUCTO ADECUADO PARA EL TRABAJO.**

No intente forzar a un producto pequeño a hacer el trabajo que debe hacerse por un producto industrial más grande. Existen determinadas aplicaciones para las que se ha diseñado el invernadero. Puede hacer el trabajo mejor y con más seguridad si se usa en la manera para la que fue diseñado. No modifique el invernadero y no lo utilice para fines para los que no fue diseñado.

#### **MANTENGA UN AMBIENTE DE TRABAJO SEGURO.**

Mantenga el área de trabajo ordenada. Asegúrese de que haya un espacio de trabajo circundante adecuado. No lo use en las áreas de mucho tráfico. Mantenga siempre el área de trabajo libre de obstrucciones, grasa, aceite, basura y otros desechos.

#### **UBICACIÓN APROPIADA DEL INVERNADERO.**

Asegúrese de que el invernadero esté ubicado en una superficie plana y nivelada.

**PT**

### **SEGURANÇA GERAL, AVISOS E PRECAUÇÕES**

#### **MANTER A ÁREA DE TRABALHO LIMPA E SECA.**

As áreas de trabalho desorganizadas, húmidas ou molhadas provocam lesões. **ATENÇÃO:** Esteja sempre atento ao que está a fazer. Use comum sentido. Não utilizar a estufa quando estiver esgotado ou distraído do trabalho em questão. Recomenda-se o uso de luvas para montar a estufa.

#### **MANTENHA ESTE PRODUTO COM PRUDÊNCIA.**

Mantenha a estufa limpa e seca para um melhor desempenho: a manutenção deve ser feita regularmente.

#### **UTILIZAR O PRODUTO CERTO PARA O FUNCIONAMENTO.**

Não tentar forçar um produto pequeno a fazer o funcionamento de um produto industrial maior. Existem certas aplicações para as quais o estufa foi concebida. Fará o trabalho de forma melhor e mais segura da forma a que foi concebido. Não modificar a estufa e não utilizar a estufa para um fim para o qual não foi concebida.

#### **MANTER UM AMBIENTE DE TRABALHO SEGURO.**

Manter a área de trabalho arrumada. Certificar-se de que existe um ambiente de trabalho adequado espaço o suficiente. Manter sempre a área de trabalho livre de obstruções, gorduras, óleo, lixo e outros detritos.

#### **LOCALIZAÇÃO ADEQUADA DA ESTUFA.**

Certifique-se de que a estufa está localizada numa superfície de nivelada.

**DE**

**Um Verletzungen zu vermeiden, lesen und verstehen Sie bitte vor dem Gebrauch die Anweisungen zur Montage des Gewächshauses.**

### **Allgemeine Sicherheit, Warnhinweise und Vorsichtsmaßnahmen**

#### **Halten Sie Arbeitsbereich sauber und trocken .**

Überfüllte, feuchte oder nasse Arbeitsbereiche können zu Verletzungen führen. **WACHSAM BLEIBEN.** Beobachten Sie jederzeit, was Sie tun. Verwenden Sie gesunden Menschenverstand. Verwenden Sie das Gewächshaus nicht, wenn Sie müde oder von der anstehenden Aufgabe abgelenkt sind. Es wird empfohlen, für die Montage des Gewächshauses Handschuhe zu tragen.

#### **Behalten Sie dieses Produkt mit Pflege**

Halten Sie das Gewächshaus sauber und trocken, um eine bessere Leistung zu erzielen: Regelmäßige Wartungsarbeiten sollten durchgeführt werden.

#### **Verwenden Sie das richtige Produkt für den Job**

Versuchen Sie nicht, ein kleines Produkt zu zwingen, die Arbeit eines größeren Industrieprodukts zu erledigen. Es gibt bestimmte Anwendungen, für die das Gewächshaus konzipiert wurde. Es wird die Arbeit besser und sicherer in der Weise erledigen, für die es bestimmt war. Ändern Sie das Gewächshaus nicht und verwenden Sie es nicht für Zwecke, für die es nicht vorgesehen war.

#### **Sorgen Sie für ein sicheres Arbeitsumfeld.**

Halten Sie den Arbeitsbereich sauber und ordentlich. Stellen Sie sicher, dass Sie genügend Arbeitsfläche um sich haben. Vermeiden Sie stark frequentierte Bereiche. Halten Sie den Arbeitsbereich immer frei von Hindernissen, Fett, Öl, Müll und anderen Fremdkörpern.

#### **Richtige Gewächshauslage.**

Stellen Sie sicher, dass sich das Gewächshaus auf einer ebenen Fläche befindet.

**IT**

**PER PREVENIRE LESIONI, LEGGETE E COMPRENDETE LE ISTRUZIONI DI ASSEMBLAGGIO DELLA SERRA PRIMA DELL'USO.**

### **SICUREZZA GENERALE, AVVERTENZE E PRECAUZIONI**

#### **MANTENETE L'AREA DI LAVORO PULITA E ASCIUTTA.**

Le aree di lavoro disordinate, umide o bagnate potrebbero provocare lesioni. **STAI ATTENTO.** Stai attento su cosa stai facendo in ogni momento. Usa il senso comune e non usare la serra quando sei stanco o distratto nel lavoro da svolgere. Si consiglia di utilizzare i guanti per l'assemblaggio della serra.

#### **MANTENETE QUESTO PRODOTTO CON CURA.**

Mantieni la serra pulita e asciutta per prestazioni migliori: la manutenzione deve essere eseguita regolarmente.

#### **UTILIZZATE IL PRODOTTO GIUSTO PER IL LAVORO.**

Non tentare di forzare un prodotto piccolo a svolgere un lavoro di un prodotto industriale più grande. Ci sono alcune applicazioni per le quali il prodotto è stato progettato. Il prodotto funzionerà meglio e più sicuro nel modo per cui è stato progettato. Non modificare la serra e non utilizzare la serra per scopi per i quali non è stata concepita.

#### **MANTENETE UN AMBIENTE DI LAVORO SICURO.**

Tieni in ordine l'area di lavoro. Assicurati che ci sia uno spazio di lavoro circostante adeguato. Evita le zone di molto traffico. Mantieni sempre l'area di lavoro libera da ostruzioni, grasso, olio, rifiuti e altri detriti.

#### **POSIZIONE ADEGUATA DELLA SERRA.**

Assicurati che la serra si trovi su una superficie piana e livellata.

**EN\_** ABOUT THIS MANUAL LEGENDS  
**FR\_** À PROPOS DE CE MANUEL LÉGENDES  
**ES\_** SOBRE ESTE MANUAL LEYENDAS  
**PT\_** SOBRE ESTE MANUAL LEGENDAS  
**DE\_** ÜBER DIESES HANDBUCH LEGENDEN  
**IT\_** SULLE LEGGENDE DI QUESTO MANUALE



**EN\_** Steps. Follow the steps in alphabetic order, from Step A to Step B, etc.  
**FR\_** Les étapes. Suivez les étapes dans l'ordre alphabétique, de l'étape A à l'étape B, etc.  
**ES\_** Pasos. Siga los pasos en orden alfabético, del Paso A al Paso B, etc.  
**PT\_** Passos. Siga os passos por ordem alfabética, do passo A ao passo B, etc.  
**DE\_** Schritte. Befolgen Sie die Schritte in alphabetischer Reihenfolge, von Schritt A zu Schritt B usw.  
**IT\_** Passi. Seguire le fasi in ordine alfabetico, dalla fase A alla fase B, ecc.



**EN\_** Part No. Each part is labeled with its Part No.  
**FR\_** Numéro de pièce Chaque pièce est étiquetée avec son numéro de pièce.  
**ES\_** N° de pieza Cada pieza está etiquetada con su N° de pieza.  
**PT\_** N.º de peça Cada peça está identificada com o seu N.º de peça.  
**DE\_** Teile-Nr. Jedes Teil ist mit seiner Teile-Nr. beschriftet.  
**IT\_** Ogni pezzo è etichettato con il suo codice articolo.



**EN\_** If you meet some difficult during the assembly, please loosen the relevant screws for adjustment first, and then tighten the screws again.  
**FR\_** Si vous rencontrez des difficultés lors du montage, veuillez d'abord desserrer les vis correspondantes pour les ajustements, puis les resserrer.  
**ES\_** Si encuentra alguna dificultad durante el montaje, primero afloje los tornillos correspondientes para ajustar, y luego vuelva a apretarlos.  
**PT\_** Se encontrar alguma dificuldade durante a montagem, por favor solte os parafusos relevantes para ajuste primeiro, e depois aperte novamente os parafusos.  
**DE\_** Wenn Sie während der Montage auf Schwierigkeiten stoßen, lösen Sie bitte zuerst die entsprechenden Schrauben zur Einstellung und ziehen Sie die Schrauben dann wieder fest.  
**IT\_** In caso di difficoltà durante il montaggio, allentare innanzitutto le viti prima della regolazione, quindi stringere nuovamente le viti.

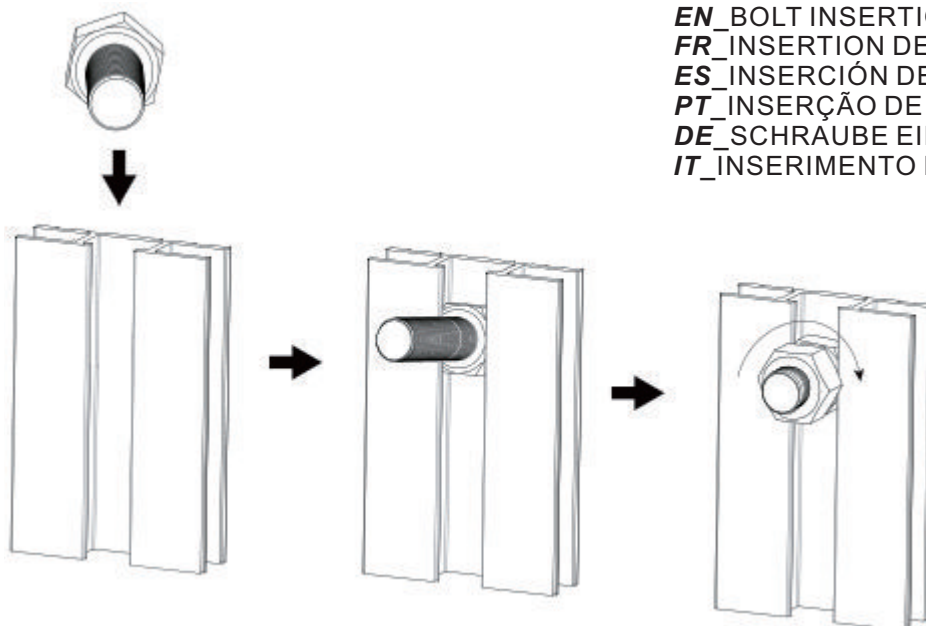

**EN**\_BOLT INSERTION  
**FR**\_INSERTION DES BOULONS  
**ES**\_INSERCIÓN DE PERNOS  
**PT**\_INSERÇÃO DE PARAFUSOS  
**DE**\_SCHRAUBE EINSETZEN  
**IT**\_INSERIMENTO DEI BULLONI

**EN** Several steps in this manual involve inserting F4 Bolts into the groove of Aluminum profiles as a preparation for further installation. Dia-grams above illustrate how to use such inserted bolts.

#### F4 BOLTS AND NUTS

Part No. F4 refers to both the bolt and the nut. In some steps only the bolt or the nut will be used and in other steps the whole set will be used. Check the specific Part List in each step.

**FR** Plusieurs étapes de ce manuel impliquent l'insertion de boulons F4 dans la rainure des profilés en aluminium afin de préparer l'installation ultérieure. Les diagrammes ci-dessus illustrent l'utilisation de ces boulons insérés.

#### BOULONS ET ÉCROUS F4

La référence F4 désigne à la fois le boulon et l'écrou. Dans certaines étapes, seul le boulon ou l'écrou sera utilisé, alors que dans d'autres étapes, l'ensemble sera utilisé. Consultez la liste des pièces spécifiques à chaque étape.

**ES** Varios pasos de este manual implican la inserción de pernos F4 en la ranura de los perfiles de aluminio como preparación para su posterior instalación. Los dia-gramas anteriores ilustran cómo utilizar dichos pernos insertados.

#### TORNILLOS Y TUERCAS F4

La referencia F4 se refiere tanto al tornillo como a la tuerca. En algunos pasos sólo se utilizará el tornillo o la tuerca y en otros pasos se utilizará todo el conjunto. Compruebe la lista de piezas específica de cada paso.

**PT** Vários passos deste manual envolvem a inserção de parafusos F4 na ranhura dos perfis de alumínio como preparação para a instalação posterior. Os diagramas acima ilustram como utilizar esses parafusos inseridos.

#### PARAFUSOS E PORCAS F4

O número de peça F4 refere-se tanto ao parafuso como à porca. Em alguns passos, apenas o parafuso ou a porca serão utilizados e, noutros passos, será utilizado o conjunto completo. Verifique a lista de peças específica de cada passo.

**DE** Mehrere Schritte in diesem Handbuch beinhalten das Einsetzen von F4-Schrauben in die Nuten von Aluminiumprofilen als Vorbereitung für die weitere Montage. Die obigen Diagramme veranschaulichen die Verwendung solcher eingefügter Bolzen.

#### F4 SCHRAUBEN UND MUTTERN















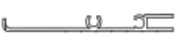
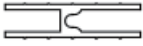



Die Teile-Nr. F4 bezieht sich sowohl auf die Schraube als auch auf die Mutter. In einigen Schritten wird nur die Schraube oder die Mutter verwendet, in anderen Schritten wird der gesamte Satz verwendet. Überprüfen Sie die spezifische Teileliste in jedem Schritt.





















**IT** Diverse fasi di questo manuale prevedono l'inserimento di bulloni F4 nella scanalatura dei profili di alluminio come preparazione per la successiva installazione. I diagrammi qui sopra illustrano come utilizzare i bulloni inseriti.





















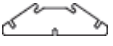

#### BULLONI E DADI F4

Il codice F4 si riferisce sia al bullone che al dado. In alcune fasi si utilizzerà solo il bullone o il dado, mentre in altre fasi si utilizzerà l'intero set. Controllare l'elenco dei componenti specifico di ogni fase.

# PARTS LIST

Part No.	Part	Qty.
1		2
2		2
3		4
F3		16
Part No.	Part	Qty.
D1		1
D2		1
D3		2
D4		1
P1		2
F1		8
Part No.	Part	Qty.
W1		1
W2		2
W3		1
W4		1
P2		1
S8		1
S9		1
F2		4
F8		1
F9		1



Part No.	Part	Qty.
4		2
5		1
6		1
7		4
8		2
9L		1
9R		1
10L		1
10R		1
12L		2
12R		2
12		7
13		1
15		1
16		4
17		1
18		1
19		4
20		4
22		8
25		2

Part No.	Part	Qty.
P3L		2
P3R		2
P4L		2
P4R		2
P5		1
P6		1
P7		1
P8		6
P8A		6
P9		5
P10		1
B2		8
B4		4
B5		4
B6		2
B7		1
B15		22
S6L		2
S6R		2
S5		2
S7		2
F6		2
F4		152

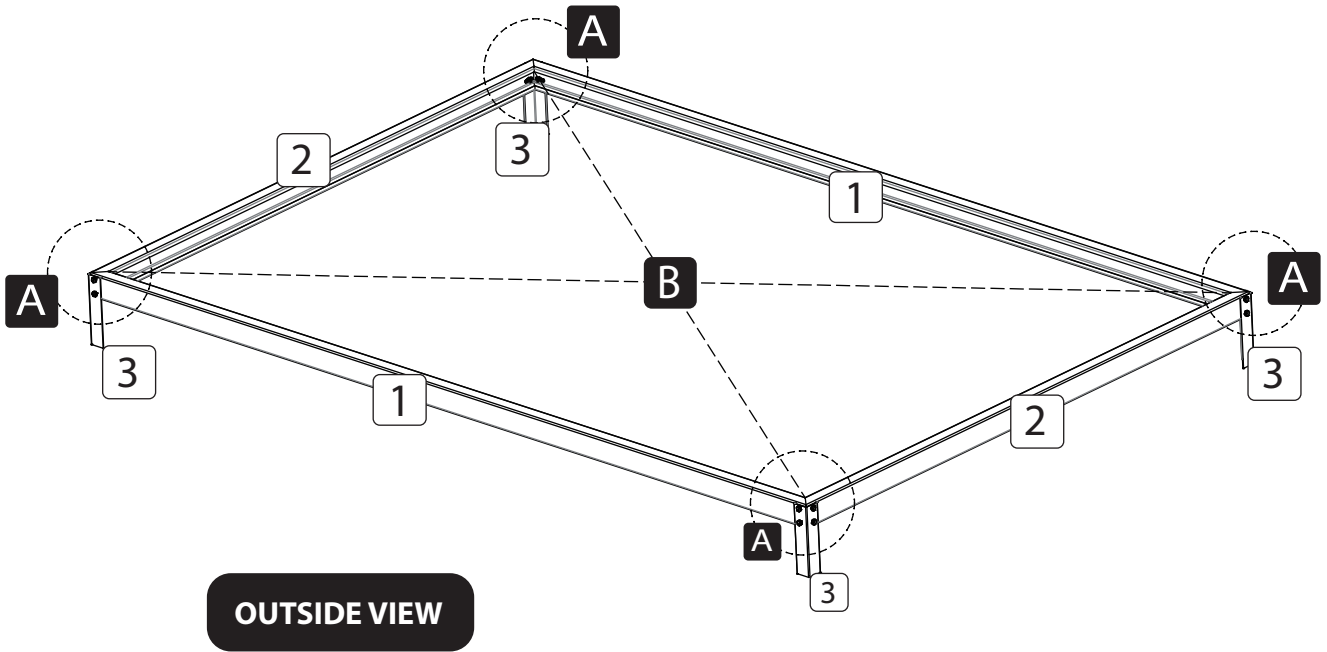

# Assembling of Pre-fabricated Base

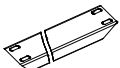
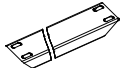

Part No.	Part	Qty.
1		2
2		2
3		4
F3		16

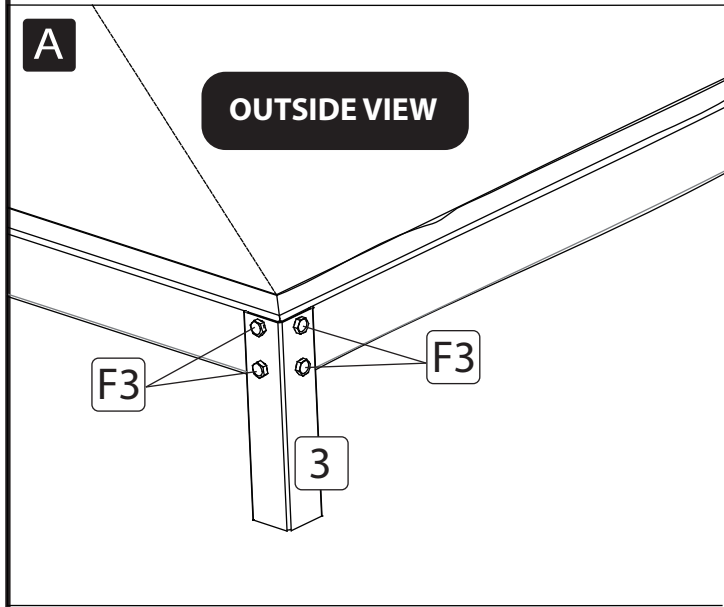



**EN\_** Take the fully assembled base to the chosen site and secure the base to the ground.

**TIP:** measure the length of the two diagonal of the base to make sure that the base is in a square shape.

Use a level to make sure the secured base is at.

**FR\_** Apportez la base entièrement assemblée sur le site choisi et fixez-la au sol.

**CONSEIL :** mesurez la longueur des deux diagonales de la base pour vous assurer qu'elle est bien carrée.

Utilisez un niveau pour vous assurer que la base fixée est à l'équerre.

**ES\_** Lleva la base completamente montada al lugar elegido y fijala al suelo.

**CONSEJO:** mide la longitud de las dos diagonales de la base para asegurarte de que la base tiene forma cuadrada.

Utilice un nivel para asegurarse de que la base fijada está a.

**PT\_** Leve a base completamente montada para o local escolhido e fixe-a ao solo.

**SUGESTÃO:** meça o comprimento das duas diagonais da base para se certificar de que a base tem uma forma quadrada.

Utilize um nível para se certificar de que a base fixada está no ponto.

**DE\_** Bringen Sie den fertig montierten Sockel an den gewählten Standort und befestigen Sie ihn auf dem Boden.

**TIPP:** Messen Sie die Länge der beiden Diagonalen des Sockels, um sicherzustellen, dass der Sockel eine quadratische Form hat.

Verwenden Sie eine Wasserwaage, um sicherzustellen, dass der befestigte Sockel waagrecht steht.

**IT\_** Portare la base completamente assemblata nel luogo prescelto e fissarla al terreno.

**CONSIGLIO:** misurate la lunghezza delle due diagonali della base per assicurarvi che la base sia di forma quadrata.

Utilizzare una livella per assicurarsi che la base fissata sia a livello.

**EN** Two foundation options with pre-fabricated Base  
**FR** Deux options de fondation avec base préfabriquée  
**ES** Dos opciones de cimentación con base prefabricada  
**PT** Duas opções de fundação com base pré-fabricada  
**DE** Zwei Fundamentoptionen mit vorgefertigtem Sockel  
**IT** Due opzioni di fondazione con base prefabbricata

**EN** Option 1: Corner Stakes mounted into the soil  
**FR** Option 1: Piquets d'angle montés dans le sol  
**ES** Opción 1: Estacas de esquina instaladas en el suelo  
**PT** Opção 1: Estacas de canto montadas no solo  
**DE** Möglichkeit 1: In den Boden eingelassene Eckpfähle  
**IT** Opzione 1: Paletti angolari montati nel terreno

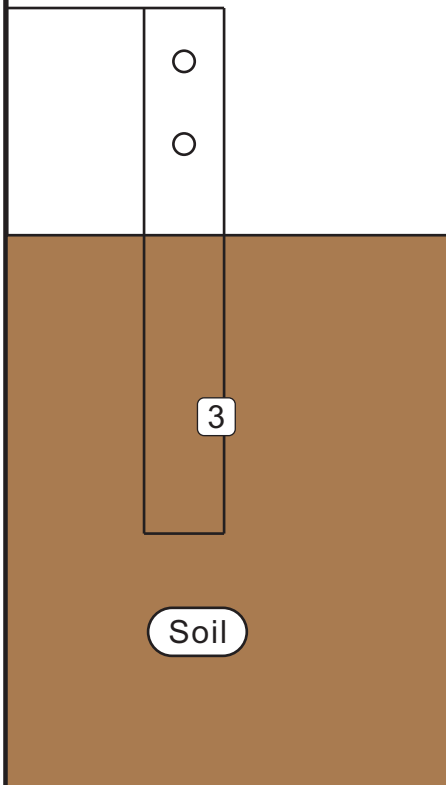

**EN** Easy and quick to install. Suitable to use in areas with less extreme weather  
**FR** Facile et rapide à installer. Convient aux régions où les conditions météorologiques sont moins extrêmes.  
**ES** Fácil y rápido de instalar. Adecuado para su uso en zonas con climas menos extremos  
**PT** Fácil e rápido de instalar. Adequado para utilização em zonas com condições climatéricas menos extremas  
**DE** Einfach und schnell zu installieren. Geeignet für den Einsatz in Gebieten mit weniger extremen Wetterbedingungen  
**IT** Facile e veloce da installare. Adatto all'uso in aree con clima meno estremo

**EN** Option 2: Corner Stakes mounted into concrete  
**FR** Option 2: Piquets d'angle montés dans le béton  
**ES** Opción 2: Estacas de esquina montadas en hormigón  
**PT** Opção 2: Estacas de canto montadas em betão  
**DE** Möglichkeit 2: In Beton montierte Eckpfähle  
**IT** Opzione 2: Paletti d'angolo montati nel calcestruzzo

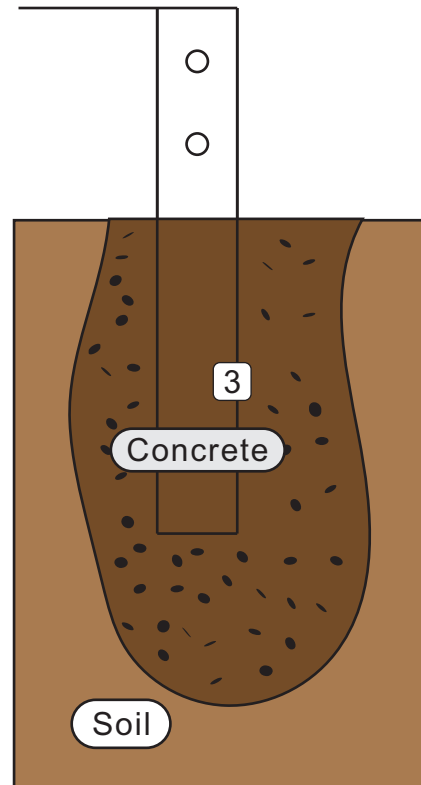

**EN** Best option if you want your greenhouse fully secured.  
**FR** La meilleure option si vous souhaitez que votre serre soit entièrement sécurisée.  
**ES** La mejor opción si desea que su invernadero esté totalmente protegido.  
**PT** A melhor opção se quiser que a sua estufa fique totalmente protegida.  
**DE** Die beste Option, wenn Sie Ihr Gewächshaus vollständig sichern wollen.  
**IT** L'opzione migliore se volete che la vostra serra sia completamente protetta.

# Assembling of Door

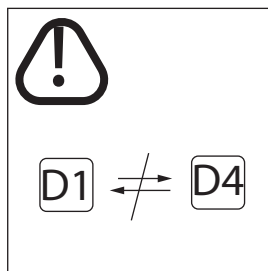
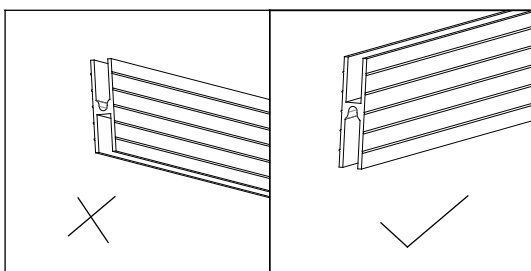
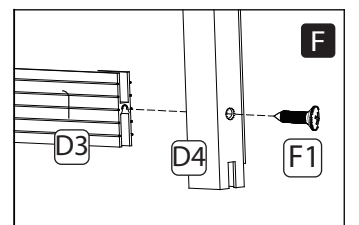
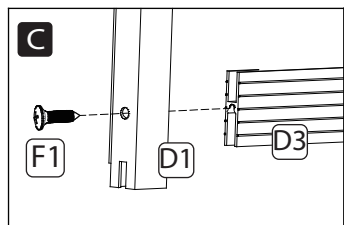
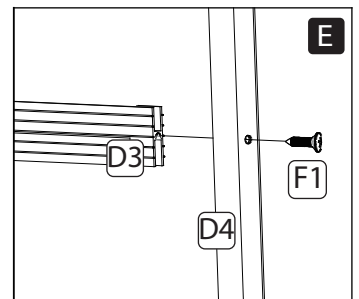
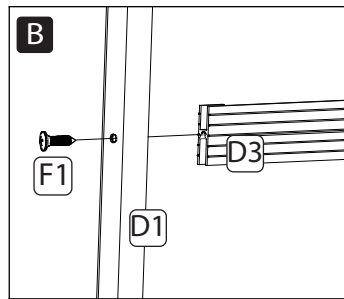
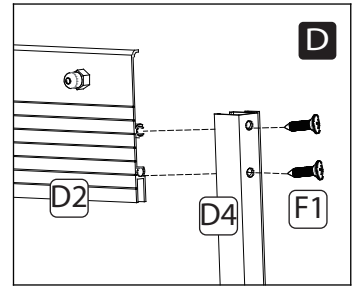
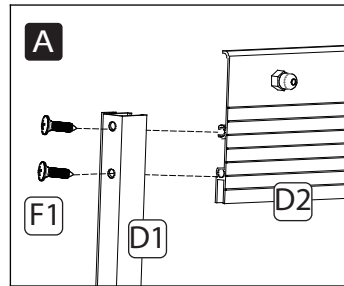
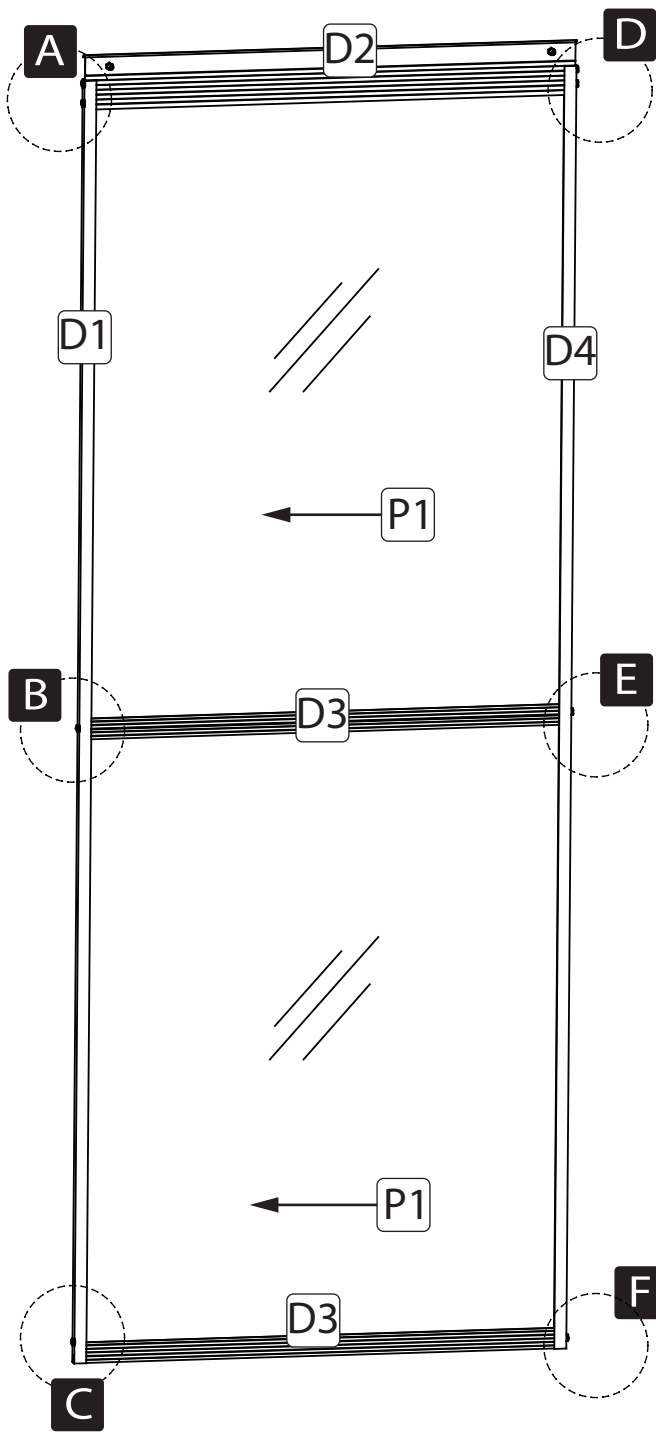

Part No.	Part	Qty.
D1		1
D2		1
D3		2
D4		1
F1		8
P1		2

# Assembling of window

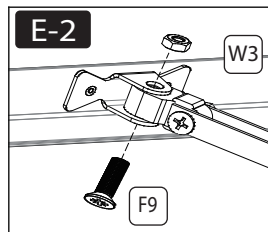
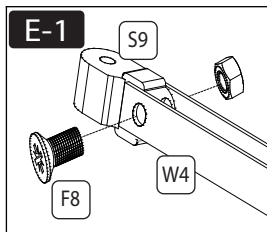
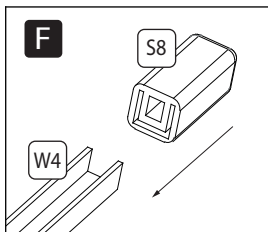
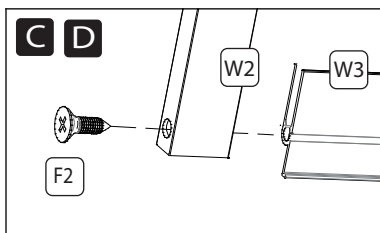
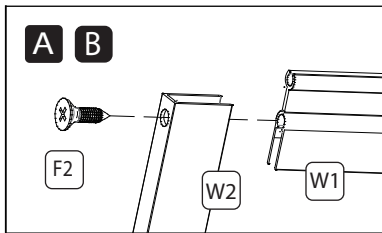
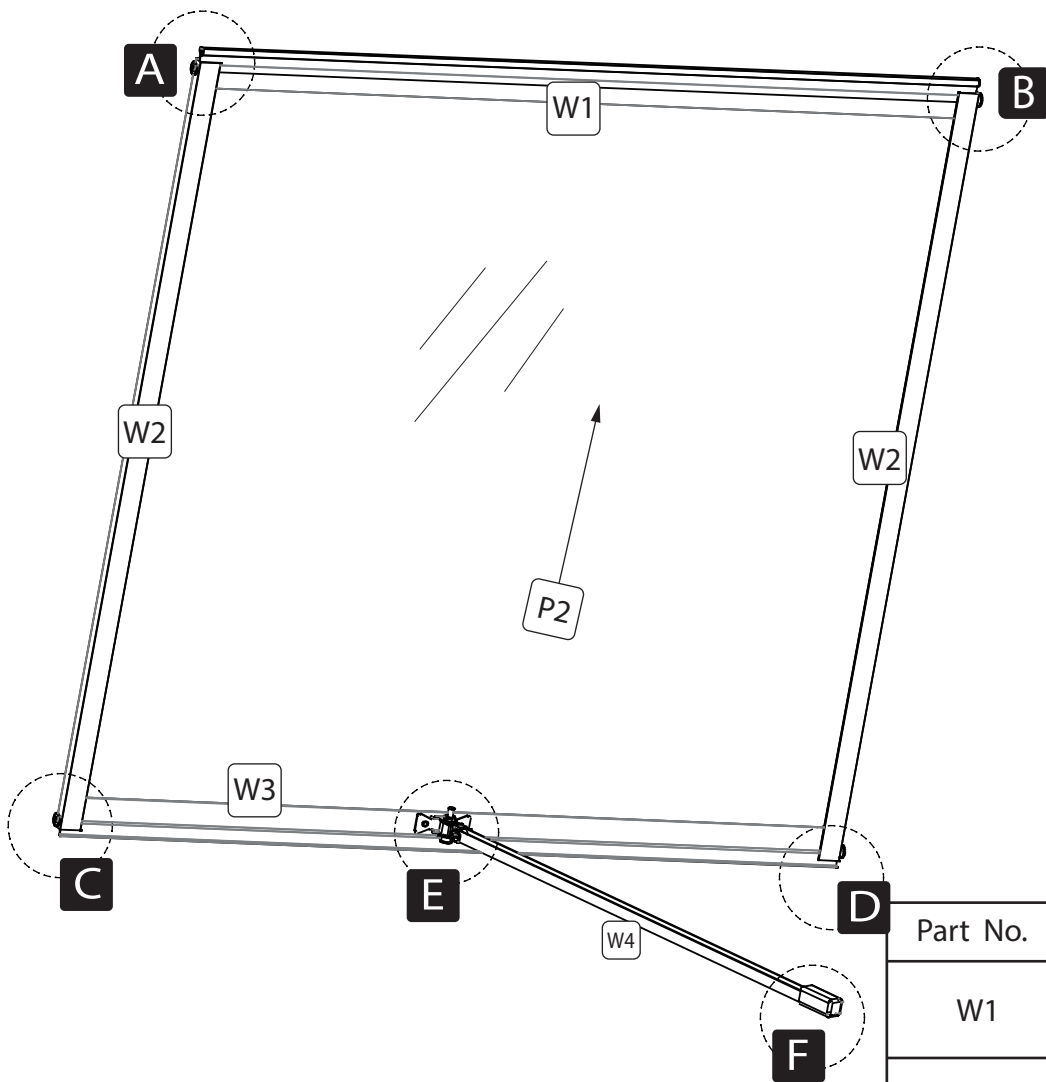

Part No.	Part	Qty.
W1		1
W2		2
W3		1
W4		1
S8		1
S9		1
F2		4
F8		1
F9		1
P2		1

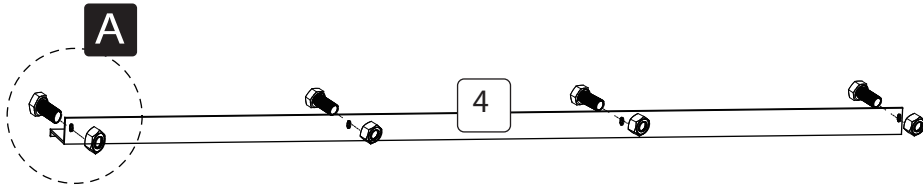

2X

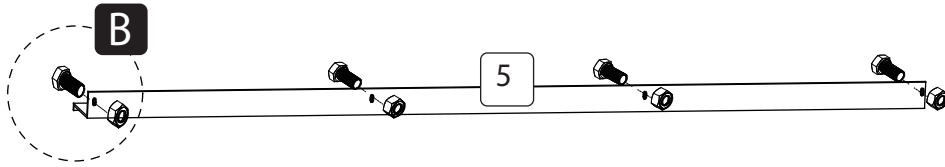

1X

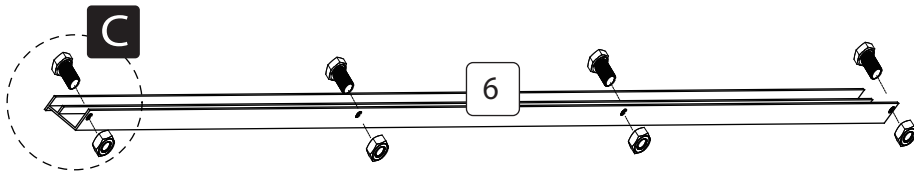

1X

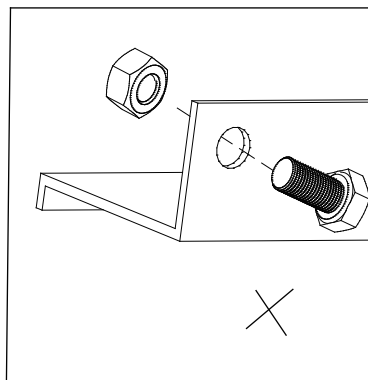
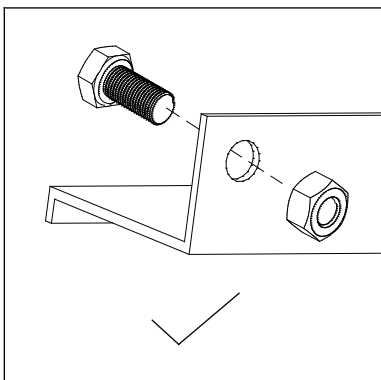
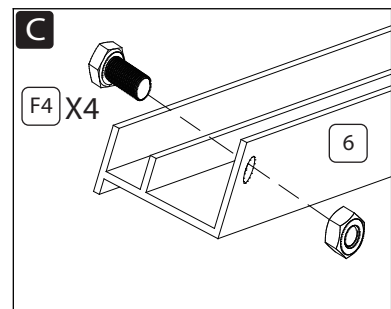
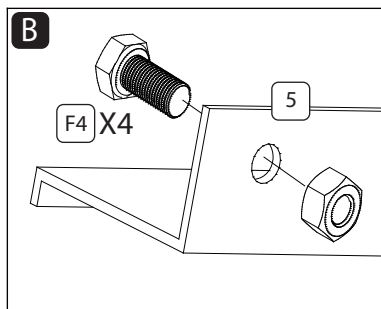
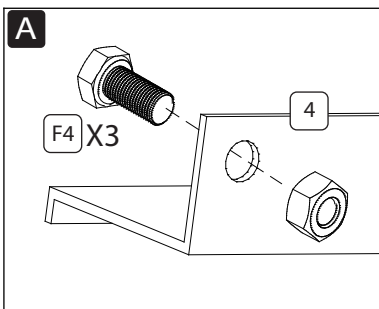
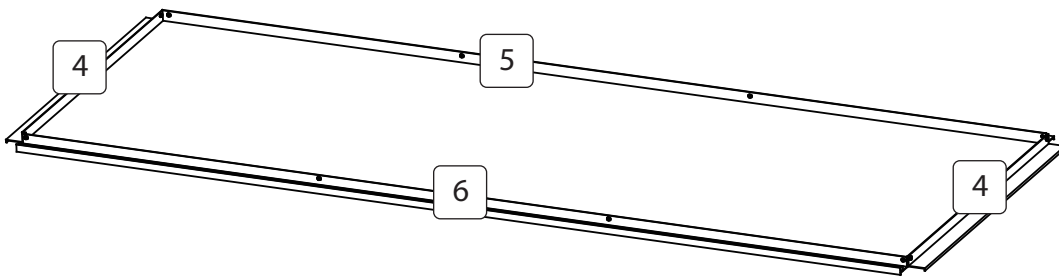

Part No.	Part	Qty.
4		2
5		1
6		1
F4		16

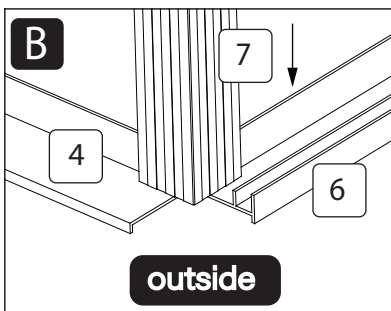
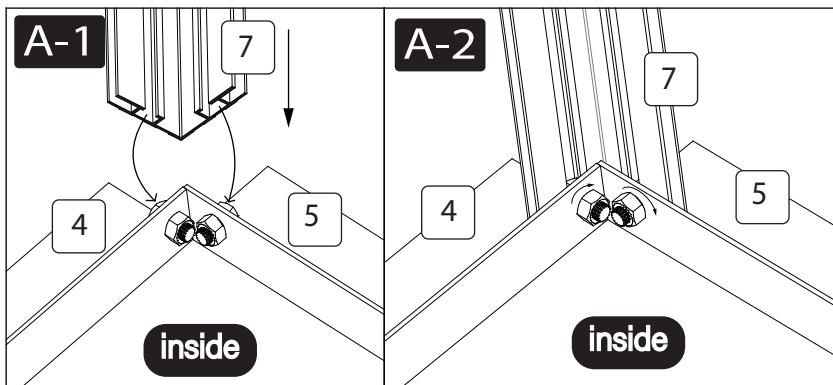
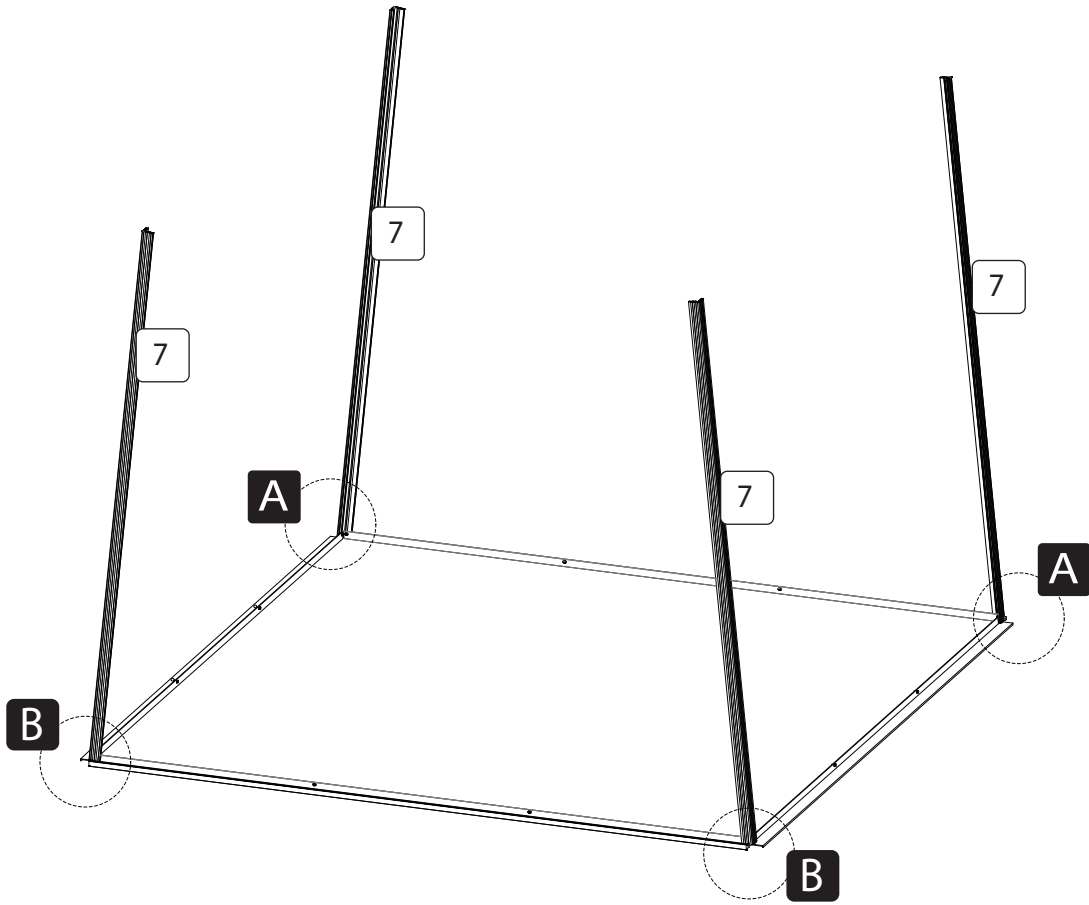

Part No.	Part	Qty.
7		4

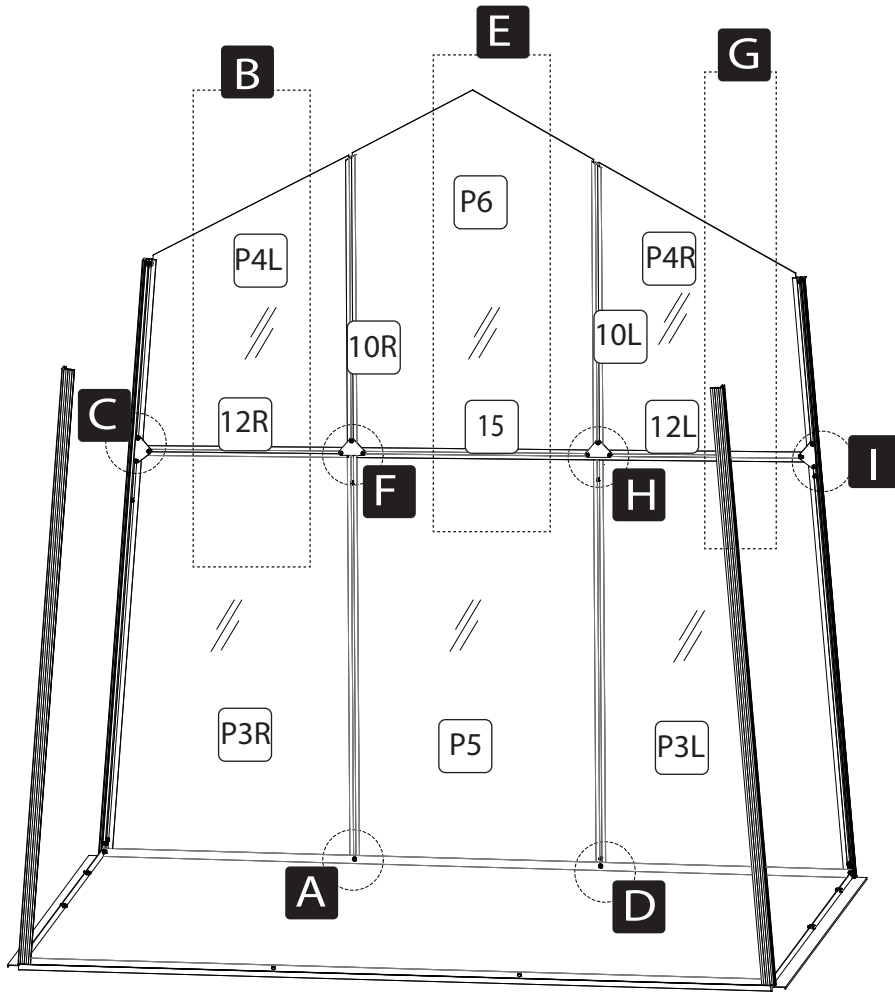

Part No.	Part	Qty.	Part No.	Part	Qty.
12R		1	P3R		1
12L		1	P3L		1
15		1	P5		1
10R		1	P4L		1
10L		1	P4R		1
F4		22	P6		1
			B15		4



inside

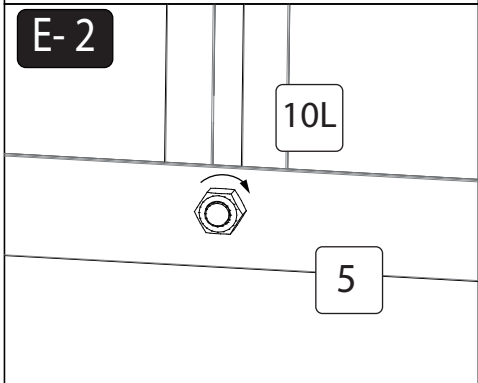
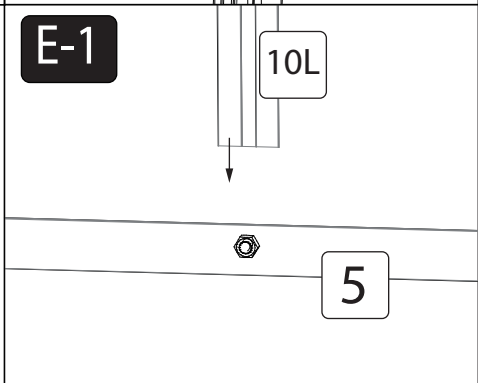
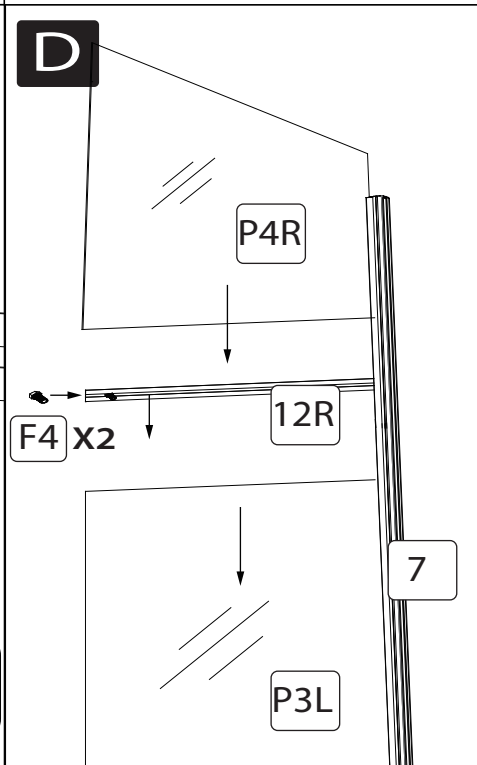
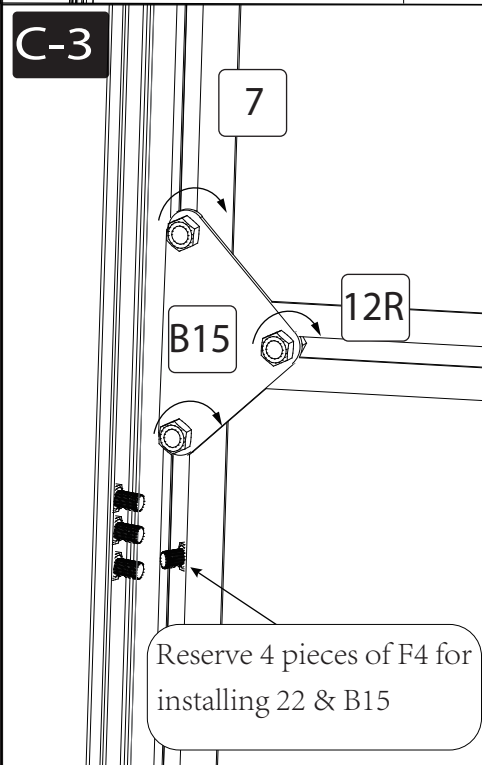
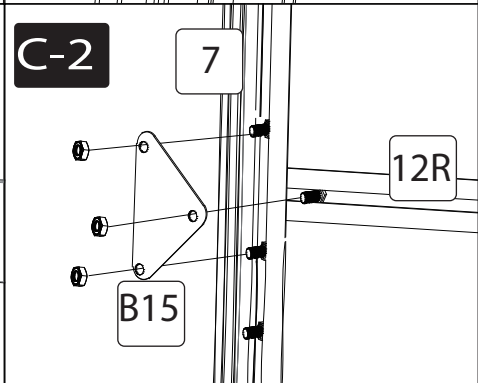
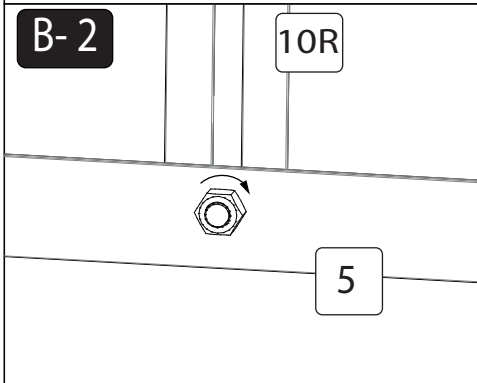
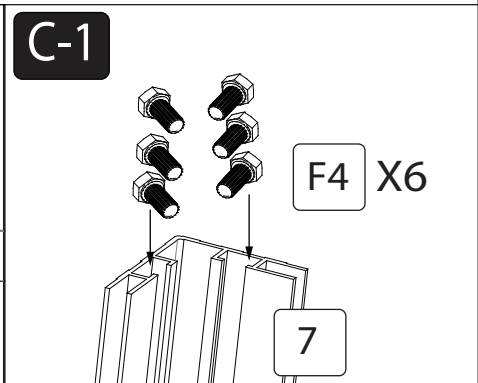
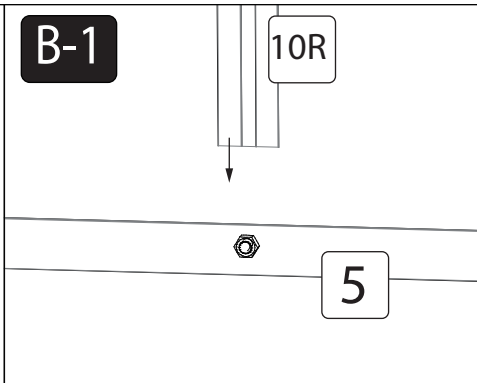
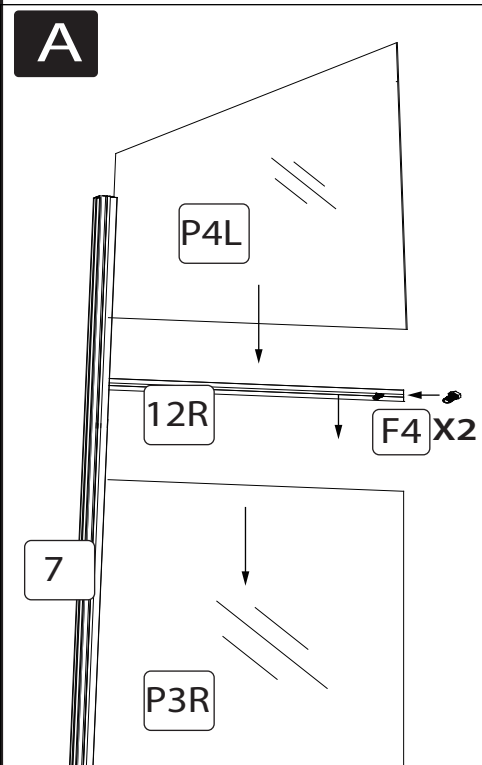

inside

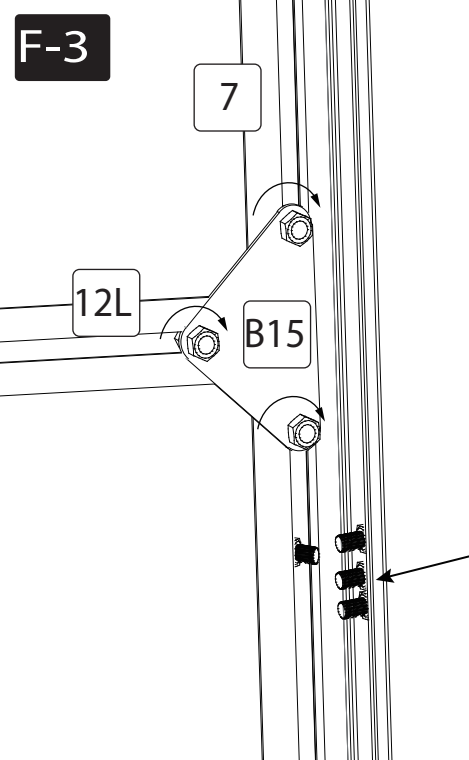
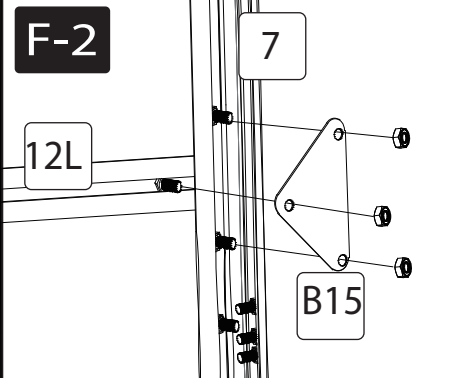
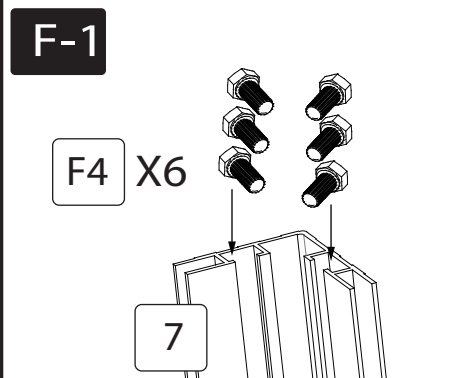

Reserve 4 pieces of F4 for installing 22 & B15

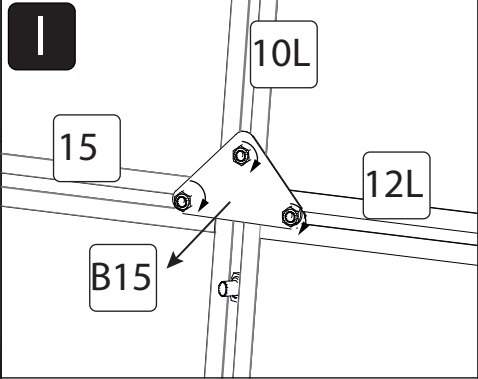
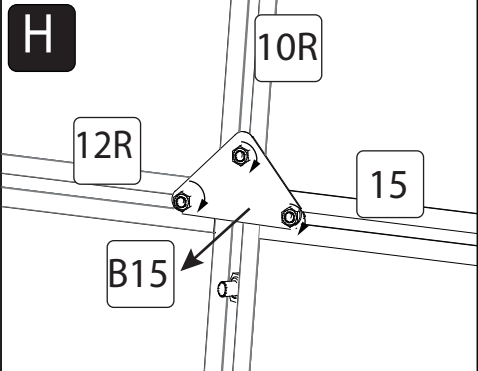
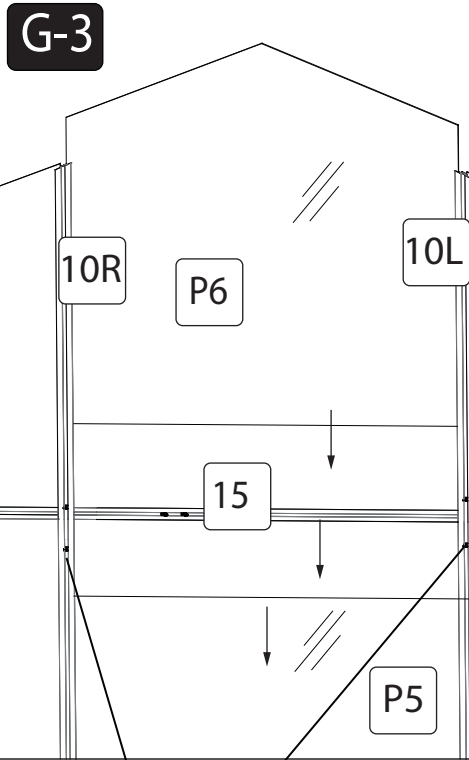
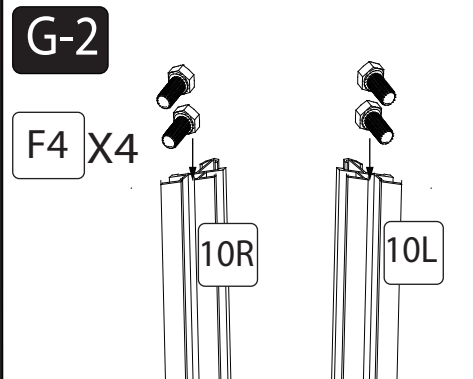
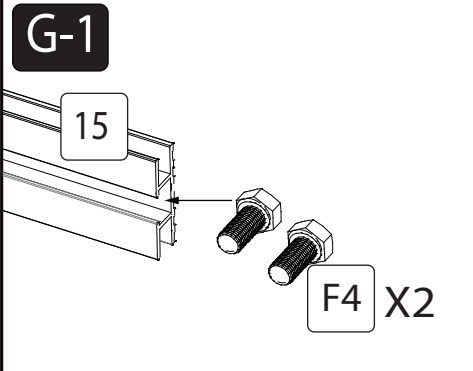

one extra bolt F4 for part 22

inside

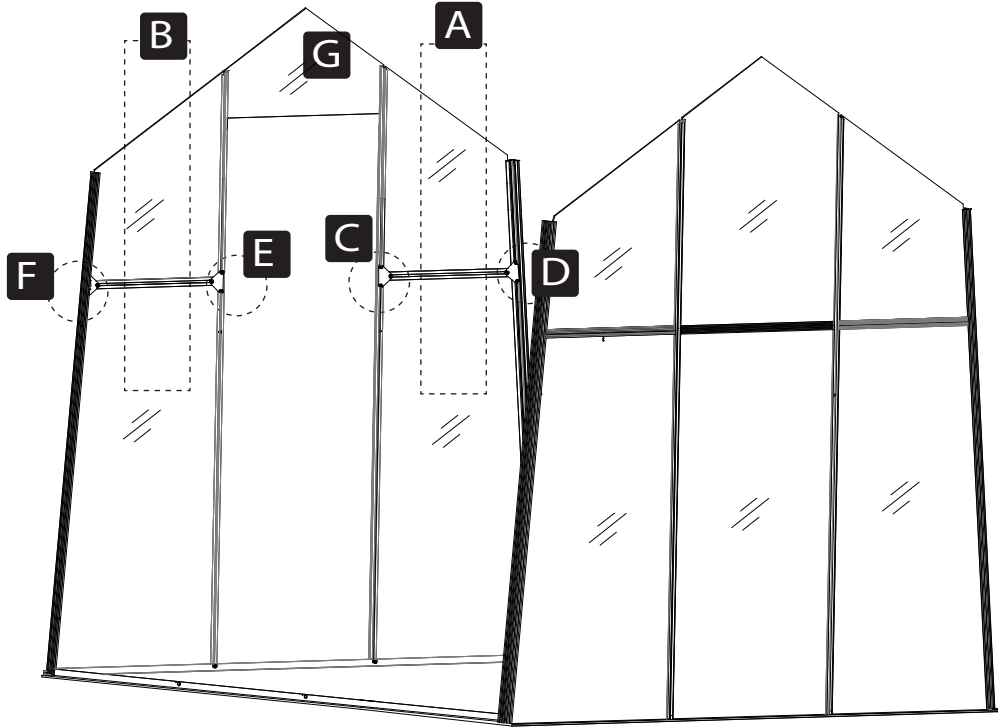

outside

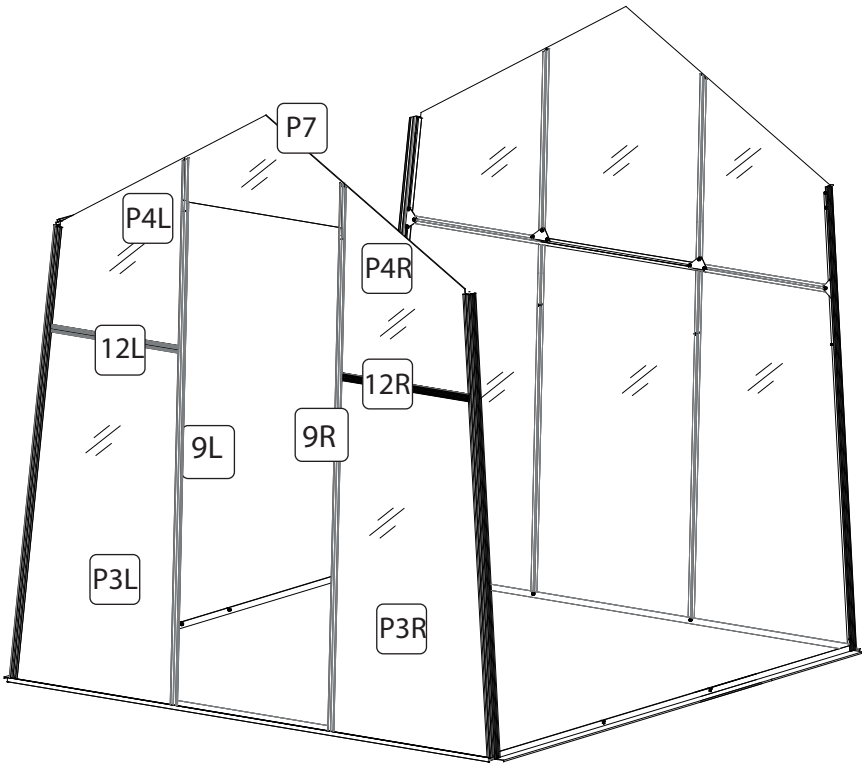

Part No.	Part	Qty.
P3R		1
P3L		1
P4L		1
P4R		1
P7		1
12R		1
12L		1
9R		1
9L		1
B15		4
F4		26

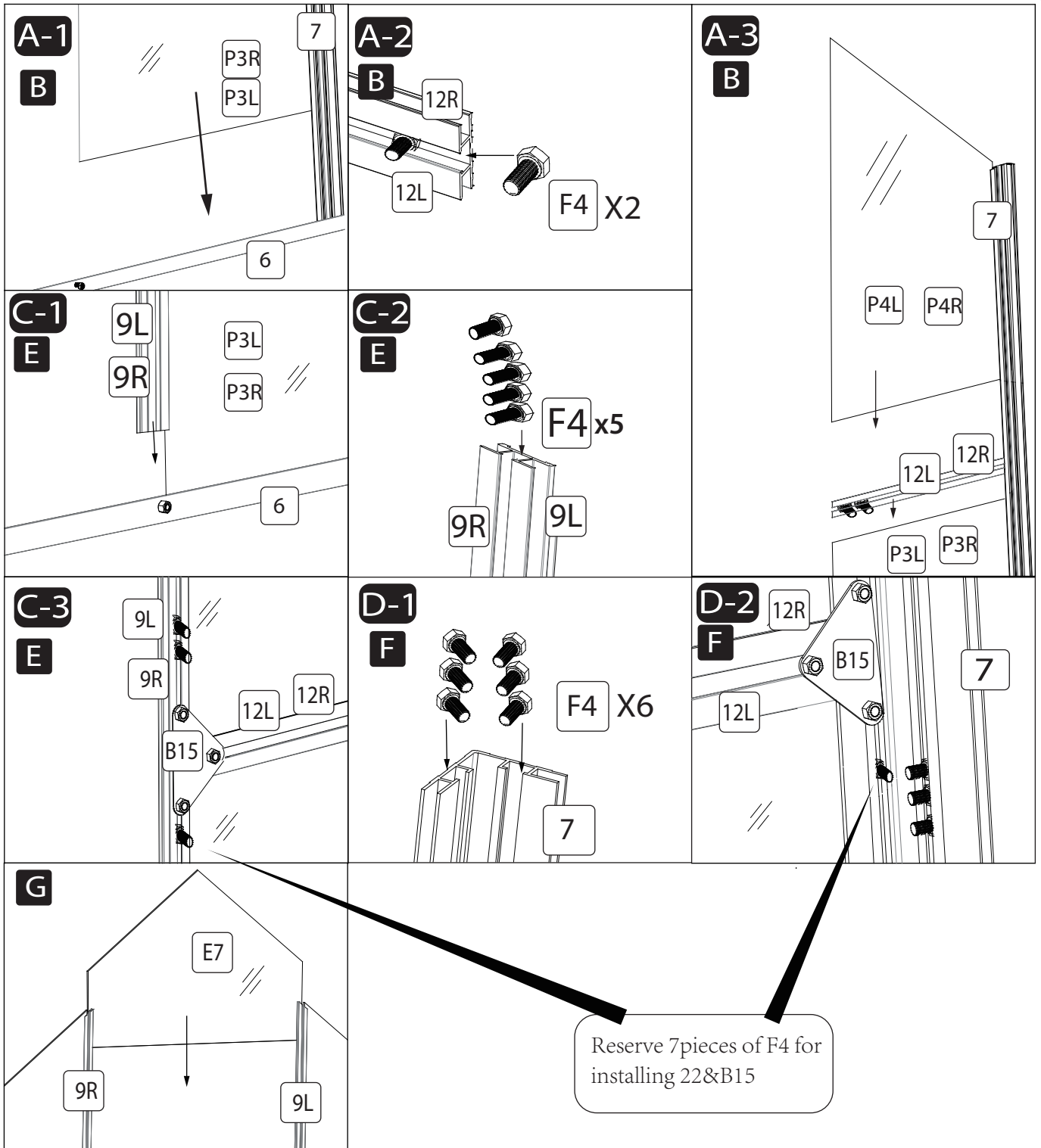

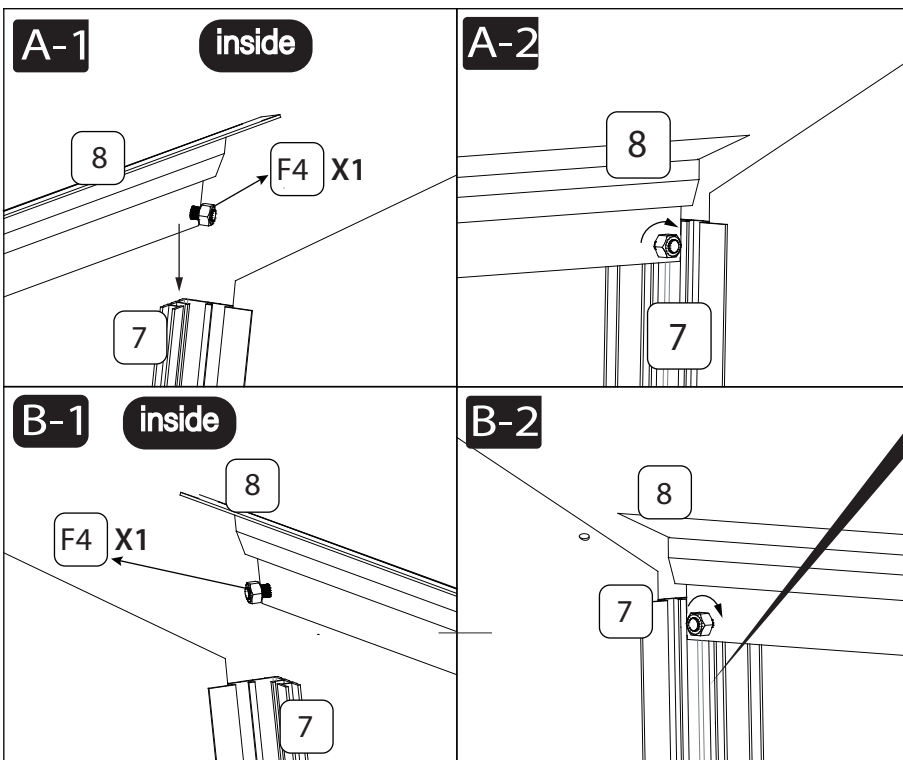
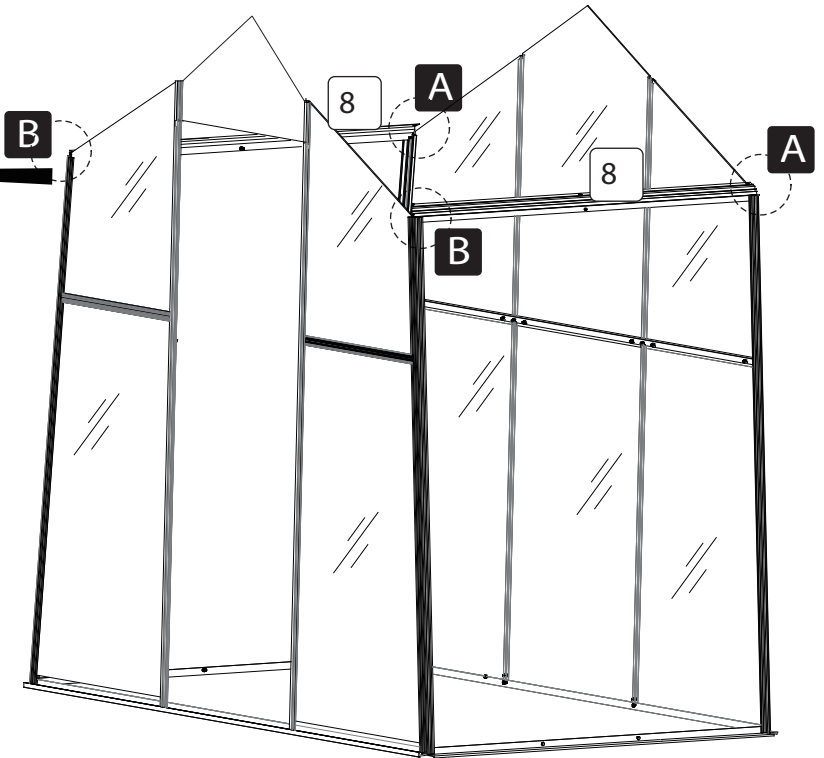
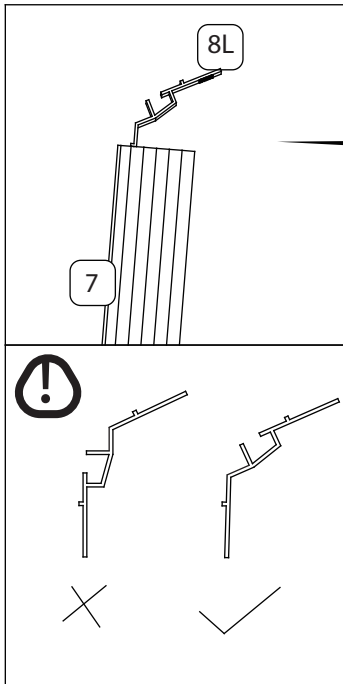

Reserve 6 pieces of F4 for installing 22 & B15

Part No.	Part	Qty.
8		2
F4		4

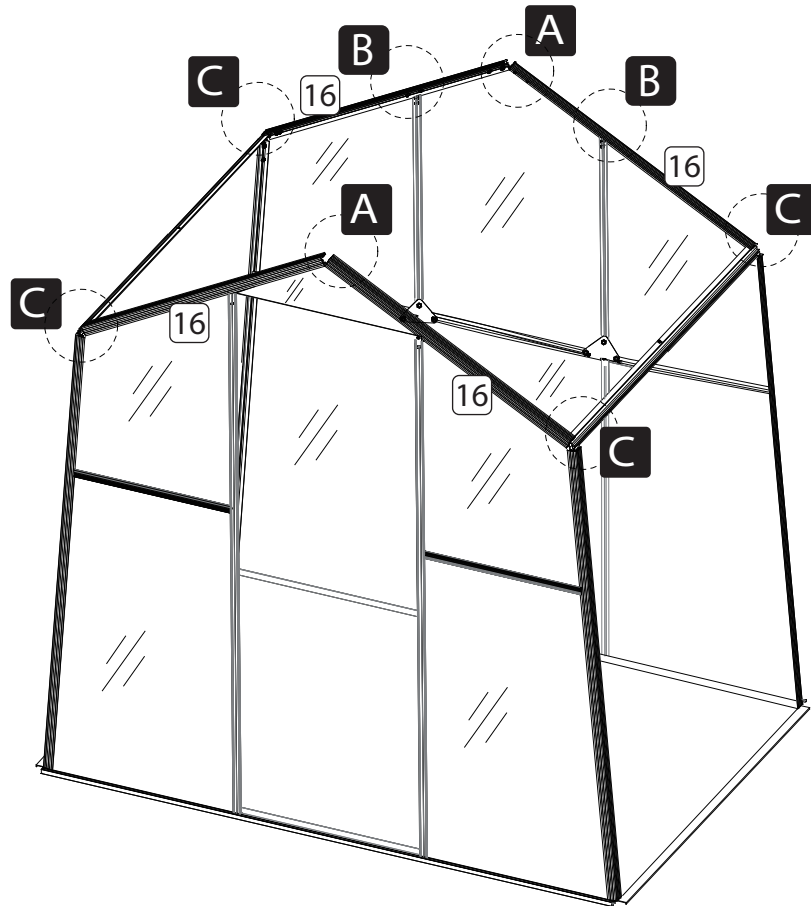

**inside**

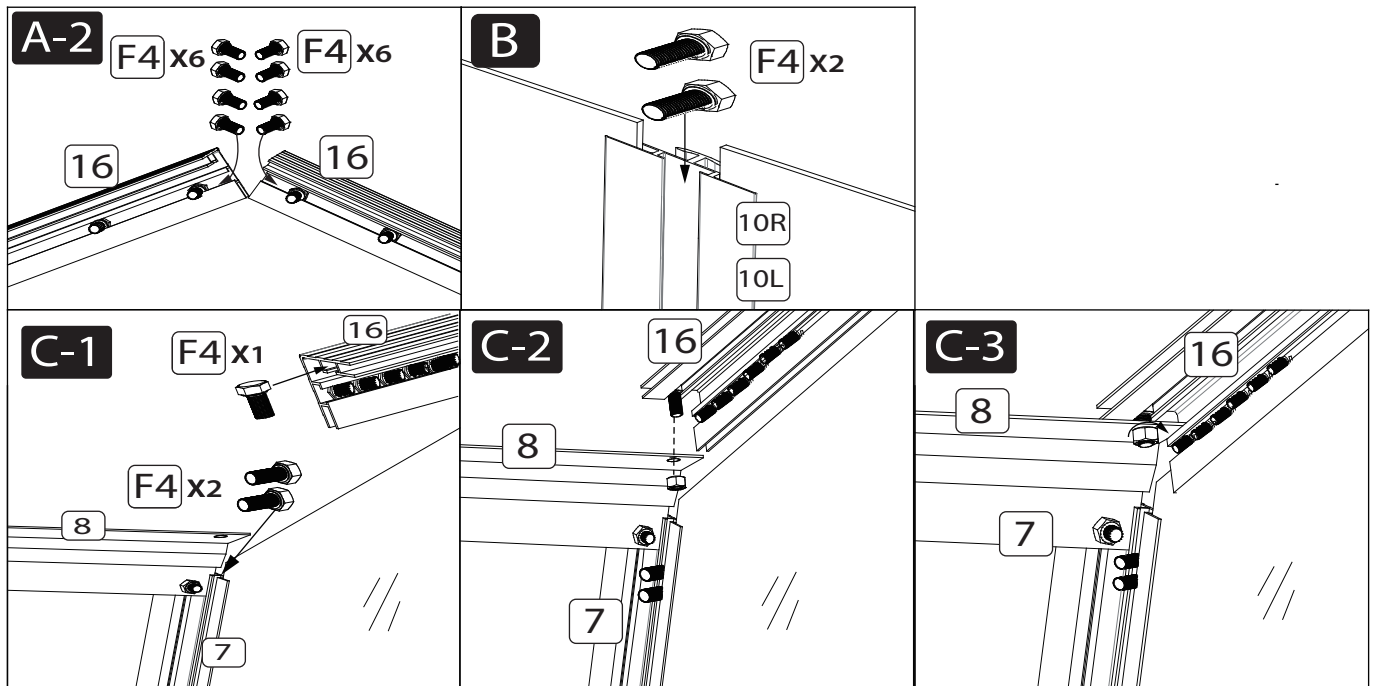

Reserve 36 pieces of F4 for installing B4 B5 B6

Part No.	Part	Qty.
16		4
F4		40

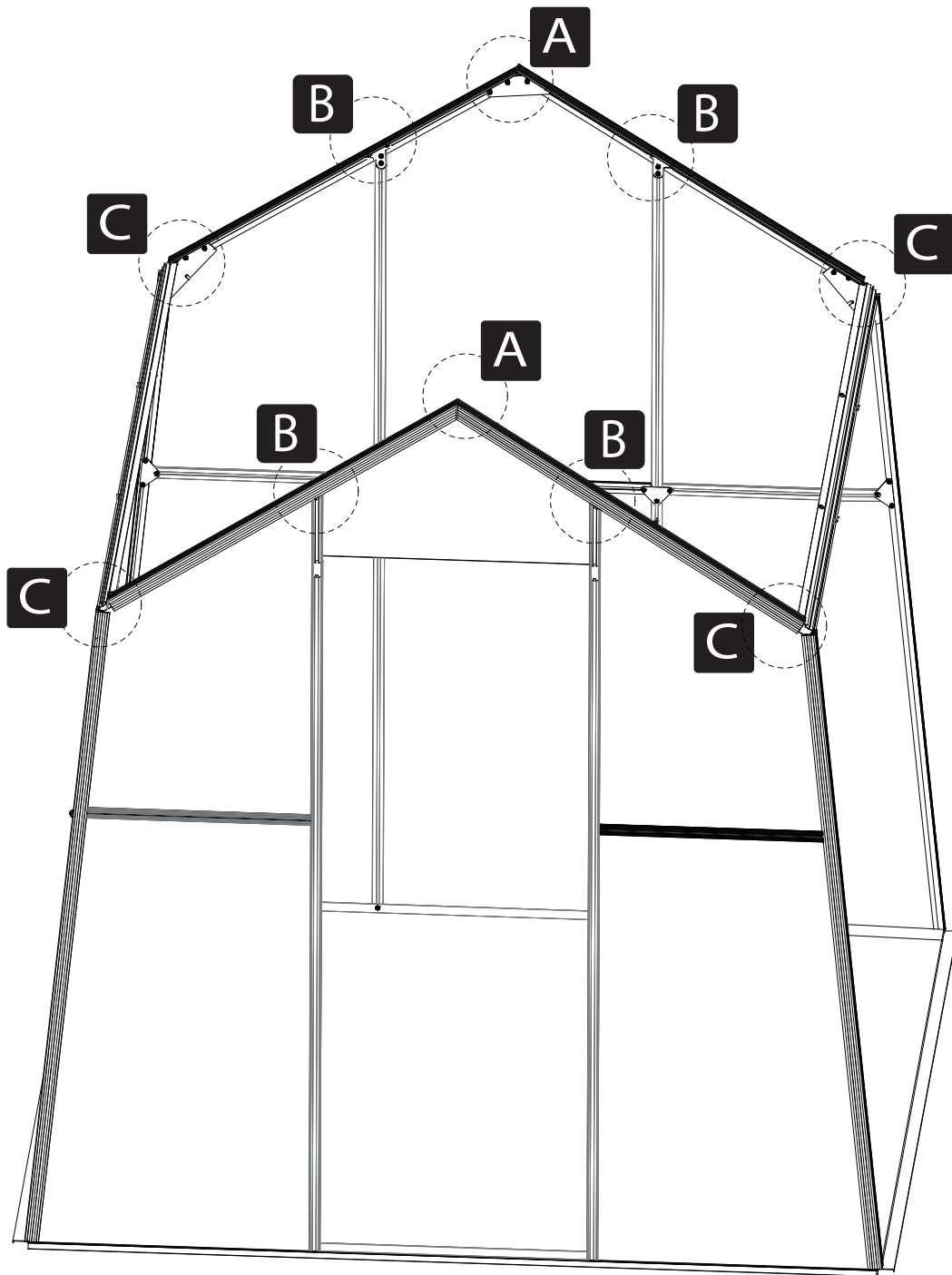

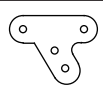
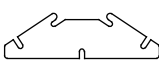
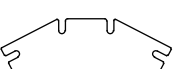
Part No.	Part	Qty.
B4		4
B5		4
B6		2

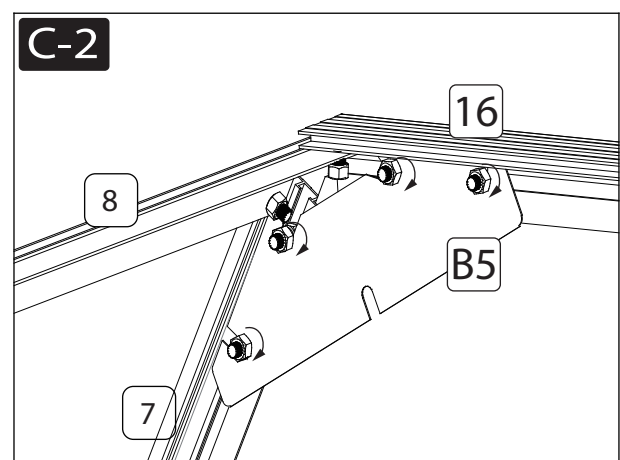
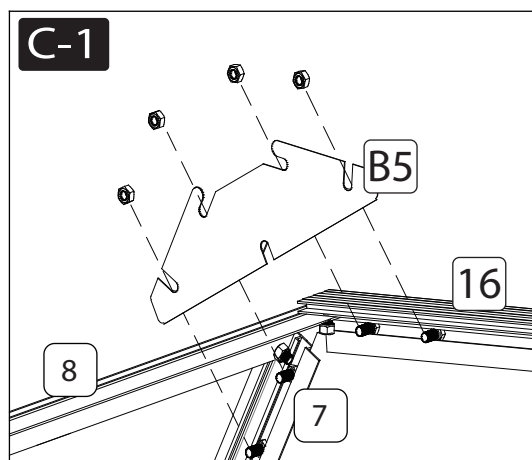
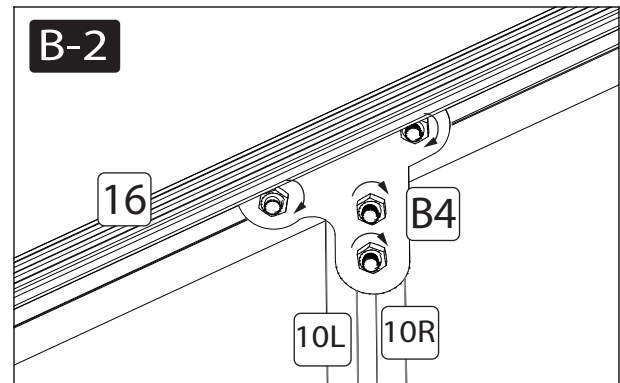
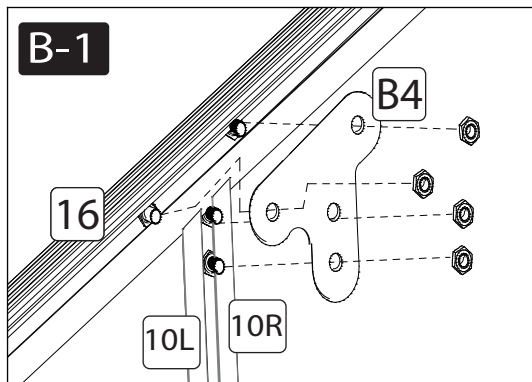
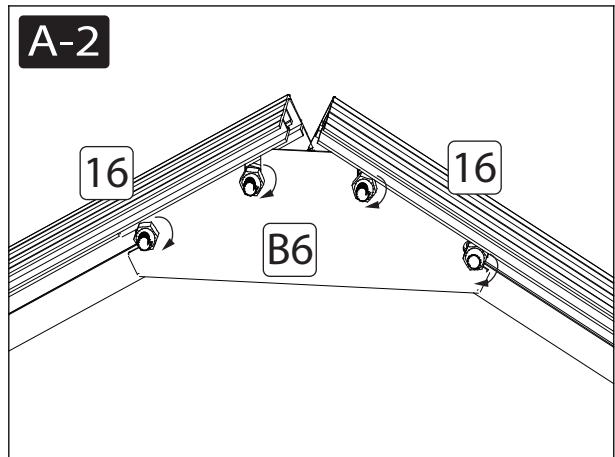
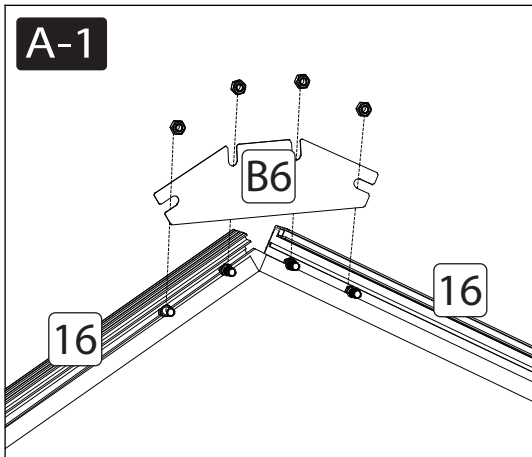

tighten the nuts on B4, B5 and B6 after adjustment of the greenhouse



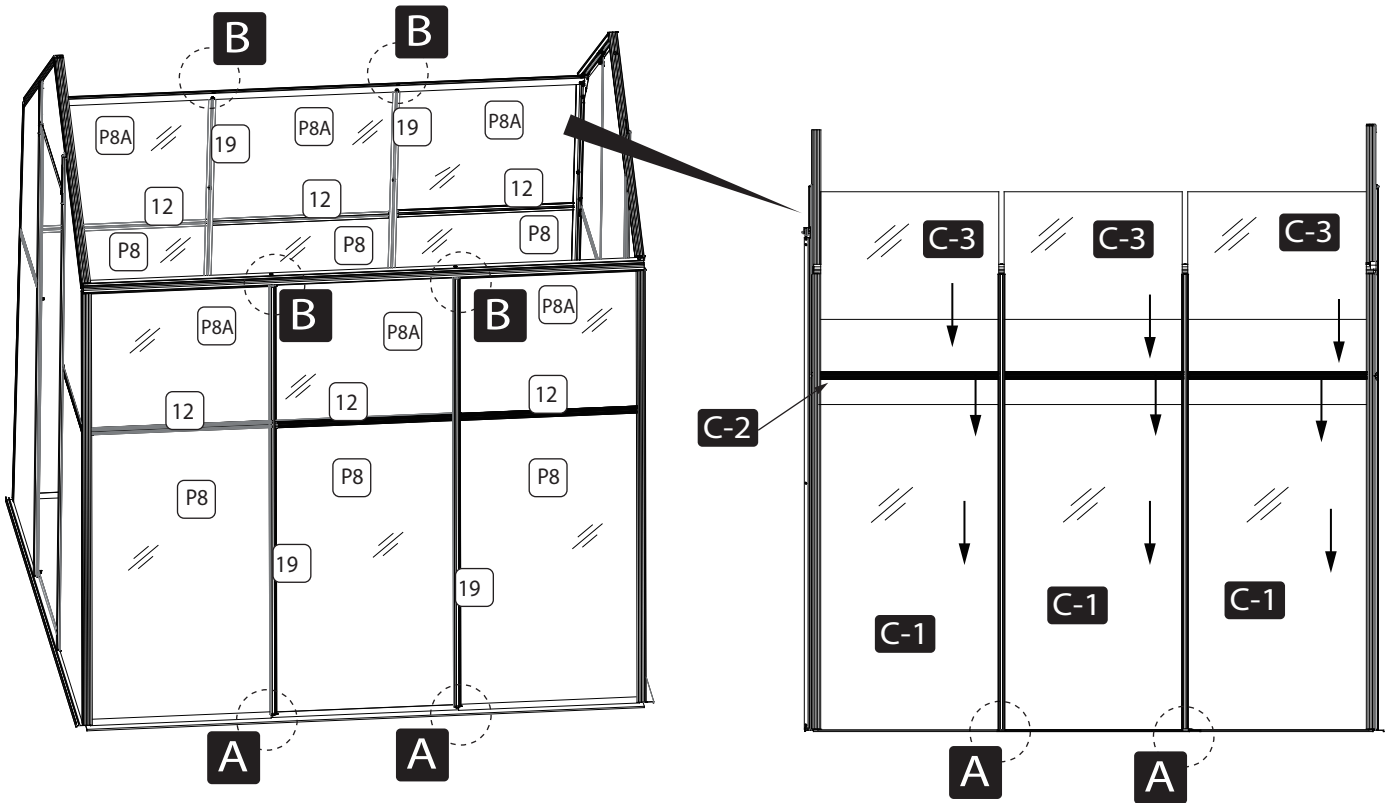

**inside**

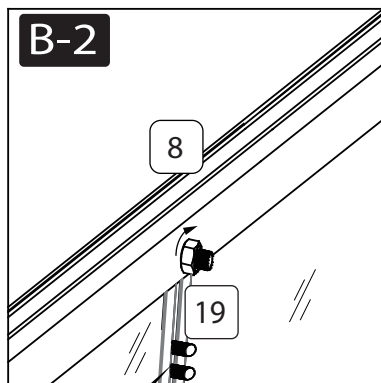
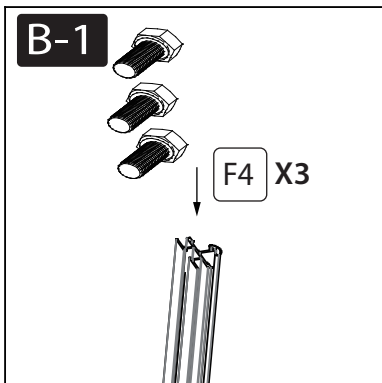
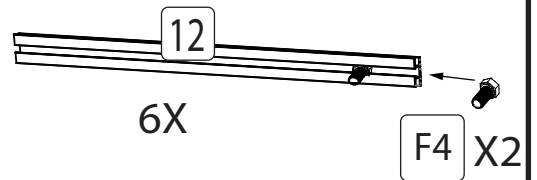
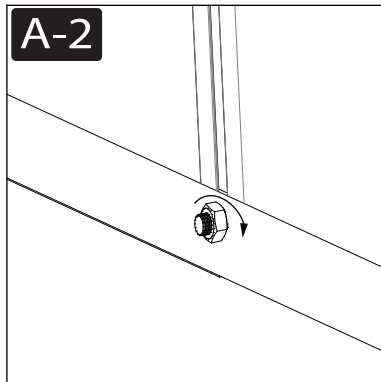
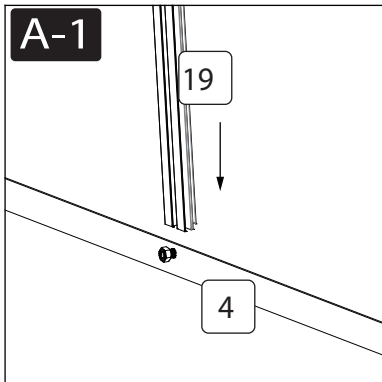

Reserve 2 pieces of F4 for installing 22 & B15



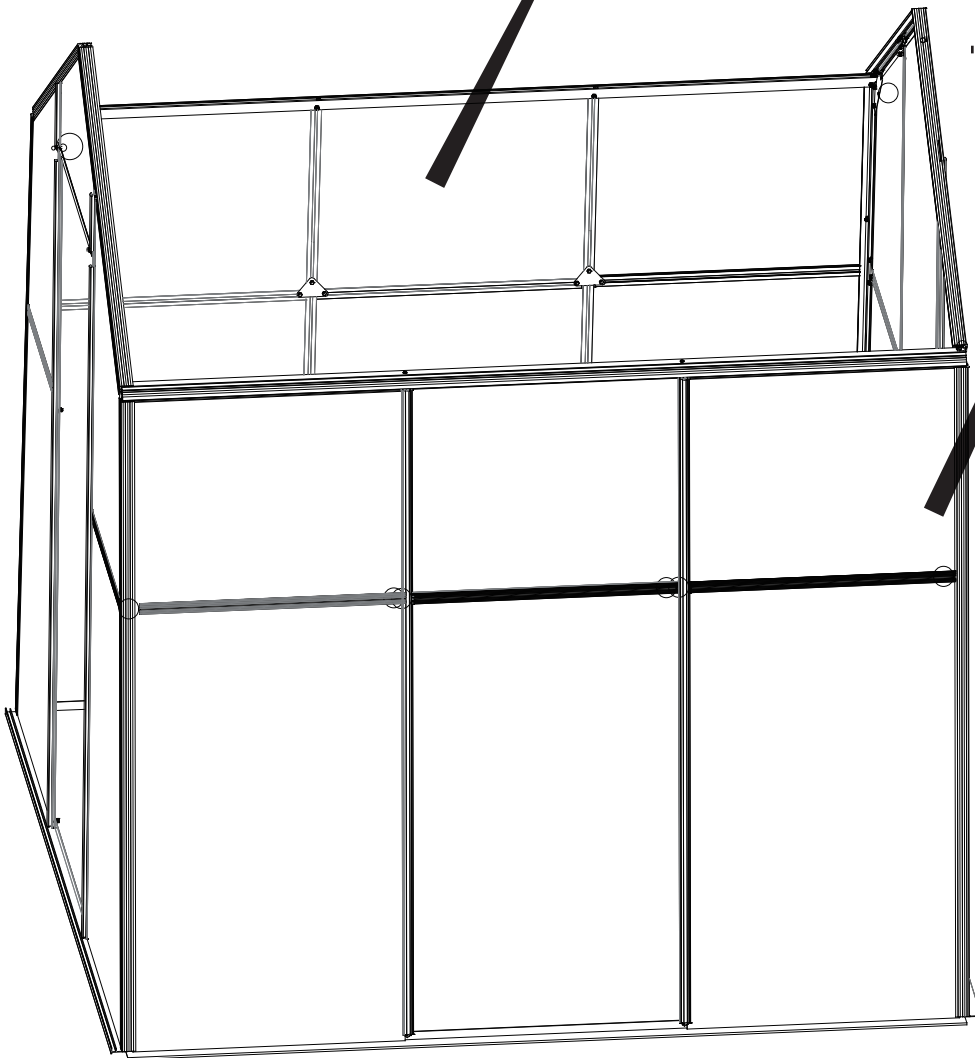
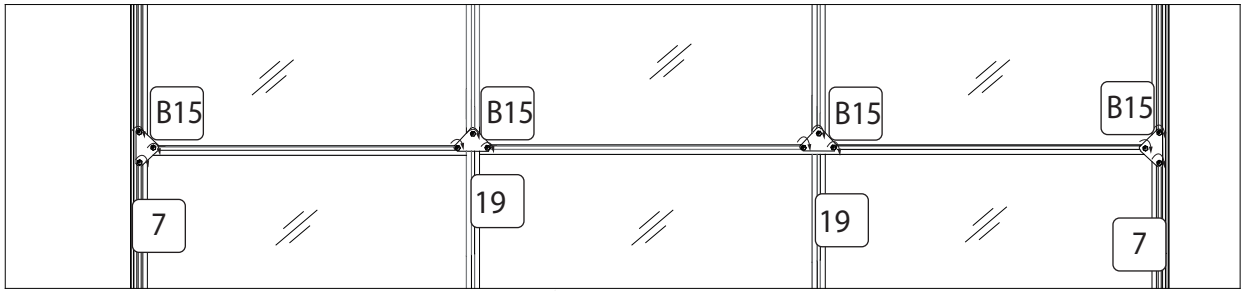



Part No.	Part	Qty.
P8		6
P8A		6
19		4
12		6
F4		24

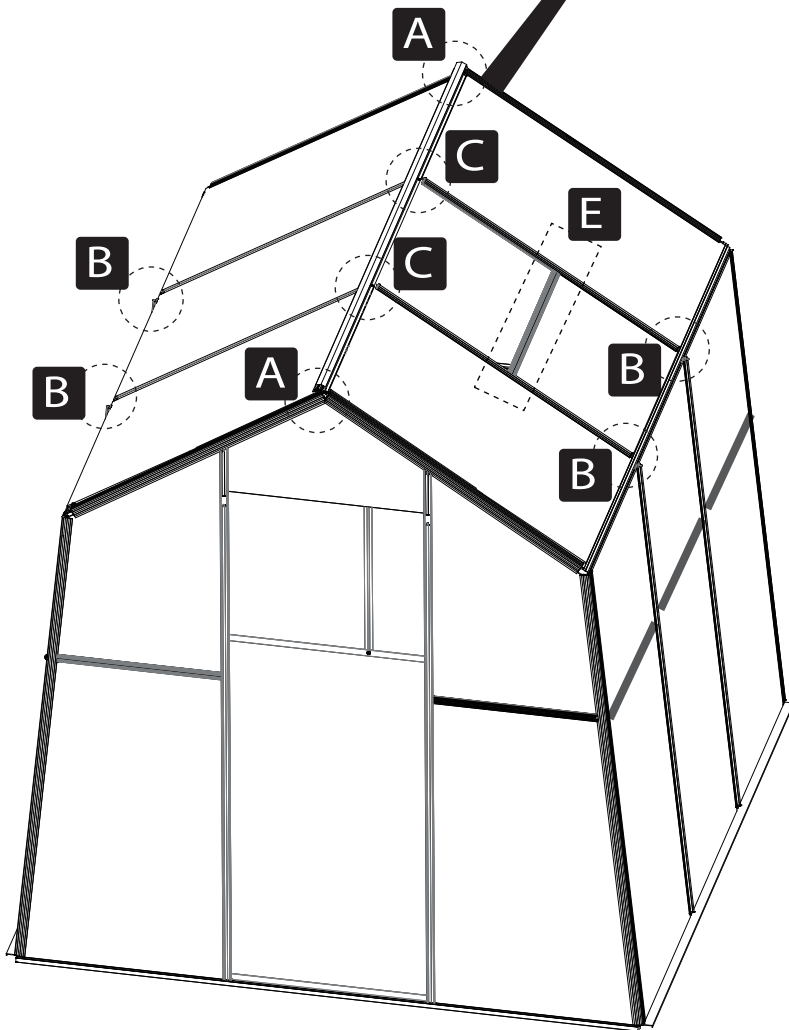
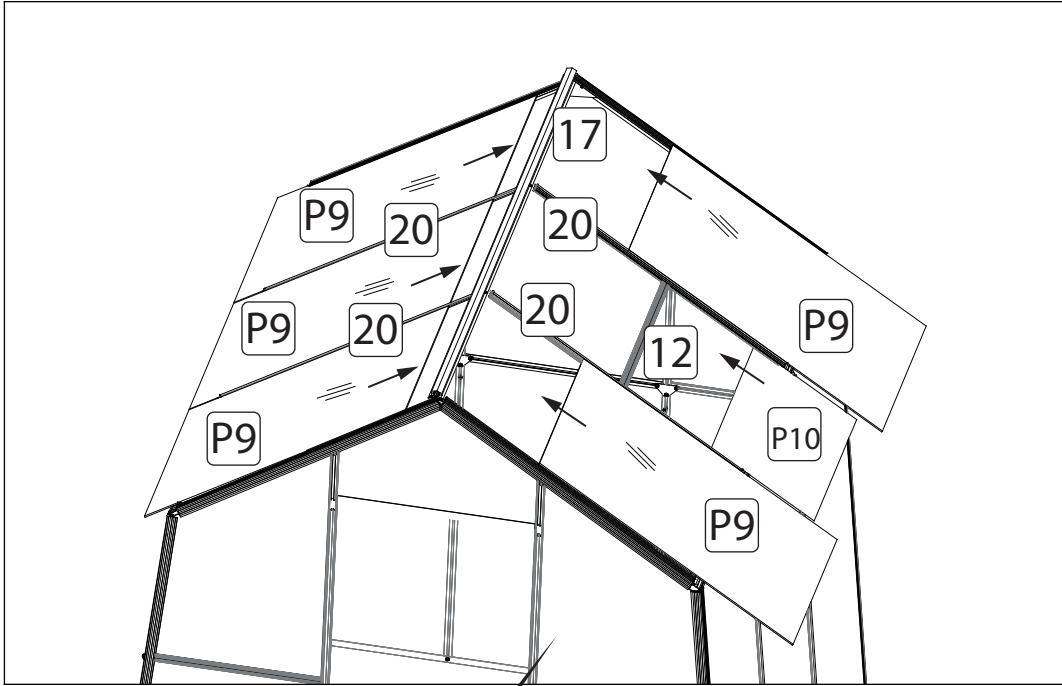

tighten the nuts on B15  
after adjustment of the greenhouse

Part No.	Part	Qty.
B15		8



Part No.	Part	Qty.
17		1
20		4
12		1
P9		5
P10		1
B15		2
F4		20

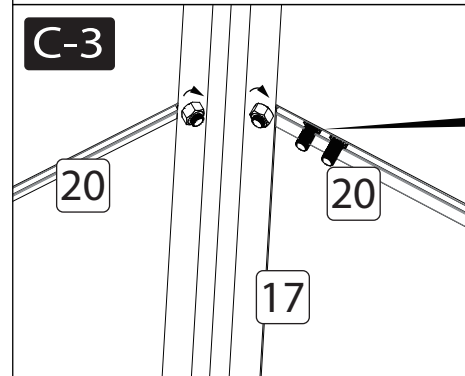
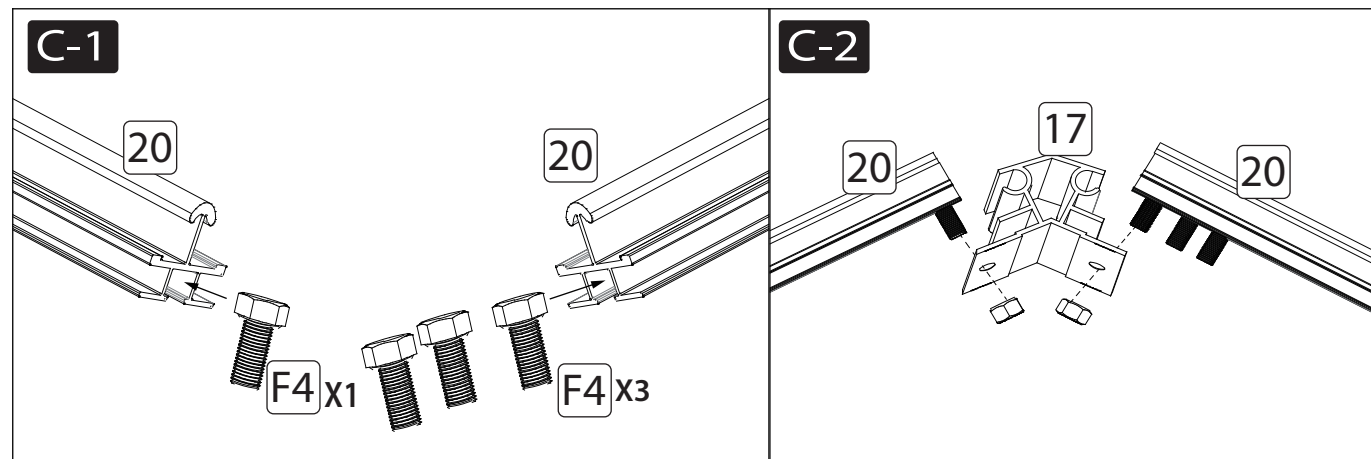
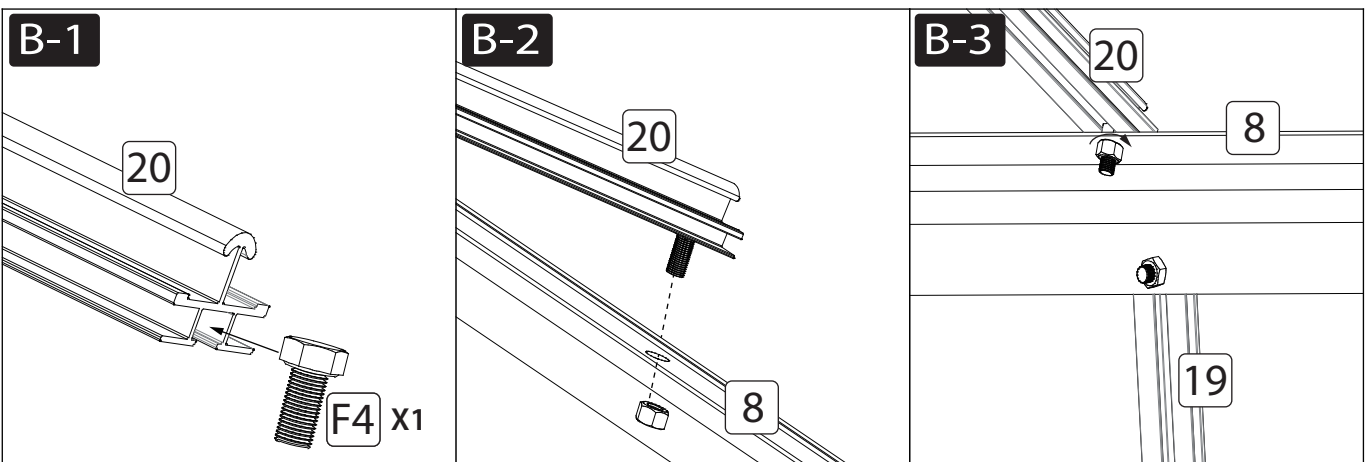
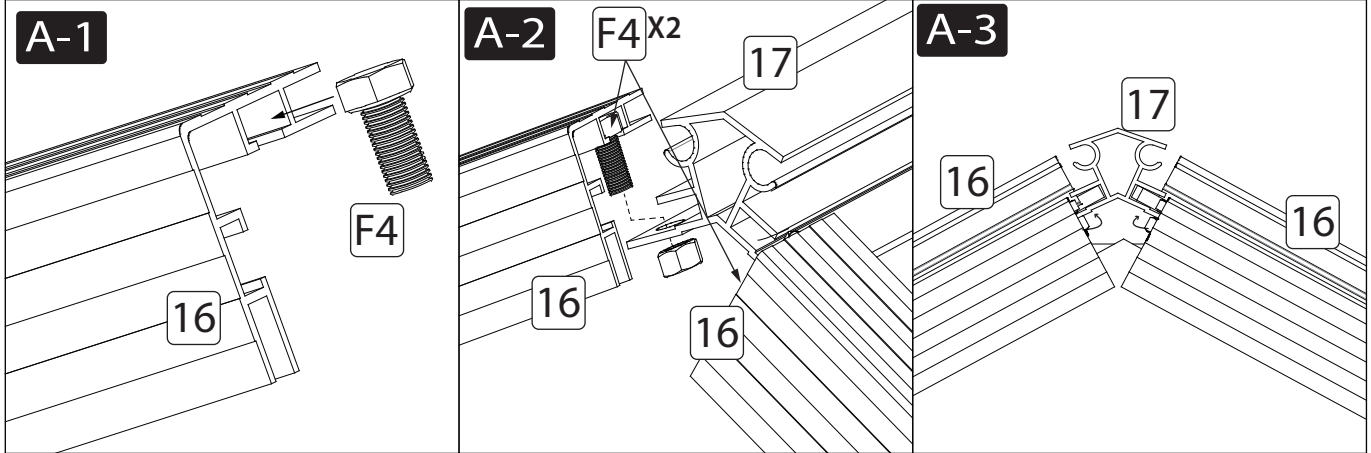

Reserve 2 pieces of F4 for installing B15

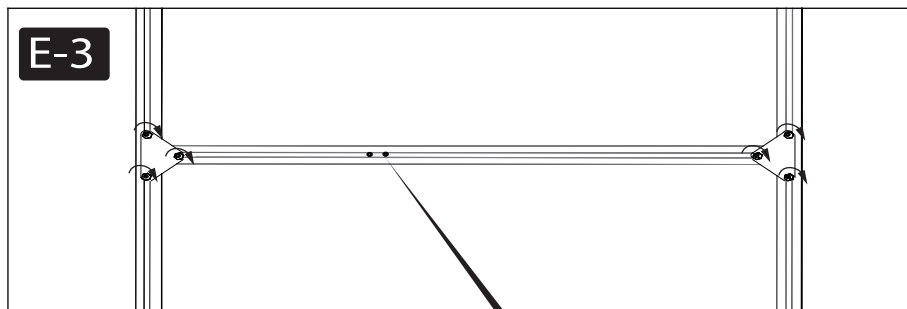
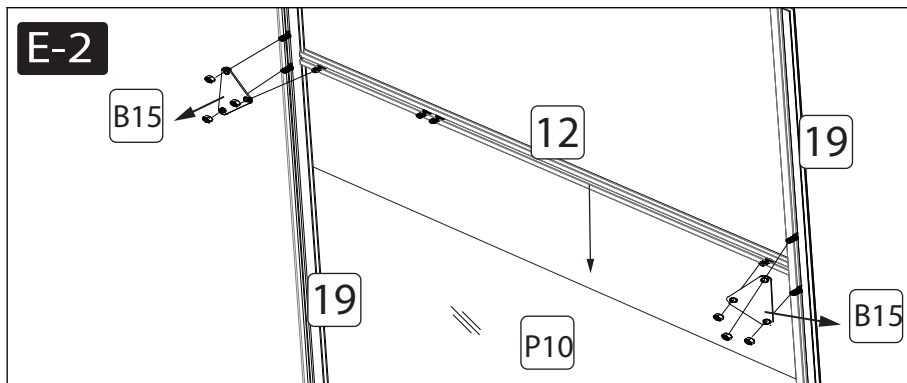
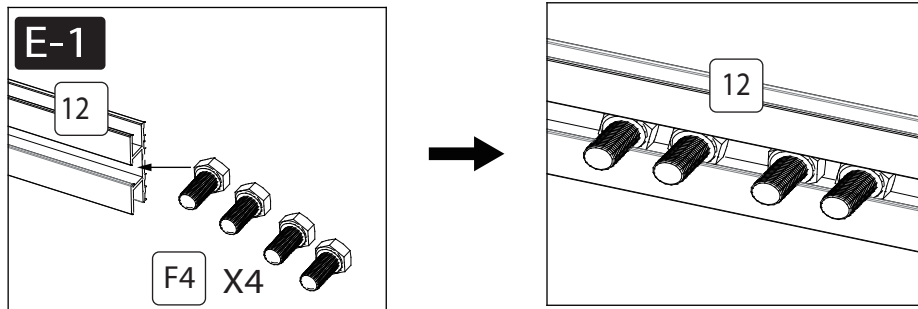

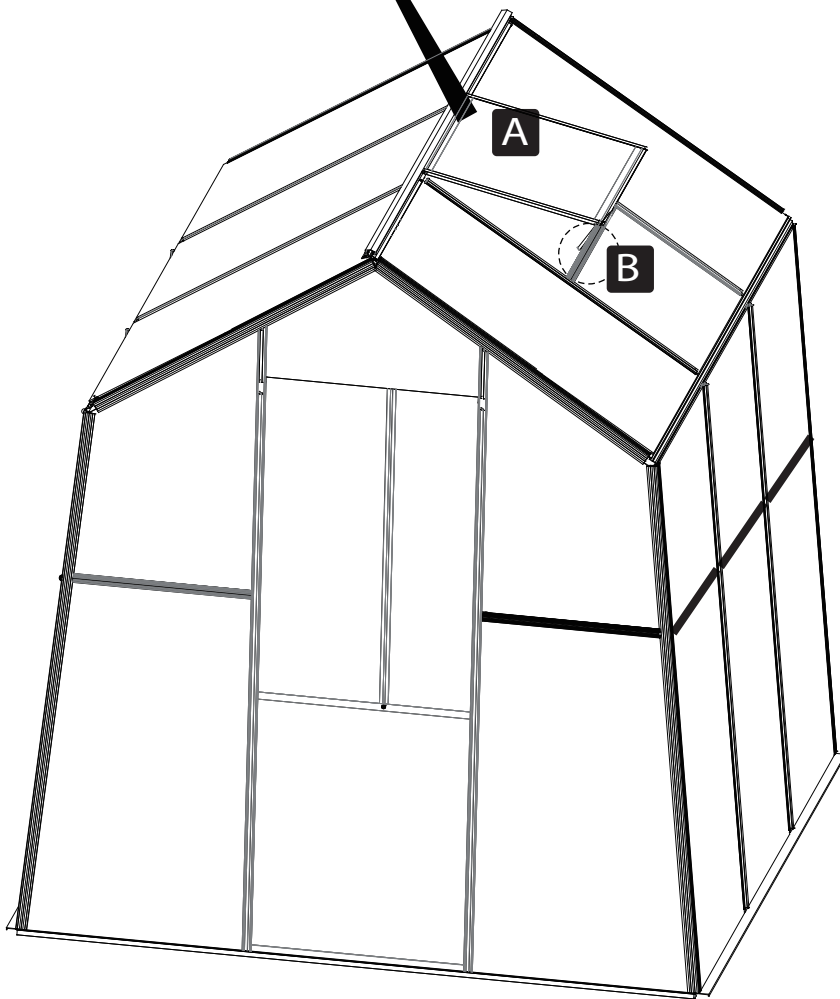
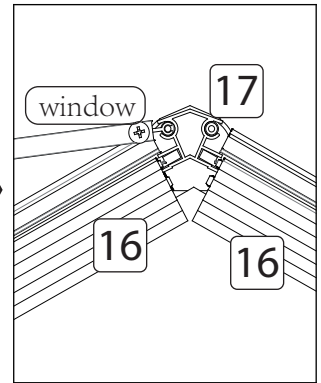
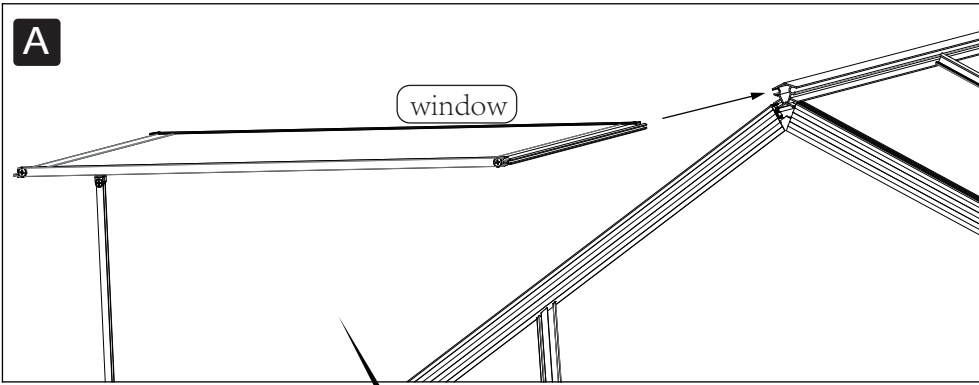

tighten the nuts on B15 after adjustment of the greenhouse

Reserve 2 pieces of F4 for installing B7

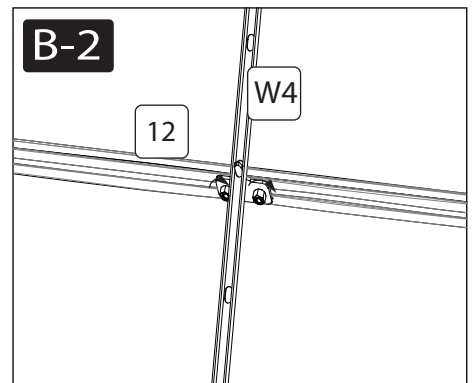
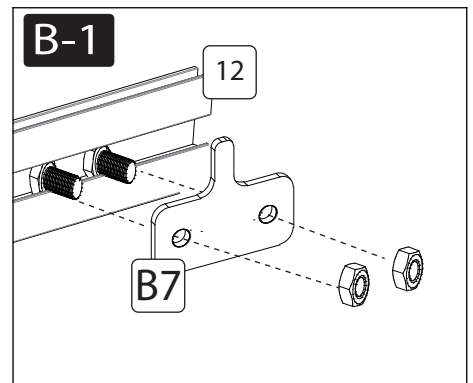

**inside**



Part No.	Part	Qty.
B7		1

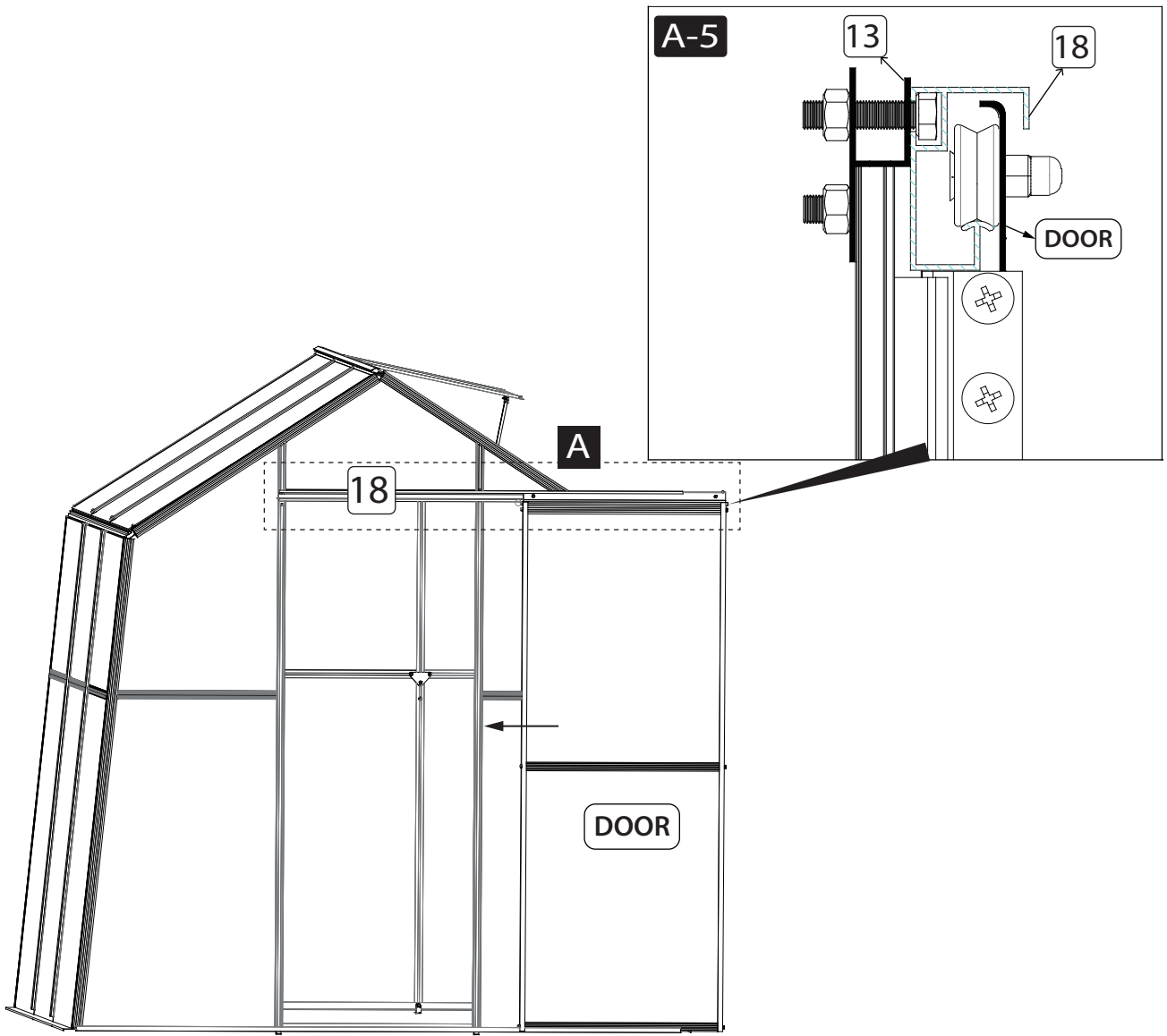

inside

A-1

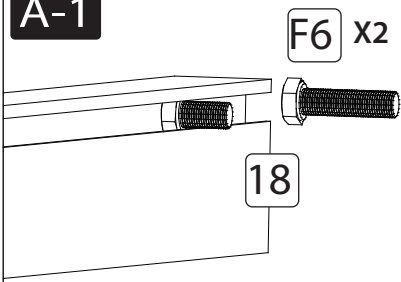

A-2

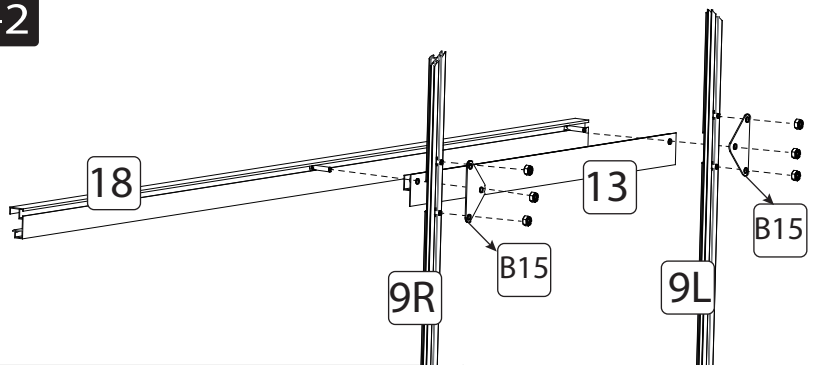

A-2

tighten the nuts on B15 after adjustment of the greenhouse

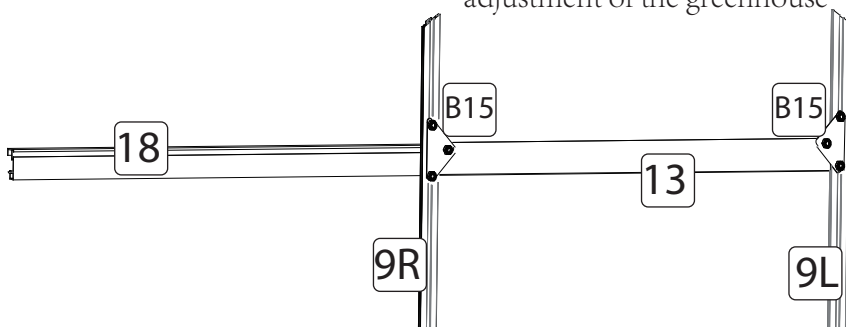

Part No.	Part	Qty.
18		1
13		1
B15		2
F6		2

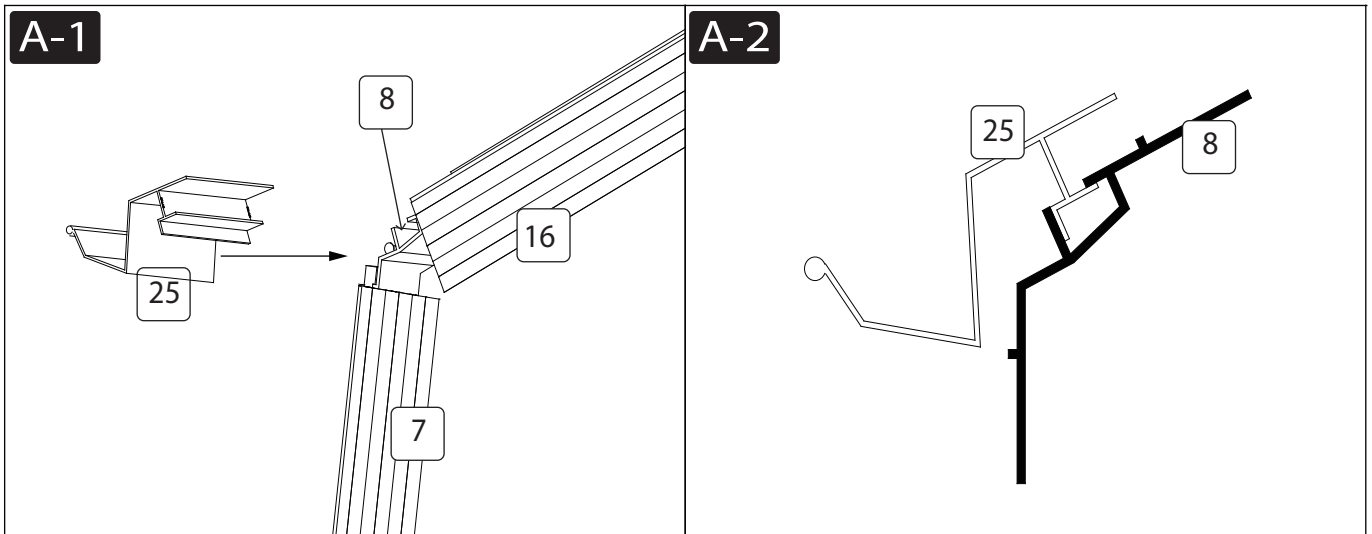
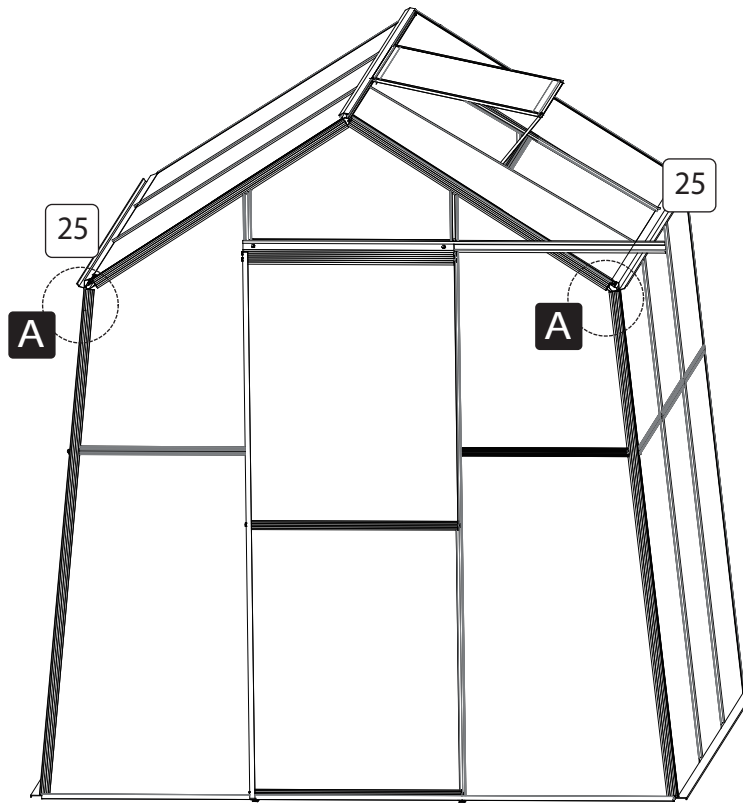

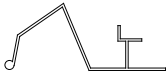
Part No.	Part	Qty.
25		2



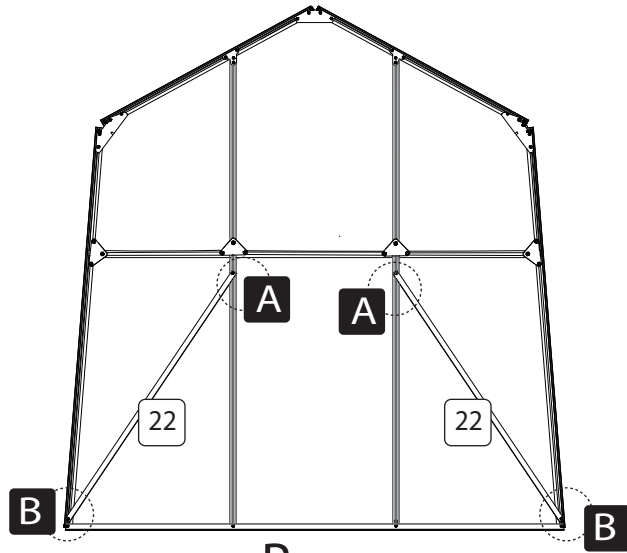

Rear

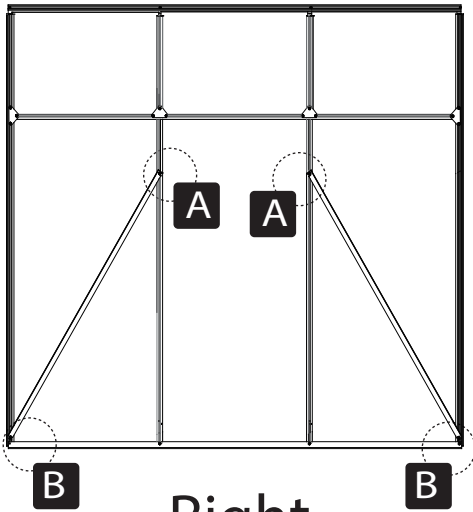

Right

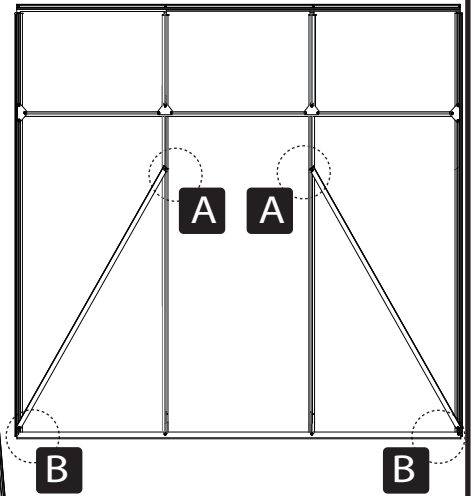

Left

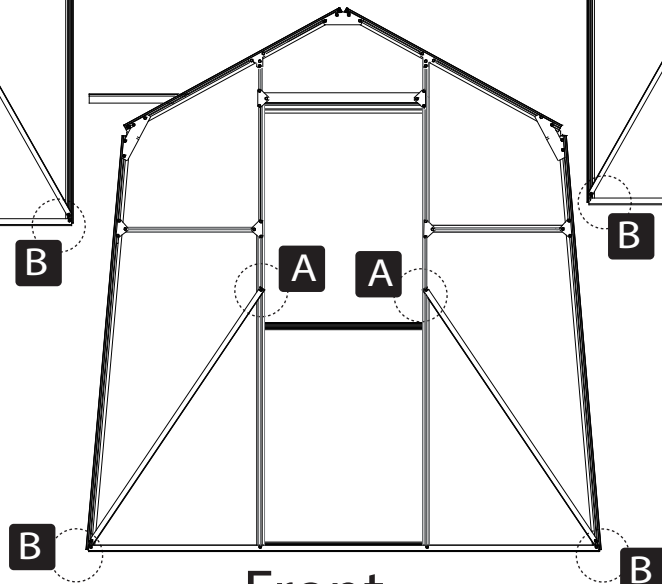

Front

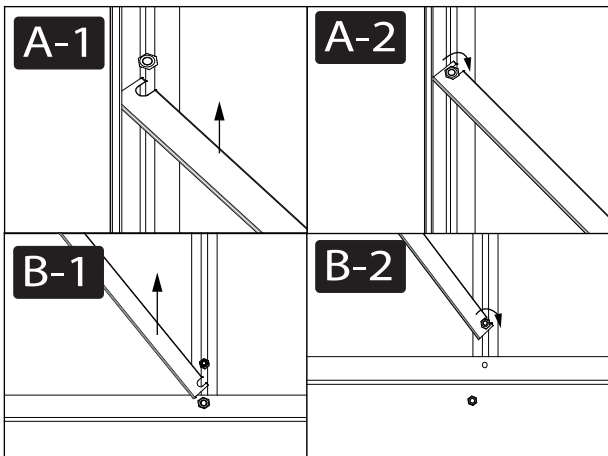

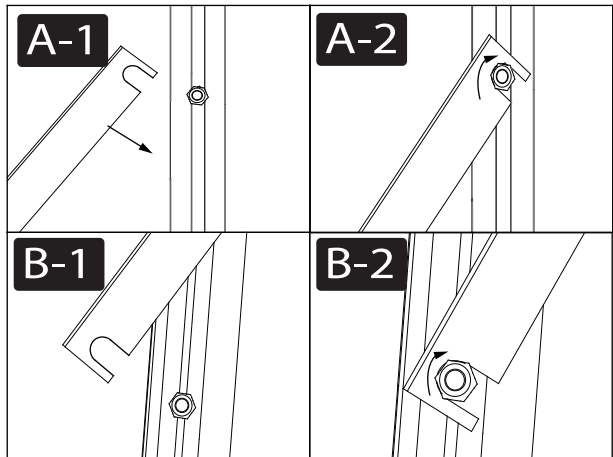

or

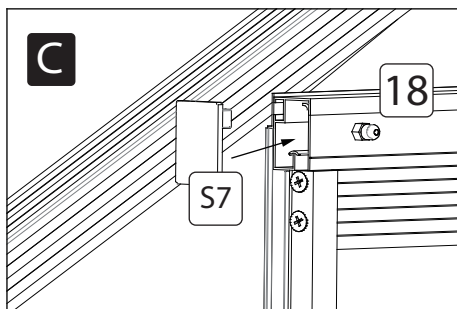
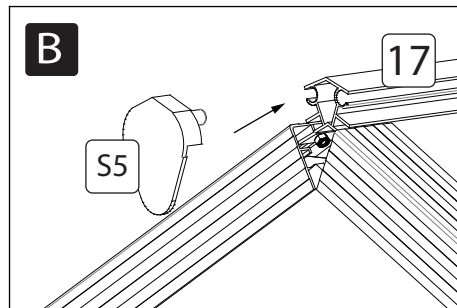
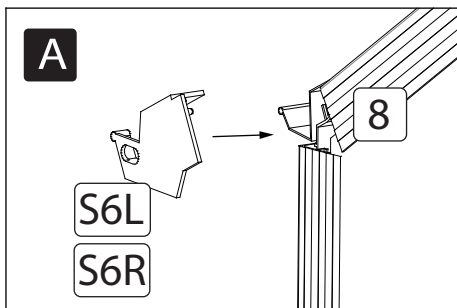
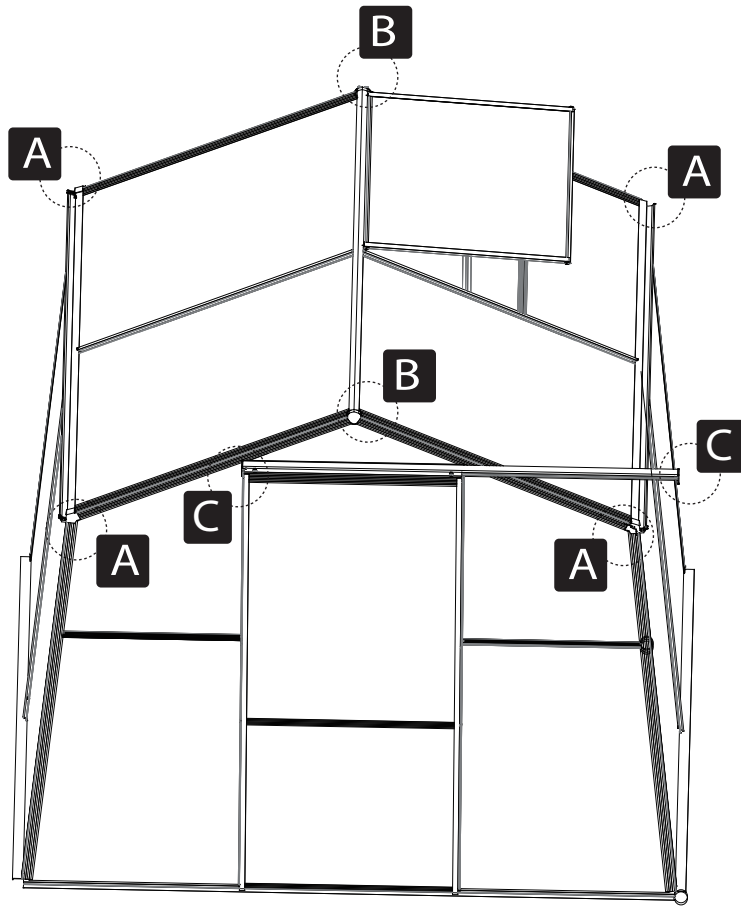

Part No.	Part	Qty.
22		8

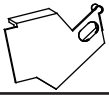

Part No.	Part	Qty.
S6L		2
S6R		2
S5		2
S7		2

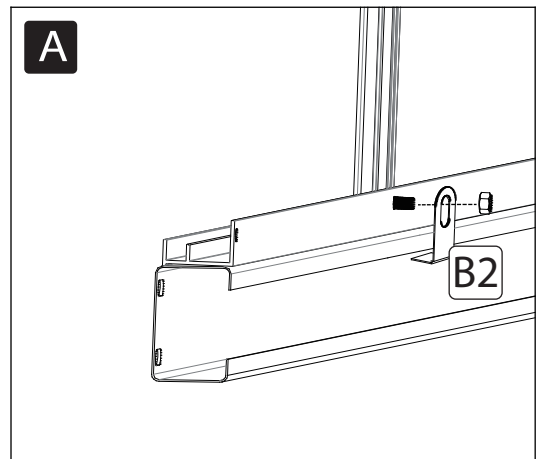
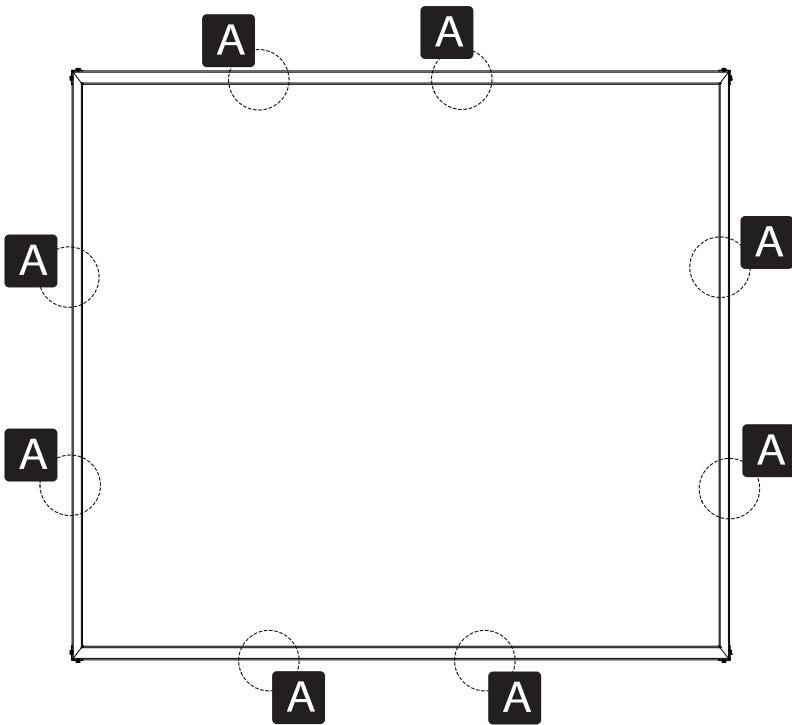
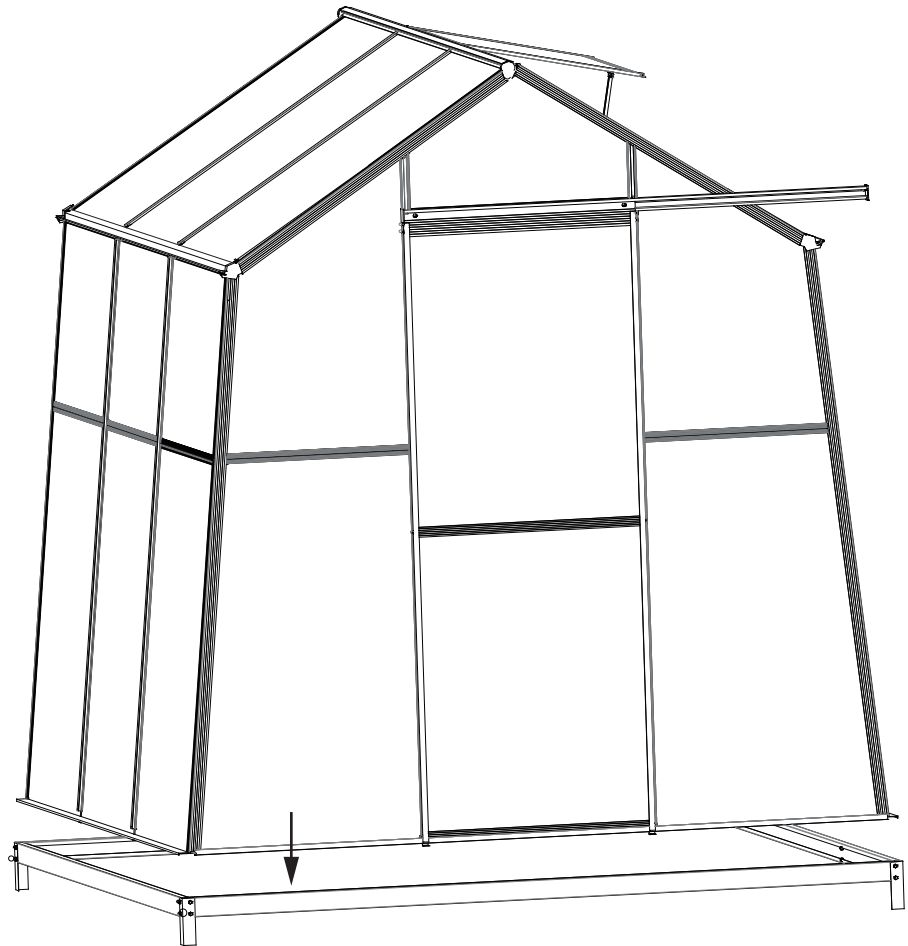

Part No.	Part	Qty.
B2		8

outside

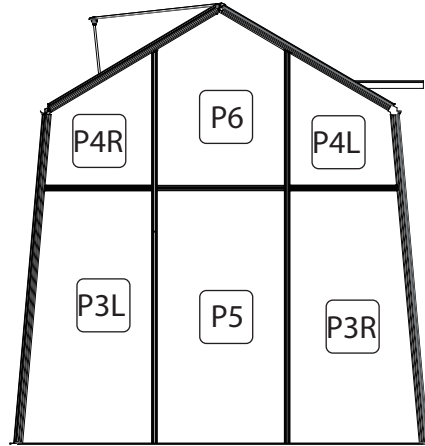

Rear

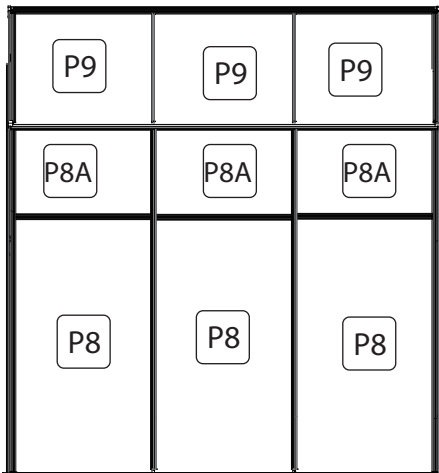

Right

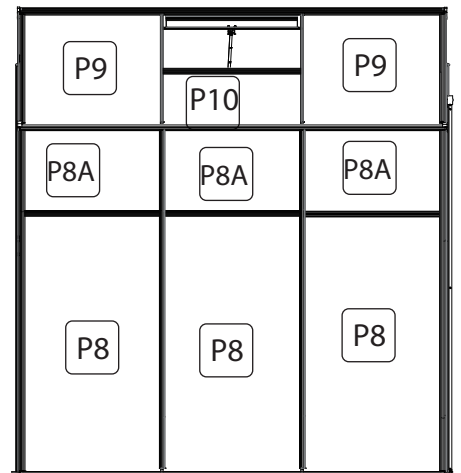

Left

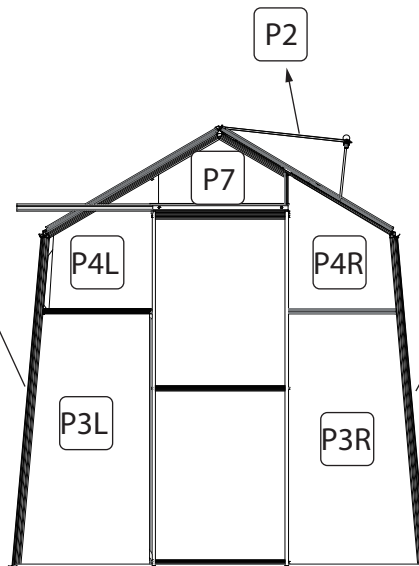

Front

**US**

Imported by Aosom LLC  
27150 SW Kinsman Rd Wilsonville, OR 97070 USA  
MADE IN CHINA

**CA**

Imported by Aosom Canada Inc.  
7270 Woodbine Avenue, Unit 307, Markham, Ontario Canada  
L3R 4B9  
MADE IN CHINA

Importé par Aosom Canada Inc.  
7270 Woodbine Avenue, unité 307, Markham, Ontario Canada  
L3R 4B9  
Fabriqué en Chine

**UK**

IMPORTER ADDRESS:  
MH STAR UK LTD  
Unit 27, Perivale Park,  
Horsenden lane South  
Perivale, UB6 7RH  
MADE IN CHINA

**FR**

ADRESSE D'IMPORTATION:  
MH FRANCE  
2 Rue Maurice Hartmann  
92130 Issy Les Moulineaux  
France  
FABRIQUÉ EN CHINE



Adresses sur [quefairedemesdechets.fr](http://quefairedemesdechets.fr)

**ES**

IMPORTADOR:  
SPANISH AOSOM, S.L.  
C/ROC GROS, Nº15.08550, ELS HOSTALET DE BALENYÀ, SPAIN.  
B66295775  
WWW.AOSOM.ES  
ATENCIONCLIENTE@AOSOM.ES  
TEL: 931294512  
HECHO EN CHINA

**PT**

SPANISH AOSOM, S.L  
C.ROC GROS N.15, 08550. ELS HOSTALET DE BALENYÀ  
TEL: 931294512 (SEG-SEX DAS 7:30H ÀS 16:30H)  
INFO@AOSOM.PT  
WWW.AOSOM.PT

**DE**

ADRESSE DES IMPORTEURS:  
MH Handel GmbH  
Wendenstraße 309  
D-20537 Hamburg  
Germany  
IN CHINA HERGESTELLT

**IT**

IMPORTATO DA:  
AOSOM Italy srl  
Centro Direzionale Milanofiori  
Strada 1 Palazzo F1  
20057 Assago (MI)  
P.I.: 08567220960  
FATTO IN CINA