

Outsunny

IN231000022V01_GL

344-084V00

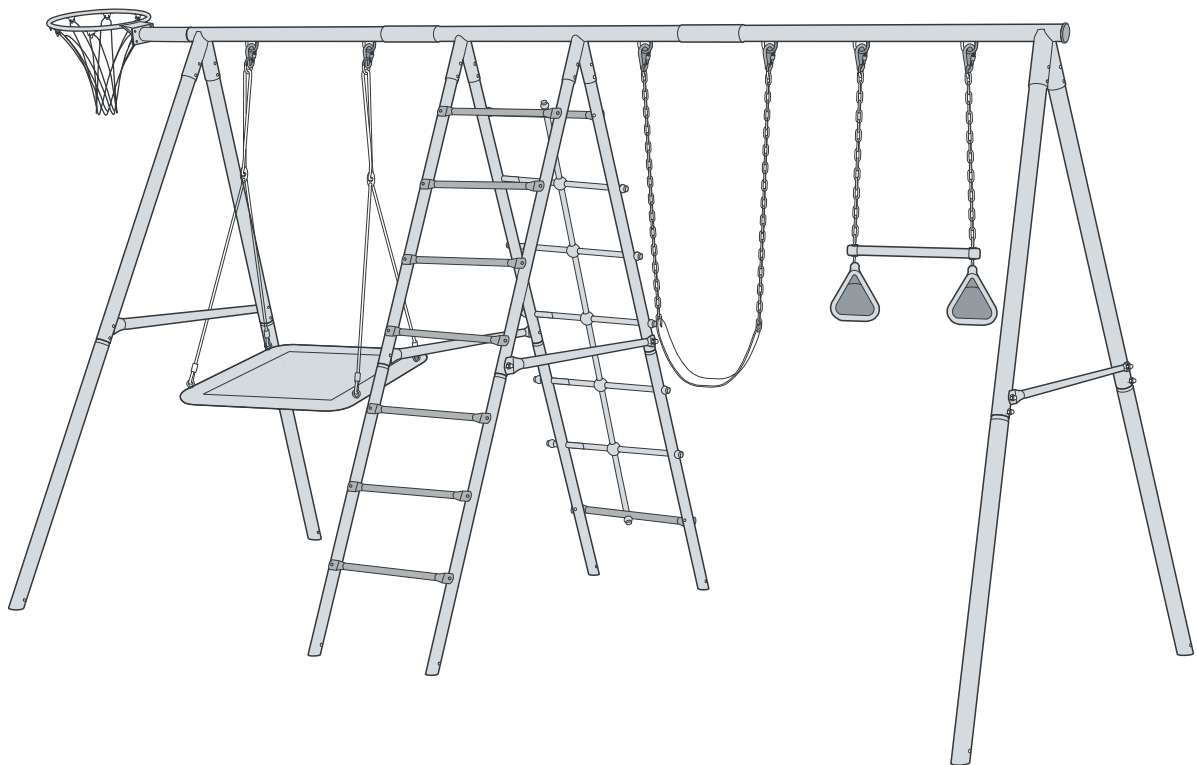

EN: WARNING: Certification Age:3+ years old; Max weight: 40 kg/seat.

DE: WARNUNG: Zertifizierungsalter:3+ Jahre; Max. Gewicht: 40 kg/siège.

FR: ATTENTION: Âge de certification:3+ ans; Poids maximum: 40 kg/Sitz.

ES: ADVERTENCIA: Edad de certificación: 3+ años; Peso máximo: 40 kg/asiento.

PT: AVISO: Idade de certificação: 3+ anos; Peso máximo: 40 kg/assento.

IT: ATTENZIONE: Età di certificazione: 3+ anni; Peso massimo: 40 kg/seduta.

EN_IMPORTANT, RETAIN FOR FUTURE REFERENCE: READ CAREFULLY.

FR_IMPORTANT : A LIRE ATTENTIVEMEN ET A CONSERVER POUR VOUS Y REFERER ULTERIEUREMENT.

ES_IMPORTANTE, LEA Y GUARDE PARA FUTURAS REFERENCIAS.

PT_IMPORTANTE, RETER PARA REFERÊNCIA FUTURA: LEIA ATENTAMENTE.

DE_WICHTIG! SORGFÄLTIG LESEN UND FÜR SPÄTER NACHSCHLAGEN AUFBEWAHREN.

IT_IMPORTANTE! CONSERVARE IL PRESENTE MANUALE PER FUTURO RIFERIMENTO E LEGGERLO ATTENTAMENTE.

EN

WARNING:

1. CHOKING HAZARD—Small parts. Not for children under 3 years.
2. Only allowed for adults to install, keep children away.
3. To be used under the direct supervision of an adult.
4. Check all the parts are well connected before use.
5. Regularly check and maintain the main components (suspenders, fasteners, fixings, etc.), otherwise it may tip over or cause a fall.
6. Installation area should be as wide as possible, flat and avoid dampness.
7. Keep away from fire.
8. Place the activity toy on a level surface at least 2 m from any structure or obstruction such as a fence, garage, house, overhanging branches, laundry lines or electrical wires.
9. Check all nuts and bolts for tightness and tighten when required.
10. Check all coverings for bolts and sharp edges and replace when required.
11. To replace defective parts in accordance with the manufacturer's instructions.

MAINTENANCE

1. Please wipe the surface stains of product with a dry cloth. If necessary, use mild soap or detergent to clean them. After wiping with a soft wet cloth, wipe them with a dry cloth. Do not use a strong acid-alkaline cleaning solution to clean them.
2. If not used for a long time, please put it in a cool and dry place and cover it with clean cloth or blanket.

DE

WARNUNG:

1. ERSTICKUNGSGEFAHR — Kleinteile. Nicht für Kinder unter 3 Jahren geeignet.
2. Nur von Erwachsenen zu installieren, halten Sie Kinder fern.
3. Unter direkter Aufsicht eines Erwachsenen zu verwenden.
4. Prüfen Sie vor dem Gebrauch, ob alle Teile gut miteinander verbunden sind.
5. Prüfen und warten Sie regelmäßig die Hauptbauteile (Aufhängungen, Verschlüsse, Befestigungen usw.), sonst kann es umkippen oder einen Sturz verursachen.
6. Die Aufstellfläche sollte so breit wie möglich sein, flach und trocken.
7. Von Feuer fernhalten.
8. Stellen Sie das Aktivitätsspielzeug auf eine ebene Fläche, die mindestens 2 m von Strukturen oder Hindernissen wie Zäunen, Garagen, Häusern, überhängenden Ästen, Wäscheleinen oder elektrischen Leitungen entfernt ist.
9. Prüfen Sie alle Muttern und Schrauben auf festen Sitz und ziehen Sie sie bei Bedarf nach.
10. Prüfen Sie alle Verkleidungen auf Schrauben und scharfe Kanten und ersetzen Sie sie bei Bedarf.
11. Defekte Teile sind gemäß den Anweisungen des Herstellers zu ersetzen.

WARTUNG

1. Bitte wischen Sie Flecken auf der Oberfläche des Produkts mit einem trockenen Tuch ab. Falls erforderlich, verwenden Sie milde Seife oder Reinigungsmittel, um es zu reinigen. Nach dem Abwischen mit einem weichen, feuchten Tuch, wischen Sie es mit einem trockenen Tuch ab. Verwenden Sie zur Reinigung keine stark säurehaltige oder alkalische Reinigungslösung.
2. Wenn Sie es längere Zeit nicht benutzen, legen Sie es bitte an einen kühlen und trockenen Ort und decken Sie es mit einem sauberen Tuch oder einer Decke ab.

IT

AVVERTIMENTO:

1. **RISCHIO DI SOFFOCAMENTO**— Piccole parti .Non adatte a bambini sotto i 3 anni.
2. È consentita solo l'installazione agli adulti, e tenere lontani i bambini.
3. Da utilizzare sotto la diretta supervisione di un adulto.
4. Controllare che tutte le parti siano ben collegate prima dell'uso.
5. Controllare e mantenere regolarmente i componenti principali (bretelle, elementi di fissaggio, strumenti di fissaggio ecc.), altrimenti potrebbe ribaltarsi o causare una caduta.
6. L'area di installazione deve essere la più ampia possibile, piatta ed evitare l'umidità.
7. Tenere lontano dal fuoco.
8. Posizionare il giocattolo per attività su una superficie piana ad almeno 2 metri da qualsiasi struttura o oggetti di ostruzione come un recinto, un garage, una casa, rami sporgenti, stendibiancheria o cavi elettrici.
9. Controllare che tutti i dadi e bulloni siano serrati e serrarli quando necessario.
10. Controllare tutte le coperture per bulloni e spigoli vivi e sostituirle quando necessario.
11. Sostituire le parti difettose secondo le istruzioni del produttore.

MANUTENZIONE

1. Si prega di pulire le macchie superficiali del prodotto con un panno asciutto. Se necessario, utilizzare sapone neutro o detersivo per pulirli. Dopo aver pulito con un panno morbido inumidito, pulirlo con un panno asciutto. Non utilizzare una forte soluzione detergente acido-alcalina per pulire.
2. Se non viene utilizzato per lungo tempo, conservarlo in un luogo fresco e asciutto e coprirlo con un panno o una coperta puliti.

ES

ADVERTENCIA:

1. **RIESGO DE ASFICIA:** Piezas pequeñas. No es adecuado para los niños menores de 3 años.
2. Solo se permite que los adultos instalen, mantenga a los niños alejados.
3. Para ser utilizado bajo la supervisión directa de un adulto.
4. Verifique que todas las partes estén bien conectadas antes de usar.
5. Revise y mantenga regularmente los componentes principales (tirantes,sujetadores, etc.), de lo contrario podría volcarse o provocar una caída.
6. El área de instalación debe ser lo más amplia posible, plana y evitar la humedad.
7. Mantener alejado del fuego.
8. Coloque el juguete de actividad en una superficie nivelada a una distancia mínima de 2 m de cualquier estructura u obstáculo, como valla, garaje, casa, ramas colgantes, tendederos o cables eléctricos.
9. Compruebe que todas las tuercas y tornillos estén bien apretados y apriételes cuando sea necesario.
10. Compruebe todas las cubiertas para ver si hay pernos sueltos y bordes afilados y sustitúyalos cuando sea necesario.
11. Sustituya las piezas defectuosas de acuerdo con las instrucciones del fabricante.

MANTENIMIENTO

1. Limpie las manchas de la superficie del producto con un paño seco. Si es necesario, use jabón o detergente para limpiarlos. Después de limpiarlos con un paño húmedo suave, límpielos con un paño seco. No utilice una solución de limpieza alcalina-ácida fuerte para limpiarlos.
2. Si no se usa durante mucho tiempo, colóquelo en un lugar fresco y seco y cúbralo con trapo o manta limpia.

PT

ATENÇÃO:

1. PERIGO - Contém peças pequenas. Não para crianças menores de 3 anos.
2. Só é permitida a instalação por adultos, manter as crianças afastadas.
3. Utilizar sob a supervisão direta de um adulto.
4. Verificar se todas as peças estão bem ligadas antes da sua utilização.
5. Verificar e manter regularmente os componentes principais (suportes, fixadores, fixações, etc.), caso contrário pode capotar ou provocar uma queda.
6. A área de instalação deve ser o mais ampla possível, plana e evite colocar em locais húmidos.
7. Manter afastado do fogo.
8. Coloque o brinquedo de atividade em uma superfície plana a pelo menos 2 m de qualquer estrutura ou obstrução, como cerca, garagem, casa, galhos salientes, linhas de lavanderia ou fios elétricos.
9. Verifique o aperto de todas as porcas e parafusos e aperte quando necessário.
10. Verifique todas as coberturas quanto a parafusos e arestas vivas e substitua quando necessário.
11. Substituir peças defeituosas de acordo com as instruções do fabricante.

MANUTENÇÃO

1. Limpar por favor as manchas da superfície com um pano seco. Se necessário, utilizar sabão suave ou detergente para as limpar. Depois de limpar com um pano macio e húmido, limpe-os com um pano seco. Não utilizar uma solução de limpeza ácido-alcalina forte para as limpar.
2. Se não for utilizado durante muito tempo, por favor coloque-o num local fresco e seco e cubra-o com um pano ou cobertor limpo.

FR

AVERTISSEMENT :

1. RISQUE D'ÉTOUFFEMENT— Petites pièces. Déconseillé aux enfants de moins de 3 ans.
2. L'installation n'est autorisée qu'aux adultes, tenez les enfants à l'écart.
3. A utiliser sous la surveillance directe d'un adulte.
4. Vérifiez que toutes les pièces sont bien connectées avant utilisation.
5. Vérifiez et entretenez régulièrement les principaux composants (bretelles, attaches, fixations,), sinon il peut se renverser ou provoquer une chute.
6. La zone d'installation doit être aussi large que possible, plate et éviter l'humidité.
7. Tenez à l'écart de la flamme.
8. Placez le jouet d'activité sur une surface plane à au moins 2 m de toute structure ou obstruction telle qu'une clôture, un garage, une maison, des branches en surplomb, des cordes à linge ou des fils électriques.
9. Vérifiez l'étanchéité de tous les écrous et boulons et serrez-les au besoin.
10. Vérifiez tous les revêtements pour les boulons et les arêtes vives et remplacez-les si nécessaire.
11. Remplacez les pièces défectueuses conformément aux instructions du fabricant.

MAINTENANCE

1. Veuillez essuyer les taches de surface du produit avec un chiffon sec. Si nécessaire, utilisez du savon doux ou du détergent pour le nettoyage. Après l'essuyage avec un chiffon doux et humide, essuyez-les avec un chiffon sec. N'utilisez pas une solution nettoyante fortement acide-alcaline pour le nettoyage.
2. Si vous ne l'utilisez pas pendant une longue période, placez-le dans un endroit frais et sec et couvrez-le d'un tissu ou d'une couverture propre.



Adresses sur quefairedemesdechets.fr

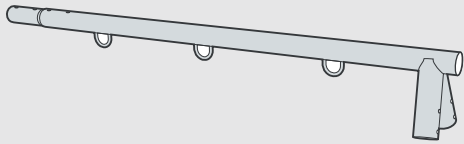

1 X1

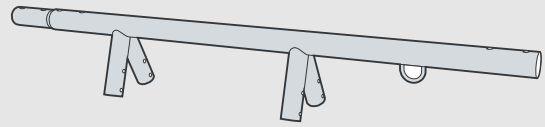

2 X1



3 X1

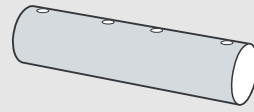

4 X2



5 X1



6 X1



7 X1



8 X4



9 X4



10 X4

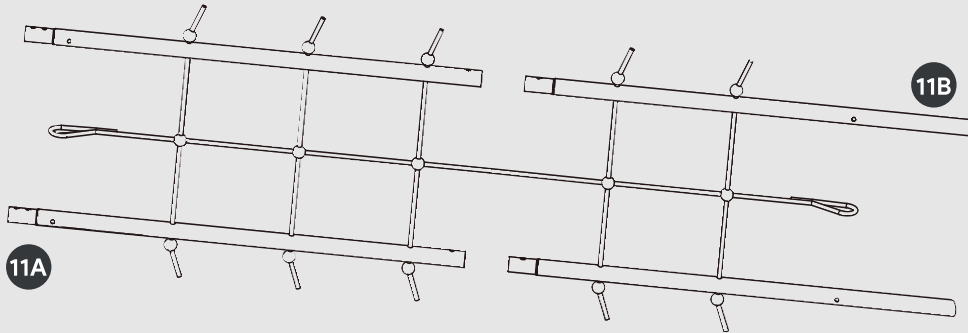

11A

11B

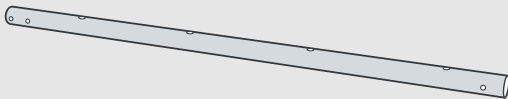

12 X2



13 X2



14 X9

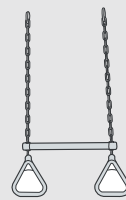

15 X1



16 X1

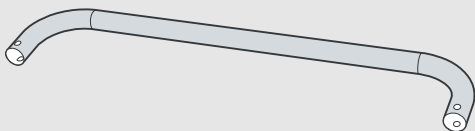

19 X2



17 X2

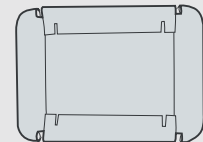

20 X1

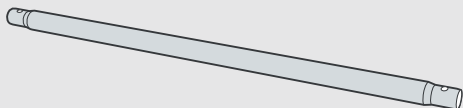

18 X2

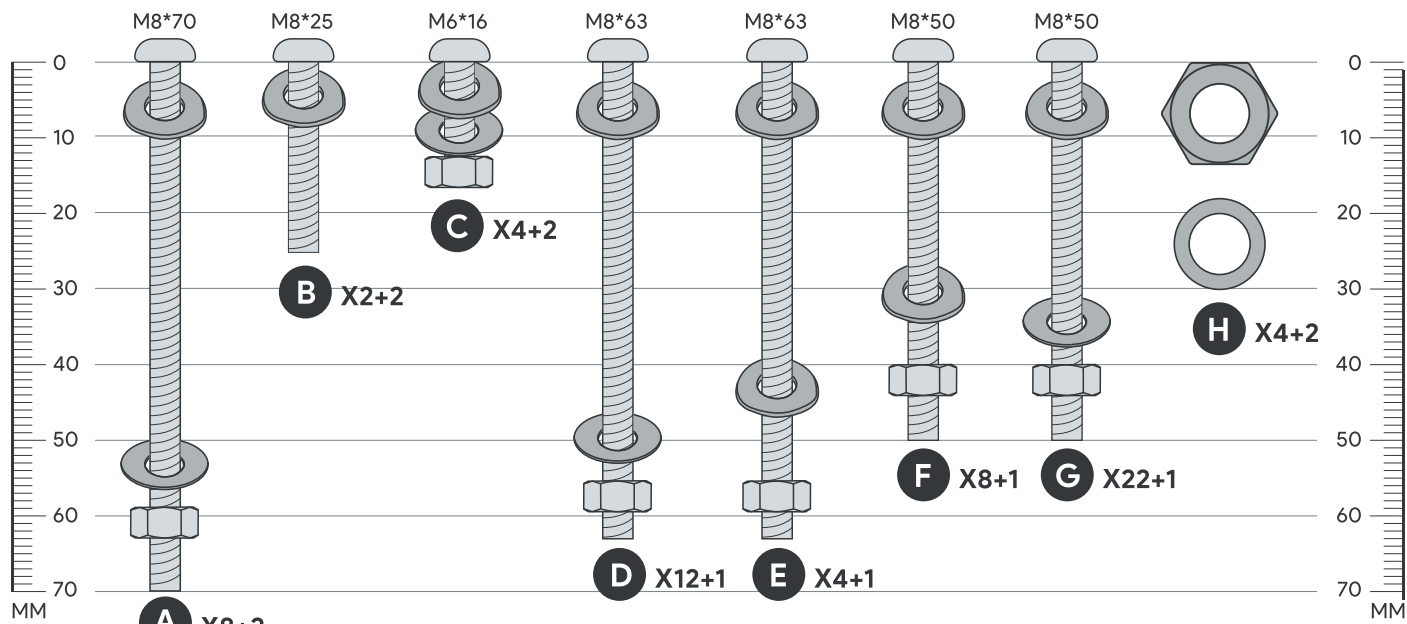

21 X4

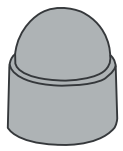

J X54

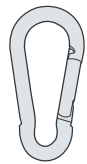

I X6

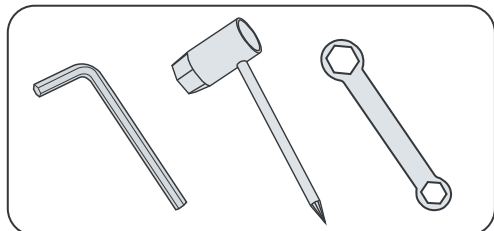

K X1



EN_Do not confuse similar screws. Do not tighten bolts fully until all parts are connected!

FR_Ne pas confondre des vis similaires. Ne serrez pas les boulons à fond tant que toutes les pièces ne sont pas connectées!



ES_No confunda tornillos similares. No apriete los tornillos completamente hasta que todas las partes están conectadas!

PT_Não confundir parafusos semelhantes. Não apertar completamente os parafusos até que todas as peças estejam encaixadas!

DE_Verwechseln Sie ähnliche Schrauben nicht. Ziehen Sie die Schrauben erst fest an, wenn alle Teile verbunden sind!

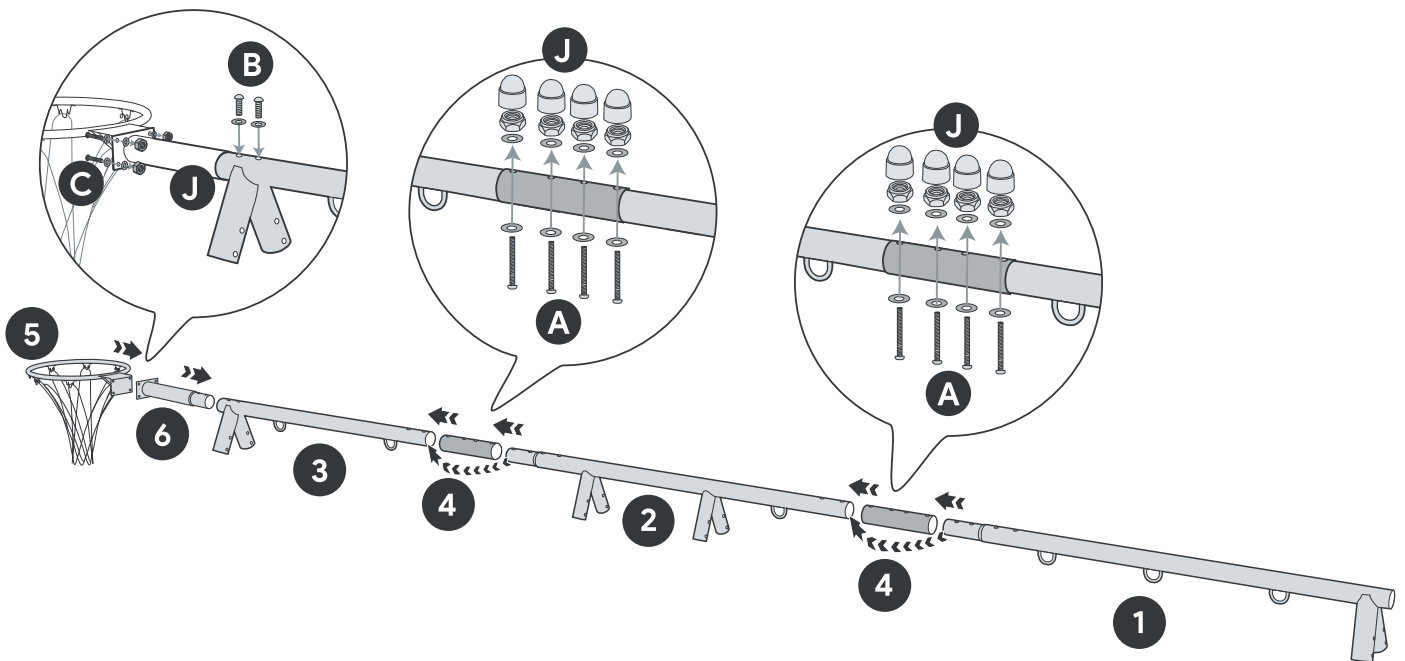
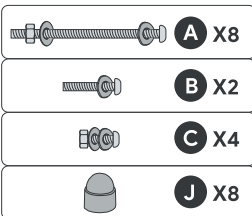
IT_Non confondere le viti simili. Non serrare completamente i bulloni fino a tutte le parti non sono ancora collegate!



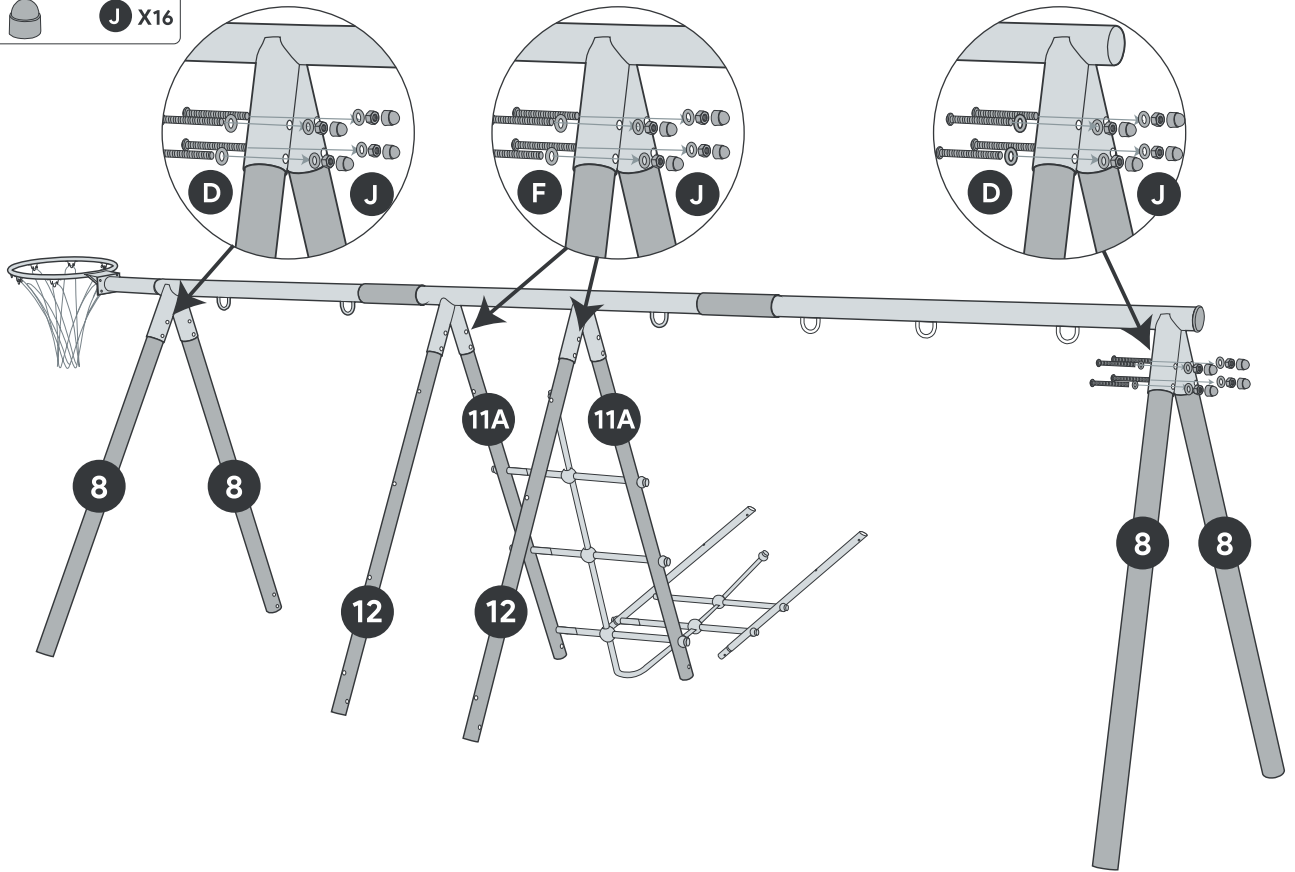

-  **D** X8
-  **F** X8
-  **J** X16

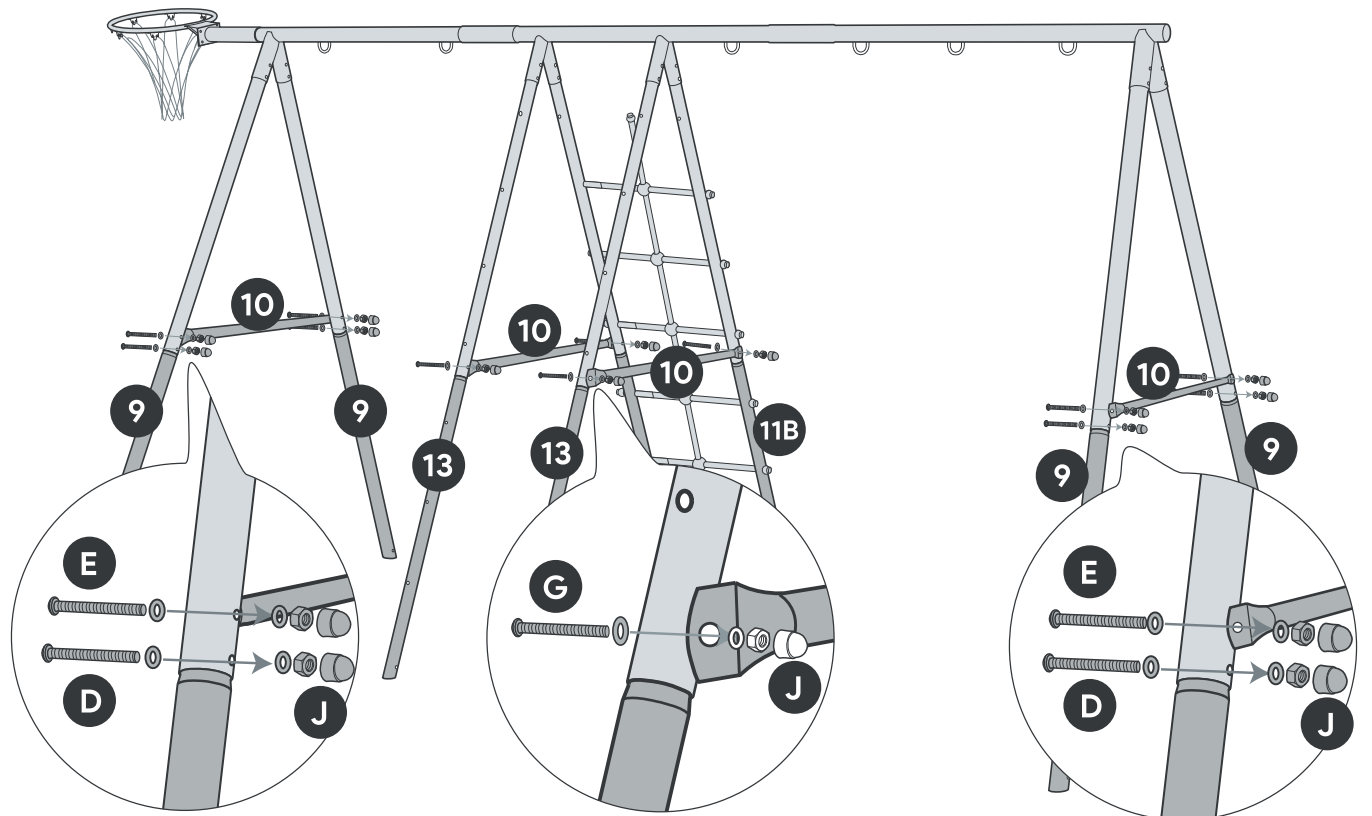

-  **D** X4
-  **G** X4
-  **E** X4
-  **J** X12



-  **G** X18
-  **J** X18

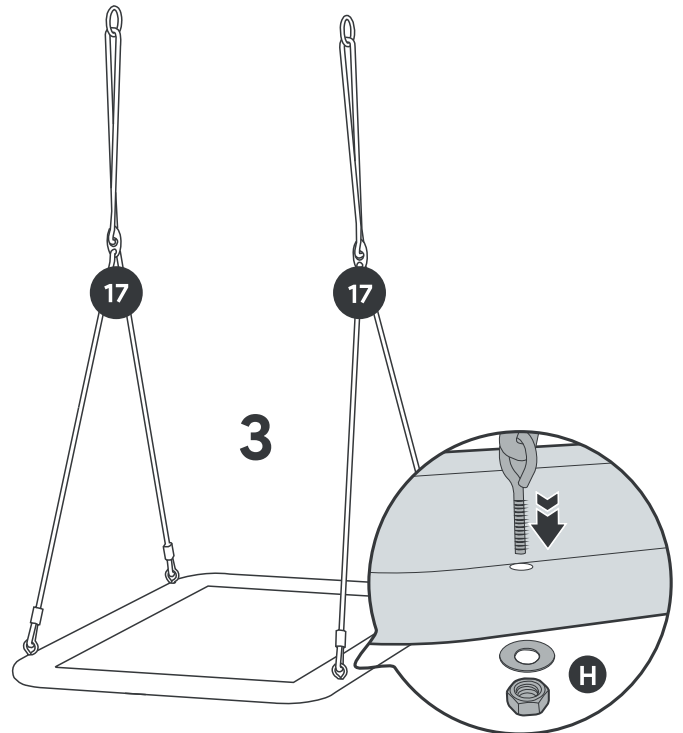
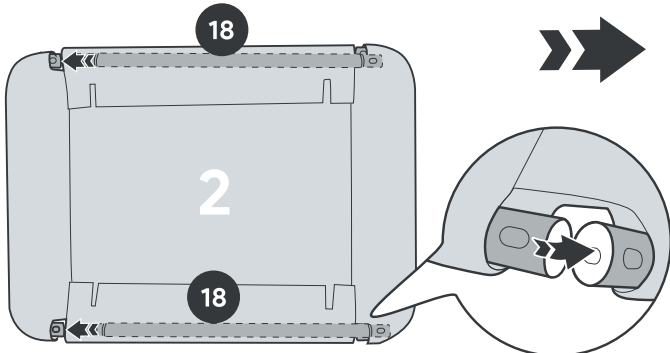
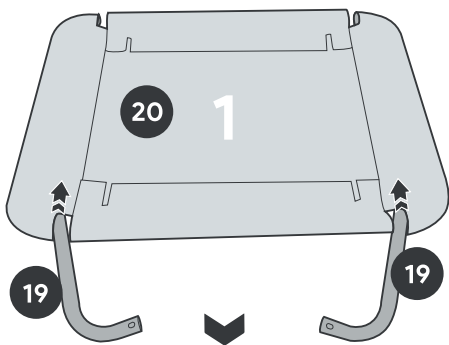
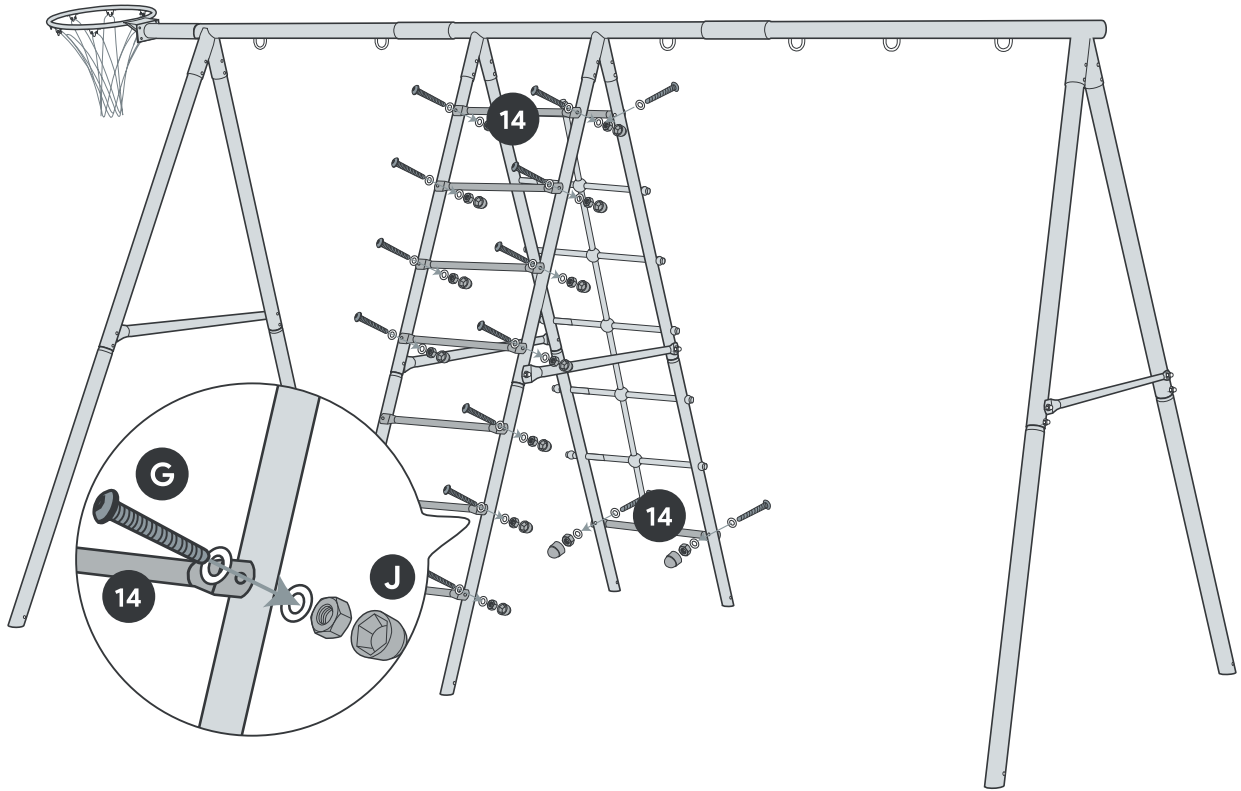

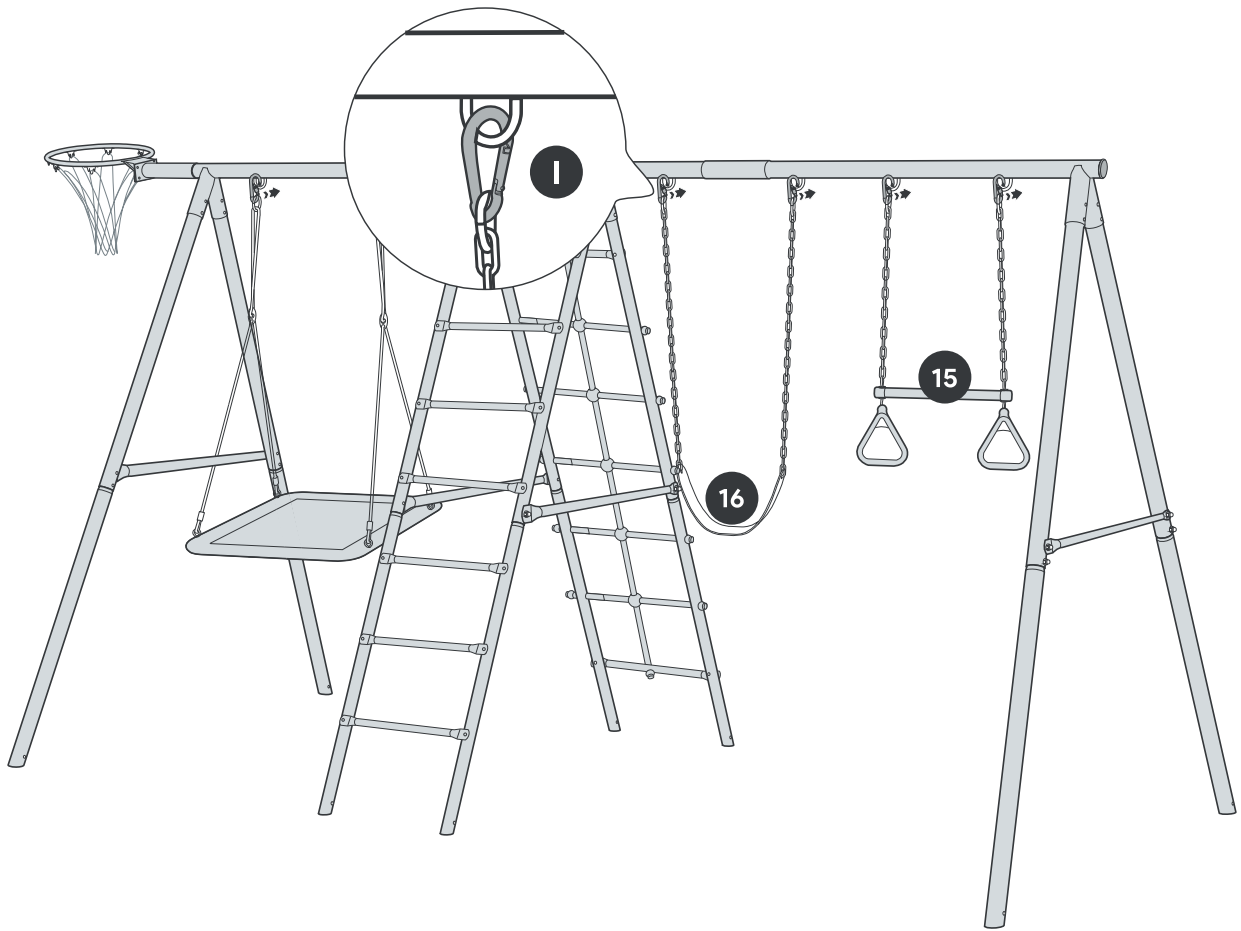
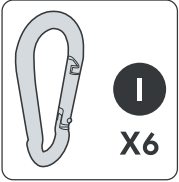

 21 X4

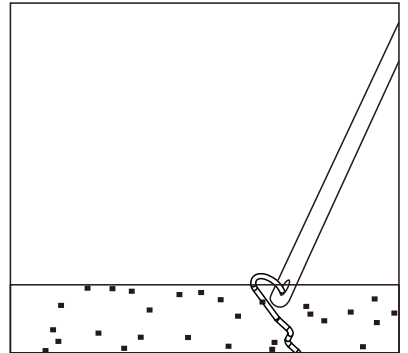
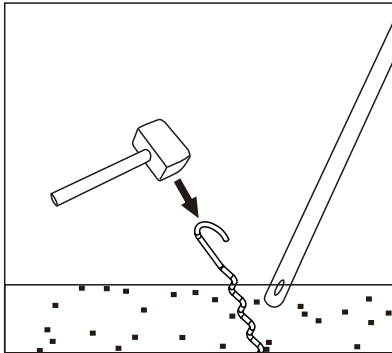
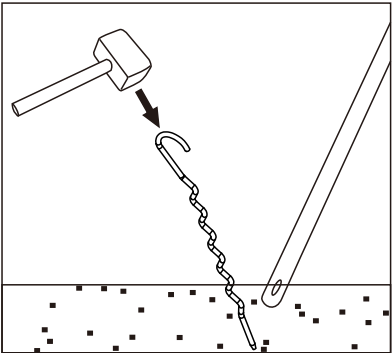
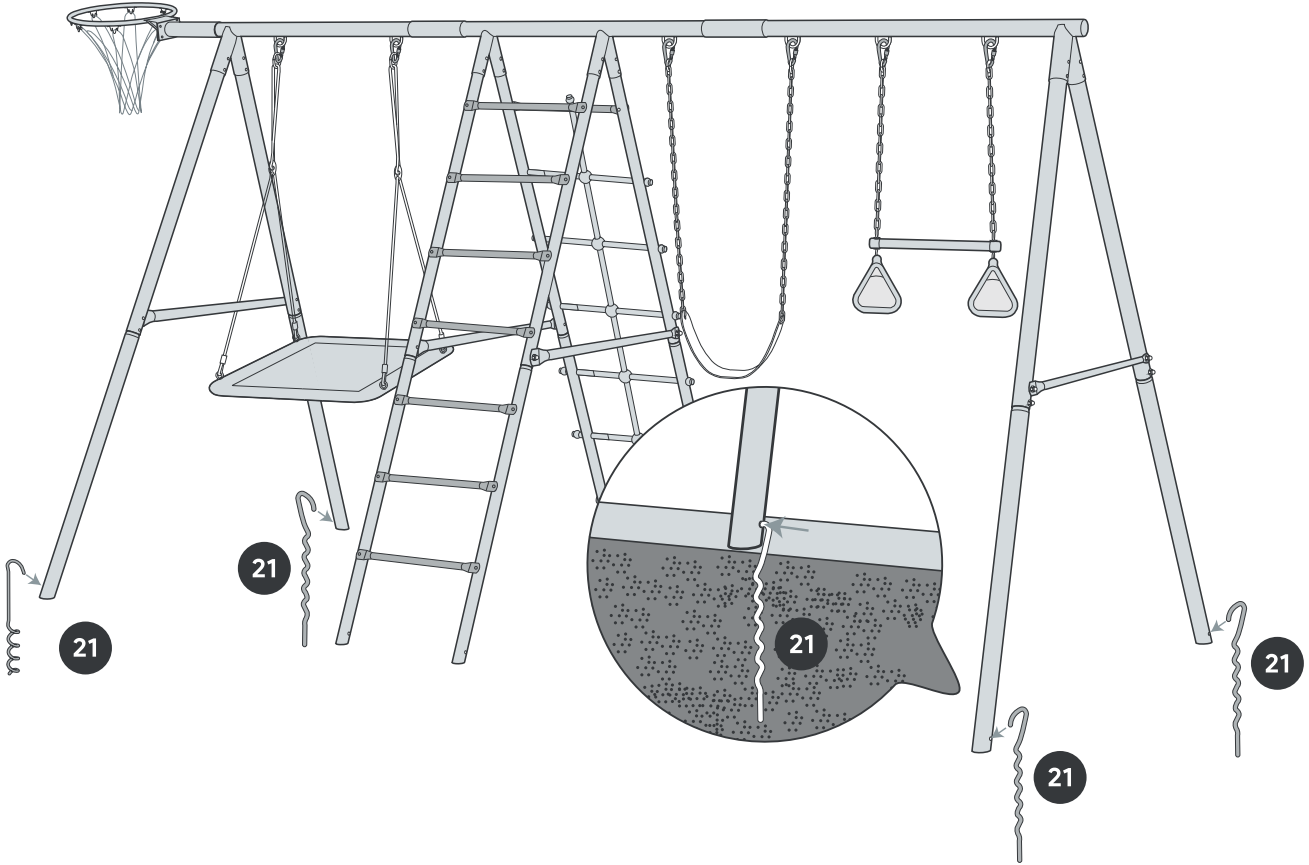

EN**NOTE: ANCHORING**

- If the swing set is set up on grounds with sandy soil condition, it must be anchored with concrete footing(concrete not included).
- Be sure the swing set is located in level ground.
- Dig holes around swing leg tube as shown below in drawing. As you dig down and create a cylindrical hole, you should use shovel to carve out the hole, to create a large diameter hole bottom.
- Place 2 inches brick or gravel bed as shown in drawing below.
- Use about 45lb of concrete per leg.
- Cover concrete with dirt and protective surface material.

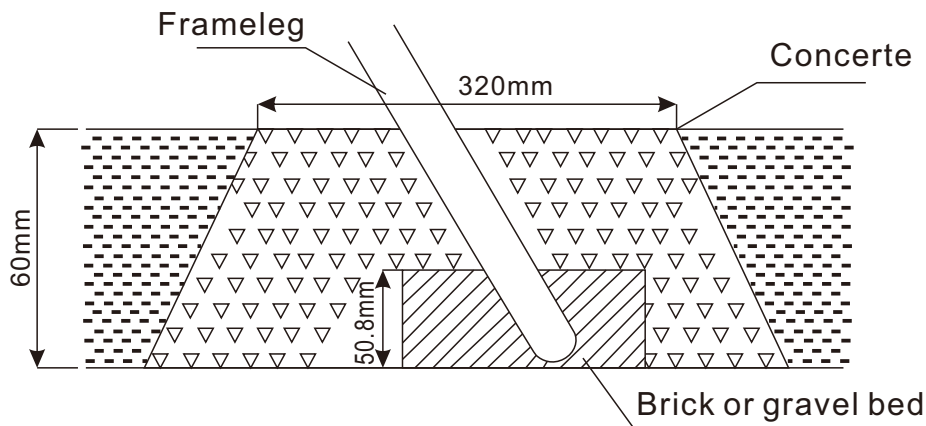
**FR****NOTE: ANCRAGE**

- Si la balançoire est installée sur un terrain sablonneux, elle doit être ancrée avec une semelle en béton (le béton n'est pas inclus) .
- Assurez-vous que la balançoire est installée sur un sol plat.
- Creusez des trous autour du tube des pieds de la balançoire, comme le montre le dessin ci-dessous. En creusant et en créant un trou cylindrique, utilisez une pelle pour évider le trou, afin de créer un fond de trou de grand diamètre.
- Placez une couche de 2 pouces de briques ou de gravier comme indiqué dans le dessin ci-dessous.
- Utilisez environ 45 livres de béton par pied.
- Recouvrez le béton avec de la terre et un matériau de surface protecteur.

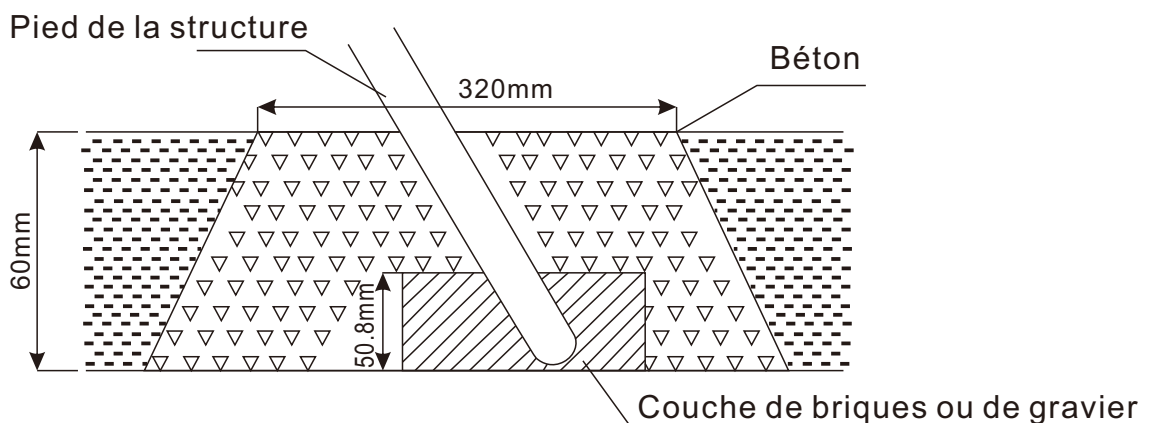

DE

HINWEIS: VERANKERUNG

- Wenn die Schaukel auf einem Gelände mit sandigem Boden aufgestellt wird, muss sie mit einem Betonfundament verankert werden (Beton nicht im Lieferumfang enthalten).
- Vergewissern Sie sich, dass der Aufstellungsort der Schaukel eben ist.
- Graben Sie Löcher um das Rohr der Schaukelbeine herum, wie in der Zeichnung unten gezeigt. Wenn Sie das Loch ausheben und ein zylindrisches Loch erstellen, sollten Sie eine Schaufel verwenden, um das Loch auszugraben und einen großen Durchmesser am Boden zu schaffen.
- Stellen Sie ein 2 Zoll großes Ziegel- oder Kiesbett auf, wie in der Zeichnung unten gezeigt.
- Verwenden Sie etwa 45 lb Beton pro Bein.
- Decken Sie den Beton mit Erde und schützendem Oberflächenmaterial ab.

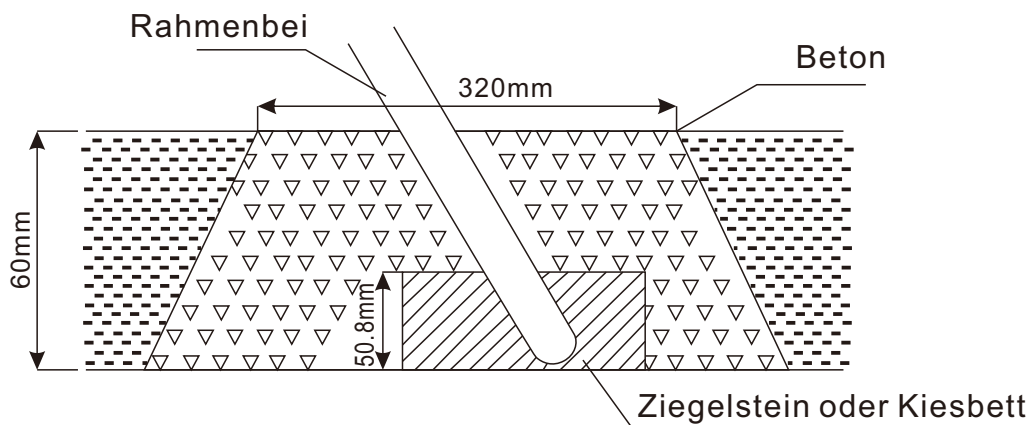
**IT**

NOTA: ANCORAGGIO

- Se l'altalena è stata installata su un terreno sabbioso, deve essere ancorata ad una base in cemento (cemento non in dotazione).
- Assicurarsi che l'altalena sia posizionata su una superficie piana.
- Scavare dei fori attorno al tubo della gamba dell'altalena come mostrato di seguito in figura. Assicurarsi di utilizzare una pala per scavare il foro, per creare un foro cilindrico di grande diametro.
- Posizionare un letto di mattoni o ghiaia con uno spessore di 2 pollici come mostrato in figura sottostante.
- Utilizzare circa 45 libbre di cemento per gamba.
- Coprire il calcestruzzo con terriccio e uno strato protettivo in superficie.

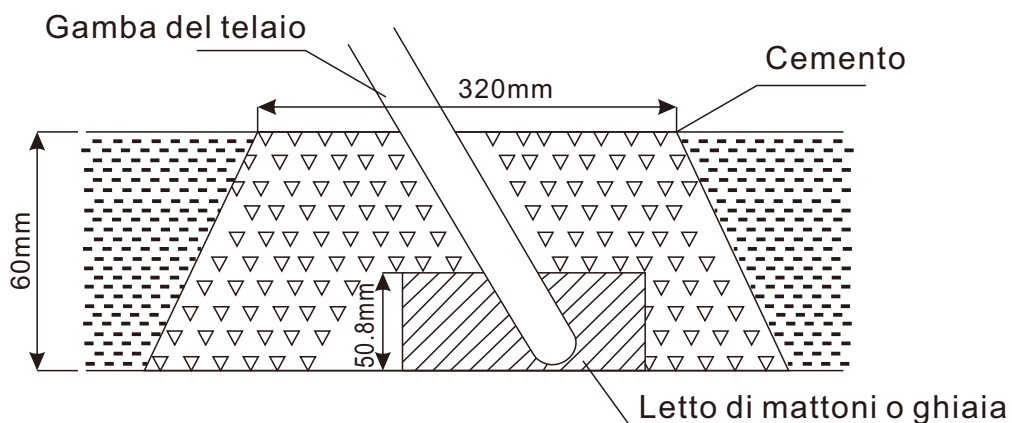

ES**NOTA: ANCLAJE**

- Si el columpio se monta en un terreno arenoso, deberá anclarse con una base de hormigón (hormigón no incluido).
- Asegúrese de que el columpio esté instalado en un terreno nivelado.
- Excave agujeros alrededor del tubo de la pata del columpio como lo que se muestra en la siguiente imagen. Cuando usted excava y crea un agujero cilíndrico, debe utilizar una pala para excavar el agujero, y crear un fondo de agujero de gran diámetro.
- Coloque un lecho de ladrillos o grava de 2 pulgadas de espesor como lo que se muestra en la siguiente imagen.
- Utilice aproximadamente 45 libras de hormigón para anclar cada pata.
- Cubra el hormigón con tierra y materiales protectores para la superficie.

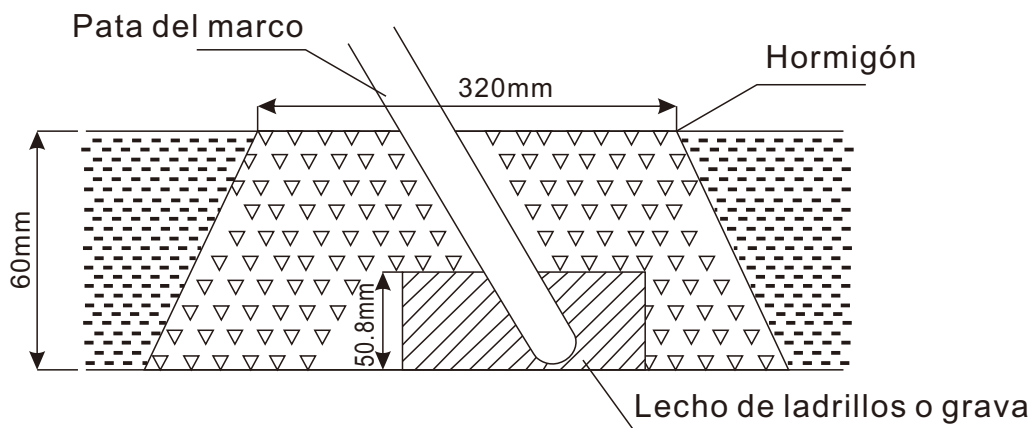
**PT****NOTA: ANCORAGEM**

- Se o conjunto de balanço for montado em terrenos com solo arenoso, ele deverá ser ancorado com base de concreto (concreto não incluído).
- Certifique-se de que o conjunto de balanço esteja localizado em um terreno nivelado.
- Faça buracos ao redor do tubo da perna do balanço, conforme mostrado no desenho abaixo. Ao cavar para baixo e criar um buraco cilíndrico, você deve usar uma pá para abrir o buraco e criar um fundo com diâmetro relativamente grande.
- Coloque uma camada de 2 polegadas de tijolos ou cascalho, conforme mostrado no desenho abaixo.
- Use cerca de 45 lb de concreto por perna.
- Cubra o concreto com solo e material protetor de superfície.

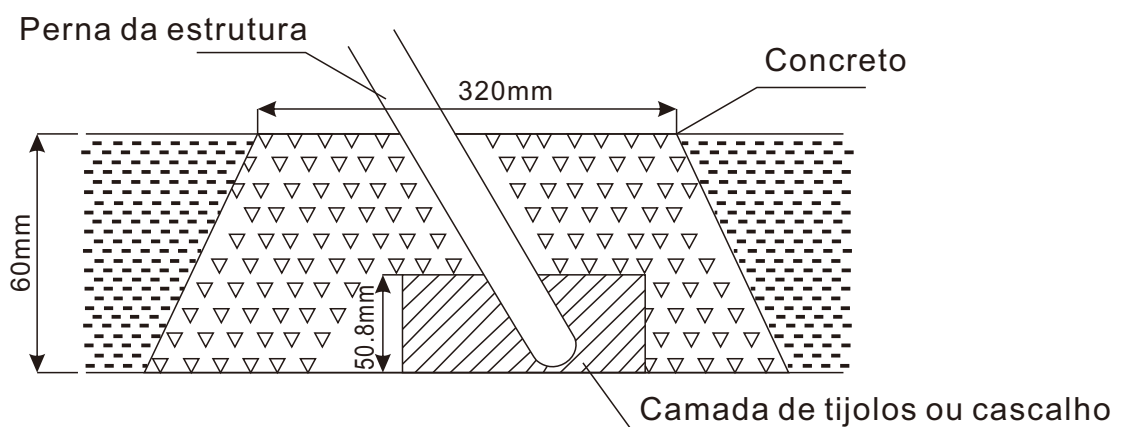

UK

If you have any questions, please contact our customer care centre.

Our contact details are below:



0044-800-240-4004



enquiries@mhstar.co.uk

IMPORTER ADDRESS:

MH STAR UK LTD

Unit 27, Perivale Park,

Horsenden lane South

Perivale, UB6 7RH

MADE IN CHINA

ES

Si tiene alguna pregunta, comuníquese con nuestro Centro de Atención al Cliente. Nuestros datos de contacto son los siguientes:



0034-931294512



atencioncliente@aosom.es

IMPORTADOR:

SPANISH AOSOM, S.L.

C/ ROC GROS, N° 15. 08550, ELS HOSTALETS DE

BALENYÀ, SPAIN.

B66295775

WWW.AOSOM.ES

ATENCIONCLIENTE@AOSOM.ES

TEL: 931294512

HECHO EN CHINA

FR

Si vous avez la moindre question, veuillez contacter notre centre d'assistance à la clientèle.

Nos coordonnées sont les suivantes:



0033-1-84166106



aosom@mhfrance.fr

Importé par:

MH France

2, rue Maurice Hartmann

92130 Issy-les-Moulineaux

France

Fabriqué en Chine

PT

Se tiver alguma dúvida, por favor contacte o nosso Centro de Atendimento ao Cliente. Os nossos dados de contacto são os seguintes:



0034-931294512



info@aosom.pt.

IMPORTADOR:

SPANISH AOSOM, S.L

C.ROC GROS N.15, 08550. ELS HOSTALETS DE BALENYÀ

TEL: 931294512 (SEG-SEX DAS 7:30H ÀS 16:30H)

INFO@AOSOM.PT

WWW.AOSOM.PT

DE

Wenn Sie Fragen haben, wenden Sie sich bitte an unser Kundendienstzentrum.

Unsere Kontaktdaten stehen unten:



0049-0(40)-88307530



service@aosom.de

ADRESSE DES IMPORTEUR:

MH Handel GmbH

Wendenstraße 309

D-20537 Hamburg

Germany

IN CHINA HERGESTELLT

IT

In caso di dubbio, si prega di contattare il nostro centro assistenza clienti. I nostri dettagli di contatto sono di seguito:



0039-0249471447



clienti@aosom.it

IMPORTATO DA:

AOSOM Italy srl

Centro Direzionale Milanofiori

Strada 1 Palazzo F1

20057 Assago (MI)

P.I.: 08567220960

FATTO IN CINA

US

If you have any questions, please contact our customer care center.
Our contact details are below:



001-877-644-9366



customerservice@aosom.com

Imported by Aosom LLC
27150 SW Kinsman Rd Wilsonville, OR 97070 USA
MADE IN CHINA

CA

If you have any questions, please contact our customer care center.
Our contact details are below:

Si vous avez la moindre question, veuillez contacter notre centre d'assistance à la clientèle.
Nos coordonnées sont les suivantes:



416-792-6088



customerservice@aosom.ca

Imported by Aosom Canada Inc.
7270 Woodbine Avenue, Unit 307, Markham, Ontario Canada
L3R 4B9
MADE IN CHINA

Importé par Aosom Canada Inc.
7270 Woodbine Avenue, unité 307, Markham, Ontario Canada
L3R 4B9
FABRIQUÉ EN CHINE

