

PawHut

IN231000327V01_US_UK_IT

D06-094V03_D06-094V07

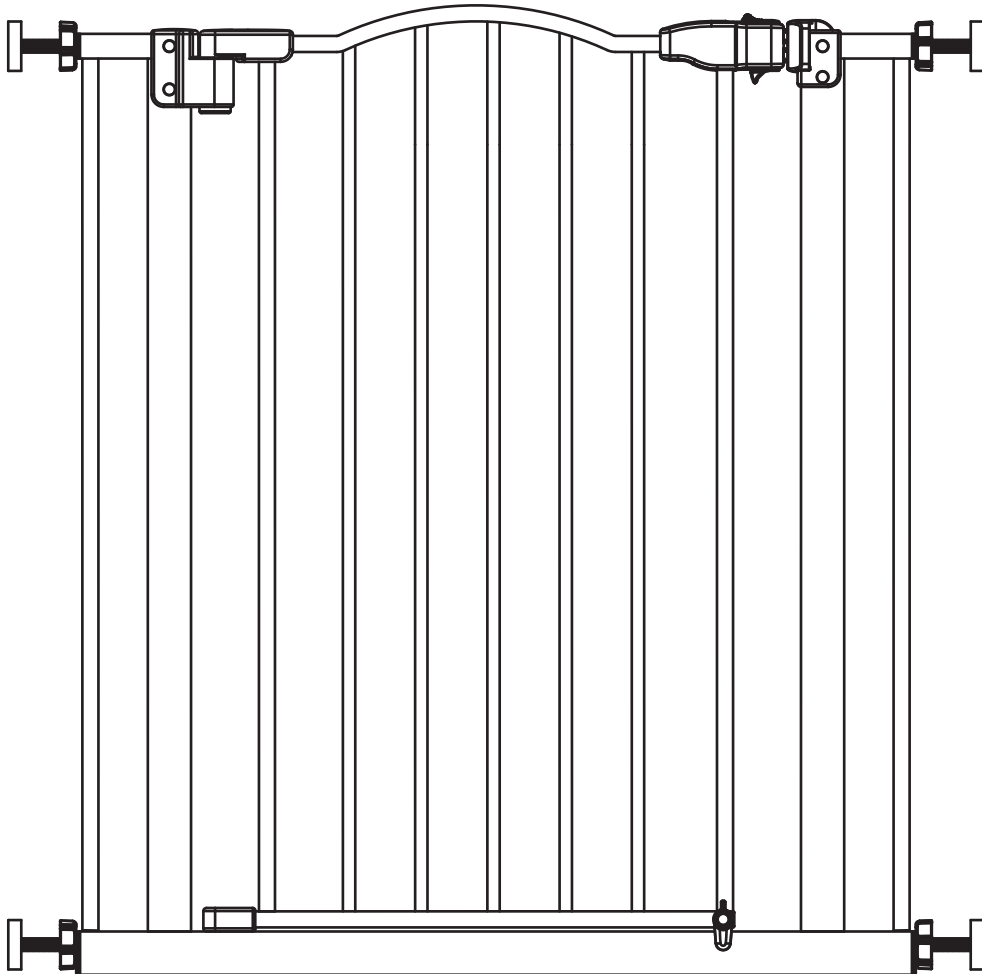

EN_IMPORTANT, RETAIN FOR FUTURE REFERENCE: READ CAREFULLY.

FR_IMPORTANT: A LIRE ATTENTIVEMENT ET À CONSERVER POUR CONSULTATION ULTÉRIEURE.

ES_IMPORTANTE, LEA Y GUARDE PARA FUTURAS REFERENCIAS.

PT_IMPORTANTE, RETER PARA REFERÊNCIA FUTURA: LEIA ATENTAMENTE.

DE_WICHTIG! SORGFÄLTIG LESEN UND FÜR SPÄTER NACHSCHLAGEN AUFBEWAHREN.

IT_IMPORTANTE! CONSERVARE IL PRESENTE MANUALE PER FUTURO RIFERIMENTO E LEGGERLO ATTENTAMENTE.

BEFORE USING PRODUCT

IMPORTANT

- Improper installation could result in the gate becoming unstable or dislodged from the doorway.
- Base locks are to be used at all times, on both sides of the gate.
- This product will not necessarily prevent all accidents.
- **Check the gate regularly to see if all the hardware and mountings are tightened.**
- Do not use if any components are missing or damaged.
- STOP using when a pet can climb over or dislodge the gate.
- Additional or replacement parts should only be obtained from the manufacturer or distributor.

WARNING

Children have died or been seriously injured when gates are not securely installed.

- ALWAYS install and use gates as directed using all required parts.
- YOU must install wall cups to keep gate in place. Without wall cups, child can push out and escape.
- STOP using when a child can climb over or dislodge the gate.
- USE only with the locking mechanism securely engaged.
- NEVER use to keep child away from pool.

- NEVER leave child unattended.
- Intended for use with children between 6 and 24 months.
- Install according to manufacturer' s instructions.

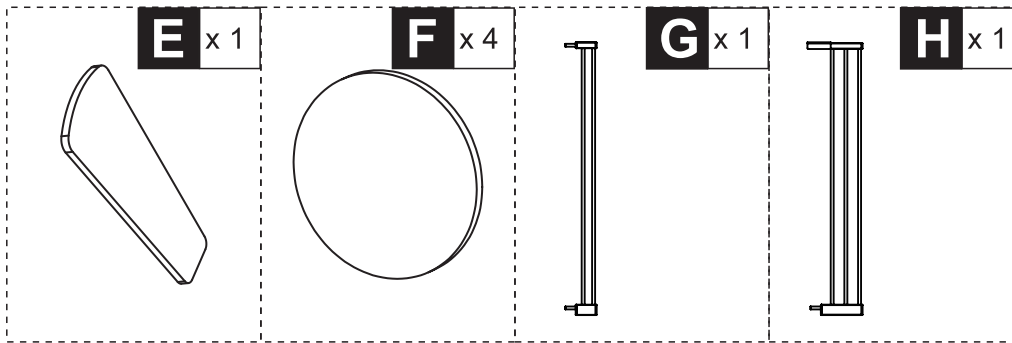
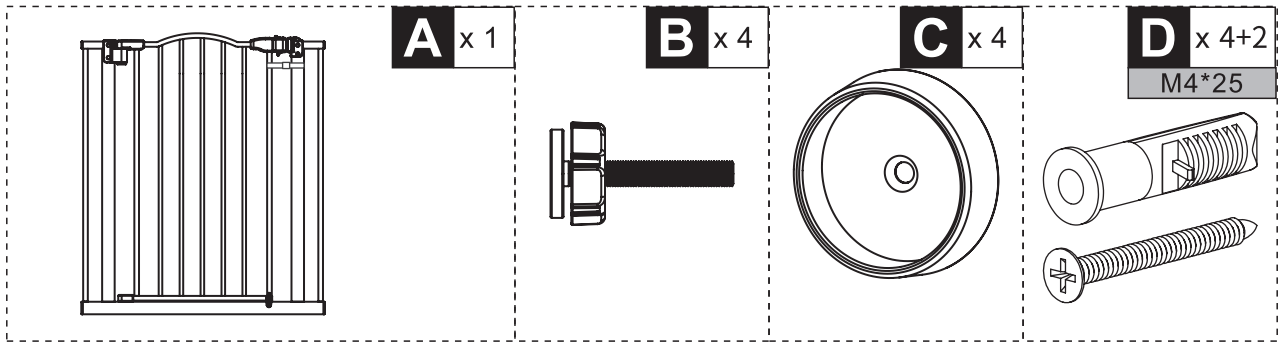

EXTENSIONS AND MAX SIZE

MODEL NO.	No Extension	7cm(2.75in) Extension	14cm(5.51in) Extension	MAX SIZE
D06-094V03	✓	✓	✓	29 - 39inch
D06-094V07	✓	✓	✓	29 - 39inch

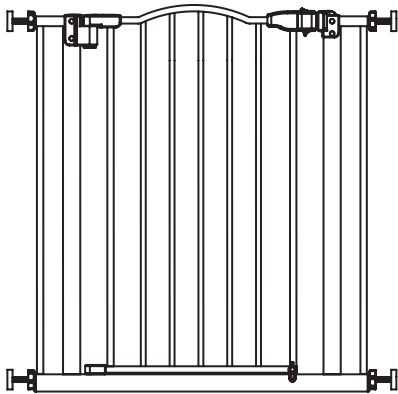

No Extension
74 - 79cm
29 - 31 inch



With 7cm(2.75in)
81 - 86cm
31.5 - 33.5 inch

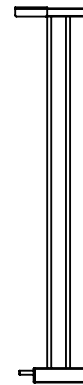

With 14cm(5.51in)
88 - 93cm
34.5 - 36.5 inch

INSTALLING YOUR GATE

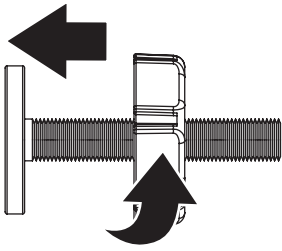
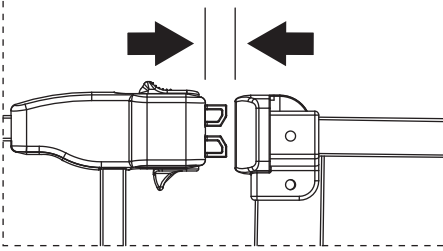

Figure 1-1

Locate the (4) threaded spindle rods (B). Rotate the adjustment wheels along the threading, eliminating the gap between the adjustment wheel and the rubber foot (Figure 1-1).

Figure 1-2



NOTE You may notice a slight gap between the gate door latch and the frame (Figure 1-2).

THIS IS NOT A DEFECT this gate is a pressure mounted gate and this gap will disappear once you tighten the gate in its opening.

Figure 1-3

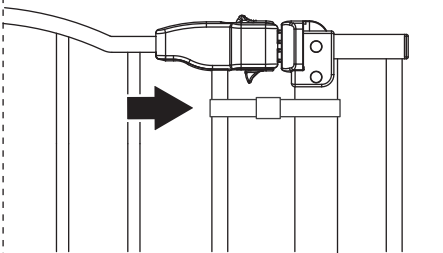

DO NOT REMOVE THE ZIP TIE UNTIL INSTALLATION IS COMPLETE.

(Figure 1-3)

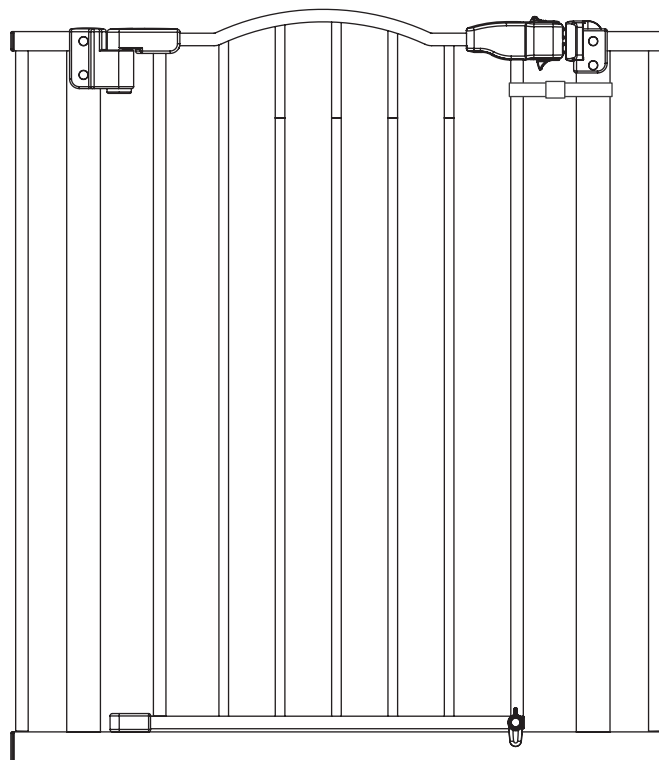
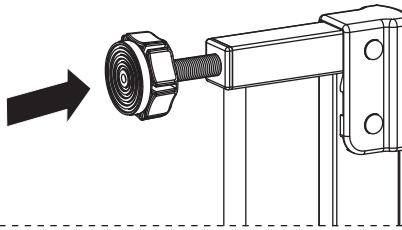
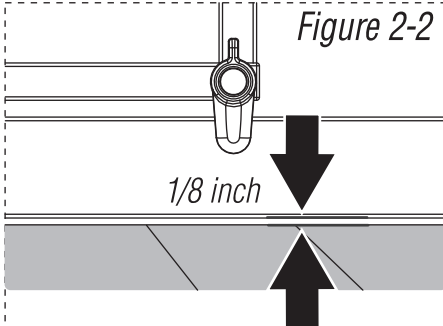

Figure 2-1



Insert the threaded spindle rods with adjustment wheels into the hole on all four corners of the sides of the gate. (Figure 2-1)

Figure 2-2



Place the gate in desired opening with the bottom close to the floor. The distance between the bottom of the gate and the floor should be less than 1/8 inch (Figure 2-2).

Figure 2-3

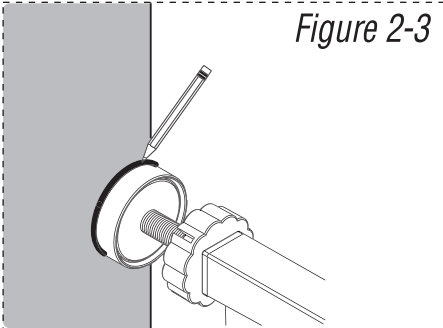

Once you are satisfied with the placement of your gate trace the spindle rods rubber feet onto the surface of your opening making sure these are level (Figure 2-3). Then remove the gate from the opening. Then screw the 4 wall cups to the wall using the screws (Figure 2-4), or paste the 4 wall cups using the stickers provided (Figure 2-5).

Figure 2-4

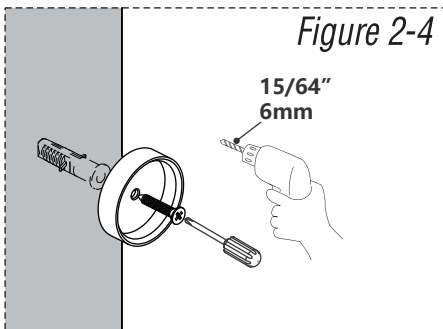

Figure 2-5

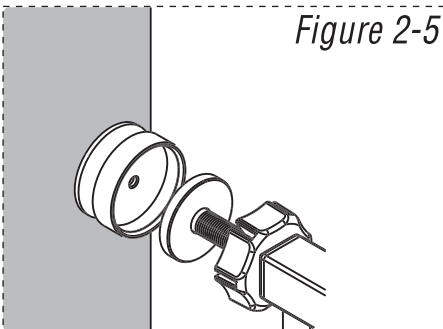

Figure 3-1

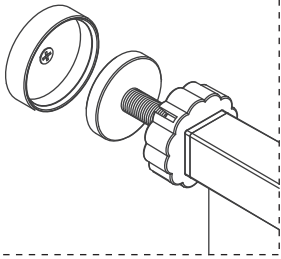

Figure 3-2

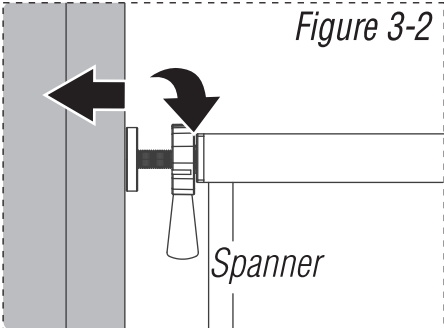

Figure 3-3

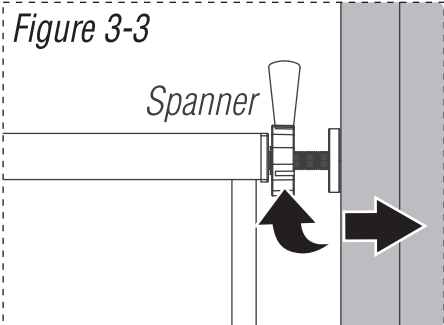

Figure 3-4

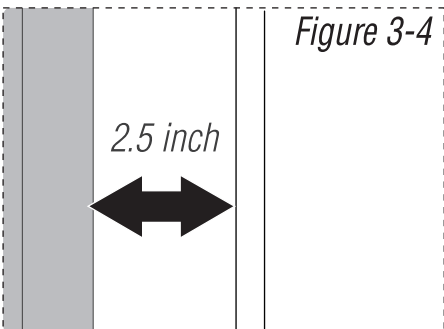

Figure 3-5

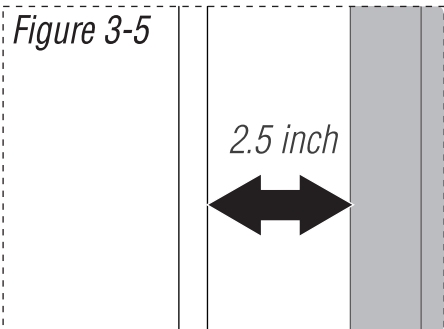
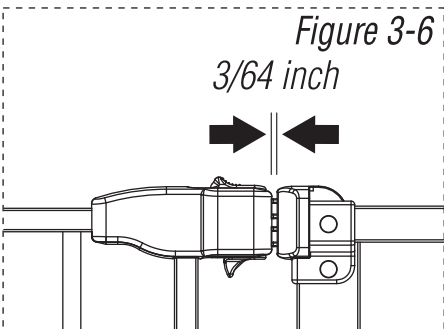

Figure 3-6



Insert all 4 threaded spindle rods into the wall cups (Figure 3-1). Tighten the wheels using the spanner tool. (Figure 3-2 and Figure 3-3) Do not over tighten. It may be necessary to hold the threaded spindle rods while rotating the adjustment wheels to ensure that the entire unit does not rotate while installing the gate.

NOTE if your door latch is not properly engaging with the receiving component, ensure that your gate is level, mounted properly and that you have not over-tightened the adjustment wheels.

NOTE The gap between the gate and the wall should not exceed more than **2.5 inch** on either side (Figure 3-4 and 3-5)

If the gate has been installed properly the gap between the door latch and frame should now be closed (Figure 3-6)

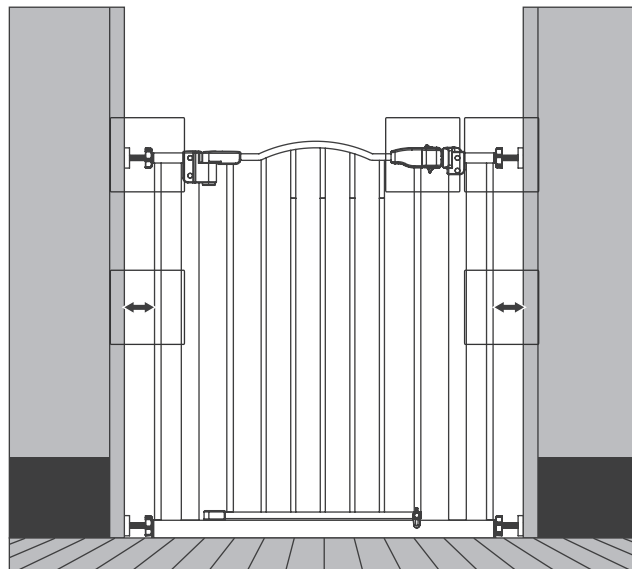

OPERATING THE DOOR LATCH

Figure 4-1

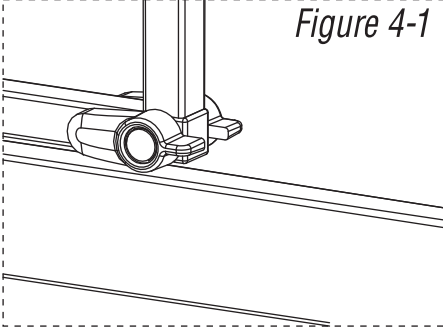

To Open - Ensure that the base locks at the bottom of the gate door are in the horizontal position, (Figure 4-1) then slide the top and bottom levers toward the door and swing open. (Figure 4-2)

Figure 4-2

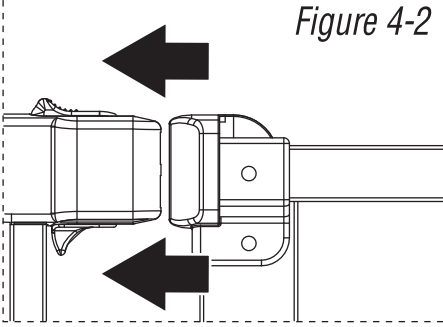

To Close - Pull the door shut and ensure that the door latch on top closes and then place the lock at the bottom of the gate down on the side occupied by the child, Gate will swing both ways unless one of the swing stops is down. Gate will not swing at all if both swing stops are down. (Figure 4-3)

Figure 4-3

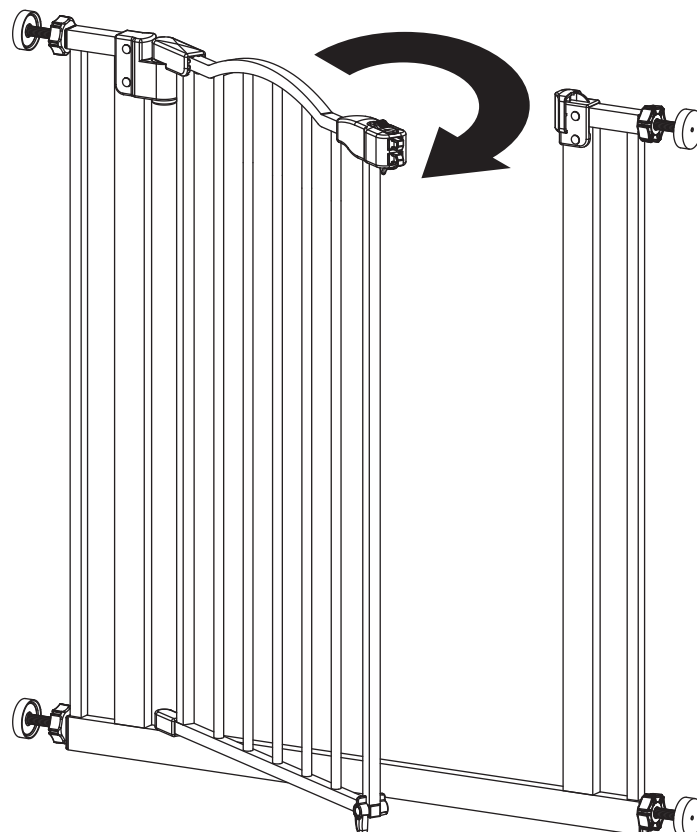
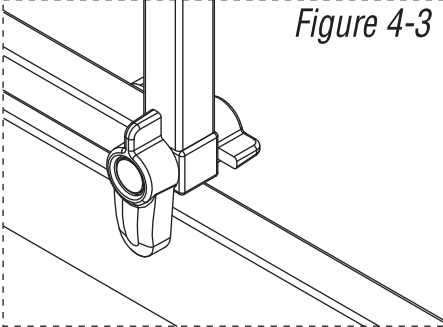

AUTO CLOSE LOCK

Figure 5-1

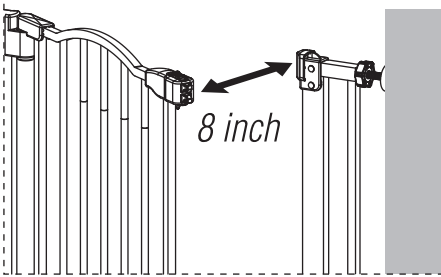

Once the gate is opened, it can close up automatically and lock up.

When the opening width of the gate is **8 inch**, the gate has the function of Automatic Closing (Figure 5-1).

Figure 5-2

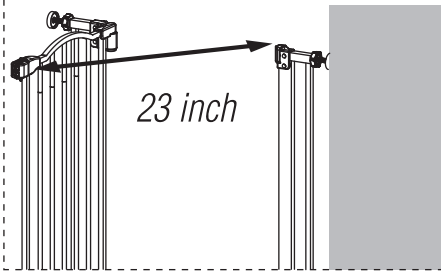

NOTE When the gate opening width is greater than **23 inch**, the gate will be normally open. (Figure 5-2)

USE AT THE TOP OF STAIRS

Figure A

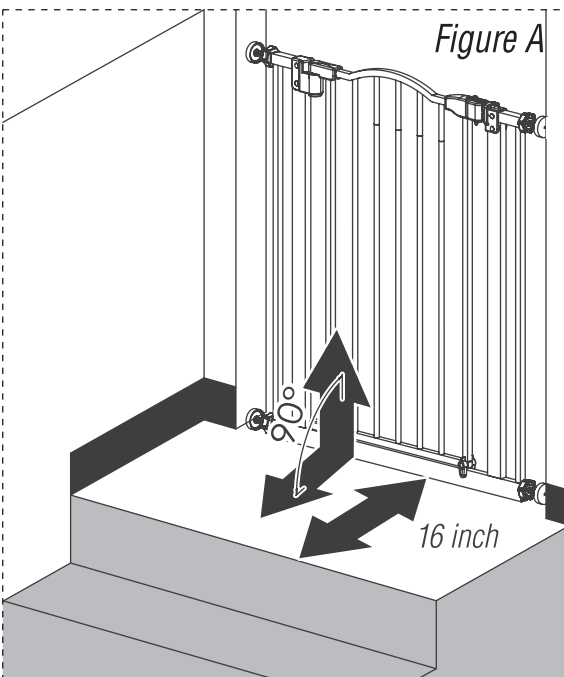

If the gate is used at the top of stairs, we recommend the safe distance to the 1st step is at least 16 inch. (Figure A)

Using the wall cups will affix your gate more firmly in the doorway or opening.

ADDING A GATE EXTENSION

Figure 6-1

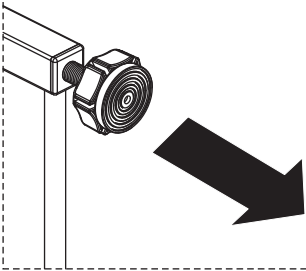

Remove the top and bottom threaded spindle rods.(Figure 6-1)

Figure 6-2

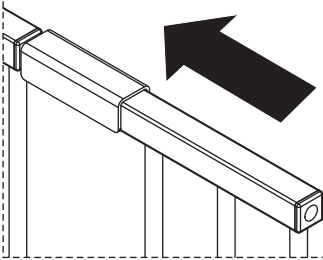

Assemble the gate and extension as illustrated (Figure 6-2 and 6-3). Reposition the gate and fit in accordance with the gate fitting instructions.

Figure 6-3

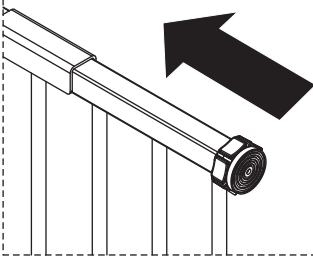

NOTE: It is preferable to install any extensions on the hinge side of the gate.

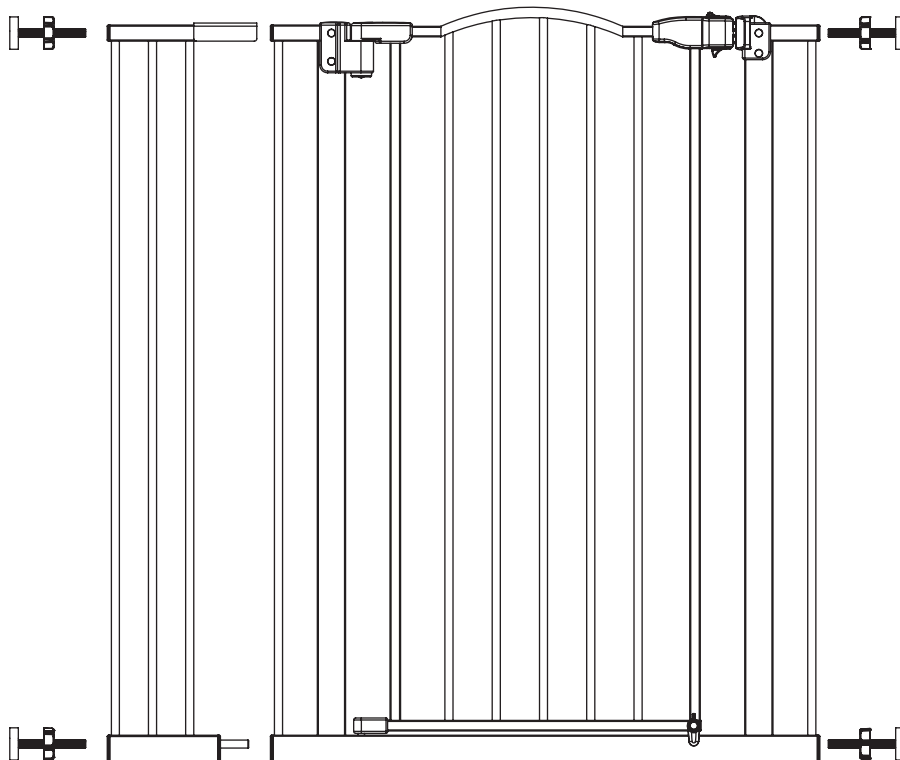

REMOVING YOUR GATE FROM THE WALL

To remove your gate from the wall, rotate the adjustment wheels on each of the (4) threaded spindle rods to depressurize the gate from its doorway or opening. Then, gently pull or push the gate free from its doorway or opening.

CARE AND MAINTENANCE

Periodically check the gate for signs of damage, wear, or missing components.

Do not use if any part is missing, worn or damaged.

Check the gate regularly to ensure all the hardware and mountings are tightened. Do not use abrasive cleaners or bleach. Clean by sponging with warm water and a mild detergent.

IMPORTANTE

- ☒ Un'installazione incorretta potrebbe causare l'instabilità o la disgiunzione del cancello dalla porta.
- ☒ I blocchi alla base devono essere utilizzati sempre, su entrambi i lati del cancello.
- ☒ Questo prodotto non è in grado di prevenire necessariamente tutti gli incidenti.
- ☒ Controllare regolarmente il cancello per verificare se tutta la bulloneria e gli elementi di fissaggio sono stretti in sicurezza.
- ☒ Non utilizzare se mancano alcuni componenti o sono danneggiati.
- ☒ **INTERROMPERE** l'utilizzo quando il bambino è in grado scavalcare o rimuovere il cancello.
- ☒ Le parti aggiuntive o di ricambio devono essere acquistate solo dal produttore o dal distributore.

AVVERTENZE

Dei bambini sono morti o sono stati gravemente feriti in casi in cui i cancelli non sono stati installati in modo sicuro.

Installare e utilizzare SEMPRE i cancelli come indicato utilizzando tutte le parti necessarie.

INSTALLARE le ventose a muro per mantenere il cancello in posizione. Senza le ventose a muro, il bambino può spingere il cancello e uscirne.

INTERROMPERE l'utilizzo quando un bambino può scavalcare o aprire il cancello.

USARE solo con il meccanismo di bloccaggio innestato in sicurezza.

NON usare MAI per tenere il bambino lontano da fonti d'acqua.

NON lasciare MAI il bambino incustodito.

Destinato all'uso con bambini di età compresa tra 6 e 24 mesi. Installare secondo le istruzioni del produttore.

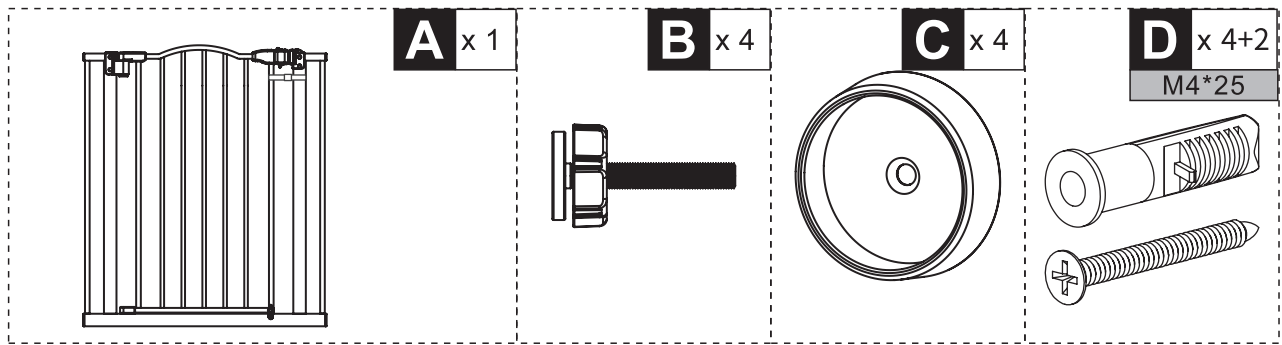

HARDWARE

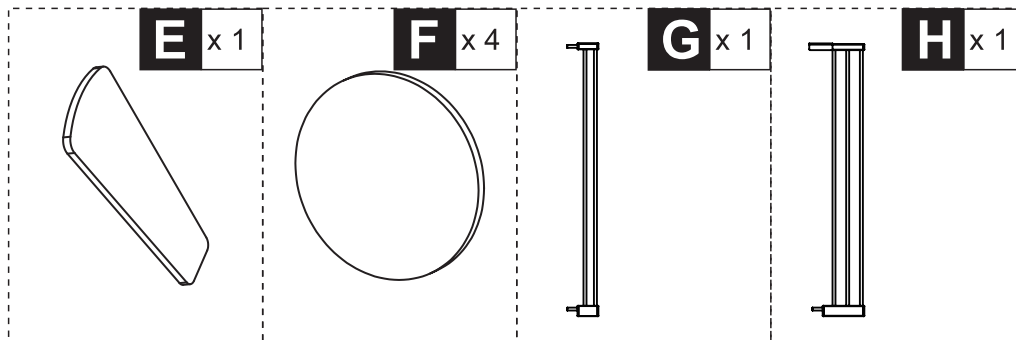

ESTENSIONE E DIMENSIONE MASSIMA

MODELLO NO.	Non esteso	7cm(2.75pollici) Estexo	14cm(5.51pollici) Estexo	DIMENSIONE MASSIMA
D06-094V03	✓	✓	✓	29 - 39pollici
D06-094V07	✓	✓	✓	29 - 39pollici

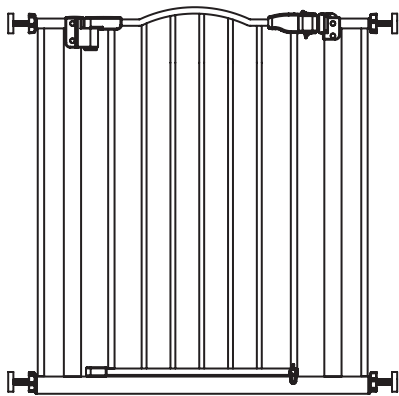

No Extension
74 - 79cm
29 - 31pollici

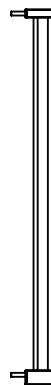

With 7cm(2.75pollici)
81 - 86cm
31.5 - 33.5pollici

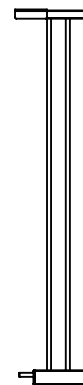

With 14cm(5.51pollici)
88 - 93cm
34.5 - 36.5pollici

INSTALLARE IL VOSTRO CANCELLO



Figura 1-1

Individuare i (4) mandrini filettati (B).
Ruotare le rotelle di regolazione lungo la filettatura, eliminando lo spazio tra la rotella di regolazione e la gomma del piedino (Figura 1-1)

Figura 1-2

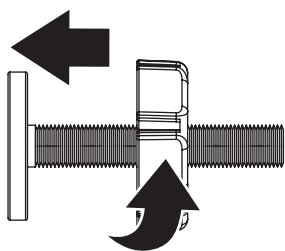
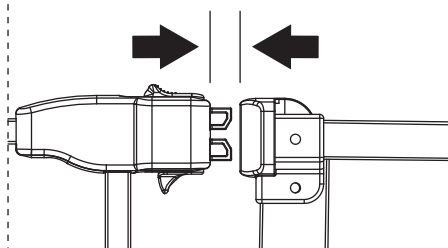

NOTA: È possibile notare un leggero spazio vuoto tra il fermo della porta del cancello e il telaio principale (Figura 1-2).

Figura 1-3

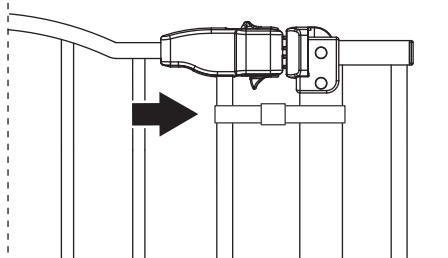

QUESTO NON È UN DIFETTO questo cancello è montato a pressione e questo spazio scomparirà una volta che e' stato stretto nel varco in cui verra' installato.

NON RIMUOVERE LA CERNIERA FINO AL COMPLETAMENTO DELL' INSTALLAZIONE. (Figura 1-3)



Figura 2-1



Inserire i mandrini filettati con le rotelle di regolazione nel foro presente su tutti quattro angoli dei lati del cancello. (Figura 2-1)

Figura 2-2

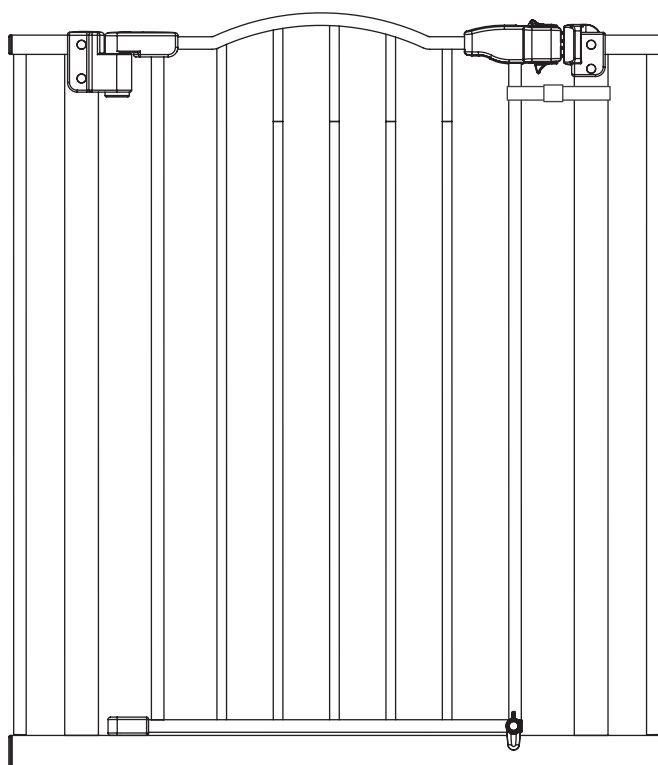
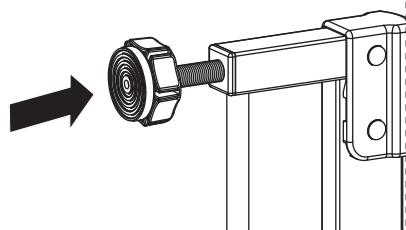
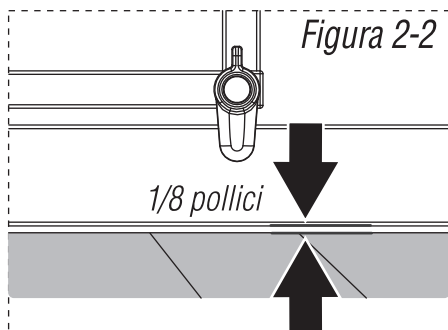

Posizionare il cancello nel varco scelto con la parte inferiore rivolta al pavimento. La distanza tra la parte inferiore del cancello e il pavimento dovrebbe essere inferiore a 1/8 pollice (Figura 2-2).

Figura 2-3

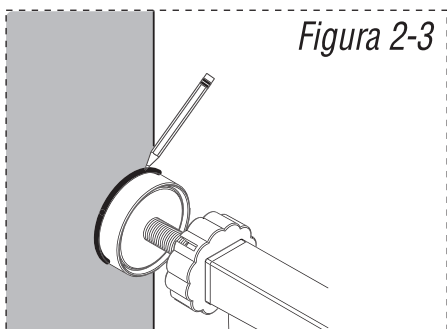

Una volta che siete soddisfatti del posizionamento del cancello, avvitare i mandrini filettati fino a stringere i piedini in gomma sulla superficie del varco assicurandosi che siano a livello (Figura 2-3). Quindi rimuovere il cancello dal varco. Avvitare le 4 ventose a muro usando le viti (Figura 2-4) o fissare le 4 ventose utilizzando gli adesivi in dotazione (Figura 2-5).

Figura 2-4



Figura 2-5



Figura 3-1

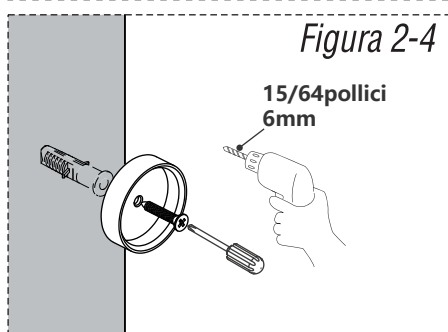

Figura 3-2

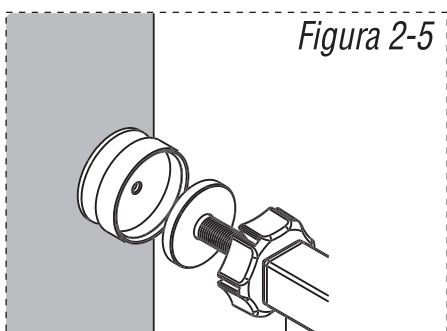

Figura 3-3

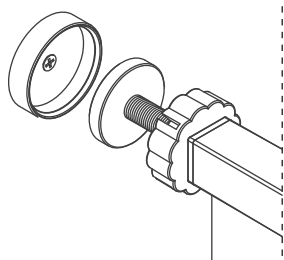

Figura 3-4

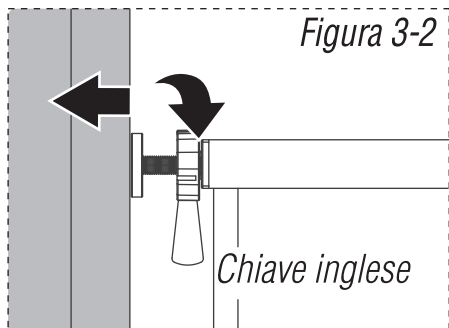

Figura 3-5

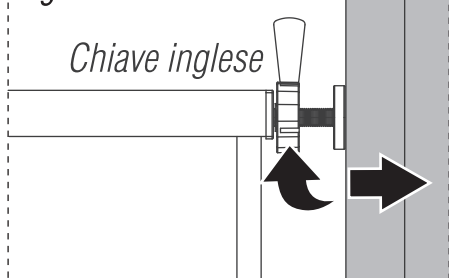

Figura 3-6

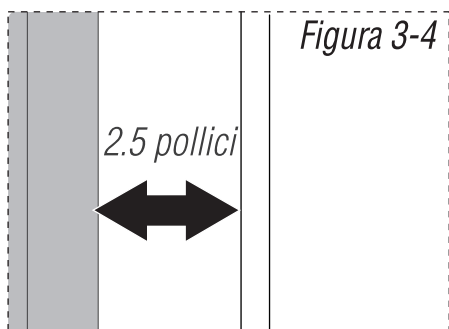

Inserire tutti e 4 i mandrini filettati nelle ventose a muro (Figura 3-1). Stringere le rotelle utilizzando la chiave. (Figura 3-2 e Figura 3-3). Non stringere eccessivamente. Potrebbe essere necessario tenere fermi i mandrini filettati mentre si ruotano le rotelle di regolazione per assicurarsi che l'intera unità non ruoti durante l'installazione del cancello.

NOTA: se il fermo della porta non si innesta correttamente con il punto di arrivo, assicurarsi che il cancello sia a livello, che sia montato correttamente e di non aver stretto eccessivamente le rotelle di regolazione.

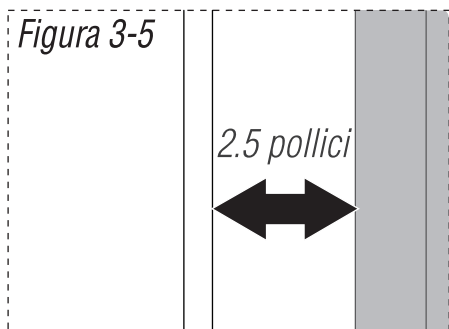
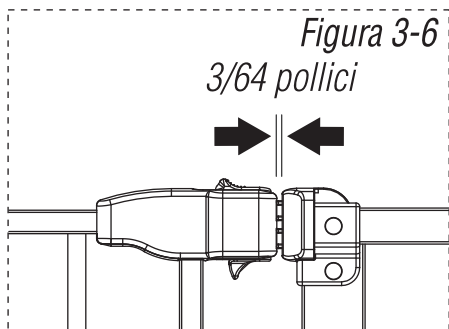
NOTA: Lo spazio tra il cancello e il muro non deve superare i 2,5 pollici su entrambi i lati (Figura 3-4 e 3-5)

Se il cancello è stato installato correttamente, lo spazio tra il fermo della porta e il telaio dovrebbe ora essere completamente chiuso (Figura 3-6)

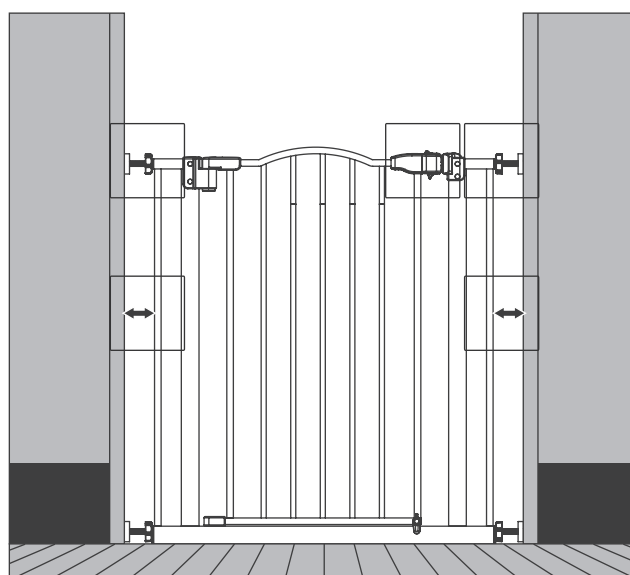

OPERARE IL CHIAVISTELLO

Figura 4-1

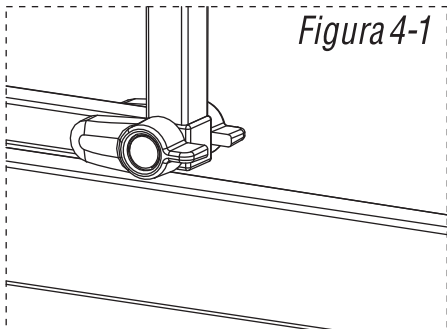

Per aprire - Assicurarsi che i blocchi della base nella parte inferiore della porta del cancello siano in posizione orizzontale (Figura 4-1). quindi far scorrere le leve superiore e inferiore verso lo sportello e aprirlo. (Figura 4-2)

Figura 4-2

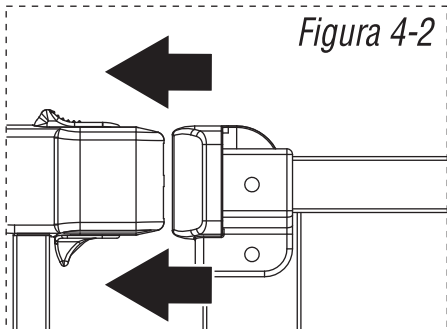

Per chiudere - Chiudere la porta e assicurarsi che il fermo sia rivolto verso l'alto e sia chiuso, quindi posizionare il chiavistello nella parte inferiore del cancello sul lato occupato dal bambino, il cancello oscillerà in entrambe le direzioni a meno che uno dei fermi non sia abbassato. Il cancello non oscillerà se entrambi i blocchi sono abbassati (Figura 4-3)

Figura 4-3

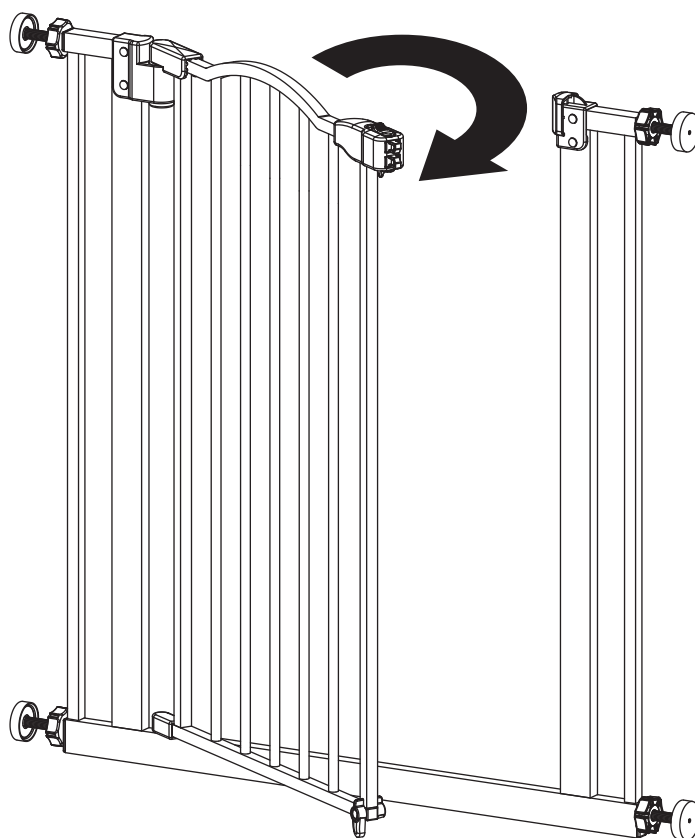
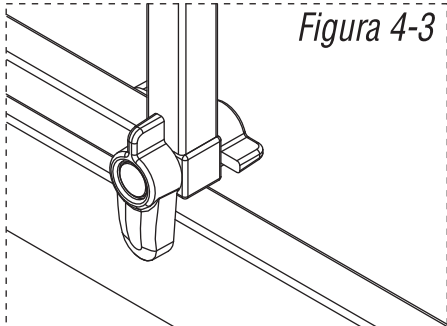

AUTO CHIUSARE LOCK

Figura 5-1

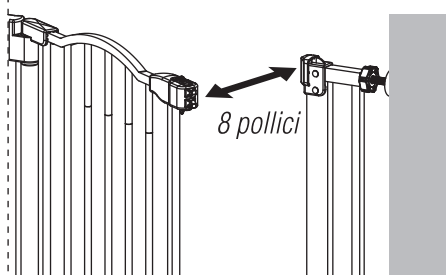

Una volta aperto, il cancello può chiudersi automaticamente e bloccarsi.

Quando la larghezza di apertura del cancello è di **8 pollici**, il cancello si chiuderà automaticamente (Figura 5-1).

Figura 5-2

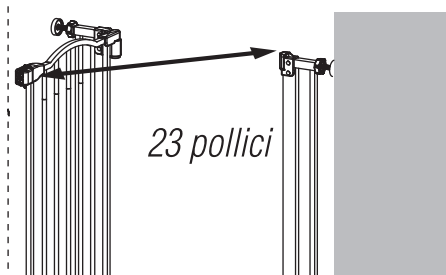

NOTA: Quando la larghezza di apertura del cancello è maggiore di **23 pollici**, il cancello si aprirà normalmente. (Figura 5-2)

USO IN CIMA ALLE SCALE

Figura A

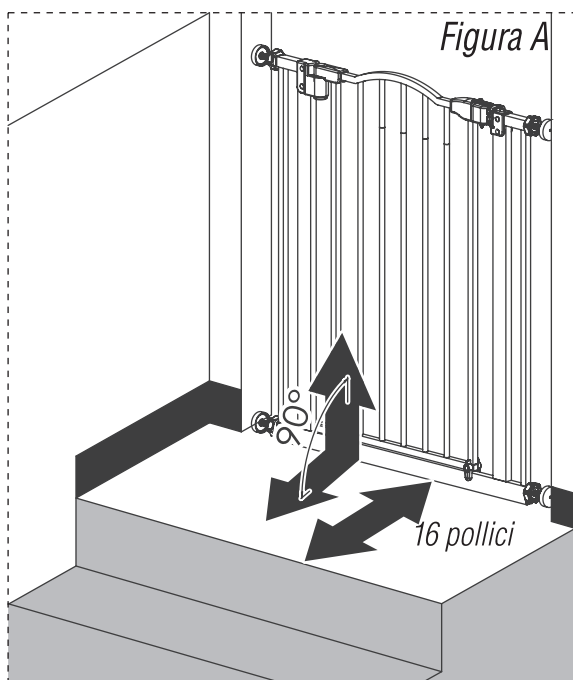

Se il cancello viene utilizzato in cima alle scale, raccomandiamo che la distanza del cancello dal primo gradino sia di almeno 16 pollici. (Figura A).

L'utilizzo delle ventose a muro fisserà il vostro cancello più saldamente alla porta o al varco.

AGGIUNGERE UN' ESTENSIONE AL CANCELLO

Figura 6-1



Figura 6-2



Figura 6-3

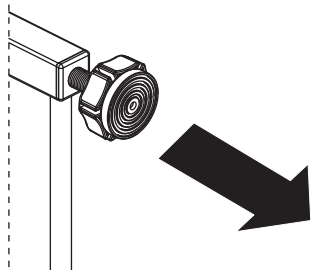

Rimuovere la parte superiore e inferiore dei mandrini filettati. (Figura 6-1)

Montare il cancello e l'extensione come illustrato (Figura 6-2 e 6-3). Riposizionare il cancello perche' si adatti secondo le istruzioni di montaggio.

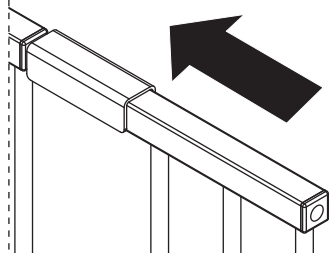
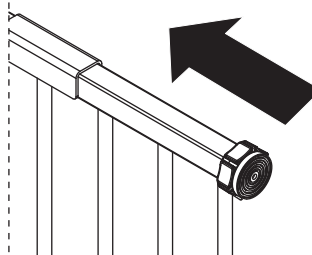
NOTA: è preferibile installarne uno qualsiasi estensione sul lato con i cardini del cancello.

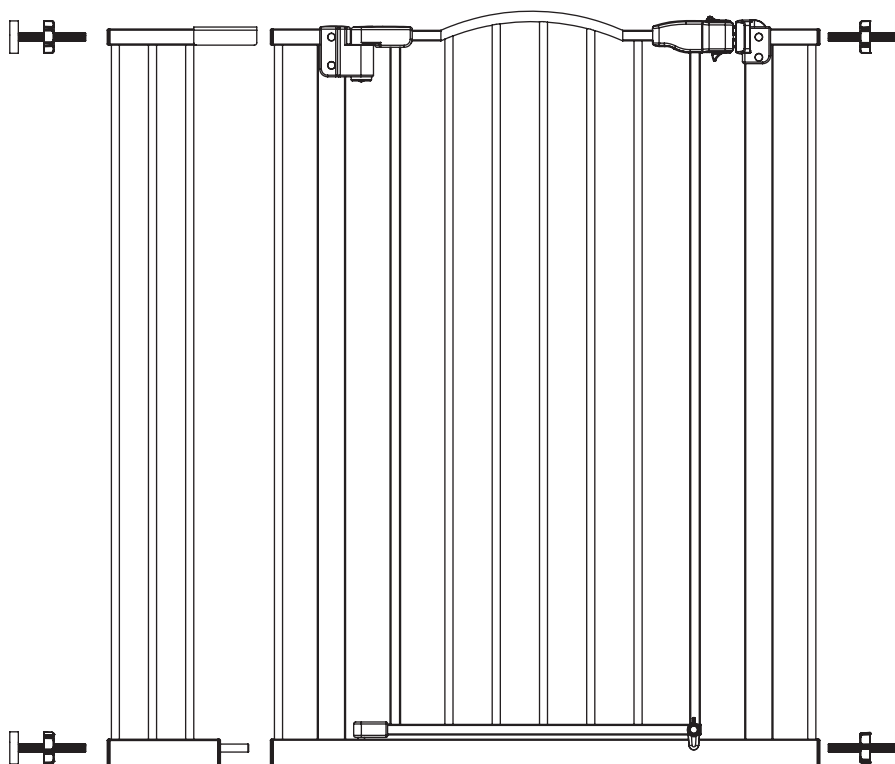

RIMUOVERE IL CANCELLO DAL MURO

IT

Per rimuovere il cancello dal muro, ruotare le rotelle di regolazione su ciascuno dei (4) mandrini filettati per depressurizzare il cancello dalla sua porta o varco di installazione. infine, tirare o spingere delicatamente il cancello per liberarlo dalla porta o dal varco.

CURA E MANUTENZIONE

Controllare periodicamente il cancello per verificare la presenza di segni di danneggiamento, usura o se mancano dei componenti. Non usare se alcuni parti sono mancante, usurate o danneggiate. Controllare regolarmente il cancello per assicurarsi che tutta la bulloneria e gli elementi di fissaggio siano stretti in sicurezza. Non utilizzare detergenti abrasivi o candeggina. Pulire con una spugna calda, acqua e un detergente delicato.

If you have any questions, please contact our customer care center, Our contact details are below:

US

 001-877-644-9366

 customerservice@aosom.com

Imported by Aosom LLC
27150 SW Kinsman Rd Wilsonville, OR 97070 USA
MADE IN CHINA

If you have any questions, please contact our customer care center, Our contact details are below:

CA

 416-792-6088

 customerservice@aosom.ca

Imported by Aosom Canada Inc.
7270 Woodbine Avenue, Unit 307, Markham,
Ontario Canada L3R 4B9
MADE IN CHINA

Si vous avez la moindre question, veuillez contacter notre centre d'assistance à la clientèle, Nos coordonnées sont les suivantes:

 416-792-6088

 customerservice@aosom.ca

Importé par Aosom Canada Inc.
7270 Woodbine Avenue, unité 307,
Markham, Ontario Canada L3R 4B9
FABRIQUÉ EN CHINE

If you have any questions, please contact our customer care center, Our contact details are below:

UK

 0044-800-240-4004

 enquiries@mhstar.co.uk

IMPORTER ADDRESS:
MH STAR UK LTD
Unit 27, Perivale Park,
Horsenden lane South
Perivale, UB6 7RH
MADE IN CHINA

Si vous avez la moindre question, veuillez contacter notre centre d'assistance à la clientèle, Nos coordonnées sont les suivantes:

FR

 0033-1-84166106

 aosom@mhfrance.fr

Importé par/Fabricant/REP:
MH FRANCE
2 Rue Maurice Hartmann
92130 Issy Les Moulineaux
France
FABRIQUÉ EN CHINE

Wenn Sie Fragen haben, wenden Sie sich bitte an unser Kundendienstzentrum, Unsere Kontaktdaten stehen unten:

DE

 0049-0(40)-88307530

 service@aosom.de

ADRESSE DES IMPORTEURE/Hersteller/REP:
MH Handel GmbH
Wendenstraße 309
D-20537 Hamburg
Germany
IN CHINA HERGESTELLT

In caso di dubbio, si prega di contattare il nostro centro assistenza clienti, I nostri dettagli di contatto sono di seguito:

IT

 0039-0249471447

 clienti@aosom.it

IMPORTATO DA/Produttore/REP:
AOSOM Italy srl
Centro Direzionale Milanofiori
Strada 1 Palazzo F1
20057 Assago (MI)
P.I.: 08567220960
FATTO IN CINA

Si tiene alguna pregunta, comuníquese con nuestro Centro de Atención al Cliente, Nuestros datos de contacto son los siguientes:

ES

 0034-931294512

 atencioncliente@aosom.es

IMPORTADOR/Fabricante/REP:
SPANISH AOSOM, S.L.
C/ROC GROS, N°15.08550, ELS HOSTALETES DE
BALENYÀ, SPAIN.
B66295775
HECHO EN CHINA

Se tiver alguma dúvida, por favor contacte o nosso Centro de Atendimento ao Cliente, Os nossos dados de contacto são os seguintes:

PT

 0034-931294512

 info@aosom.pt.

IMPORTADOR/Fabricante/REP:
SPANISH AOSOM, S.L.
C.ROC GROS N.15, 08550. ELS HOSTALETES DE
BALENYÀ
FEITO NA CHINA



FR

**DONNEZ
OU
RECYCLEZ**



OU



OU



ASSOCIATION

LIVRAISON

DÉCHÈTERIE

Adresses sur quefairedemesdechets.fr