

# PawHut

IN231100038V03\_GL

**D00-190V00\_D00-190V01**



**EN\_IMPORTANT, RETAIN FOR FUTURE REFERENCE: READ CAREFULLY.**

**FR\_IMPORTANT: A LIRE ATTENTIVEMENT ET À CONSERVER POUR CONSULTATION  
ULTÉRIEURE.**

**ES\_IMPORTANTE, LEA Y GUARDE PARA FUTURAS REFERENCIAS.**

**PT\_IMPORTANTE, RETER PARA REFERÊNCIA FUTURA: LEIA ATENTAMENTE.**

**DE\_WICHTIG! SORGFÄLTIG LESEN UND FÜR SPÄTER NACHSCHLAGEN AUFBEWAHREN.**

**IT\_IMPORTANTE! CONSERVARE IL PRESENTE MANUALE PER FUTURO RIFERIMENTO E  
LEggerlo ATTENTAMENTE.**

**WARNING:Keep Away From Fire**

- 1.Please read this instruction carefully before use and keep it properly for future reference. If you do not follow this instruction, the safety of pets may be affected.
- 2.Do not leave the caregiver while the product is in use.
- 3.Do not use accessories not provided by the manufacturer.
- 4.Any load attached to the handle will affect the stability of the pet stroller.
- 5.Ensure that all the locking devices are assembled before using the pet stroller.
- 6.Pets must use restraints when using.
- 7.Do not use the pet stroller in rough areas, near stoves and other dangerous areas.
- 8.Avoid use or storage in damp, cold or high temperature environment and keep away from fire or strong heat source.
- 9.Do not use it to put dangerous animals which are aggressive and destructive.

**Maintenance and Care**

Please check and maintain the pet stroller frequently. The cloth cover cannot be dipped and washed. When the cloth cover is cleaned, please use a brush and other cleaning instruments to clean the dirt.

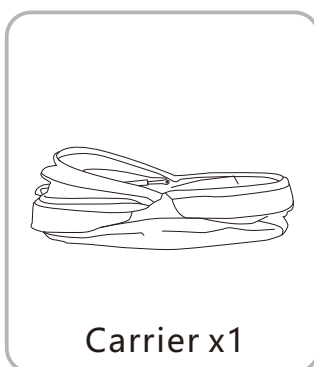
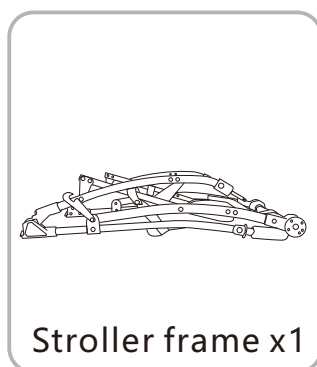
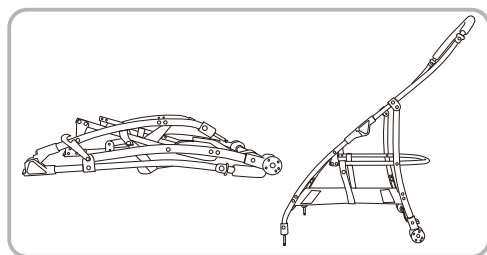
**Parts****Directions for use****1.Unfolding frame**

Take out the frame, hold the handlebar with both hands and lift it up until a click is heard which means the frame is fully open.

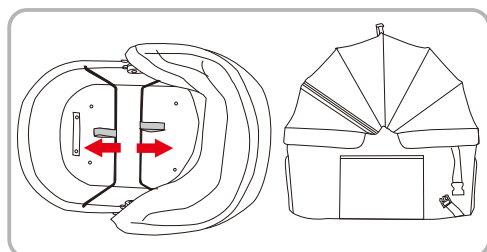
**2.Unfolding pet carrier**

Take out the pet carrier, press the bottom plate with one hand, and pull the belt on the iron support with the other hand in the direction of the arrow 45 degrees until the iron support on both sides is completely stuck into the slot. Reverse operation to fold it.

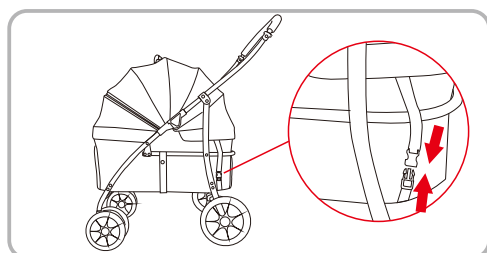
**3.Installing pet carrier**

First, glue the velcro at the front end of the basket to the bottom fabric of the frame, and then fasten the buckle of the bottom fabric of the basket around the frame tube. Reverse operation to fold it.

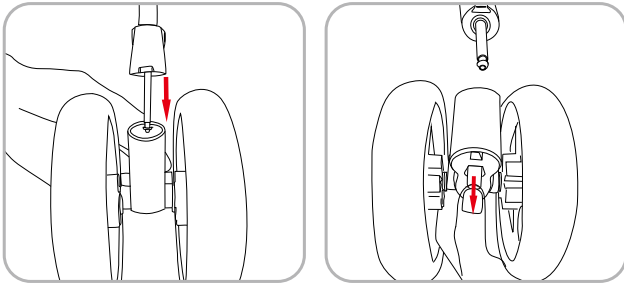

**4. Usage of front wheels**

Insert the front wheel set into the front wheel seat, it is installed when hear "Click".

Press the buckle on the front wheel seat with your hand and pull it down, then the front wheel set is removed.

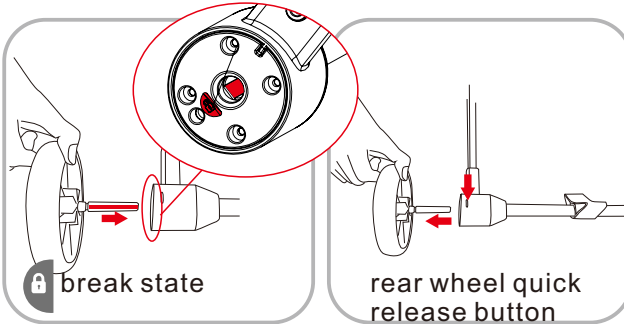

**5. Usage of rear wheel**

Install: In the break state, Align the flat form of the wheel axle with the rear wheel locking direction and insert it in parallel until you hear a click.

When you need to disassemble, press and hold the rear wheel quick release button and pull it out at the same time.

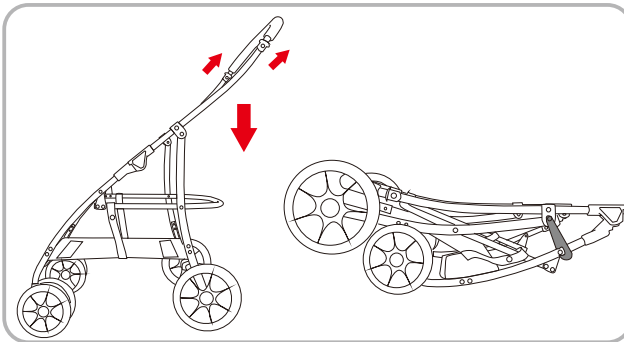

**6. Folding frame**

In the braking state, take out the carrier, first lift up the two sides of the folding keys, hold the handle to press down, the frame can be folded, finally hang the hook.

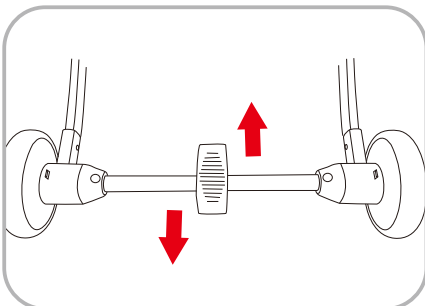

**7. Press down the brakes on both sides, the brake works.**

Conversely, it can be released.

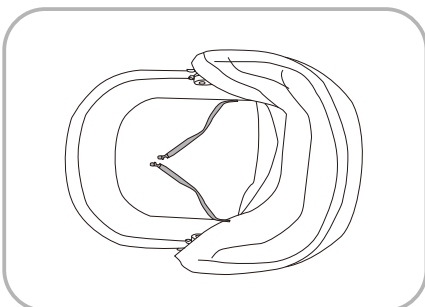

**8. For pet safety belts**

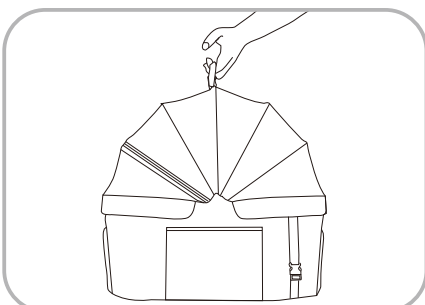

**9. Lift by hand**

**AVERTISSEMENT : À Garder à l'Écart Du Feu**

1. Prière de lire attentivement ces instructions avant l'utilisation et de les conserver pour s'y référer ultérieurement. Le non-respect de ces instructions peut affecter la sécurité des animaux domestiques.
2. Le gardien ne doit pas s'absenter pendant l'utilisation de l'appareil.
3. Ne pas utiliser d'accessoires non fournis par le fabricant.
4. La stabilité de la poussette est affectée par toute charge fixée à la poignée.
5. S'assurer que tous les dispositifs de verrouillage sont assemblés avant d'utiliser la poussette pour animaux.
6. Les animaux domestiques doivent être attachés lors de l'utilisation.
7. Ne pas utiliser la poussette dans des endroits rugueux, à proximité de foyers ou d'autres endroits dangereux.
8. Éviter d'utiliser ou de ranger la poussette dans un environnement humide, froid ou à haute température et la tenir éloignée du feu ou d'une source de chaleur intense.
9. La poussette ne doit pas être utilisée pour transporter des animaux dangereux, agressifs et nuisibles.

**Maintenance et Entretien**

La poussette doit être vérifiée et entretenue fréquemment. La housse en tissu ne doit pas être trempée ni lavée. Lorsque la housse en tissu doit être nettoyée, prière d'utiliser une brosse et d'autres instruments de nettoyage pour enlever la saleté.

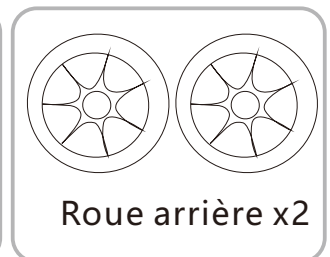
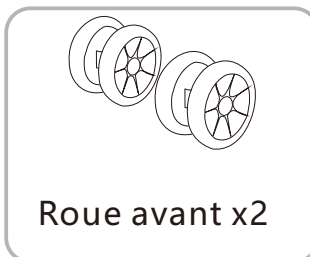
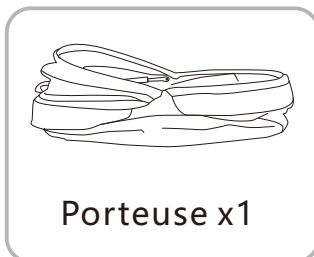
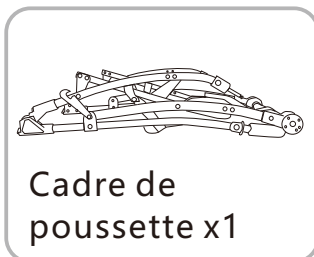
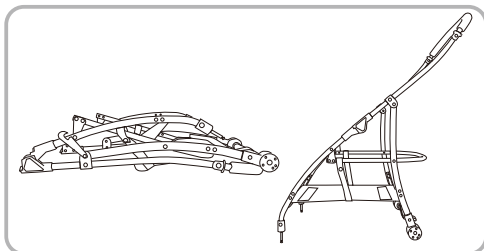
**Pièces****Directions for use****1. déplier le cadre**

Sortez le cadre, tenez le guidon à deux mains et soulevez-le jusqu'à ce que vous entendiez un déclic, ce qui signifie que le cadre est complètement ouvert.

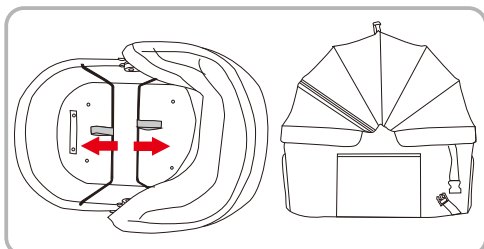
**2. déplier la cage de transport**

Sortez la cage de transport, appuyez sur la plaque inférieure d'une main et tirez la courroie du support en fer de l'autre main dans le sens de la flèche à 45 degrés jusqu'à ce que le support en fer des deux côtés soit complètement coincé dans la fente.

Inverser l'opération pour le plier.

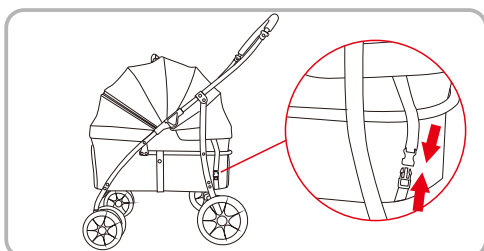
**3. Installation de la cage de transport**

Tout d'abord, collez le velcro à l'extrémité avant du panier sur le tissu inférieur du cadre, puis fixez la boucle du tissu inférieur du panier autour du tube du cadre.

Inverser l'opération pour le plier.

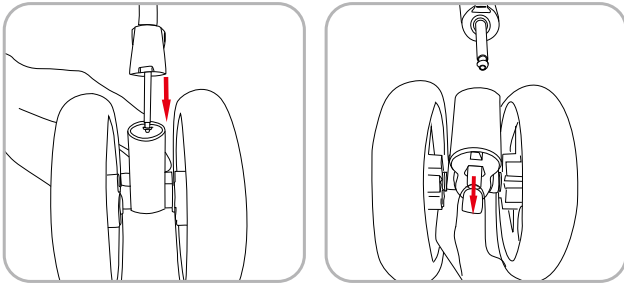

4. Utilisation des roues avant  
 Insérez l'ensemble de roues avant dans le siège des roues avant, il est installé lorsque vous entendez "Click". Appuyer avec la main sur la boucle du siège de la roue avant et la tirer vers le bas, puis retirer le train de roues avant.

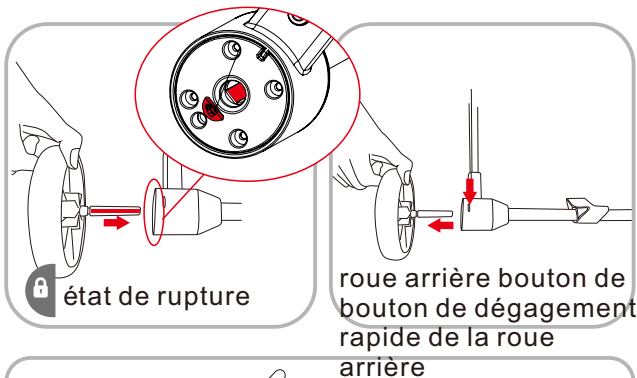

5. utilisation de la roue arrière  
 Installation: En état de rupture, alignez la forme plate de l'axe de la roue avec le sens de verrouillage de la roue arrière  et insérez-la parallèlement jusqu'à ce que vous entendiez un clic.  
 Pour démonter la roue arrière, appuyez sur le bouton de déverrouillage rapide de la roue arrière et tirez-la en même temps.

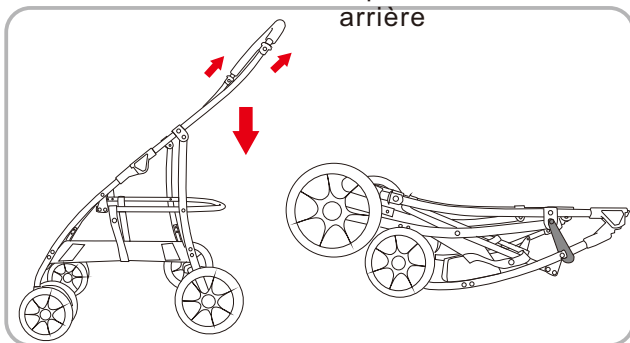

#### 6. cadre pliant

En état de freinage, retirez le support, soulevez d'abord les deux côtés des clés de pliage, tenez la poignée pour appuyer vers le bas, le cadre peut être plié, enfin accrochez le crochet.

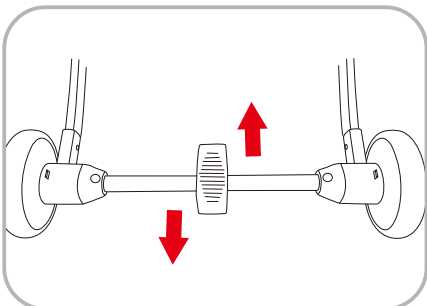

7. appuyez sur les freins des deux côtés, le frein fonctionne. Inversement, il peut être desserré.

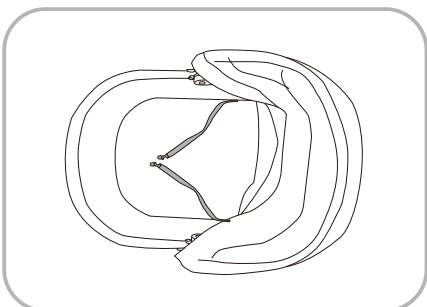

8. pour les ceintures de sécurité des animaux de compagnie

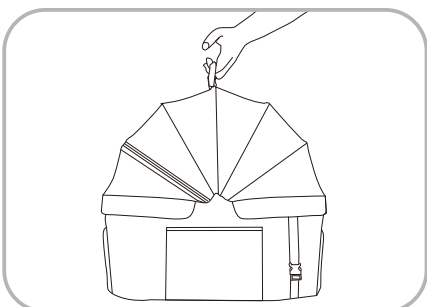

9. soulever à la main

**ADVERTENCIA: Mantener alejado del fuego**

1. Por favor, lea atentamente estas instrucciones antes de usar el aparato y guárdelas para futuras consultas. Si no sigue estas instrucciones, la seguridad de las mascotas puede verse afectada.
2. No deje al cuidador mientras el producto está en uso.
3. No utilice accesorios no proporcionados por el fabricante.
4. Cualquier carga fijada al mango afectará la estabilidad del cochecito para mascotas.
5. Asegúrese de que todos los dispositivos de bloqueo estén montados antes de usar la silla de paseo para mascotas.
6. Los animales domésticos deben ir sujetos cuando se esté usando el producto.
7. No use el cochecito para mascotas en zonas abruptas, cerca de estufas y otras zonas peligrosas.
8. Evite el uso o el almacenamiento en ambientes húmedos, fríos o con altas temperaturas y manténgalo alejado del fuego o de fuentes de calor fuertes.
9. No lo utilice para colocar animales peligrosos que sean agresivos y destructivos.

**Mantenimiento y Cuidado**

Por favor, compruebe y mantenga el cochecito para mascotas con frecuencia. La funda de tela no se puede sumergir ni lavar. Cuando se limpie la cubierta de tela, por favor, utilice un cepillo y otros instrumentos de limpieza para limpiar la suciedad.

**Piezas**

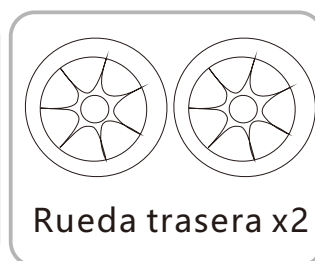
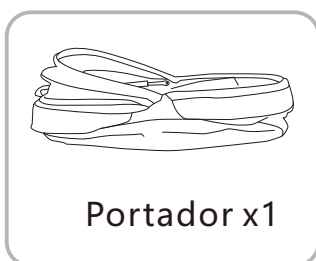

**Instrucciones de uso**

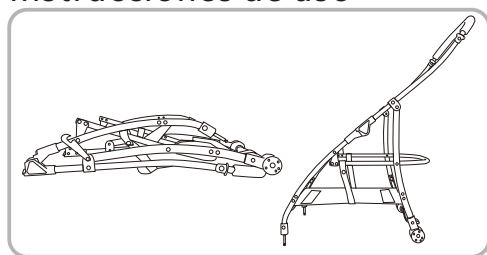

**1. Despliegue del cuadro**

Saque el cuadro, sujete el manillar con ambas manos y levántelo hasta que se oiga un clic que significa que el cuadro está completamente abierto.

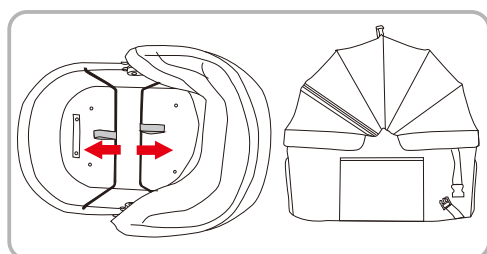

**2. Despliegue del transportín**

Saque el transportín para mascotas, presione la placa inferior con una mano y tire de la correa del soporte de hierro con la otra mano en la dirección de la flecha 45 grados hasta que el soporte de hierro de ambos lados quede completamente encajado en la ranura. Invierta la operación para plegarlo.

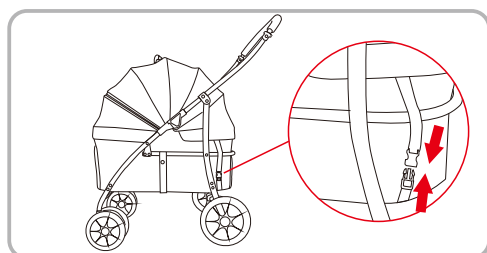

**3. Instalación de la cesta para mascotas**

En primer lugar, pegue el velcro del extremo delantero de la cesta a la tela inferior del armazón y, a continuación, fije la hebilla de la tela inferior de la cesta alrededor del tubo del armazón.

Invierta la operación para plegarlo.

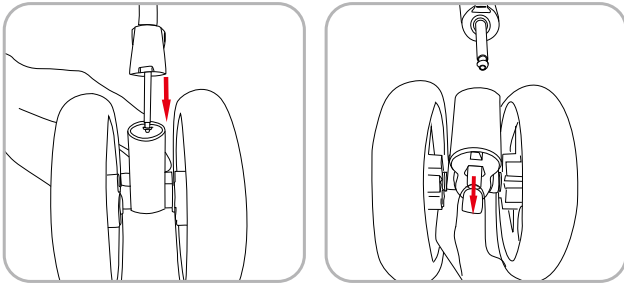

**4. Uso de las ruedas delanteras**  
 Inserte el juego de ruedas delanteras en el asiento de las ruedas delanteras, estará instalado cuando oiga "Click". Apriete la hebilla del asiento de la rueda delantera con la mano y tire de ella hacia abajo, entonces se retira el juego de ruedas delanteras.

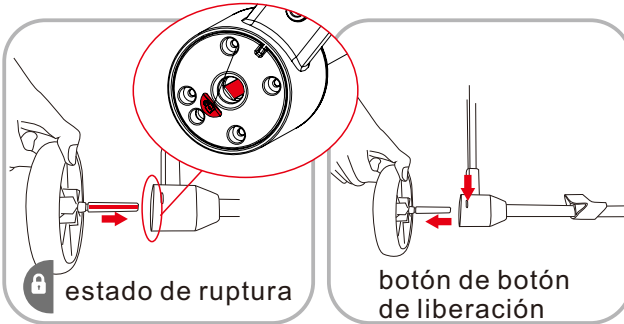

**5. Uso de la rueda trasera**  
**Instalación:** En estado de rotura, alinee la forma plana del eje de la rueda con la dirección de bloqueo de la rueda trasera  e insértela en paralelo hasta que oiga un clic. Cuando necesite desmontarla, mantenga pulsado el botón de liberación rápida de la rueda trasera y tire de ella al mismo tiempo.

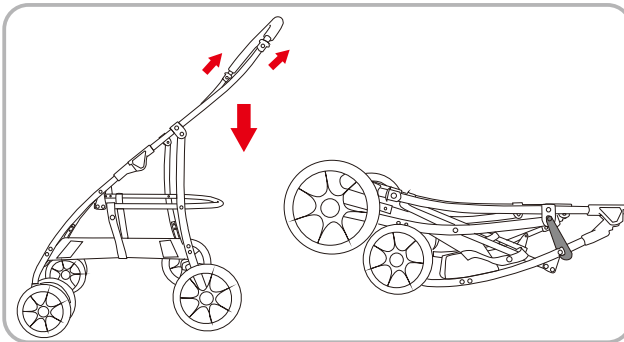

**6. Marco plegable**  
 En el estado de frenado, saque el portador, primero levante los dos lados de las teclas de plegado, sujete el mango para presionar hacia abajo, el marco se puede plegar, finalmente cuelgue el gancho.

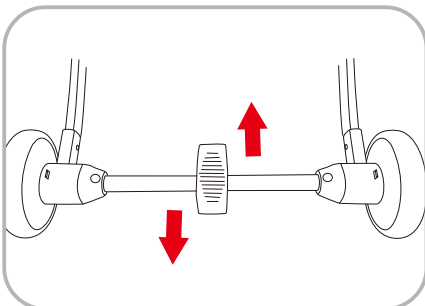

**7. Presione los frenos a ambos lados, el freno funciona.**  
 A la inversa, se puede soltar.

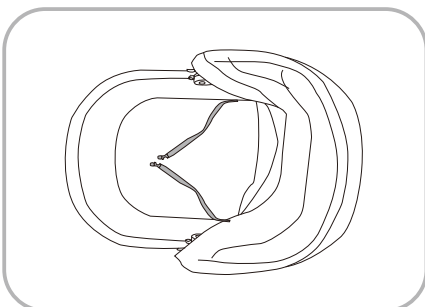

**8. Para cinturones de seguridad para mascotas**

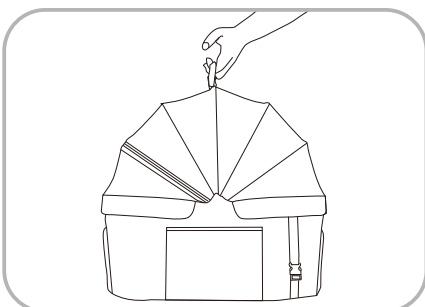

**9. Levantar a mano**

**AVISO: Mantenha-se Longe do Fogo**

1. Por favor leia esta instrução cuidadosamente antes de usar e guarde-a devidamente para referência futura. Se não seguir estas instruções, a segurança dos animais de estimação pode ser afetada.
2. Não deixe o prestador de cuidados enquanto o produto estiver em uso.
3. Não utilize acessórios não fornecidos pelo fabricante.
4. Qualquer carga presa à pega afetará a estabilidade do carrinho do animal.
5. Certifique-se de que todos os dispositivos de bloqueio estão montados antes de usar o carrinho de passeio para animais domésticos.
6. Animais de estimação devem usar trelas.
7. Não use o carrinho de passeio em áreas ásperas, perto de fogões e outras áreas perigosas.
8. Evitar o uso ou armazenamento em ambientes húmidos, frios ou de alta temperatura e manter longe de fogo ou fonte de calor forte.
9. Não o utilize para colocar animais perigosos que sejam agressivos e destrutivos.

**Manutenção e Cuidados**

Por favor, verifique e mantenha o carrinho de passeio frequentemente. A cobertura do pano não pode ser mergulhada e lavada. Quando a cobertura do pano for limpa, por favor use uma escova e outros instrumentos de limpeza para limpar a sujidade.

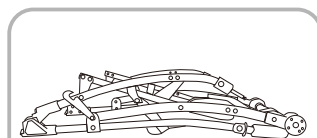
**Partes**

Estrutura do carrinho de bebé x1



Transportador x1

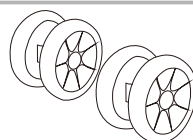

Roda dianteira x2

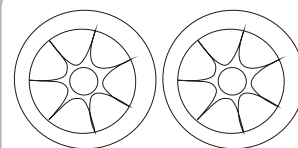

Roda traseira x2

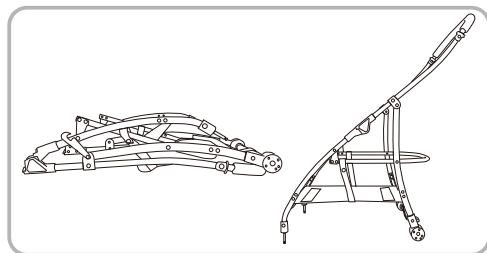
**Modo de utilização****1. desdobrar o quadro**

Retire o quadro, segure o guiador com as duas mãos e levante-o até ouvir um clique, o que significa que o quadro está totalmente aberto.

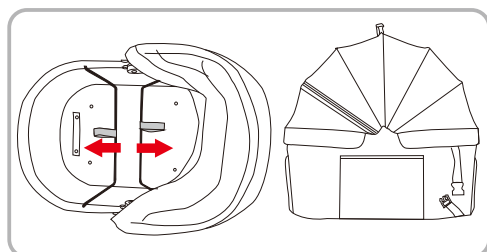
**2) Desdobrar o porta-animais**

Retire o porta-animais, pressione a placa inferior com uma mão e, com a outra mão, puxe a correia do suporte de ferro na direção da seta a 45 graus até que o suporte de ferro de ambos os lados fique completamente preso na ranhura. Reverter a operação para o dobrar.

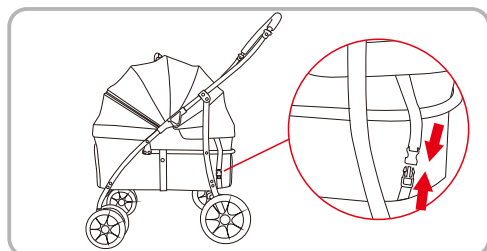
**3. Instalar o porta-animais**

Primeiro, cole o velcro na parte da frente do cesto ao tecido inferior da estrutura e, em seguida, aperte a fivela do tecido inferior do cesto à volta do tubo da estrutura. Reverter a operação para o dobrar.



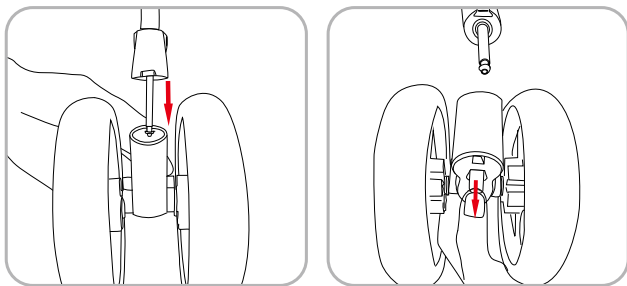

4. Utilização das rodas dianteiras  
Introduzir o conjunto da roda dianteira no banco da roda dianteira; está instalado quando se ouve um "clique". Prima a fivela do banco da roda dianteira com a mão e puxe-a para baixo, depois o conjunto da roda dianteira é retirado.

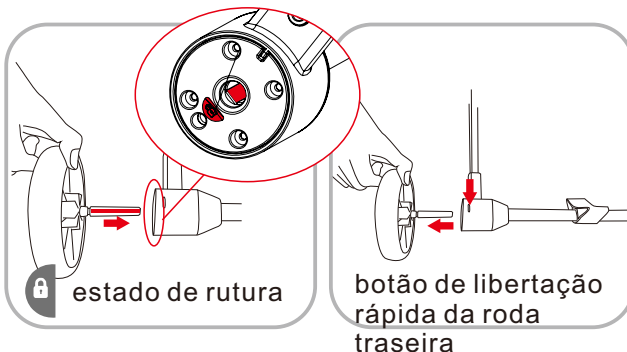

5. Utilização da roda traseira  
Instalar: No estado de pausa, alinhar a forma plana do eixo da roda com a direção de bloqueio da roda traseira  e inseri-la em paralelo até ouvir um clique. Quando precisar de desmontar, prima e mantenha premido o botão de libertação rápida da roda traseira e puxe-o ao mesmo tempo.

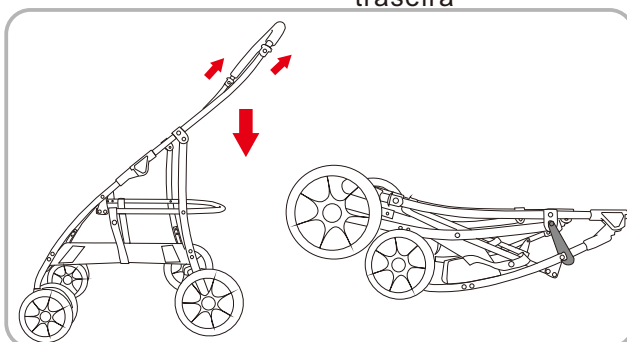

6. quadro dobrável  
No estado de travagem, retire o suporte, levante primeiro os dois lados das chaves de dobragem, segure a pega para pressionar para baixo, a estrutura pode ser dobrada, finalmente pendure o gancho.

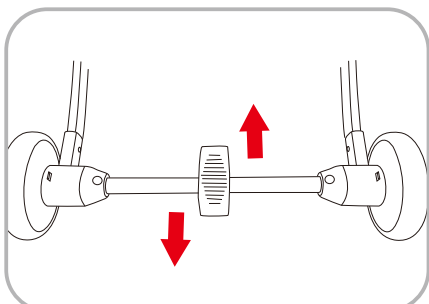

7. pressionar os travões de ambos os lados, o travão funciona. Por outro lado, pode ser libertado.

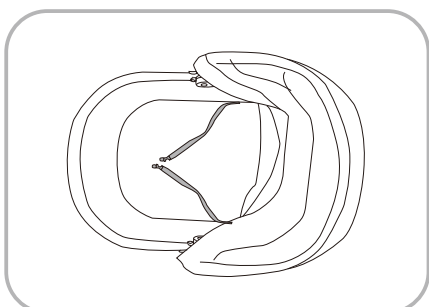

8. para cintos de segurança para animais de estimação

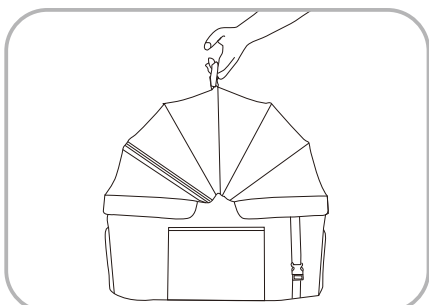

9. levantar à mão

**WARNUNG: Von Feuer fernhalten**

1. Bitte lesen Sie diese Anweisung sorgfältig durch und bewahren Sie sie zum späteren Nachschlagen auf. Wenn Sie diese Anweisung nicht befolgen, kann die Sicherheit von Haustieren beeinträchtigt werden.
2. Während der Verwendung des Produkts darf sich die Betreuungsperson nicht entfernen.
3. Verwenden Sie kein Zubehör, das nicht vom Hersteller bereitgestellt wird.
4. Jede an der Lenkstange befestigte Last beeinträchtigt die Stabilität des Hundebuggys.
5. Stellen Sie sicher, dass alle Verriegelungsvorrichtungen vor der Verwendung des Hundebuggys montiert sind.
6. Haustiere müssen bei der Verwendung angeschnallt sein.
7. Verwenden Sie den Hundebuggy nicht in rauen Gegenden, in der Nähe von Öfen oder anderen gefährlichen Bereichen.
8. Verwenden oder lagern Sie ihn nicht in feuchten, kalten oder heißen Umgebungen und halten Sie ihn von Feuer oder starken Wärmequellen fern.
9. Verwenden Sie ihn nicht für gefährliche Tiere, die aggressiv und zerstörerisch sind.

**Wartung und Pflege**

Bitte überprüfen und warten Sie den Hundebuggy regelmäßig. Das Verdeck kann nicht getaucht und gewaschen werden. Wenn Sie das Verdeck reinigen, verwenden Sie bitte eine Bürste und andere Reinigungsmittel, um den Schmutz zu entfernen.

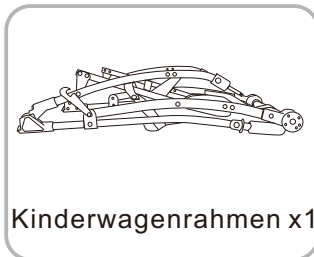
**Teile**

Kinderwagenrahmen x1

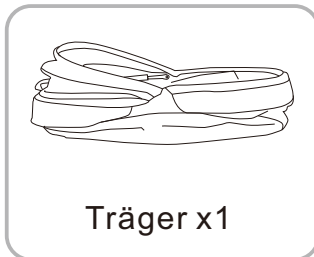

Träger x1



Vorderrad x2

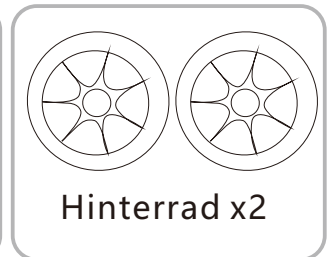

Hinterrad x2

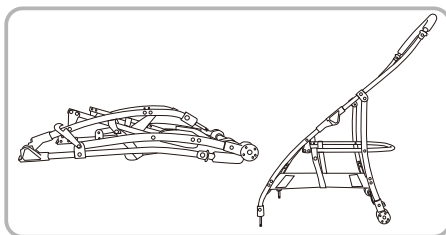
**Gebrauchsanweisung****1. den Rahmen aufklappen**

Nehmen Sie den Rahmen heraus, halten Sie den Lenker mit beiden Händen fest und heben Sie ihn an, bis ein Klicken zu hören ist, was bedeutet, dass der Rahmen vollständig geöffnet ist.

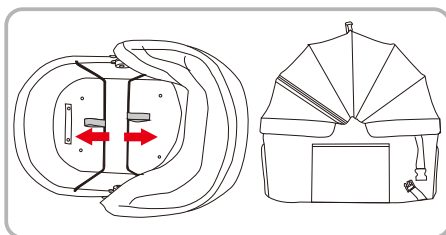
**2. aufklappen des Tiertransporters**

Nehmen Sie den Tiertransporter heraus, drücken Sie mit einer Hand auf die Bodenplatte und ziehen Sie mit der anderen Hand den Gurt an der Bügelhalterung in Pfeilrichtung um 45 Grad, bis die Bügelhalterung auf beiden Seiten vollständig in den Schlitz eingesteckt ist. Zum Zusammenklappen in umgekehrter Reihenfolge vorgehen.

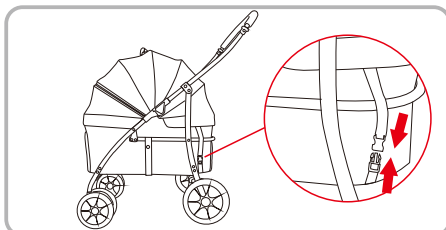
**3. montieren der Tragetasche**

Kleben Sie zuerst den Klettverschluss am vorderen Ende des Korbes auf den unteren Stoff des Rahmens und befestigen Sie dann die Schnalle des unteren Stoffes des Korbes um das Rahmenrohr. Zum Zusammenklappen in umgekehrter Reihenfolge vorgehen.

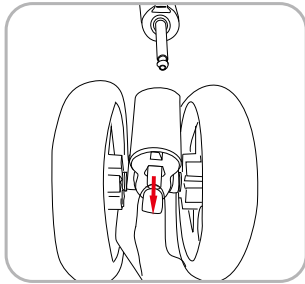
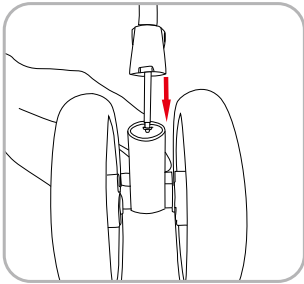

4. Verwendung der Vorderräder  
Setzen Sie den Vorderradsatz in den Vorderradsitz ein; er ist installiert, wenn Sie "Klick" hören.  
Drücken Sie die Schnalle am Vorderradsatz mit der Hand und ziehen Sie sie nach unten, dann wird der Vorderradsatz entfernt.

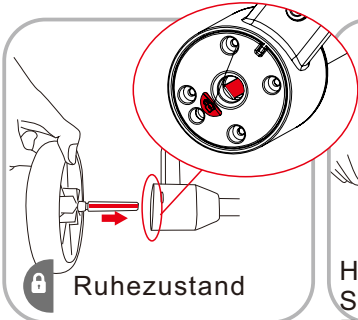

Ruhezustand

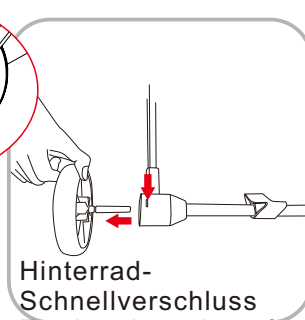

Hinterrad-Schnellverschluss Entriegelungsknopf

5. die Verwendung des Hinterrads  
Einbau: Richten Sie die flache Form der Radachse mit der Verriegelungsrichtung des Hinterrads aus  und schieben Sie es parallel ein, bis Sie ein Klicken hören.  
Wenn Sie demontieren müssen, drücken und halten Sie die Hinterrad-Schnellspanner-Taste und ziehen Sie es zur gleichen Zeit heraus.

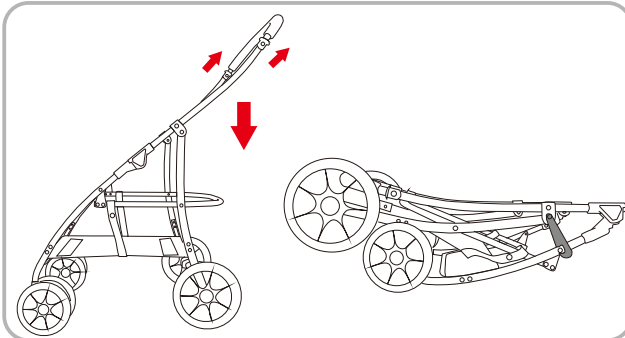

#### 6. faltbarer Rahmen

Im Bremszustand, nehmen Sie den Träger heraus, heben Sie zuerst die beiden Seiten der Faltschlüssel an, halten Sie den Griff, um nach unten zu drücken, der Rahmen kann gefaltet werden, hängen Sie schließlich den Haken.

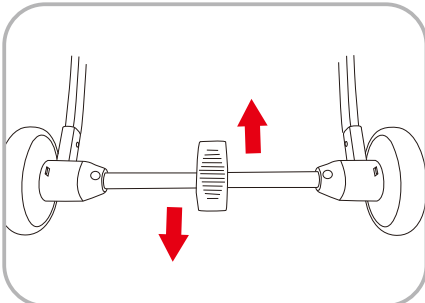

7. drücken Sie die Bremsen auf beiden Seiten herunter, die Bremse funktioniert.  
Umgekehrt kann sie auch gelöst werden.

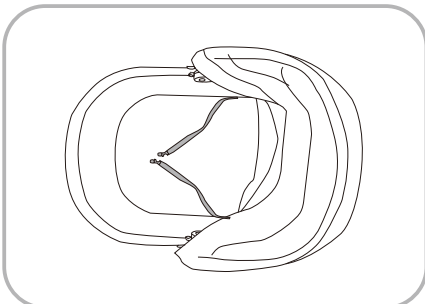

8. für Sicherheitsgurte für Haustiere

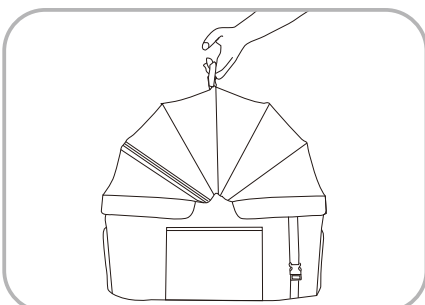

9. von Hand heben

**AVVERTENZA: Tenere lontano dal fuoco**

1. Si prega di leggere attentamente le presenti istruzioni prima dell'uso e di conservarle per future consultazioni. Se non si seguono queste istruzioni, la sicurezza degli animali domestici potrebbe essere compromessa.
2. Non lasciare andare la persona che assiste quando il prodotto è in uso.
3. Non utilizzare accessori non forniti dal produttore.
4. Qualsiasi carico attaccato alla maniglia influisce sulla stabilità del passeggino.
5. Assicurarsi che tutti i dispositivi di bloccaggio siano montati prima di utilizzare il passeggino.
6. Gli animali domestici devono essere trattiene durante l'uso.
7. Non utilizzare il passeggino in zone impervie, vicino a stufe o altre aree pericolose.
8. Evitare l'uso o lo stoccaggio in ambienti umidi, freddi o ad alta temperatura e tenerlo lontano dal fuoco o da fonti di calore forte.
9. Non utilizzarlo per animali pericolosi, aggressivi e distruttivi.

**Manutenzione e Cura**

Controllare e mantenere frequentemente il passeggino per animali domestici. Il rivestimento in tessuto non può essere immerso in liquido e lavato. Quando si pulisce il rivestimento in tessuto, utilizzare una spazzola e altri strumenti di pulizia per pulire lo sporco.

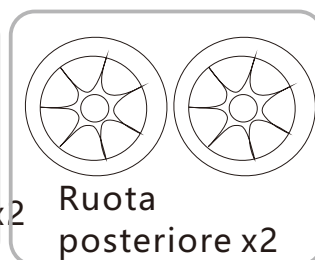
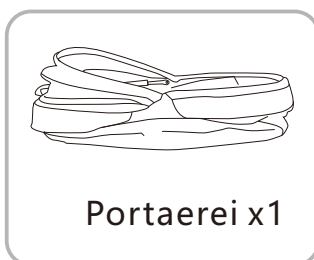
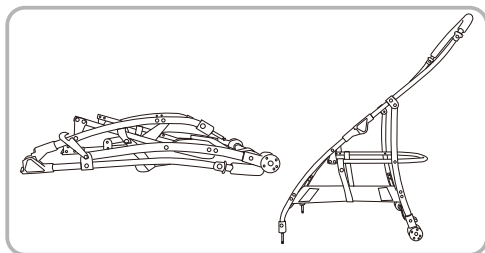
**Parti di ricambio****Istruzioni per l'uso****1. Aprire il telaio**

Estrarre il telaio, tenere il manubrio con entrambe le mani e sollevarlo fino a quando non si sente uno scatto che indica che il telaio è completamente aperto.

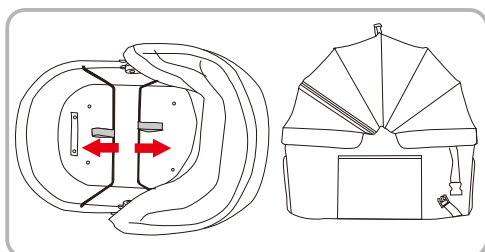
**2. Svolgimento del trasportino**

Estrarre il trasportino, premere la piastra inferiore con una mano e tirare la cinghia del supporto in ferro con l'altra mano in direzione della freccia a 45 gradi, finché il supporto in ferro su entrambi i lati non è completamente incastrato nella fessura. Per ripiegarlo, eseguire l'operazione inversa.

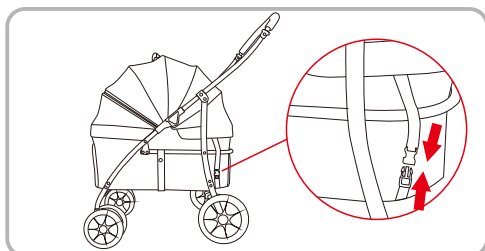
**3. Installazione del trasportino**

Per prima cosa, incollare il velcro all'estremità anteriore del cestino al tessuto inferiore del telaio, quindi fissare la fibbia del tessuto inferiore del cestino attorno al tubo del telaio. Per ripiegarlo, eseguire l'operazione inversa.

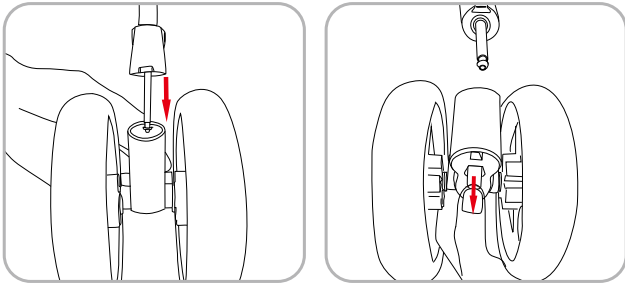

#### 4. Utilizzo delle ruote anteriori

Inserire il set di ruote anteriori nella sede delle ruote anteriori; l'installazione avviene quando si sente "Click".

Premere con la mano la fibbia sulla sede della ruota anteriore e tirarla verso il basso, quindi rimuovere il set di ruote anteriori.

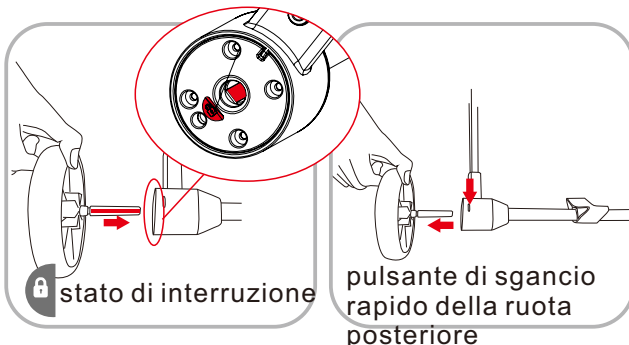

#### 5. Uso della ruota posteriore

Installare: in stato di rottura, allineare la forma piatta dell'asse della ruota con la direzione di bloccaggio della ruota posteriore e inserirla in parallelo fino a sentire un clic.

Quando è necessario smontare, tenere premuto il pulsante di sgancio rapido della ruota posteriore ed estrarla contemporaneamente.

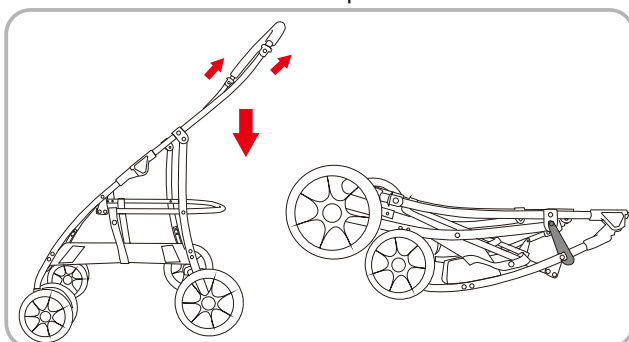

#### 6. Telaio pieghevole

In stato di frenata, estrarre il supporto, sollevare prima i due lati dei tasti di piegatura, tenere la maniglia per premere verso il basso, il telaio può essere piegato, infine appendere il gancio.

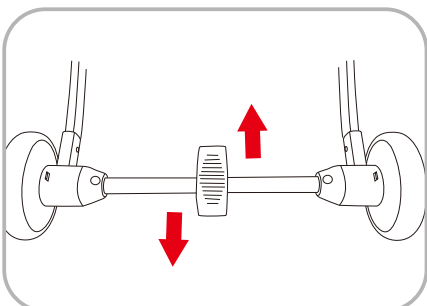

#### 7. Premere i freni su entrambi i lati, il freno funziona.

Al contrario, può essere rilasciato.

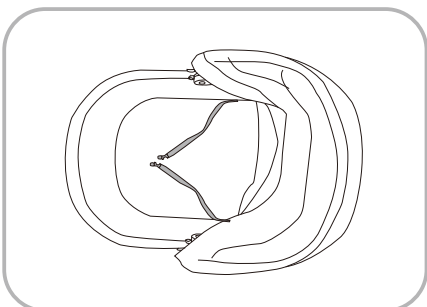

#### 8. Per le cinture di sicurezza per animali domestici

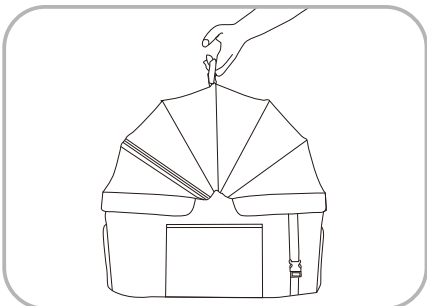

#### 9. Sollevare a mano

If you have any questions, please contact our customer care center, Our contact details are below:

**US**

 001-877-644-9366

 customerservice@aosom.com

Imported by Aosom LLC  
27150 SW Kinsman Rd Wilsonville, OR 97070 USA  
MADE IN CHINA

If you have any questions, please contact our customer care center, Our contact details are below:

**CA**

 416-792-6088

 customerservice@aosom.ca

Imported by Aosom Canada Inc.  
7270 Woodbine Avenue, Unit 307, Markham,  
Ontario Canada L3R 4B9  
MADE IN CHINA

Si vous avez la moindre question, veuillez contacter notre centre d'assistance à la clientèle, Nos coordonnées sont les suivantes:

 416-792-6088

 customerservice@aosom.ca

Importé par Aosom Canada Inc.  
7270 Woodbine Avenue, unité 307,  
Markham, Ontario Canada L3R 4B9  
FABRIQUÉ EN CHINE

If you have any questions, please contact our customer care center, Our contact details are below:

**UK**

 0044-800-240-4004

 enquiries@mhstar.co.uk

IMPORTER ADDRESS:  
MH STAR UK LTD  
Unit 27, Perivale Park,  
Horsenden lane South  
Perivale, UB6 7RH  
MADE IN CHINA

Si vous avez la moindre question, veuillez contacter notre centre d'assistance à la clientèle, Nos coordonnées sont les suivantes:

**FR**

 0033-1-84166106

 aosom@mhfrance.fr

Importé par/Fabricant/REP:  
MH FRANCE  
2 Rue Maurice Hartmann  
92130 Issy Les Moulineaux  
France  
FABRIQUÉ EN CHINE

Wenn Sie Fragen haben, wenden Sie sich bitte an unser Kundendienstzentrum, Unsere Kontaktdaten stehen unten:

**DE**

 0049-0(40)-88307530

 service@aosom.de

ADRESSE DES IMPORTEURE/Hersteller/REP:  
MH Handel GmbH  
Wendenstraße 309  
D-20537 Hamburg  
Germany  
IN CHINA HERGESTELLT

In caso di dubbio, si prega di contattare il nostro centro assistenza clienti, I nostri dettagli di contatto sono di seguito:

**IT**

 0039-0249471447

 clienti@aosom.it

IMPORTATO DA/Produttore/REP:  
AOSOM Italy srl  
Centro Direzionale Milanofiori  
Strada 1 Palazzo F1  
20057 Assago (MI)  
P.I.: 08567220960  
FATTO IN CINA

Si tiene alguna pregunta, comuníquese con nuestro Centro de Atención al Cliente, Nuestros datos de contacto son los siguientes:

**ES**

 0034-931294512

 atencioncliente@aosom.es

IMPORTADOR/Fabricante/REP:  
SPANISH AOSOM, S.L.  
C/ROC GROS, N°15.08550, ELS HOSTALETES DE  
BALENYÀ, SPAIN.  
B66295775  
HECHO EN CHINA

Se tiver alguma dúvida, por favor contacte o nosso Centro de Atendimento ao Cliente, Os nossos dados de contacto são os seguintes:

**PT**

 0034-931294512

 info@aosom.pt.

IMPORTADOR/Fabricante/REP:  
SPANISH AOSOM, S.L.  
C.ROC GROS N.15, 08550. ELS HOSTALETES DE  
BALENYÀ  
FEITO NA CHINA



**FR**

**DONNEZ  
OU  
RECYCLEZ**



ASSOCIATION

OU



LIVRAISON

OU



DÉCHÈTERIE

Adresses sur [quefairedemesdechets.fr](http://quefairedemesdechets.fr)