

## TIRE CHANGE STAND WITH BEAD BREAKER

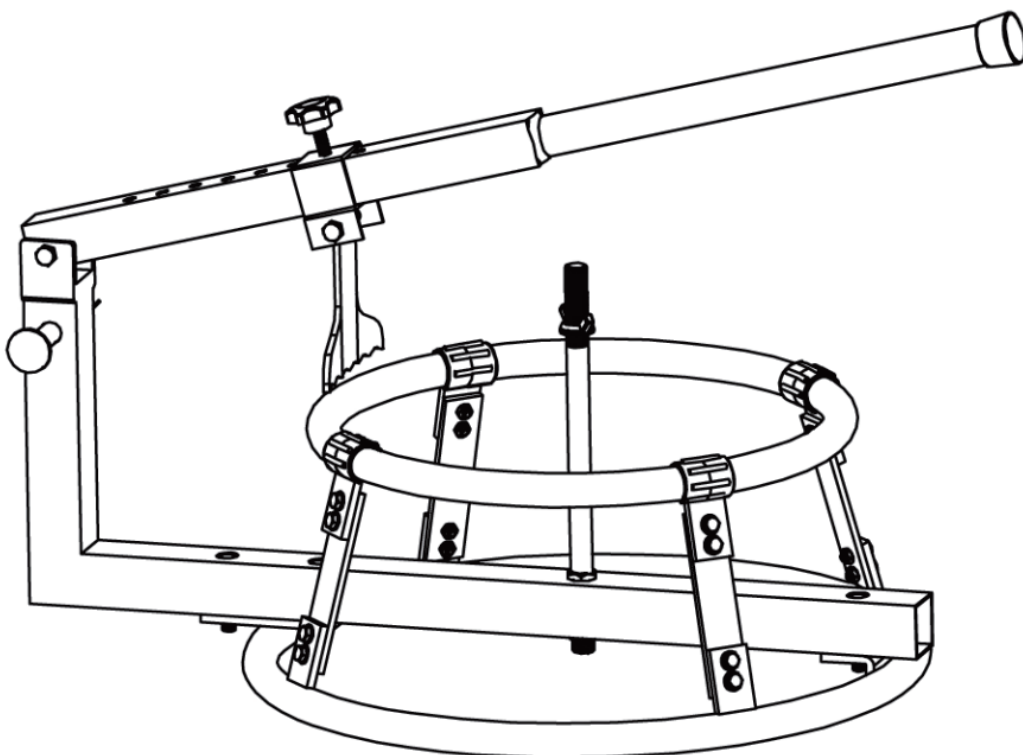

1. Using 4 M6 bolts and 4 nuts with washers on both sides for each ring support plate, connect the bottom base ring with the top ring with the 4 ring support plates.
2. Using the 3 M10 Allen head bolts attach the tire changer base bar to the bottom base ring.
3. Attach the axle stud to the tire changer base bar using the 2 nuts top and bottom of tire changer base bar.
4. Attach the bead breaker spade mount to the bead breaker arm. You will be able to adjust the spade for the size of wheel.
5. Mount the bead breaker arm to the tire changer base bar.
6. Snap on the 4 rim protectors 90° from each other on the top ring.

**IMPORTANT, RETAIN FOR FUTURE REFERENCE: READ CAREFULLY**

# ASSEMBLY INSTRUCTIONS

**UK**

If you have any questions, please contact our customer care center.

Our contact details are below:



0044-800-240-4004



enquiries@mhstar.co.uk

IMPORTER ADDRESS:

MH STAR UK LTD

Unit 27, Perivale Park,  
Horsenden lane South  
Perivale, UB6 7RH  
MADE IN CHINA

**ES**

Si tiene alguna pregunta, comuníquese con nuestro Centro de Atención al Cliente. Nuestros datos de contacto son los siguientes:



0034-931294512



atencioncliente@aosom.es

IMPORTADOR:

SPANISH AOSOM, S.L.

C/ ROC GROS, N° 15. 08550, ELS HOSTALETS DE  
BALENYÀ, SPAIN.

B66295775

WWW.AOSOM.ES

ATENCIONCLIENTE@AOSOM.ES

TEL: 931294512

HECHO EN CHINA

**FR**

Si vous avez la moindre question, veuillez contacter notre centre d'assistance à la clientèle.

Nos coordonnées sont les suivantes:



0033-1-84166106



aosom@mhfrance.fr

Importé par:

MH France

2, rue Maurice Hartmann  
92130 Issy-les-Moulineaux  
France  
Fabriqué en Chine

**PT**

Se tiver alguma dúvida, por favor contacte o nosso Centro de Atendimento ao Cliente. Os nossos dados de contacto são os seguintes:



0034-931294512



info@aosom.pt.

IMPORTADOR:

SPANISH AOSOM, S.L

C.ROC GROS N.15, 08550. ELS HOSTALETS DE BALENYÀ  
TEL: 931294512 (SEG-SEX DAS 7:30H ÀS 16:30H)

INFO@AOSOM.PT

WWW.AOSOM.PT

**DE**

Wenn Sie Fragen haben, wenden Sie sich bitte an unser Kundendienstzentrum.

Unsere Kontaktdaten stehen unten:



0049-0(40)-88307530



service@aosom.de

ADRESSE DES IMPORTEURE:

MH Handel GmbH  
Wendenstraße 309  
D-20537 Hamburg  
Germany  
IN CHINA HERGESTELLT

**IT**

In caso di dubbio, si prega di contattare il nostro centro assistenza clienti. I nostri dettagli di contatto sono di seguito:



0039-0249471447



clienti@aosom.it

IMPORTATO DA:

AOSOM Italy srl

Centro Direzionale Milanofiori

Strada 1 Palazzo F1

20057 Assago (MI)

P.I.: 08567220960

FATTO IN CINA

**US**

If you have any questions, please contact our customer care center.  
Our contact details are below:



001-877-644-9366



customerservice@aosom.com

Imported by Aosom LLC  
27150 SW Kinsman Rd Wilsonville, OR 97070 USA  
MADE IN CHINA

**CA**

If you have any questions, please contact our customer care center.  
Our contact details are below:

Si vous avez la moindre question, veuillez contacter notre centre d'assistance à la clientèle.  
Nos coordonnées sont les suivantes:



416-792-6088



customerservice@aosom.ca

Imported by Aosom Canada Inc.  
7270 Woodbine Avenue, Unit 307, Markham, Ontario Canada L3R 4B9  
MADE IN CHINA

Importé par Aosom Canada Inc.  
7270 Woodbine Avenue, unité 307, Markham, Ontario Canada L3R 4B9  
Fabriqué en Chine

ASSEMBLY DIAGRAM:

- 1 Bead Breaker Spade Mount
- 2 Bead Breaker Arm
- 3 Bead Breaker Spade
- 4 Rim Protectors
- 5 Top Ring
- 6 Ring Support Plates
- 7 Axle Stand
- 8 Leverage Pin
- 9 Tire Hanger Base Bar
- 10 Bottom Base Ring

INCLUDED:

QTY	PART
1	Bottom base ring
1	Tire changer base bar
1	Top ring
1	Bead breaker arm
1	Bead breaker spade mount
1	Bead breaker spade
1	Axle stud
4	Ring support plates
4	Rim protectors
2	Axle stud nuts M14
3	M10 Allen head bolts
2	M8 x 60
2	M8 lock nuts
16	M6 bolts
16	M6 nuts
16	M6 washers

