

EN_Tips: Please do not use in bad weather to avoid damage.

FR_Conseils : Ne pas utiliser par mauvais temps afin d'éviter tout dommage.

ES_Consejos: No utilizar con mal tiempo para evitar daños.

PT_Dicas: Não utilizar com mau tempo para evitar danos.

DE_Tipps: Bitte nicht bei schlechtem Wetter verwenden, um Schäden zu vermeiden.

IT_Suggerimenti: non utilizzare in caso di maltempo per evitare danni.

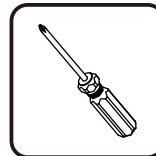
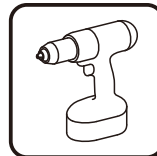
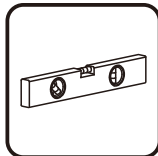
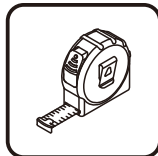
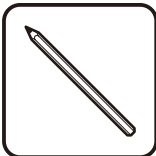
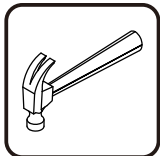

Tools Recommended

EN_IMPORTANT, RETAIN FOR FUTURE REFERENCE: READ CAREFULLY.

FR_IMPORTANT: A LIRE ATTENTIVEMENT ET À CONSERVER POUR CONSULTATION ULTÉRIEURE.

ES_IMPORTANTE, LEA Y GUARDE PARA FUTURAS REFERENCIAS.

PT_IMPORTANTE, RETER PARA REFERÊNCIA FUTURA: LEIA ATENTAMENTE.

DE_WICHTIG! SORGFÄLTIG LESEN UND FÜR SPÄTER NACHSCHLAGEN AUFBEWAHREN.

IT_IMPORTANTE! CONSERVARE IL PRESENTE MANUALE PER FUTURO RIFERIMENTO E LEGGERLO ATTENTAMENTE.

PARTS

A x 2



B x 1

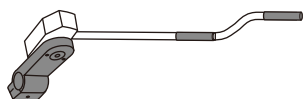

C x 2



D x 2

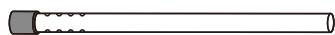

E x 2

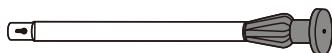

F x 1

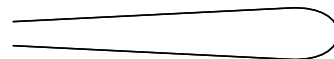

G x 1

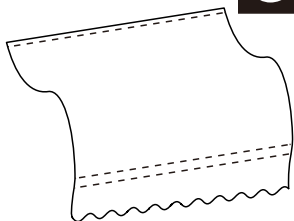

H1 x 2

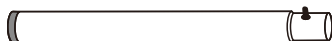

H2 x 1



J1 x 1

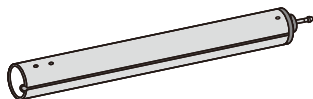

J2 x 1

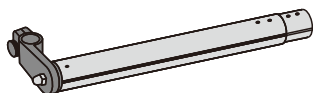

J3 x 1

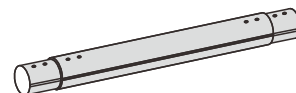

HARDWARE

S x 8
+1(spare)



P x 2

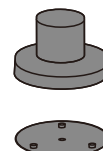

Q x 2

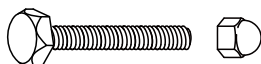

N x 2

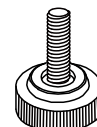

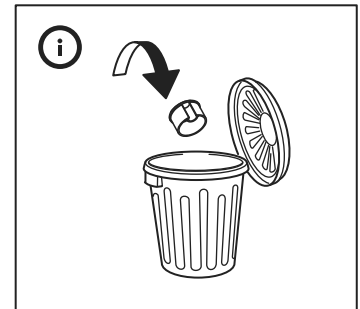
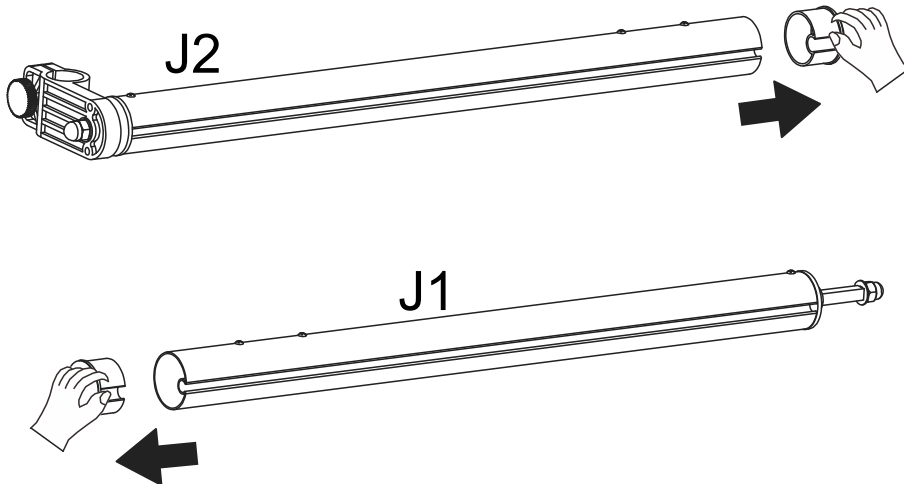
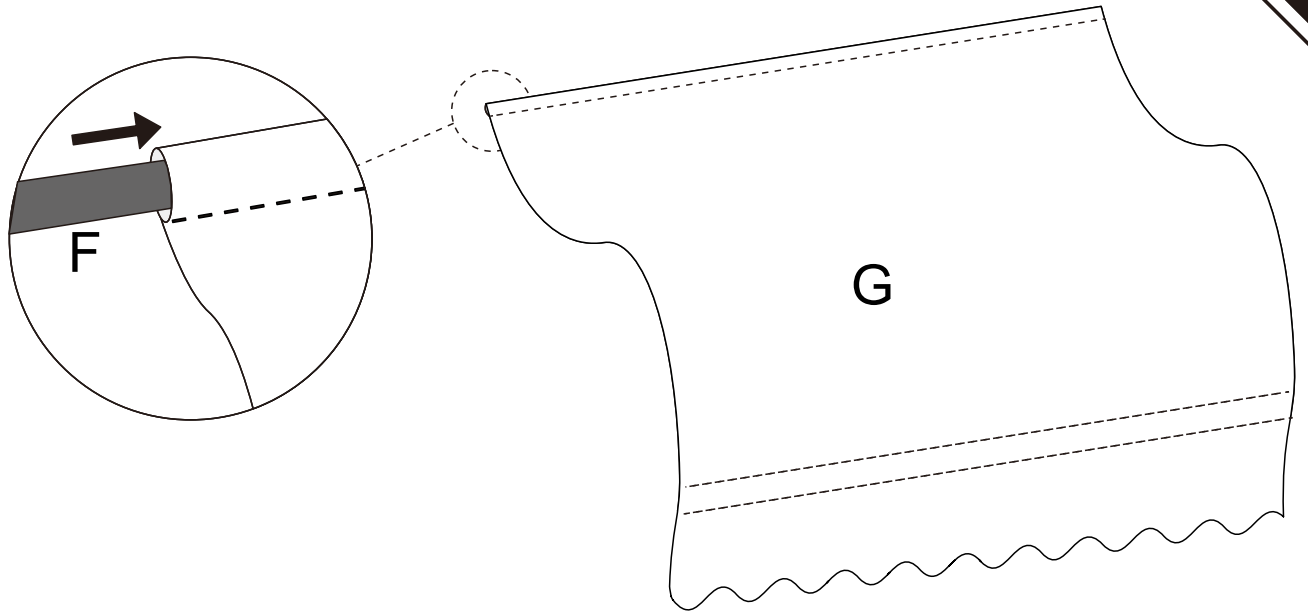

EN_NOTE: Please remove the circular protector caps on the end of each pole before assembling.

If the caps were broken, It will not affect the use of.

FR_REMARQUE : Veuillez retirer les capuchons de protection circulaires à l'extrémité de chaque tige avant de les assembler.

Si les capuchons sont cassés, cela n'affectera en rien l'utilisation du produit.

ES_NOTA: Por favor, retire las tapas protectoras circulares de los extremos de cada poste antes de empezar a montar.

Si las tapas se rompen, esto no afectará en ningún caso al uso normal del producto.

PT_NOTA: Por favor remover as protecções circulares na extremidade de cada pólo antes da montagem. Se as protecções estiverem quebradas, não afetará a utilização das mesmas.

DE_HINWEIS: Bitte entfernen Sie vor dem Zusammenbau die runden Schutzkappen an den Enden der Stangen.

Wenn die Kappen zerbrochen sind, hat dies keinen Einfluss auf die Verwendung des Baumes.

IT_NOTA: rimuovere i cappucci protettivi circolari all'estremità di ciascun palo prima di montarli.

Se i cappucci sono rotti, questo non influisce sull'uso.

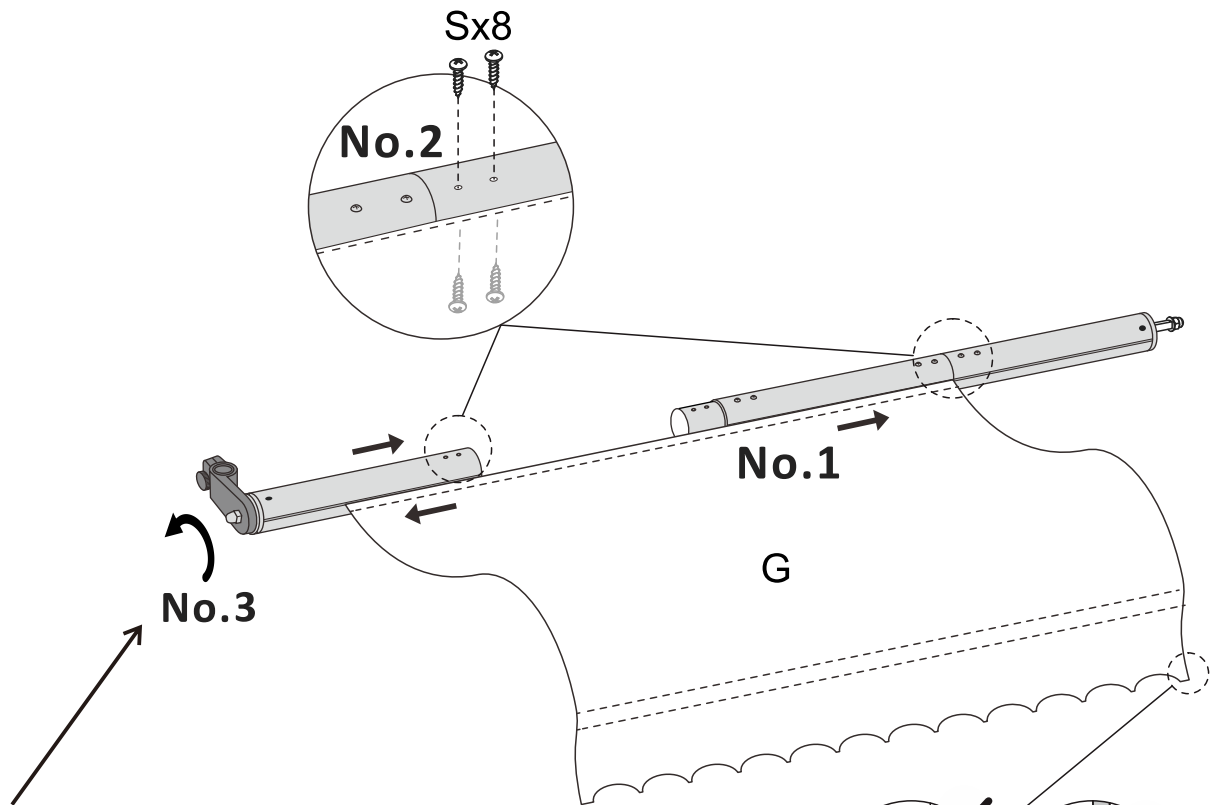

EN_Roll the fabric in this direction
FR_Rouler le tissu dans cette direction
ES_Enrolla la tela en esta dirección
PT_Enrolar o tecido nesta direção
DE_Rollen Sie den Stoff in diese Richtung
IT_Arrotolare il tessuto in questa direzione

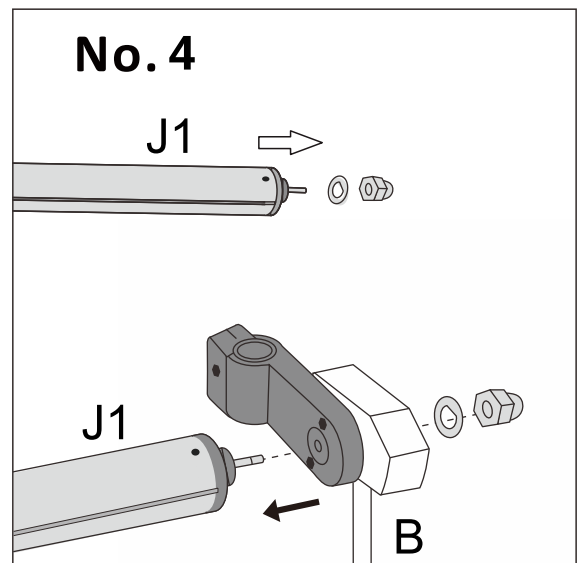
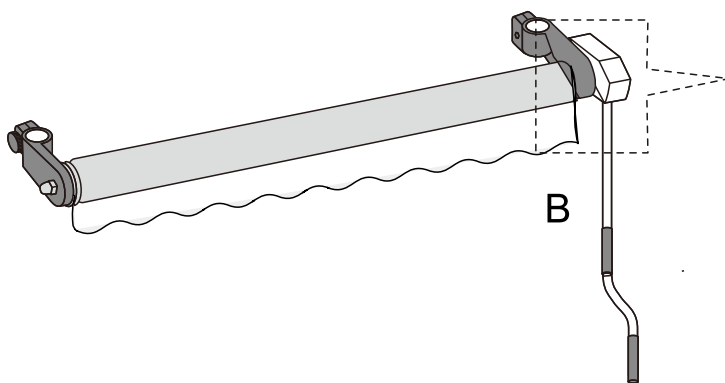

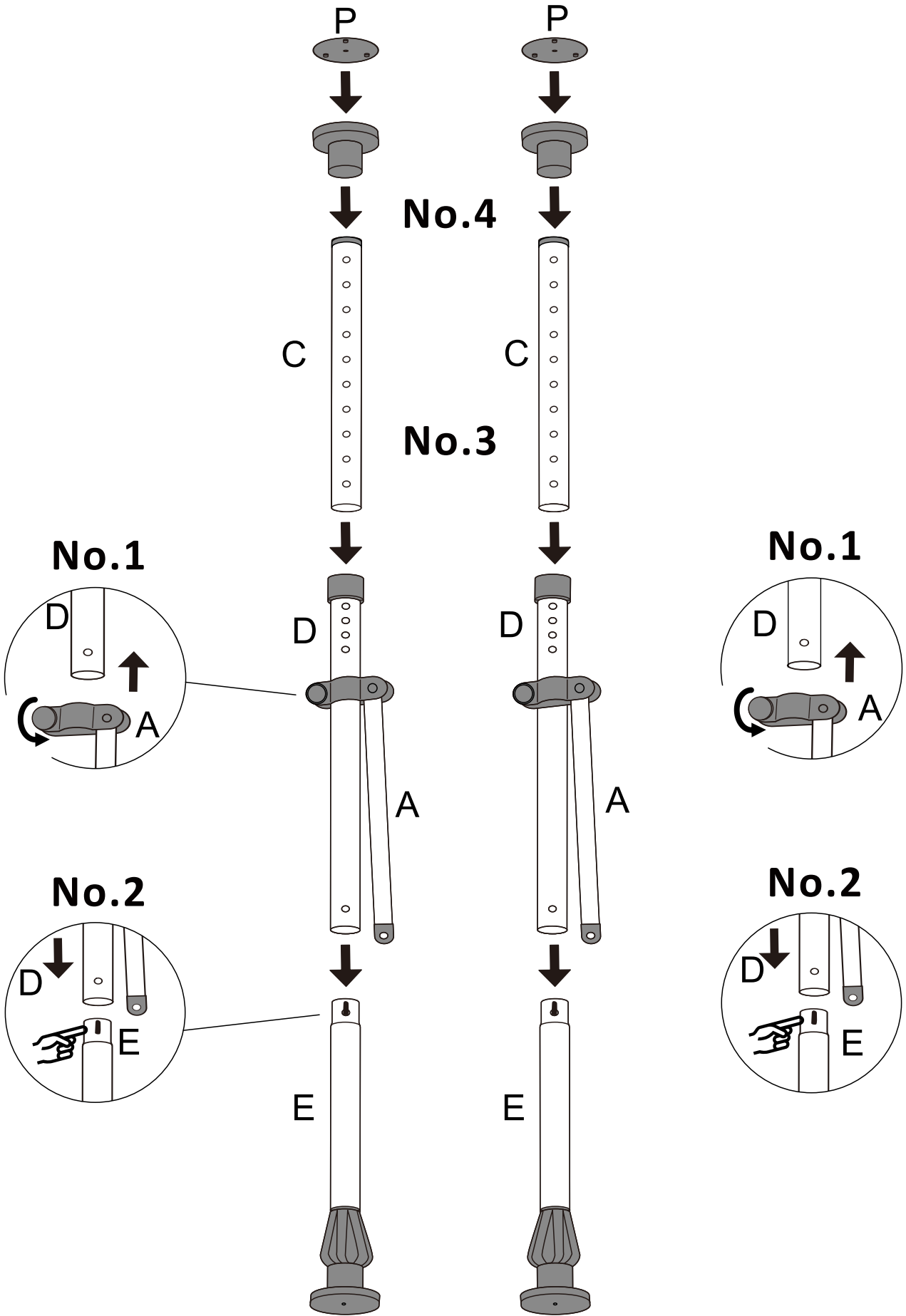

EN_ The installation height of the product should be adjusted according to the site used.

FR_ La hauteur d'installation du produit doit être ajustée en fonction du site utilisé.

ES_ La altura de instalación del producto debe ajustarse en función del lugar utilizado.

PT_ A altura de instalação do produto deve ser ajustada de acordo com o local utilizado.

DE_ Die Installationshöhe des Produkts sollte an den jeweiligen Standort angepasst werden.

IT_ L'altezza di installazione del prodotto deve essere regolata in base al sito utilizzato.

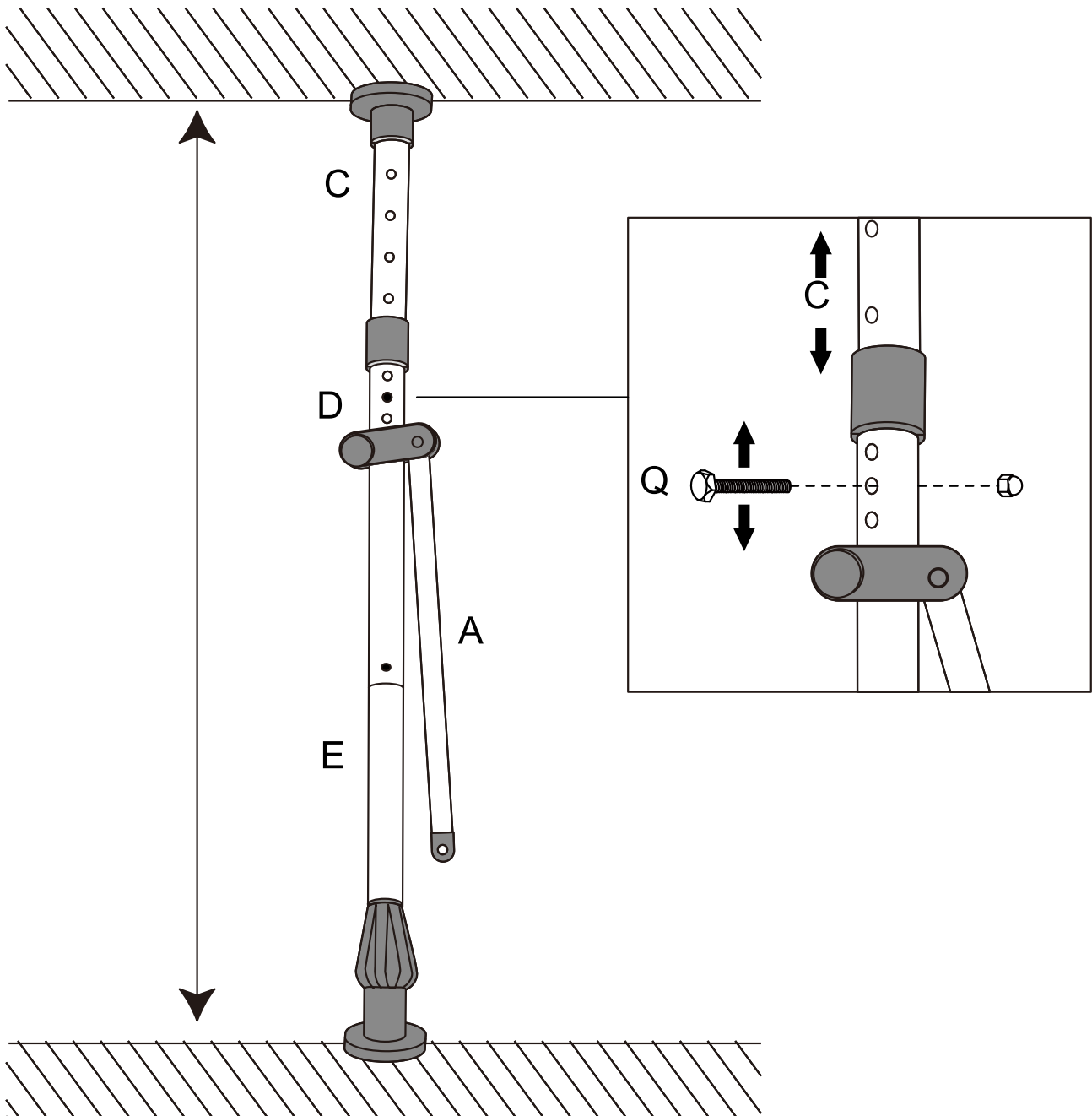

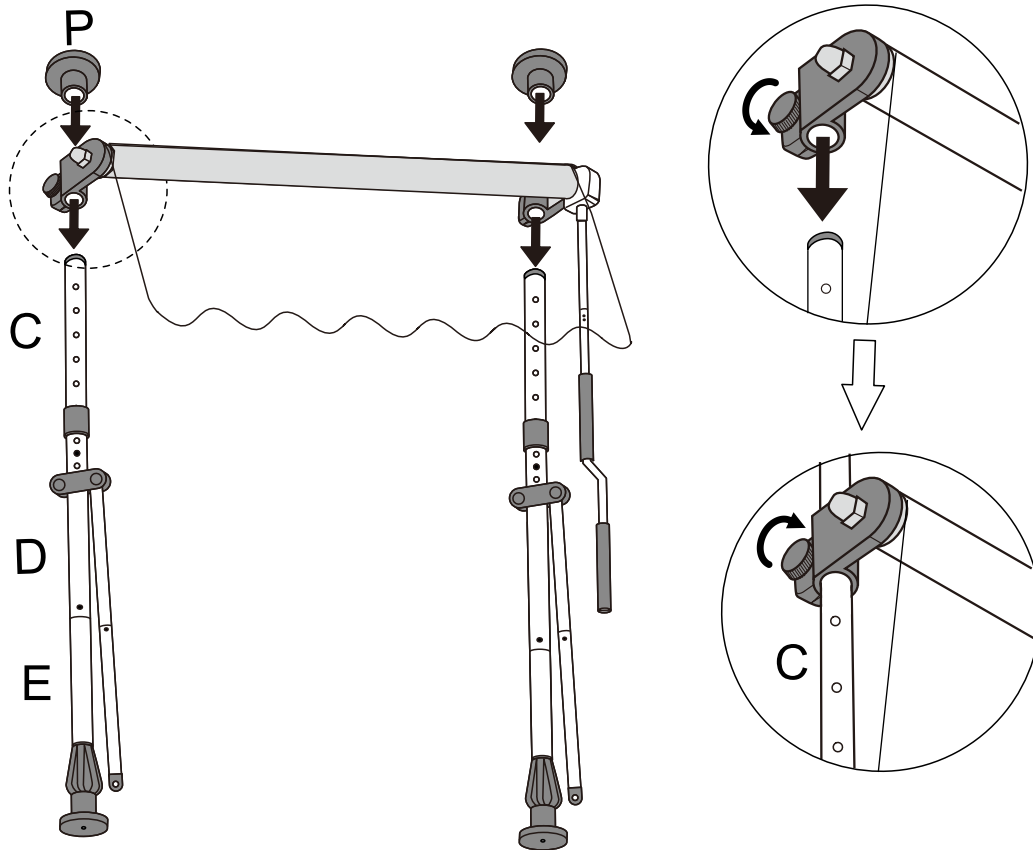

EN_ The length of the product is fixed and can't be adjusted.

FR_ La longueur du produit est fixe et ne peut être ajustée.

ES_ La longitud del producto es fija y no puede ajustarse.

PT_ O comprimento do produto é fixo e não pode ser ajustado.

DE_ Die Länge des Produkts ist fest und kann nicht verstellt werden.

IT_ La lunghezza del prodotto è fissa e non può essere regolata.

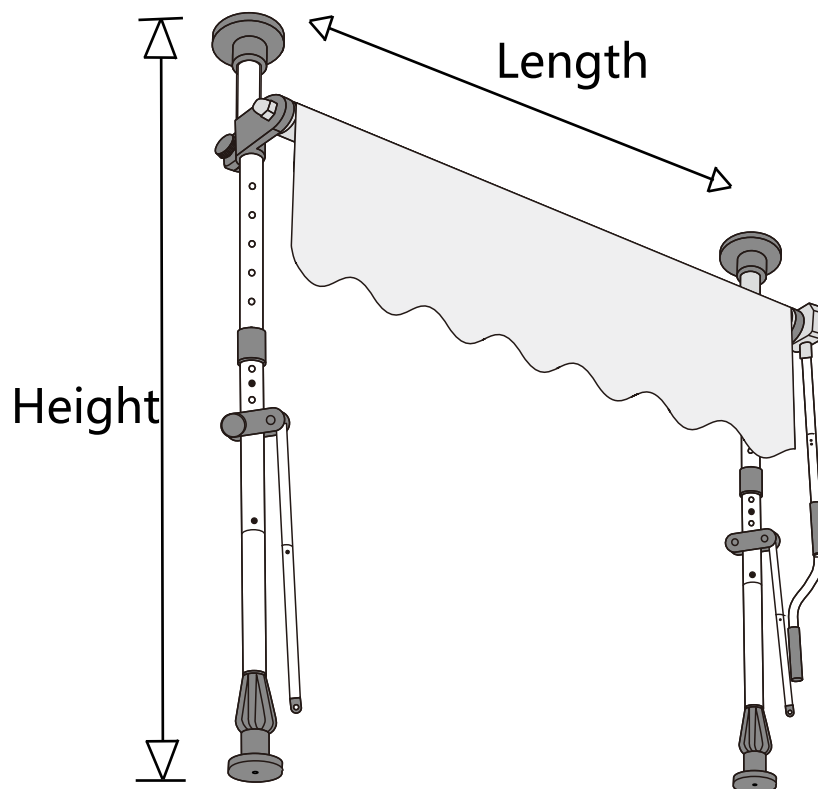

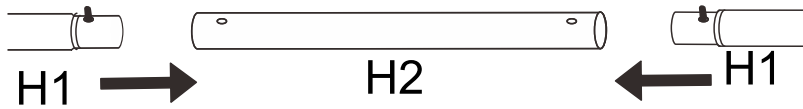
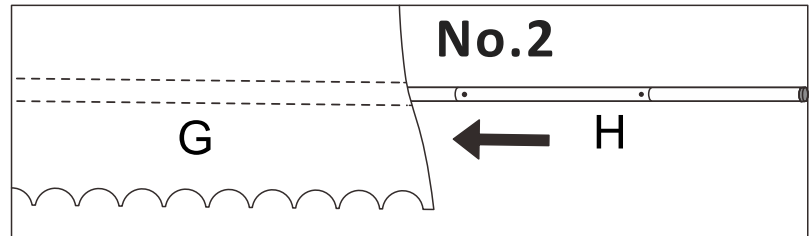
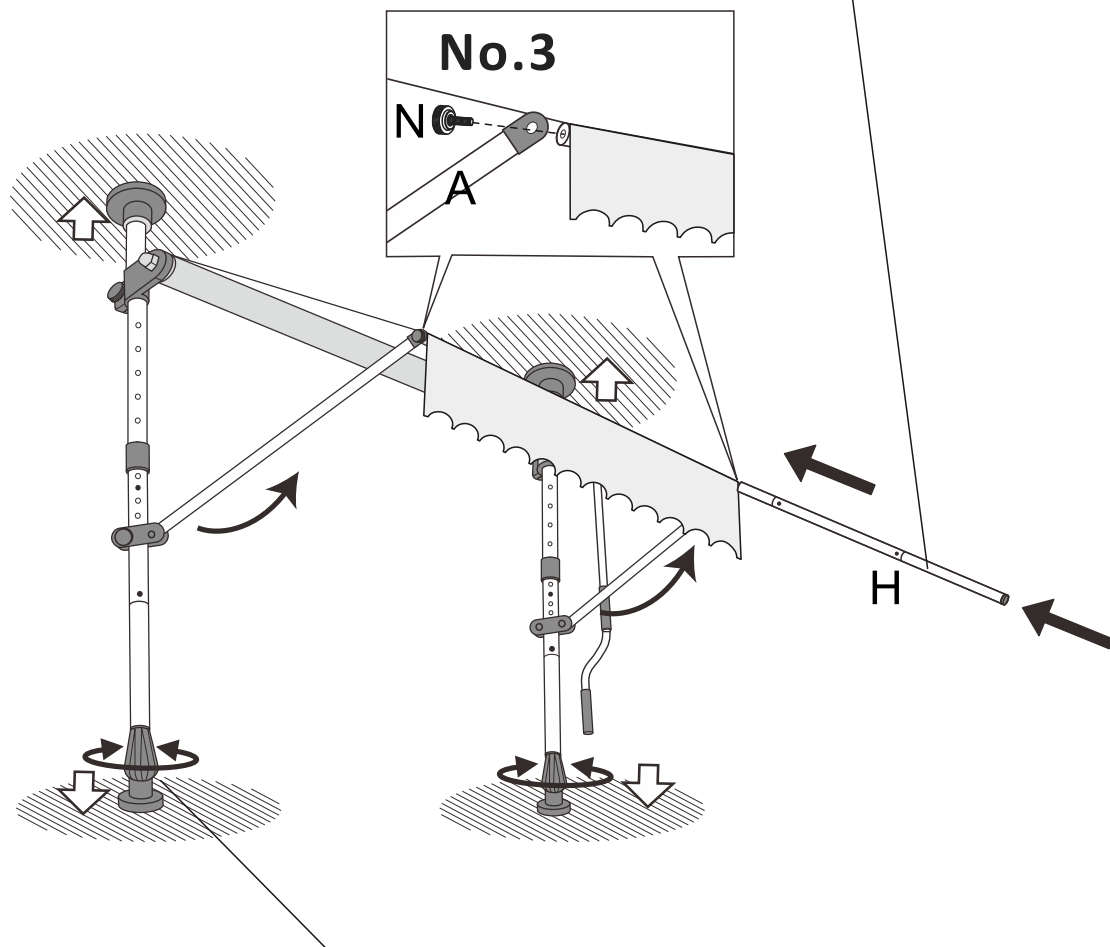
No.1**No.2****No.3**

EN Turn the bottom knob to slightly adjust the pole height, and the adjustable height range is 0-3cm.

FR Tournez le bouton inférieur pour ajuster légèrement la hauteur de la perche, et la plage de réglage de la hauteur est de 0 à 3 cm.

ES Gire la perilla inferior para ajustar ligeramente la altura del poste, y el rango de altura ajustable es de 0-3 cm.

PT Rode o botão inferior para ajustar ligeiramente a altura do poste, e o intervalo de altura ajustável é de 0-3 cm.

DE Drehen Sie den unteren Knopf, um die Höhe der Stange leicht zu verstellen. Der Höhenverstellbereich beträgt 0-3 cm.

IT Ruotando la manopola inferiore è possibile regolare leggermente l'altezza dell'asta, con un intervallo di regolazione di 0-3 cm.

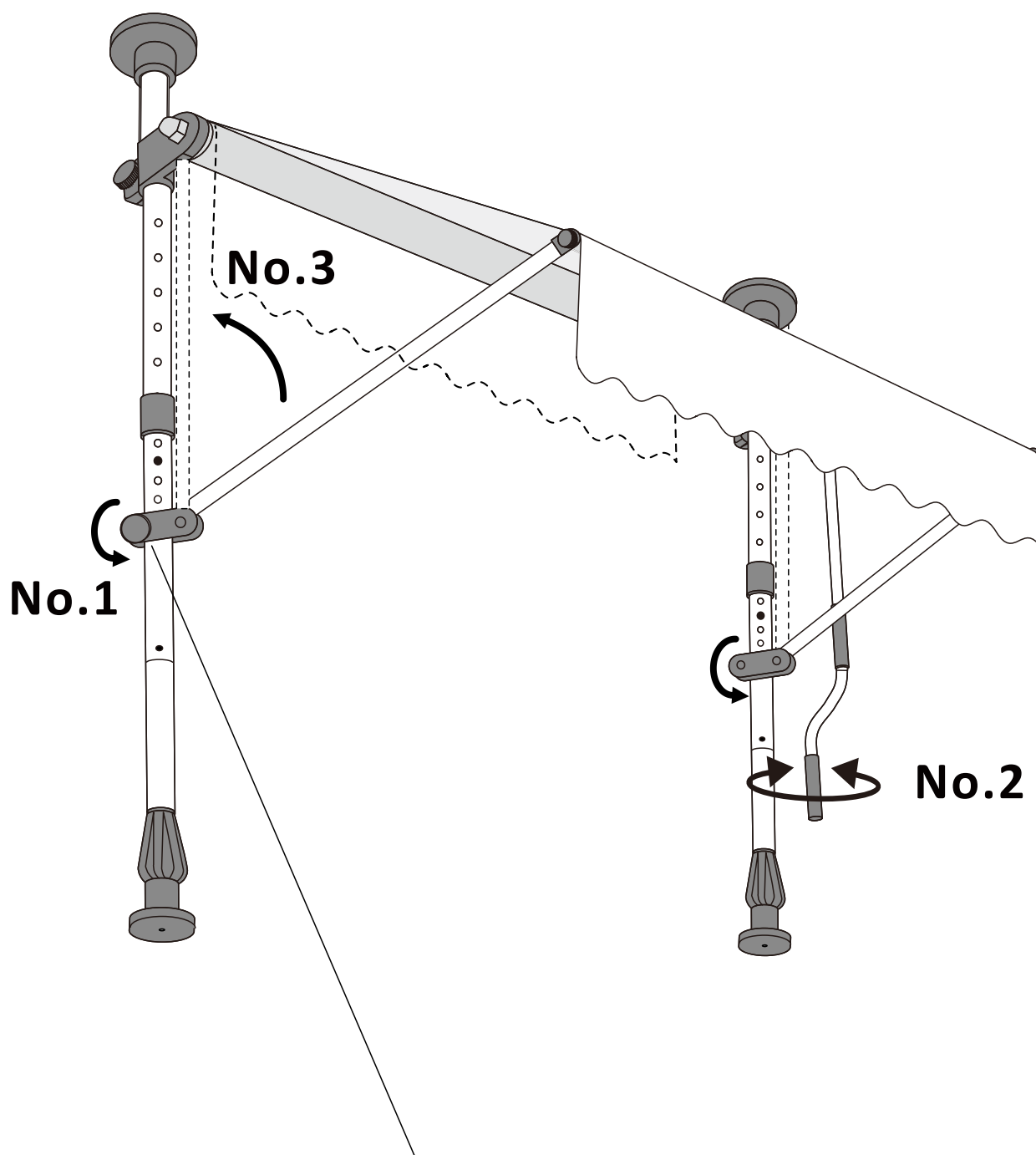

EN Loosen the knob on bar (1), then turn the hand crank (2) to close the awning. Until bar(1) is vertical to the ground, tighten the knob.



FR Desserrez le bouton de la barre (1), puis tournez la manivelle (2) pour fermer le store. Jusqu'à ce que la barre (1) soit à l'horizontale par rapport au sol, resserrez le bouton.

ES Afloje el pomo de la barra (1) y gire la manivela (2) para cerrar el toldo. Hasta que la barra (1) esté vertical al suelo, apriete el pomo.

PT Desapertar o botão da barra (1) e, em seguida, rodar a manivela (2) para fechar o toldo. Até que a barra (1) esteja na vertical em relação ao solo, aperte o botão.



DE Lösen Sie den Drehknopf an der Stange (1) und drehen Sie dann die Handkurbel (2), um die Markise zu schließen. Ziehen Sie den Drehknopf fest, bis die Stange (1) senkrecht zum Boden steht.



IT Allentare il pomello della barra (1), quindi girare la manovella (2) per chiudere la tenda. Finché la barra (1) non è verticale rispetto al suolo, stringere il pomello.

If you have any questions, please contact our customer care center. **US**
Our contact details are below:
 001-877-644-9366
 customerservice@aosom.com
Imported by Aosom LLC
27150 SW Kinsman Rd Wilsonville, OR 97070 USA
MADE IN CHINA

Si tiene alguna pregunta, comuníquese con nuestro Centro de Atención al Cliente. **ES**
Nuestros datos de contacto son los siguientes:
 0034-931294512
 atencioncliente@aosom.es
IMPORTADOR:
SPANISH AOSOM, S.L.
C/ ROC GROS, Nº 15. 08550, ELS HOSTALETES DE BALENYÀ, SPAIN.
B66295775
WWW.AOSOM.ES
HECHO EN CHINA



If you have any questions, please contact our customer care center. **CA**
Our contact details are below:
 416-792-6088
 customerservice@aosom.ca
Imported by Aosom Canada Inc.
7270 Woodbine Avenue, Unit 307, Markham, Ontario Canada L3R 4B9
MADE IN CHINA

Se tiver alguma dúvida, por favor contacte o nosso Centro de Atendimento ao Cliente. **PT**
Os nossos dados de contacto são os seguintes:
 0034-931294512 (SEG-SEX DAS 7:30H ÀS 16:30H)
 info@aosom.pt.
IMPORTADOR:
SPANISH AOSOM, S.L
C.ROC GROS N.15, 08550. ELS HOSTALETES DE BALENYÀ
WWW.AOSOM.PT

Si vous avez la moindre question, veuillez contacter notre centre d'assistance à la clientèle. **FR**
Nos coordonnées sont les suivantes:
 416-792-6088
 customerservice@aosom.ca
Importé par Aosom Canada Inc.
7270 Woodbine Avenue, unité 307, Markham, Ontario Canada L3R 4B9
Fabriqué en Chine

Wenn Sie Fragen haben, wenden Sie sich bitte an unser Kundendienstzentrum. **DE**
Unsere Kontaktdaten stehen unten:
 0049-0(40)-88307530  service@aosom.de
ADRESSE DES IMPORTEUR:
MH Handel GmbH
Wendenstraße 309
D-20537 Hamburg
Germany
IN CHINA HERGESTELLT

If you have any questions, please contact our customer care center. **UK**
Our contact details are below:
 0044-800-240-4004
 enquiries@mhstar.co.uk
IMPORTER ADDRESS:
MH STAR UK LTD
Unit 27, Perivale Park,
Horsenden lane South
Perivale, UB6 7RH
MADE IN CHINA

In caso di dubbio, si prega di contattare il nostro centro assistenza clienti. **IT**
I nostri dettagli di contatto sono di seguito:
 0039-0249471447  clienti@aosom.it
IMPORTATO DA:
AOSOM Italy srl
Centro Direzionale Milanofiori
Strada 1 Palazzo F1
20057 Assago (MI)
P.I.: 08567220960
FATTO IN CINA

Si vous avez la moindre question, veuillez contacter notre centre d'assistance à la clientèle. **FR**
Nos coordonnées sont les suivantes:  0033-1-84166106  aosom@mhfrance.fr
Importé par: MH France 2, rue Maurice Hartmann 92130 Issy-les-Moulineaux
Fabriqué en Chine
France



Adresses sur quefairedemesdechets.fr