

AIYAPLAY

IN240200103V01_UK_FR_DE_ES_IT

370-324V00



***Suitable for children of 12-36 Months.**

***Max weight: 25 kg.**

2022 Caterpillar. CAT, CATERPILLAR, and their design and marks are registered trademarks of Caterpillar Inc.

Ningbo Prince Toys Co., Ltd, a licensee of Caterpillar Inc.

IMPORTANT, RETAIN FOR FUTURE REFERENCE: READ CAREFULLY

ASSEMBLY INSTRUCTION

WARNING:

1. CHOKING HAZARD—Small parts.

Only allowed for adults to install, keep children away.

2. To be used under the direct supervision of an adult.

3. Just only allow one child to use.

4. Please use on a flat and clean surface. Never use near steps, sloped driveways, hills roadways, alleys, swimming pool areas, road, on grass or wet surfaces or other bodies of water.

5. Before driving toy car each time, adult should inspect screws of every parts, please tighten the screw cap if any looseness. secure all fasteners before every ride.

6. Always wear shoes and suitable protective equipment. always wear a local standard approved helmet while riding, with the chinstrap securely fastened.

7. Do not ride the product at dusk, at night or at times of limited visibility.

8. Always comply with local laws and regulations.

MAINTENANCE & CARE

A. Keep all instructions and parts relating to this product for future reference.

B. Regularly check for damage and that all screws are securely tightened.

C. Check that the seat is securely fastened.

D. Lubricate the chain as often as required.

E. Regularly check tyre pressures.

BATTERY HANDING :

1. Battery must be handled by adults only.

2. Always remove exhausted batteries.

3. Use AA size batteries only.

4. Alkaline batteries are recommended.

5. Always remove batteries when the unit is not going to be used for an extended period of time.

6. When replacing new batteries, always replace all batteries.

7. Do not mix old and new batteries.

8. Do not mix Alkaline, Standard(Carbon-Zinc),or Rechargeable(Nickel-Cadmium)batteries.

9. Do not dispose of batteries in fire, batteries may explode or leak.

10. Non-rechargeable batteries are not to be recharged.





















11. Rechargeable batteries are to be removed from the toy before being charged.

12. Rechargeable batteries are only to be charged under adult supervision.

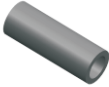
13. Batteries are to be inserted with the correct polarity

14. The supply terminals are not to be short-circuited.

COMPONENTS LIST

<p>1.Body 1pc</p> 	<p>2.Steering wheel 1pc</p> 	<p>3.Trailer 1pc</p> 
<p>4.Seat 1pc</p> 	<p>5.Exhaust-pipe 1pc</p> 	<p>6.Front wheel 2pcs</p> 
<p>7.Rear wheel cap 2pcs</p> 	<p>8.Rear wheel 2pcs</p> 	<p>9.Trailer wheel 2pcs</p> 
<p>10.Front wheel cap 4pcs</p> 	<p>11.Anti-tumble shelf 1pc</p> 	<p>12.Trailer connector 1pc</p> 
<p>13.J-sharped stick 1pc</p> 	<p>14.Wheel axle 2pcs</p> 	<p>15.Ring 6pcs</p> 
<p>16.Washer 7pcs (1replacement piece)</p> 	<p>17.Cotter pin 5pcs (1replacement piece)</p> 	<p>18.Black screw 2pcs (1replacement piece)</p> 
<p>19.Silver screw 4pcs (1replacement piece)</p> 	<p>20.Toy 2pcs</p> 	

Tractor assemble

Step 1

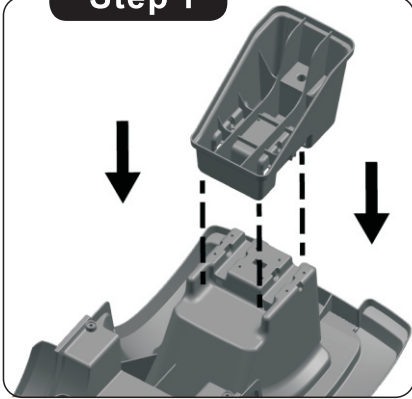

1. Place the anti-tumble shelf into the rear of the tractor body.

Step 2

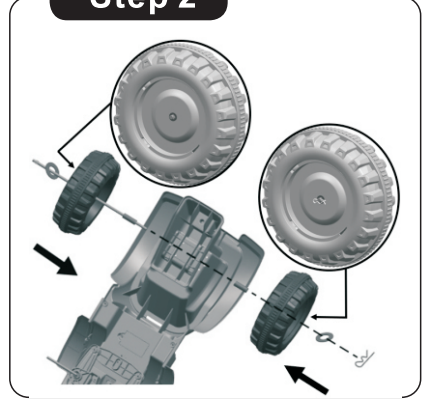

2. Insert the wheel axle through washer, rear wheel, plastic ring into the body, tighten using a cotter pin

Step 3

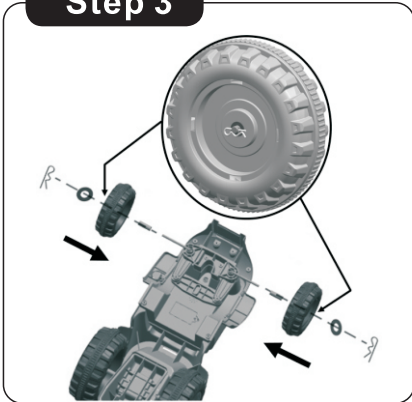

3. Assemble the two front wheels, insert the plastic ring, wheel and washer, tighten using a cotter pin.

Step 4

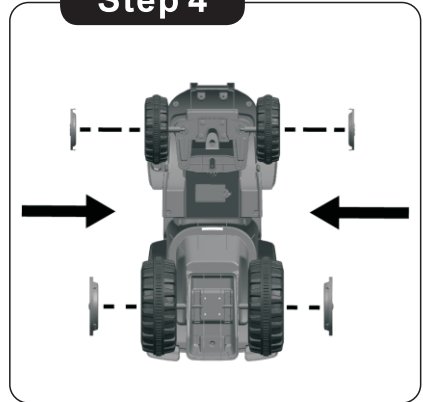

4. Place the two front wheel caps into the front wheels, and two rear wheel caps into the rear wheels.

Step 5

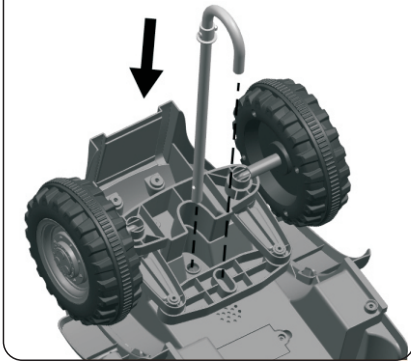

5. Install the J-shaped stick at the assigned location as picture.

Step 6

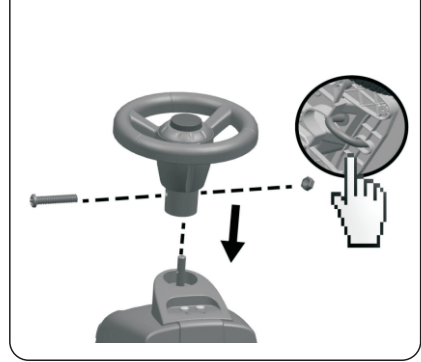

6. Loosen the bolt and nut in the steering wheel first, then place the steering wheel over the J-shaped stick, insert the bolt and tighten the nut with a screwdriver (not included)

Step 7



7. Assemble the seat, tighten with a black screw by a screwdriver (not included).

Step 8



8. Insert the exhaust pipe, be certain the exhaust pipe is completely seated.

Trailer assemble

Step 1

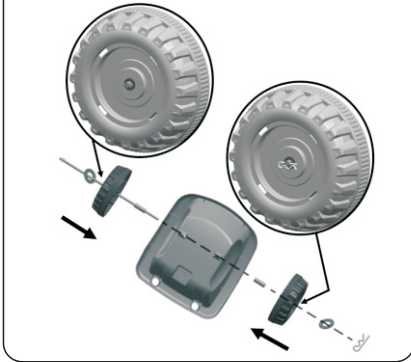

1.Insert the wheel axle through washer,trailer wheel,plastic ring into the trailer,tighten using a cotter pin.

Step 2

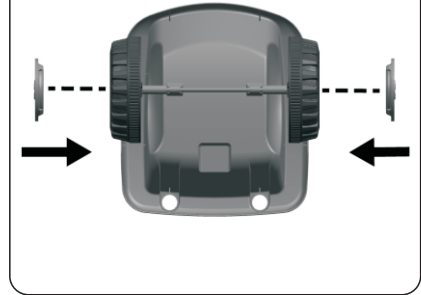

2.Place the two front wheel caps into the two trailer wheels.

Step 3

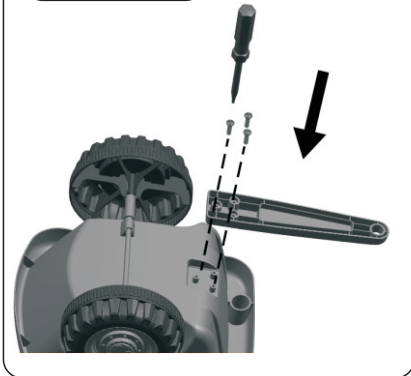

3.Assemble the trailer connector with three silver screws by a screwdriver(not included)

Step 4

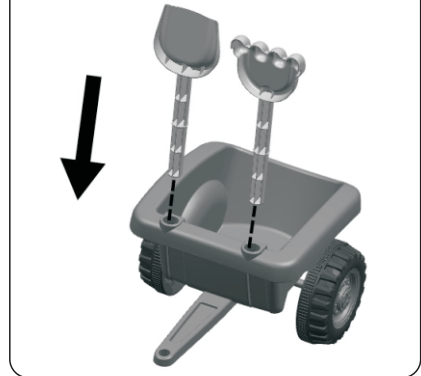

4.Insert the two toys into the holes of the trailer.

Step 5

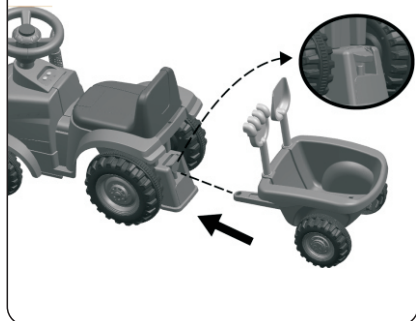

5. Open the lock and connect the trailer with tractor.

Battery change

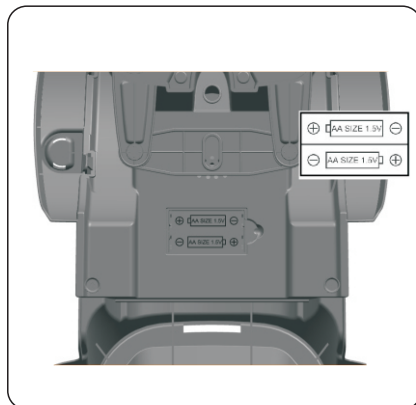
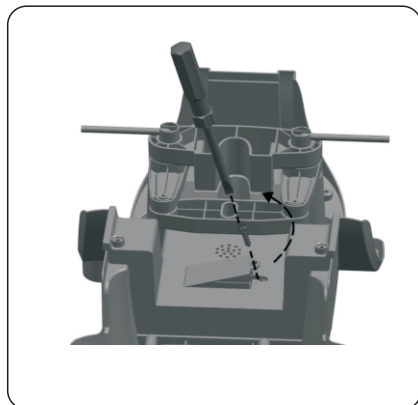

Turn over the tractor body, and find the battery house. Loosen the screw with a screwdriver (not included). Put 2 AA batteries in the battery house, then tight the screw with a screwdriver (not included).

Function

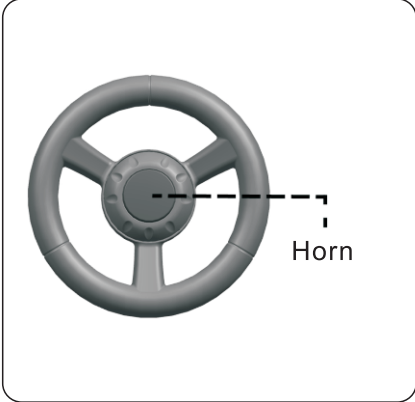

AIYAPLAY

IN240200103V01_UK_FR_DE_ES_IT

370-324V00



FR



***Convient aux enfants de 12 à 36 Mois.**

***Poids maximum : 25 kg.**

2022 Caterpillar. CAT, CATERPILLAR et leurs designs et marques sont des marques déposées de Caterpillar Inc. Ningbo Prince Toys Co., Ltd., un titulaire de licence de Caterpillar Inc.

IMPORTANT : LIRE ATTENTIVEMENT ET CONSERVEZ CE MANUEL POUR VOUS Y REFERER ULTERIEUREMENT.

Assemblage & manuel d'instructions

AVERTISSEMENT :

1. DANGER D'ÉTOUFFEMENT - Petites pièces.
Installation par des adultes uniquement, tenir les enfants à l'écart.
2. À utiliser sous la surveillance directe d'un adulte.
3. Ne doit être utilisé que par un seul enfant à la fois.
4. À utiliser sur une surface plane et propre. Ne jamais utiliser à proximité d'un escalier, d'une entrée en pente, d'une route en pente, d'une allée, d'une piscine, d'une route, sur l'herbe ou sur des surfaces mouillées ou d'autres plans d'eau.
5. Avant de conduire à chaque fois le jouet, l'adulte doit inspecter les vis de chaque pièce, veuillez serrer le bouchon à vis s'il est desserré. Fixez toutes les attaches avant chaque trajet.
6. Portez toujours des chaussures et un équipement de protection approprié. Portez toujours un casque homologué selon les normes locales pendant que vous roulez, avec la jugulaire solidement attachée.
7. Ne pas rouler au crépuscule, la nuit ou à des heures de visibilité réduite.
8. Respectez toujours les lois et règlements locaux.









ENTRETIEN ET MAINTENANCE

- A. Conservez toutes les instructions et les pièces relatives à ce produit pour pouvoir vous y référer ultérieurement.
- B. Vérifiez régulièrement que le produit n'est pas endommagé et que toutes les vis sont bien serrées.
- C. Vérifier que le siège est bien fixé.
- D. Lubrifiez la chaîne aussi souvent que nécessaire.
- E. Vérifiez régulièrement la pression des pneus.

Manipulation des piles :

1. Les piles ne doivent être manipulées que par des adultes.
2. Toujours retirer les piles épuisées.
3. Utiliser uniquement des piles de taille AA.
4. Les piles alcalines sont conseillées.
5. Toujours retirer les piles lorsque l'appareil n'est pas utilisé pendant une période prolongée.
6. Lorsque vous remplacez des piles neuves, remplacez toujours toutes les piles.
7. Ne mélangez pas les piles neuves et usagées.
8. Ne pas mélanger les piles alcalines, standard (carbone-zinc) ou rechargeables (nickel-cadmium).
9. Ne jetez pas les piles dans le feu, elles peuvent exploser ou présenter des fuites.
10. Les piles non rechargeables ne doivent pas être rechargées.
11. Les piles rechargeables doivent être retirées du jouet avant d'être rechargées.
12. Les piles rechargeables ne doivent être rechargées que sous la surveillance d'un adulte.
13. Les piles doivent être insérées en respectant la polarité.
14. Les bornes d'alimentation ne doivent pas être court-circuitées.

LISTE DES COMPOSANTS

<p>1.Carrosserie 1pc</p> 	<p>2.Volant de direction 1pc</p> 	<p>3.Remorque 1pc</p> 
<p>4.Siège 1pc</p> 	<p>5.Tuyau d'échappement 1pc</p> 	<p>6.Roue avant 2pcs</p> 
<p>7.Enjoliveur de roue arrière 2pcs</p> 	<p>8.Roue arrière 2pcs</p> 	<p>9.Roue de remorque 2pcs</p> 
<p>10.Enjoliveur de roue avant 4pcs</p> 	<p>11.Support anti- basculement 1pc</p> 	<p>12.Connecteur de remorque 1pc</p> 
<p>13.Tige en J 1pc</p> 	<p>14.Axe de roue 2pcs</p> 	<p>15.Anneau 6pcs</p> 
<p>16.Rondelle 7pcs (1 pièce de rechange)</p> 	<p>17.Goupille fendue 5pcs (1 pièce de remplacement)</p> 	<p>18.Vis noire 2pcs (1 pièce de remplacement)</p> 
<p>19.Vis argentée 4pcs (1 pièce de rechange)</p> 	<p>20.Jouet 2pcs</p> 	

Assemblage du tracteur

Étape 1

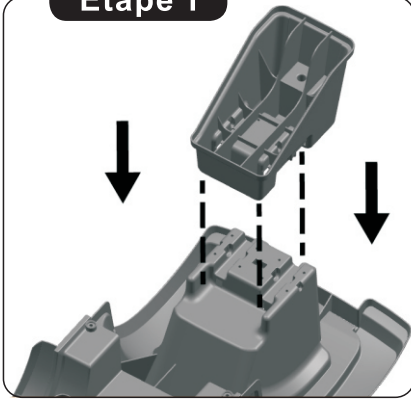

1. Placer le support anti-basculement à l'arrière de la carrosserie du tracteur.

Étape 2

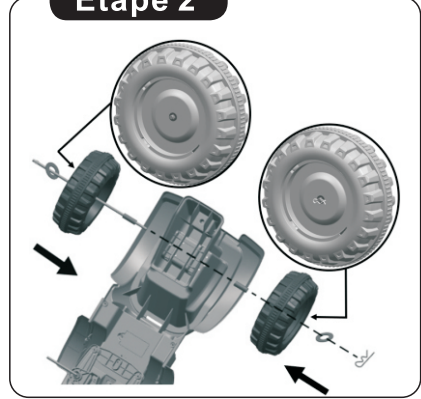

2. Insérez l'axe de la roue à travers la rondelle, la roue arrière et la bague en plastique dans la carrosserie, serrez à l'aide d'une goupille fendue.

Étape 3

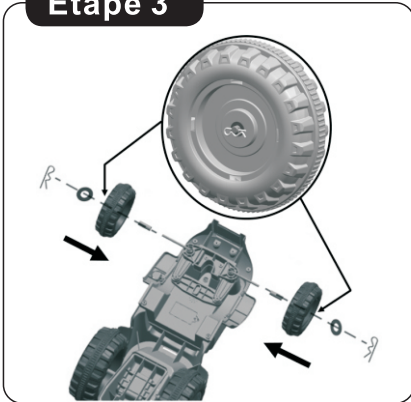

3. Assembler les deux roues avant, insérer l'anneau en plastique, la roue et la rondelle, serrer à l'aide d'une goupille fendue.

Étape 4

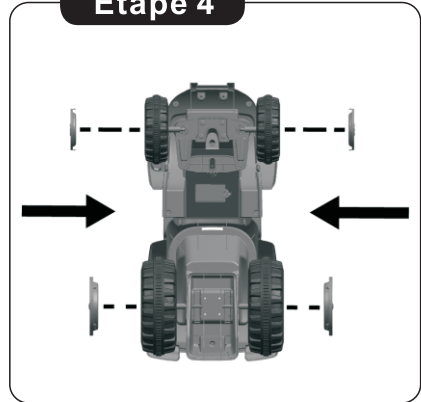

4. Placez les deux enjoliveurs de roues avant dans les roues avant et les deux enjoliveurs de roues arrière dans les roues arrière.

Étape 5

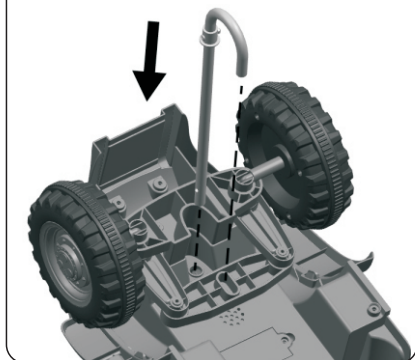

5. Installez la tige en J à l'endroit indiqué sur la photo.

Étape 6

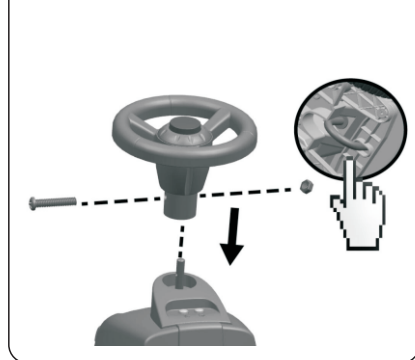

6. Desserrez d'abord le boulon et l'écrou du volant, puis placez le volant sur la tige en J, insérez le boulon et serrez l'écrou avec un tournevis (non inclus)

Étape 7



7. Assembler le siège, serrer avec une vis noire à l'aide d'un tournevis (non inclus).

Étape 8



8. Insérez le tuyau d'échappement, assurez-vous que le tuyau d'échappement est complètement positionné.

Assemblage du tracteur

Étape 1

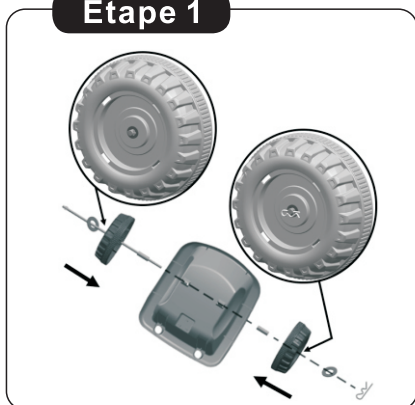

1. Insérez l'axe de la roue à travers la rondelle, la roue de la remorque et l'anneau en plastique dans la remorque, serrez à l'aide d'une goupille fendue.

Étape 2

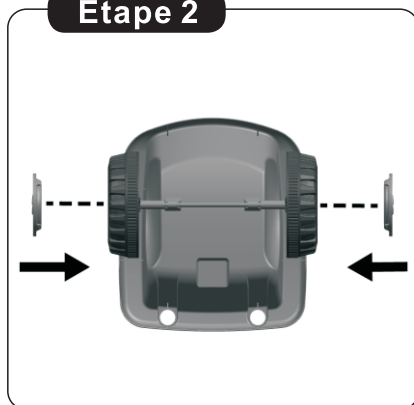

2. Placez les deux enjoliveurs de roue avant dans les deux roues de la remorque.

Étape 3

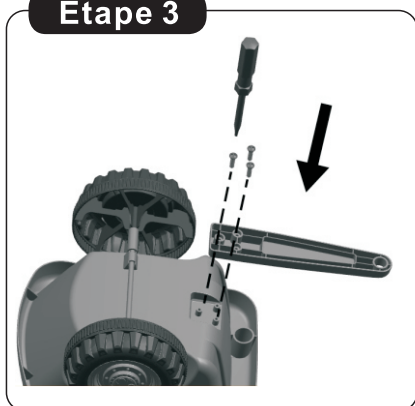

3. Assembler le connecteur de la remorque à l'aide d'un tournevis et de trois vis à tête plate (non fournies)

Étape 4

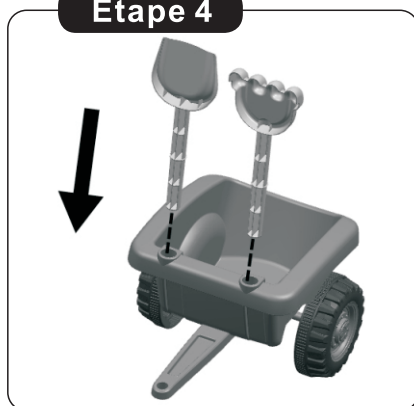

4. Insérez les deux jouets dans les trous prévus à cet effet dans la remorque.

Étape 5

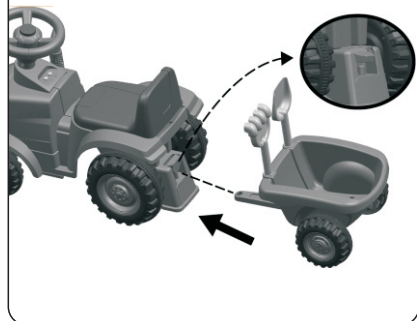

5. Ouvrir le verrou et connecter la remorque au tracteur.

Changement des piles

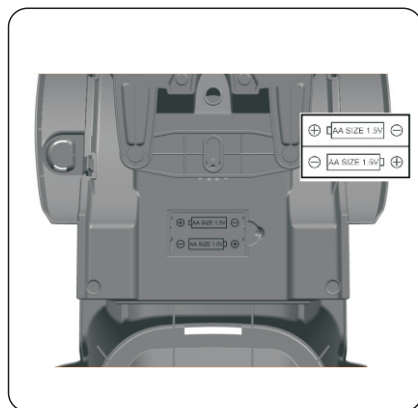
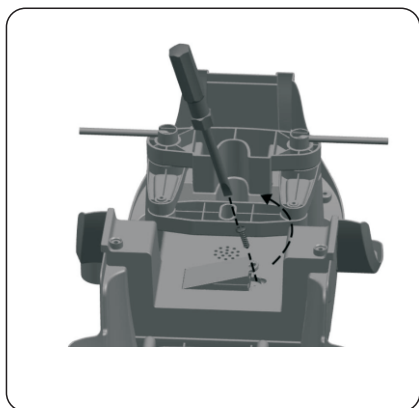

Retournez la carrosserie du tracteur et repérez le logement des piles. Dévissez la vis à l'aide d'un tournevis (non inclus). Placez 2 piles AA dans le logement des piles, puis serrez la vis à l'aide d'un tournevis (non inclus).

Fonction

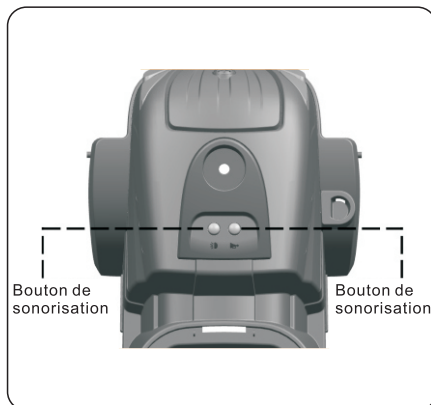
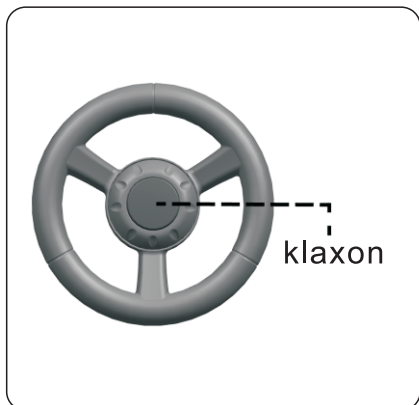

AIYAPLAY

IN240200103V01_UK_FR_DE_ES_IT

370-324V00



DE



***Geeignet für Kinder im Alter von 12-36 Monate .**

***Max. Gewicht: 25 kg.**

2022 Caterpillar. CAT, CATERPILLAR und ihre Designs und Marken sind registrierte Marken von Caterpillar Inc. Ningbo Prince Toys Co., Ltd., ein Lizenznehmer von Caterpillar Inc.

WICHTIG! SORGFÄLTIG LESEN UND FÜR SPÄTER NACHSCHLAGEN AUFBEWAHREN.

MONTAGEANWEISUNGEN

WARNUNG:

1. ERSTICKUNGSGEFAHR-Kleine Teile.
Die Montage darf nur von Erwachsenen vorgenommen werden, halten Sie Kinder fern.
2. Es ist unter der direkten Aufsicht eines Erwachsenen zu verwenden.
3. Erlauben Sie jeweils nur einem Kind es zu benutzen.
4. Verwenden Sie es bitte auf einer ebenen und sauberen Oberfläche. Es sollte niemals in der Nähe von Treppen, steile Auf-/ oder Abfahrten, hügeligen Straßen, Alleen, Schwimmbadbereichen, Straßen, auf Gras oder nassen Oberflächen oder anderen Gewässern benutzt werden.
5. Vor jeder Nutzung des Spielzeugautos sollte ein Erwachsener die Schrauben aller Teile überprüfen. Ziehen Sie bitte die Schraubenkappen fest, wenn sie locker sind. Überprüfen Sie vor jeder Fahrt alle Befestigungselemente.
6. Es sollten immer Schuhe und eine geeignete Schutzausrüstung getragen werden. Während der Fahrt sollte immer ein gemäß der örtlichen Norm zugelassener Helm getragen werden, dessen Kinnriemen fest sitzt.
7. Nicht während der Dämmerung, bei Nacht oder bei eingeschränkter Sicht mit dem Produkt fahren.
8. Beachten Sie stets die örtlichen Gesetze und Vorschriften.



WARTUNG & PFLEGE

- A. Bewahren Sie alle Anweisungen und Teile, die sich auf dieses Produkt beziehen, zur späteren Verwendung auf.
- B. Prüfen Sie es regelmäßig auf Beschädigungen und ob alle Schrauben fest angezogen sind.
- C. Prüfen Sie, ob der Sitz sicher befestigt ist.
- D. Schmieren Sie die Kette so oft wie nötig.
- E. Prüfen Sie regelmäßig den Reifendruck.

Handhabung der Batterie:

1. Die Batterie darf nur von Erwachsenen gehandhabt werden.
2. Entfernen Sie stets verbrauchte Batterien.
3. Verwenden Sie nur Batterien der Größe AA.
4. Es werden Alkalibatterien empfohlen.
5. Entnehmen Sie die Batterien immer, wenn das Gerät über einen längeren Zeitraum nicht benutzt wird.
6. Wenn Sie neue Batterien einlegen, ersetzen Sie immer alle Batterien.
7. Die alten und neuen Batterien dürfen nicht vermischt werden.
8. Alkali-, Standard- (Carbon-Zink) oder wiederaufladbare (Nickel-Cadmium) Batterien nicht mischen.
9. Die Batterien dürfen nicht ins Feuer entsorgt werden, da sie explodieren oder auslaufen können.
10. Nicht wiederaufladbare Batterien dürfen nicht wieder aufgeladen werden
11. Akkus sind vor dem Aufladen aus dem Spielzeug zu entfernen
12. Akkus dürfen nur unter Aufsicht von Erwachsenen geladen werden
13. Die Batterien sind polrichtig einzulegen.
14. Die Stromversorgungsklemmen dürfen nicht kurzgeschlossen werden.

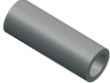
KOMPONENTENLISTE

<p>1. Karosserie 1 Stück</p> 	<p>2. Lenkrad 1 Stück</p> 	<p>3. Anhänger 1 Stück</p> 
<p>4. Sitz 1 Stück</p> 	<p>5. Auspuffrohr 1 STÜCK</p> 	<p>6. Vorderrad 2 Stück avant 2pcs</p> 
<p>7. Radkappe hinten 2 Stück</p> 	<p>8. Hinterrad 2 Stück</p> 	<p>9. Anhängerrad 2 Stück</p> 
<p>10. Vorderradkappe 4 Stück</p> 	<p>11. Kippschutz Ablage 1 Stück</p> 	<p>12. Anhängerstecker 1 Stück</p> 
<p>13. J-Stock 1 Stück</p> 	<p>14. Radachse 2 Stück</p> 	<p>15. Ring 6 Stück</p> 
<p>16. Unterlegscheibe 7 Stück (1 Ersatzteil)</p> 	<p>17. Splint 5 Stück (1 Ersatzteil)</p> 	<p>18. Schraube schwarz 2 Stück (1 Ersatzteil)</p> 
<p>19. Schraube silber 4 Stück (1 Ersatzteil)</p> 	<p>20. Spielzeug 2 Stück</p> 	

Montage des Traktors

Schritt 1

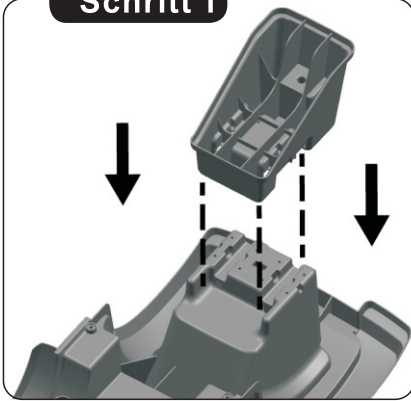

1. Setzen Sie den Kippschutz in das Heck der Traktorkarosserie.

Schritt 2

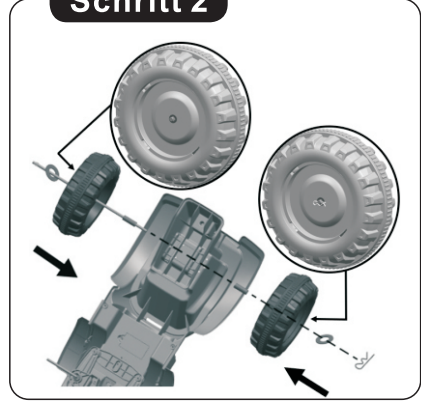

2. Setzen Sie die Radachse durch die Unterlegscheibe, das Hinterrad und den Kunststoffring in die Karosserie ein und ziehen Sie sie mit einem Splint fest.

Schritt 3

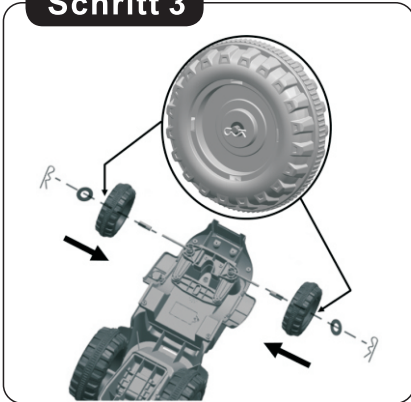

3. Montieren Sie die beiden Vorderräder, setzen Sie den Kunststoffring, das Rad und die Unterlegscheibe ein und ziehen Sie sie mit einem Splint fest.

Schritt 4

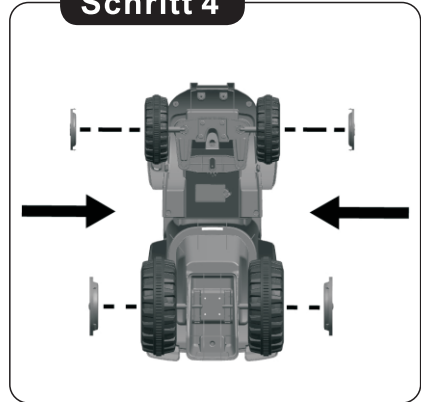

4. Setzen Sie die beiden vorderen Radkappen auf die Vorderräder, die beiden hinteren Radkappen auf die Hinterräder.

Schritt 5

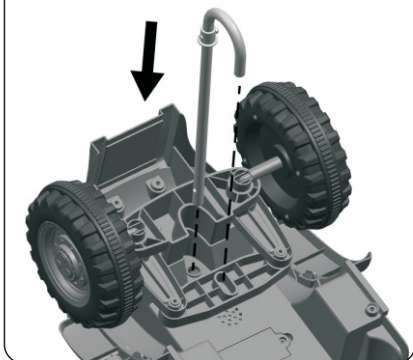

5. Montieren Sie den J-Stock an der zugewiesenen Stelle wie abgebildet.

Schritt 6

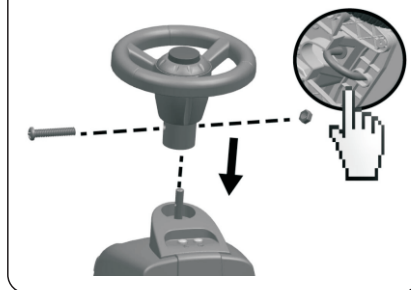

6. Lösen Sie zuerst die Schraube und die Mutter im Lenkrad, setzen Sie dann das Lenkrad über den J-förmigen Stock, setzen Sie die Schraube und ziehen Sie die Mutter mit einem Schraubendreher (nicht im Lieferumfang enthalten) fest.

Schritt 7



7. Montieren Sie den Sitz, ziehen Sie die schwarze Schraube mit einem Schraubendreher fest (nicht im Lieferumfang enthalten).

Schritt 8



8. Setzen Sie das Auspuffrohr ein, stellen Sie sicher, dass das Auspuffrohr vollständig sitzt.

Montage des Traktors

Schritt 1

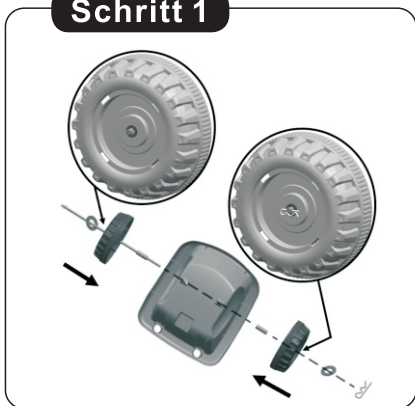

1. Stecken Sie die Radachse durch die Unterlegscheibe, das Anhängerrad und den Kunststoffring in den Anhänger, ziehen Sie sie mit einem Splint fest.

Schritt 2

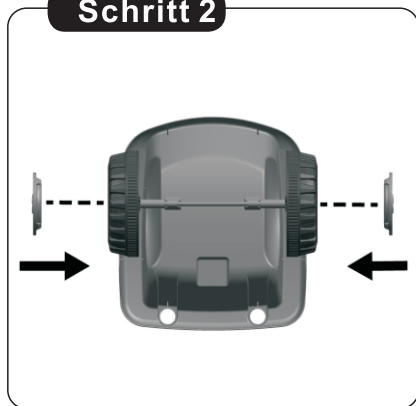

2. Setzen Sie die beiden vorderen Radkappen auf beide Anhängerräder.

Schritt 3

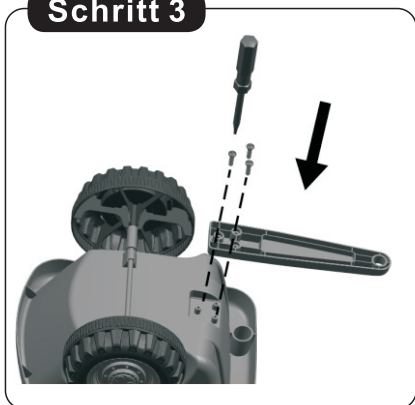

3. Montieren Sie den Anhängeranschluss mit drei Splitterschrauben mit einem Schraubendreher (nicht im Lieferumfang enthalten)

Schritt 4

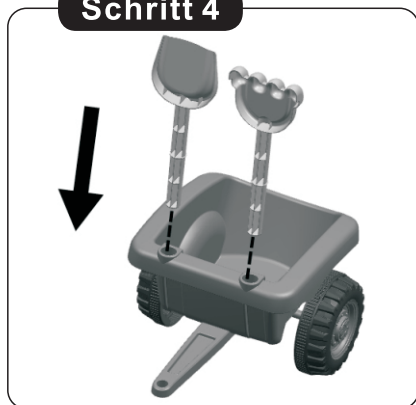

4. Stecken Sie die beiden Spielzeuge in die Löcher des Anhängers.

Schritt 5

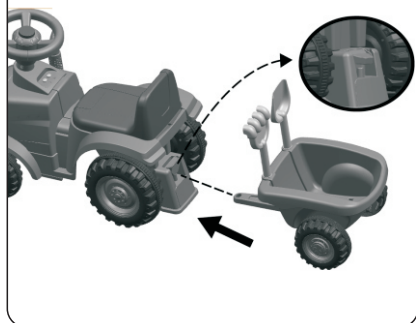

5. Öffnen Sie das Schloss und verbinden Sie den Anhänger mit dem Traktor.

Batteriewechsel

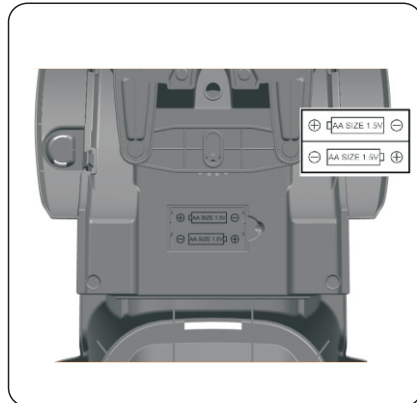
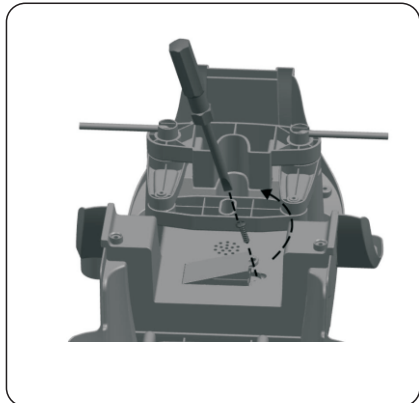

Drehen Sie die Traktorkarosserie um, und suchen Sie das Batteriefach. Lösen Sie die Schraube mit einem Schraubendreher (nicht im Lieferumfang enthalten), legen Sie 2 AA-Batterien in das Batteriefach und ziehen Sie die Schraube mit einem Schraubendreher fest (nicht im Lieferumfang enthalten).

Funktion

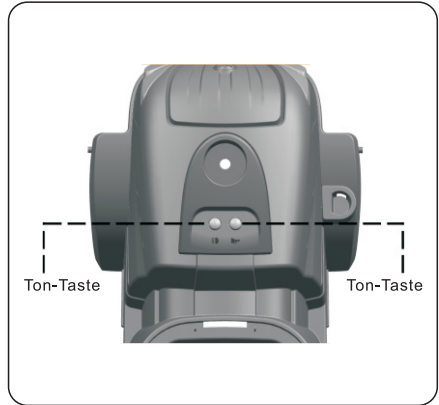
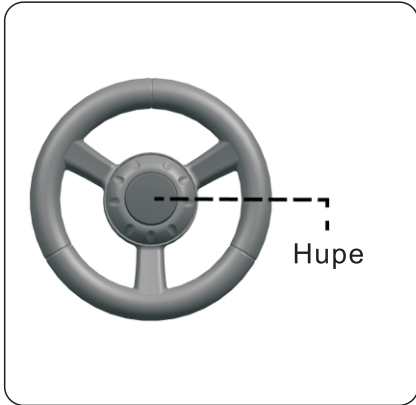

AIYAPLAY

IN240200103V01_UK_FR_DE_ES_IT

370-324V00



12-36
mesi

IT



- * **Adatto a bambini di 12-36 mesi.**
- * **Peso massimo: 25 kg.**

2022 Caterpillar. CAT, CATERPILLAR e i loro design e marchi sono marchi registrati di Caterpillar Inc. Ningbo Prince Toys Co., Ltd., un licenziatario di Caterpillar Inc.

IMPORTANTE! CONSERVARE IL PRESENTE MANUALE PER FUTURO RIFERIMENTO E LEGGERLO ATTENTAMENTE.

ISTRUZIONI DI ASSEMBLAGGIO

AVVERTENZA:

1. RISCHIO DI SOFFOCAMENTO

Consentire l'installazione solo agli adulti, tenere lontani i bambini.

2. Da utilizzare sotto la diretta supervisione di un adulto.

3. Consentire l'uso un bambino alla volta.

4. Si prega di utilizzare su una superficie in piano e pulita. Non usare mai vicino a gradini, passi carrai in pendenza, strade in collina, vicoli, piscine, strade, su erba o superfici bagnate o altre fonti d'acqua.

5. Prima di guidare ogni volta il veicolo, l'adulto dovrebbe ispezionare le viti di tutte le parti, e stringere i dadi in caso di allentamento. Stringere tutti i dispositivi di fissaggio prima di ogni viaggio.

6. Indossare sempre scarpe e dispositivi di protezione adeguati. Indossare sempre un casco approvato dalla normativa locale durante la guida, con il cinturino fissato saldamente.

7. Non guidare il prodotto al crepuscolo, di notte o in momenti di visibilità limitata.

8. Rispettare sempre le leggi e le normative locali.

MANUTENZIONE & CURA

A. Conservare tutte le istruzioni e le parti relative a questo prodotto per riferimenti futuri.

B. Verificare regolarmente la presenza di danni e che tutte le viti siano strette saldamente.

C. Verificare che il sedile sia fissato in sicurezza.

D. Lubrificare la catena tutte le volte che è necessario.

E. Controllare regolarmente la pressione degli pneumatici.

Trattamento Batterie:

1. Le batterie devono essere trattate solo da adulti.

2. Rimuovere sempre le batterie esauste.

3. Solo uso delle batterie AA.

4. Si consigliano batterie alcaline.

5. Rimuovere sempre le batterie quando il prodotto non verrà utilizzato per un lungo periodo di tempo.

6. Quando si sostituiscono con nuove batterie, sostituire sempre tutte le batterie.

7. Non mescolare batterie vecchie e nuove.

8. Non mescolare batterie alcaline, standard (carbonio-zinco) o ricaricabili (nichel- cadmio).

9. Non smaltire le batterie in fiamme perché le batterie possono esplodere o perdere.









10. Le batterie non ricaricabili non devono essere ricaricate.

11. Le batterie ricaricabili devono essere rimosse dal giocattolo prima di essere ricaricate.

12. Le batterie ricaricabili devono essere ricaricate solo sotto la supervisione degli adulti.

13. Le batterie devono essere inserite con la corretta polarità.

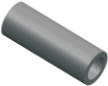
EIENCO DEI COMPONENTI

<p>1. Corpo 1 pz</p> 	<p>2. Volante 1 pz</p> 	<p>3. Rimorchio 1 pz</p> 
<p>4. Sedile 1 pz</p> 	<p>5. Tubo di scarico 1 pz</p> 	<p>6. Ruota anteriore 2 pz</p> 
<p>7. Coperchio della Ruota posteriore 2 pz</p> 	<p>8. Ruota posteriore 2 pz</p> 	<p>9. Ruota Rimorchio 2 pz</p> 
<p>10. Coperchio della Ruota anteriore 4 pz</p> 	<p>11. Supporto anti caduta 1 pz</p> 	<p>12. Connettore rimorchio 1 pz</p> 
<p>13. Bastoncino a forma J 1 pz</p> 	<p>14. Asse ruota 2 pz</p> 	<p>15. Anello 6 pz</p> 
<p>16. Rondella 7 pz (1 replacement piece)</p> 	<p>17. Coppiglia 5 pz (1 pezzo di sostituzione)</p> 	<p>18. vite nera 2 pz (1 pezzo di sostituzione)</p> 
<p>19. Vite d'argento 4 pz (1 pezzo di sostituzione)</p> 	<p>20. Giocattolo 2 pz</p> 	

Assemblaggio Trattore

Passaggio 1

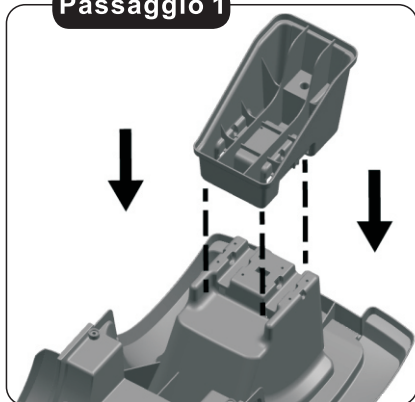

1. Posizionare il supporto anti-caduta nella parte posteriore del corpo del trattore.

Passaggio 2

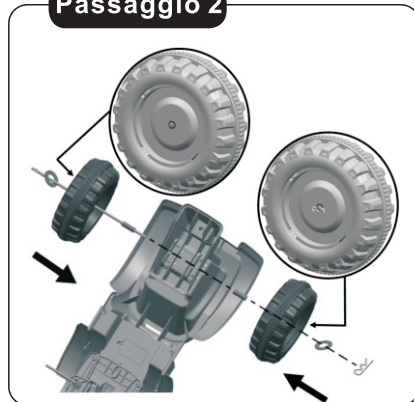

2. Inserire l'asse della ruota attraverso la rondella, montare la ruota posteriore, l'anello di plastica nel corpo, fissare con una coppiglia.

Passaggio 3

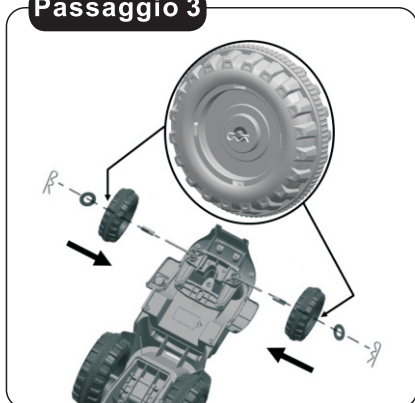

3. Montare le due ruote anteriori, inserire l'anello di plastica, la ruota e la rondella, fissare con un perno di cotter.

Passaggio 4

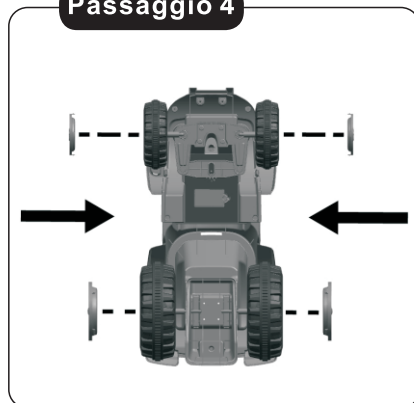

4. Posizionare i due coperchi delle ruote anteriori nelle ruote anteriori e i due coperchi delle ruote posteriori nelle ruote posteriori.

Passaggio 5

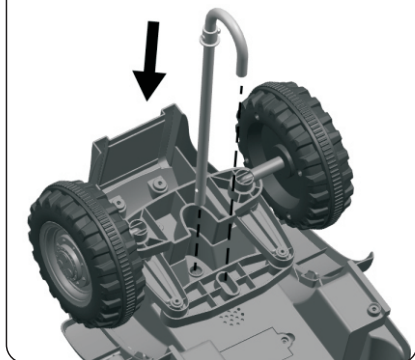

5. Installare il bastoncino a forma J nella posizione assegnata come mostrato nell'immagine.

Passaggio 6

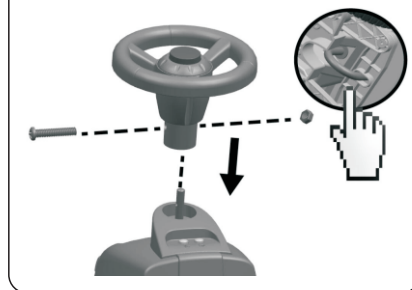

6. Allentare prima il bullone e il dado nel volante, e poi posizionare il volante sul bastoncino a forma J, inserire il bullone e stringere il dado con un cacciavite (non incluso).
and tighten the nut with a screwdriver(not included)

Passaggio 7



7. Montare il sedile, stringere con una vite nera da un cacciavite (non incluso).

Passaggio 8



8. Inserire il tubo di scarico, assicurarsi che il tubo di scarico sia completamente piantato.

Assemblaggio Trattore

Passaggio 1

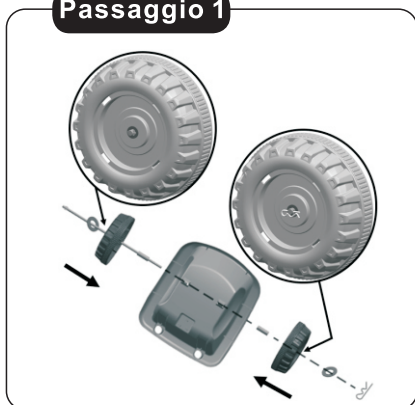

1. Inserire l'asse della ruota attraverso la rondella, montare la ruota del rimorchio, l'anello di plastica nel rimorchio, fissare con una coppia.

Passaggio 2

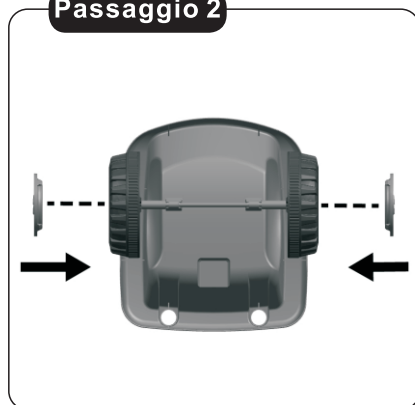

2. Posizionare i due coperchi delle ruote anteriori nelle due ruote del rimorchio.

Passaggio 3

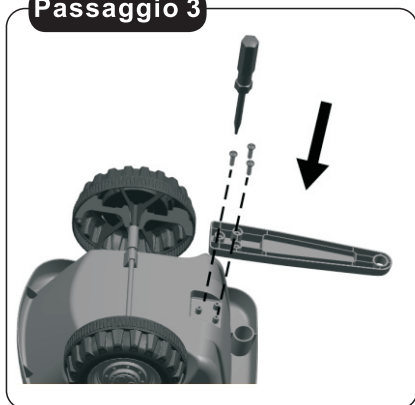

3. Montare il connettore del rimorchio con tre viti d'argento da un cacciavite (non incluso).

Passaggio 4



4. Inserire i due giocattoli nei fori del rimorchio.

Passaggio 5

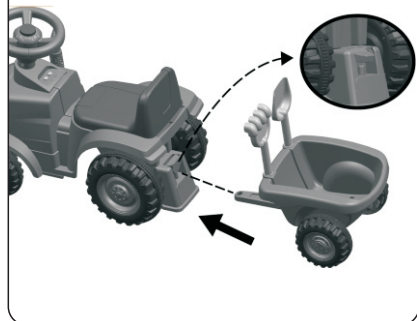

5. Aprire la serratura e collegare il rimorchio con il trattore.

Sostituzione della batteria

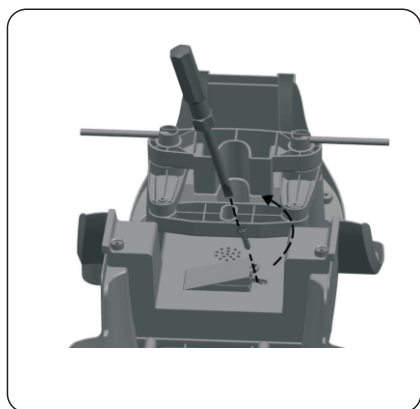

Capovolgere il corpo del trattore e trovare il vano della batteria. Allentare la vite con un cacciavite (non incluso). Sostituire con 2 batterie AA nel vano, e poi serrare la vite con un cacciavite (non incluso).

Funzionamento

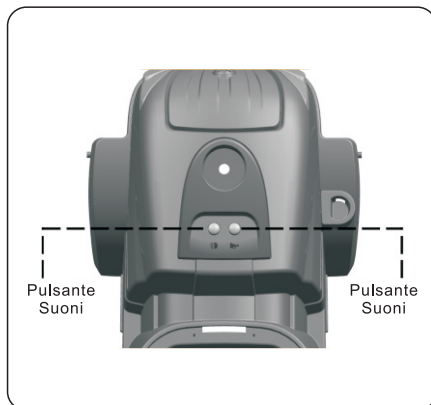
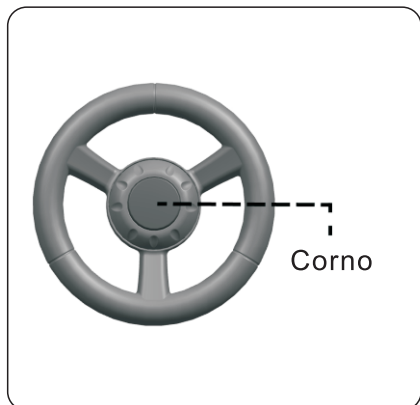

AIYAPLAY

IN240200103V01_UK_FR_DE_ES_IT

370-324V00



ES



***Adecuado para los niños de 12 a 36 meses .**

***Peso máximo: 25 kg.**

2022 Caterpillar. CAT, CATERPILLAR y sus diseños y marcas son marcas registradas de Caterpillar Inc. Ningbo Prince Toys Co., Ltd., un licenciario de Caterpillar Inc.

IMPORTANTE, LEA Y GUARDE PARA FUTURAS REFERENCIAS.

INSTRUCCIONES DE MONTAJE

ADVERTENCIA:

1. PELIGRO DE ASFIXIA: Incluidas piezas pequeñas.
La instalación sólo se puede realizar por los adultos, mantenga a los niños alejados al instalar el scooter.
2. El producto debe ser utilizado bajo la supervisión directa de un adulto.
3. Sólo se permita que un/una niño/a utilice este scooter a la vez.
4. Utilice este scooter sobre una superficie plana y limpia. Nunca lo utilice cerca de escalones, caminos de entrada inclinados, caminos de colinas, callejones, áreas de piscinas, carreteras, sobre césped o superficies mojadas u otros lugares cerca de cuerpos de agua.
5. Antes de conducir este scooter de juguete cada vez, el adulto debe inspeccionar los tornillos de cada pieza del scooter. Si la cubierta de rosca está floja, apriétela bien. Fije todos los sujetadores bien antes de cada uso.
6. Siempre lleve calzado y equipo de protección adecuado al conducir este scooter. Siempre use un casco aprobado por las normas locales al conducir, y fije la correa de la barbilla bien abrochada.
7. No utilice este scooter al anochecer, de noche o en momentos con visibilidad limitada.
8. Siempre cumpla con las leyes y regulaciones locales.













MANTENIMIENTO Y CUIDADO

- A. Guarde todas las instrucciones y piezas relativas juntas con este producto para las referencias futuras.
- B. Compruebe regularmente para asegurarse de que no haya daños y que todos los tornillos estén apretados firmemente.
- C. Compruebe que el asiento del scooter esté abrochado firmemente.
- D. Lubrique la cadena frecuentemente si sea necesario.
- E. Compruebe regularmente la presión de los neumáticos.

Disposición de pilas:

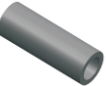
1. Las pilas deben manipularse sólo por adultos.
2. Siempre retire las pilas agotadas.
3. Utilice sólo pilas de tamaño AA.
4. Se recomiendan las pilas alcalinas.
5. Siempre retire las pilas cuando la unidad no vaya a ser utilizada por un período prolongado de tiempo.
6. Cuando reemplaza las pilas, siempre reemplace todas las pilas.
7. No mezcle las pilas viejas con las nuevas.
8. No mezcle las pilas alcalinas estándar (carbono-zinc) con las recargables (níquel-cadmio).
9. No tire las pilas al fuego, ya que pueden explotar o tener fugas.
10. Las pilas no recargables no deben ser recargadas.
11. Las pilas recargables deben ser retiradas del juguete antes de ser cargadas.
12. Las pilas recargables sólo deben cargarse bajo la supervisión de un adulto.
13. Las pilas deben colocarse con la polaridad correcta.
14. Los terminales de alimentación no deben ser cortocircuitados.

LISTA DE COMPONENTES

<p>1.Cuerpo 1pieza</p> 	<p>2. Volante 1pieza</p> 	<p>3.Remolque 1pieza</p> 
<p>4.Asiento 1pieza</p> 	<p>5.Tubo de escape 1pieza</p> 	<p>6.Rueda delantera 2piezas</p> 
<p>7. Tapa de la rueda trasera 2piezas</p> 	<p>8.Rueda trasera 2piezas</p> 	<p>9.Rueda de remolque 2piezas</p> 
<p>10.Tapa de rueda delantera 4piezas</p> 	<p>11. Armazón anti-vuelco 1pieza</p> 	<p>12.Conector de remolque 1pieza</p> 
<p>13. Palo en forma de J 1pieza</p> 	<p>14. Eje de rudas 2piezas</p> 	<p>15.Anillo 6piezas</p> 
<p>16.Arandela 7piezas (1 pieza de repuesto)</p> 	<p>17.Claveta 5piezas (1 pieza de repuesto)</p> 	<p>18.Tornillo negro 2piezas (1 pieza de repuesto)</p> 
<p>19.Tornillo plateado 4piezas (1 pieza de repuesto)</p> 	<p>20.Juguete 2piezas</p> 	

Ensamblaje del Tractor

Paso 1

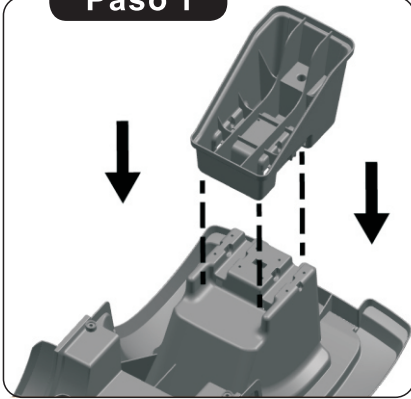

1. Coloque el armazón anti-vuelco detrás del cuerpo del tractor.

Paso 2

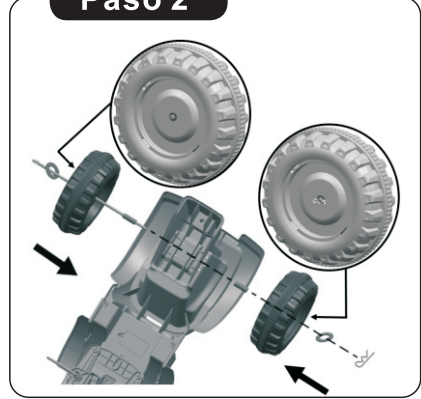

2. Inserte el eje de la rueda a través de la arandela, la rueda trasera, el anillo de plástico en el cuerpo, apriételo con una chaveta

Paso 3

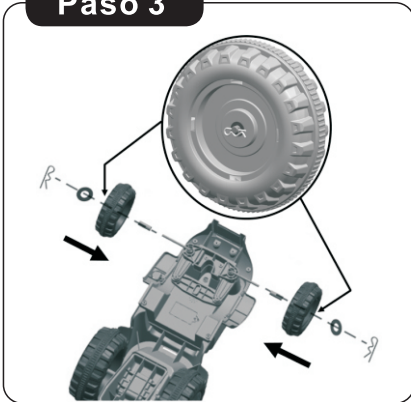

3. Monte las dos ruedas delanteras, inserte el anillo de plástico, la rueda y la arandela, y apriételos con una chaveta.

Paso 4

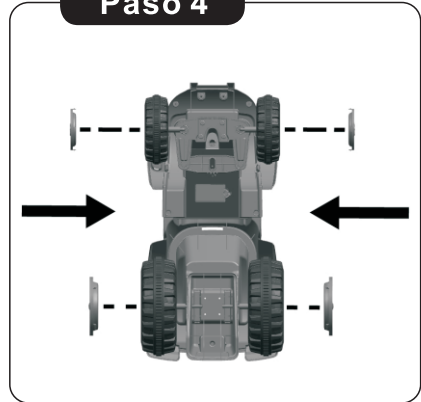

4. Coloque las dos tapas de las ruedas delanteras en las ruedas delanteras, y las dos tapas de las ruedas traseras en las ruedas traseras.

Paso 5

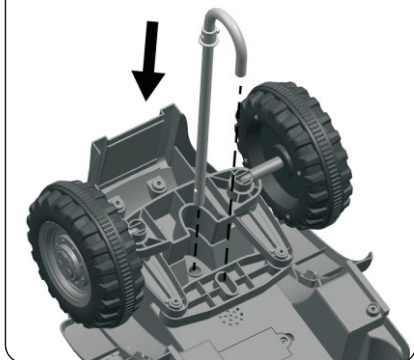

5. Instale el palo en forma de J en el lugar asignado como en la imagen.

Paso 6

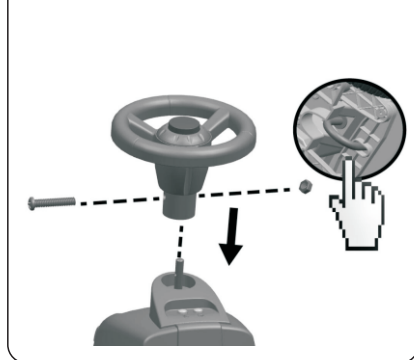

6. Afloje primero el tornillo y la tuerca en el volante, luego coloque el volante sobre el palo en forma de J, inserte el tornillo y apriete la tuerca con un destornillador (no incluido)

Paso 7



7. Monte el asiento, y apriete el tornillo negro con un destornillador (no incluido).

Paso 8



8. Inserte el tubo de escape, asegúrese de que el tubo de escape esté completamente asentado.

Ensamblaje del Tractor

Paso 1

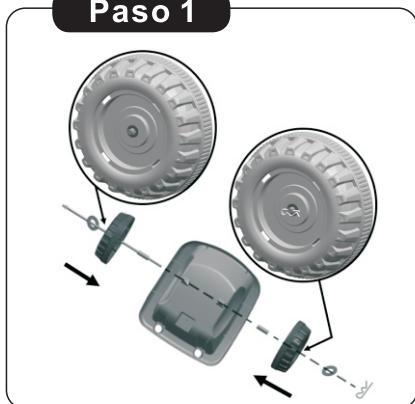

1. Inserte el eje de la rueda a través de la arandela, la rueda del remolque, el anillo de plástico en el remolque, apriételo con una chaveta.

Paso 2

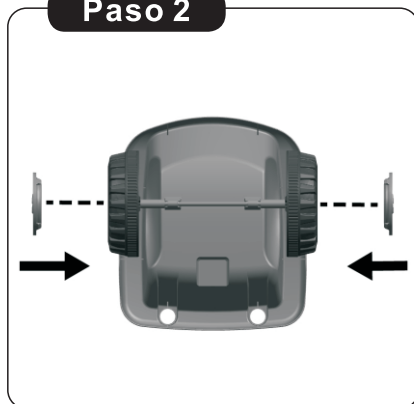

2. Coloque las dos tapas de las ruedas delanteras en las dos ruedas del remolque.

Paso 3

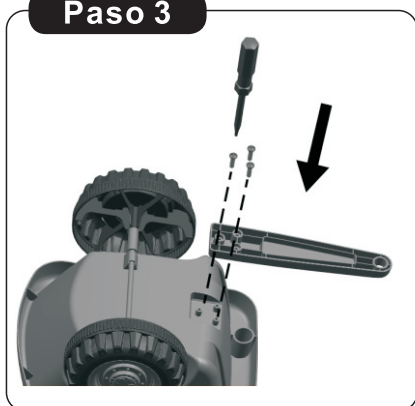

3. Monte el conector del remolque con tres tornillos plateados usando un destornillador (no incluido)

Paso 4



4. Inserte los dos juguetes en los agujeros del remolque.

Paso 5

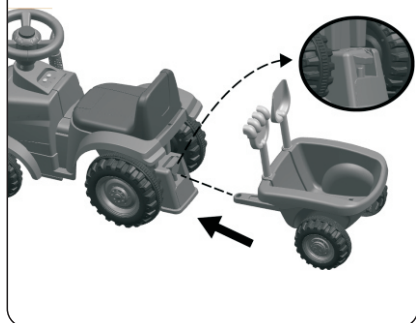

5. Abra la cerradura y conecte el remolque con el tractor.

Reemplazo de pilas

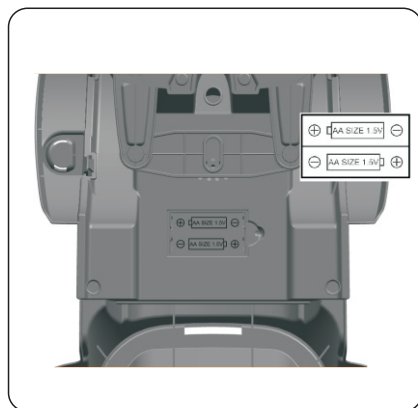
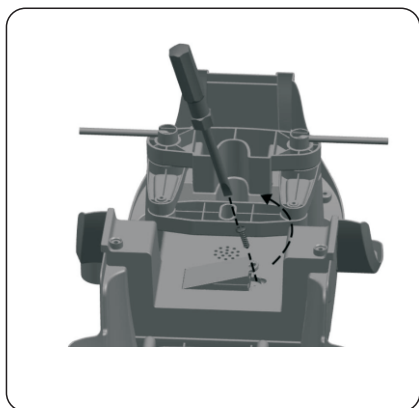

Gire el cuerpo del tractor y localice el compartimento de las pilas. Afloje el tornillo con un destornillador (no incluido). Coloque 2 pilas AA en el compartimento de las pilas y apriete el tornillo con un destornillador (no incluido).

Función

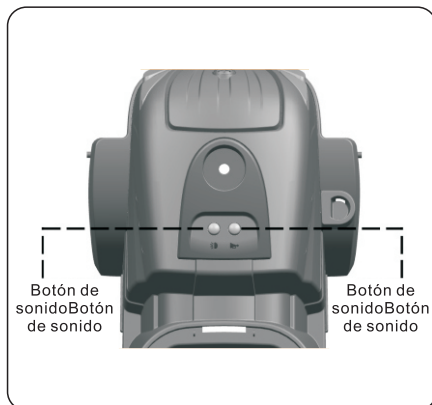
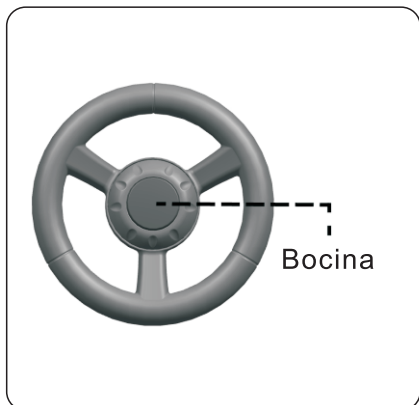

UK

If you have any questions, please contact our customer care center.

Our contact details are below:



0044-800-240-4004



enquiries@mhstar.co.uk

IMPORTER ADDRESS:

MH STAR UK LTD
Unit 27, Perivale Park,
Horsenden lane South
Perivale, UB6 7RH
MADE IN CHINA

ES

Si tiene alguna pregunta, comuníquese con nuestro Centro de Atención al Cliente. Nuestros datos de contacto son los siguientes:



0034-931294512



atencioncliente@aosom.es

IMPORTADOR:

SPANISH AOSOM, S.L.
C/ ROC GROS, N° 15. 08550, ELS HOSTALETS DE
BALENYÀ, SPAIN.
B66295775
WWW.AOSOM.ES
ATENCIONCLIENTE@AOSOM.ES
TEL: 931294512
HECHO EN CHINA

FR

Si vous avez la moindre question, veuillez contacter notre centre d'assistance à la clientèle.

Nos coordonnées sont les suivantes:



0033-1-84166106



aosom@mhfrance.fr

Importé par:

MH France
2, rue Maurice Hartmann
92130 Issy-les-Moulineaux
France
Fabriqué en Chine

PT

Se tiver alguma dúvida, por favor contacte o nosso Centro de Atendimento ao Cliente. Os nossos dados de contacto são os seguintes:



0034-931294512



info@aosom.pt.

IMPORTADOR:

SPANISH AOSOM, S.L.
C.ROC GROS N.15, 08550. ELS HOSTALETS DE BALENYÀ
TEL: 931294512 (SEG-SEX DAS 7:30H ÀS 16:30H)
INFO@AOSOM.PT
WWW.AOSOM.PT

DE

Wenn Sie Fragen haben, wenden Sie sich bitte an unser Kundendienstzentrum.

Unsere Kontaktdaten stehen unten:



0049-0(40)-88307530



service@aosom.de

ADRESSE DES IMPORTEUR:

MH Handel GmbH
Wendenstraße 309
D-20537 Hamburg
Germany
IN CHINA HERGESTELLT

IT

In caso di dubbio, si prega di contattare il nostro centro assistenza clienti. I nostri dettagli di contatto sono di seguito:



0039-0249471447



clienti@aosom.it

IMPORTATO DA:

AOSOM Italy srl
Centro Direzionale Milanofiori
Strada 1 Palazzo F1
20057 Assago (MI)
P.I.: 08567220960
FATTO IN CINA

