



EN

IN240200105V01_US_CA

370-326V80



18-36
months

ATV Electric Ride-on

Installation and operation manual



CAUTION:

- This package contains small parts – keep away from children.
- Adult assembly required.
- Before giving to children, remove all plastic bags and tyre packaging.
- Protective equipment recommended.
- Not to be used in traffic.
- Keep this manual for future reference.



WARNING

**ADULT ASSEMBLY
REQUIRED.**











IMPORTANT, RETAIN FOR FUTURE REFERENCE: READ CAREFULLY

ASSEMBLY INSTRUCTION

I . SPECIFICATIONS.

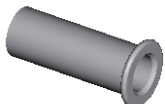
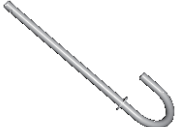
Suitable Ages	18-36 months
Product Dimensions	65.5X38.5X43.5cm
Maximum Weight	25 kgs
Speed	2.8 km/h
Motor	30W
Charger	Input: AC 100V - 240V
	Output:DC8V/500mA
Battery	6V4A
Operating Ambient Temperature	0 - 40°C

II . Components List

1.1 x Body 	2. 1 x Handle 	3. 2 x Front wheel 	4. 2 x Rear wheel 
5. 4 x Wheel cover 	6. 1 x Bumper 	7. 1 x Motor 	8. 1 x Spacer 
9. 1 x J stick 	10. 1 x Axle 	11. 5 x Cotter pin (one replacement) 	12. 7 x Washer (one replacement) 
13. 1 x Charger 			

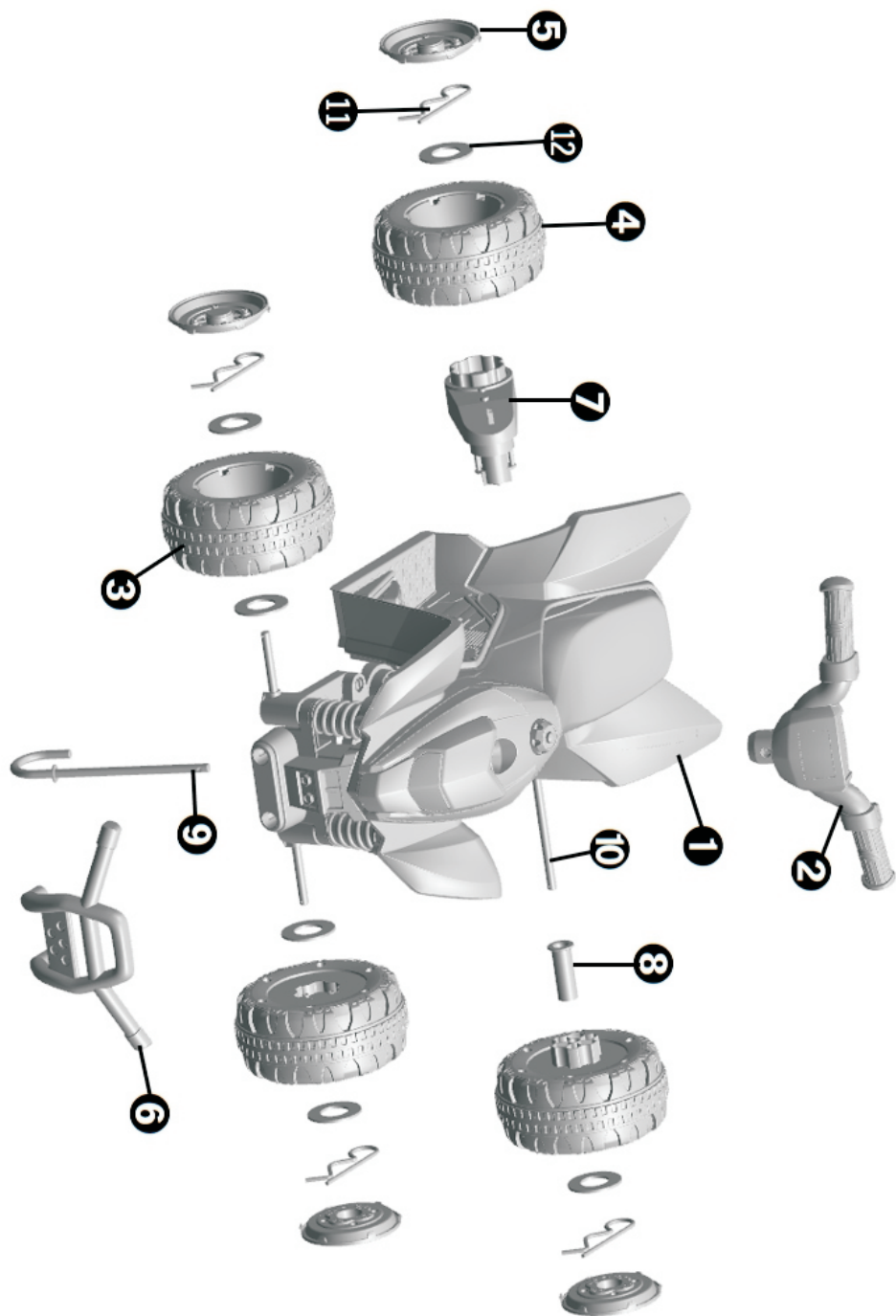

III. Assembly Instructions

< 1 >

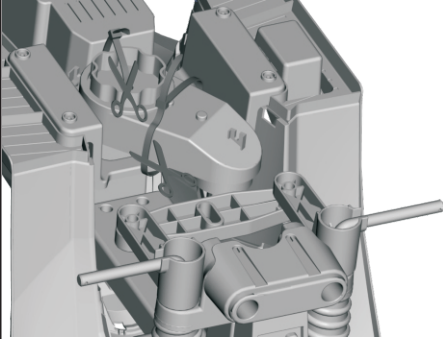

< 2 >

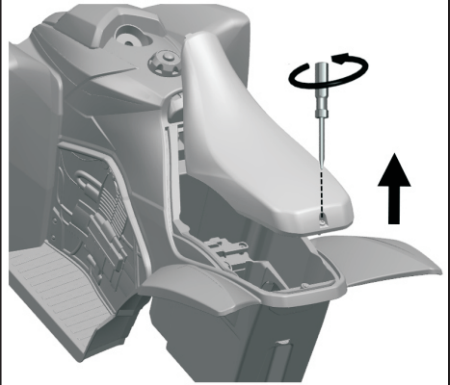

< 3 >

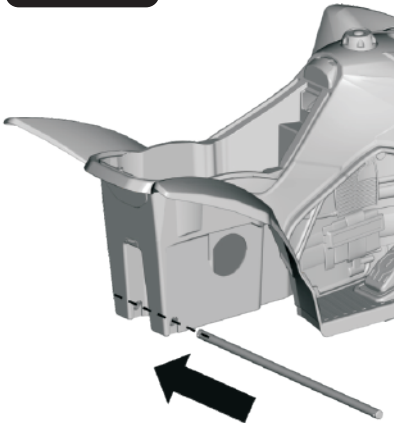

< 4 >

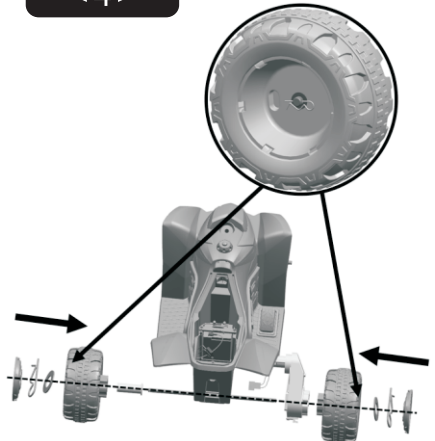

< 5 >

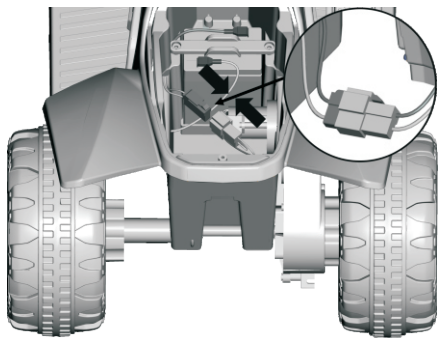

< 6 >

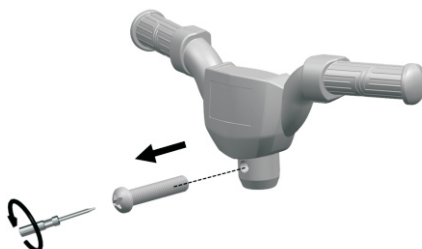

< 7 >

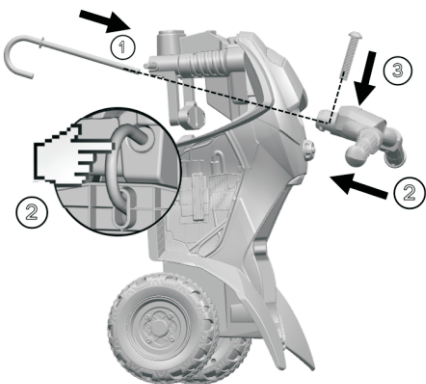

< 8 >

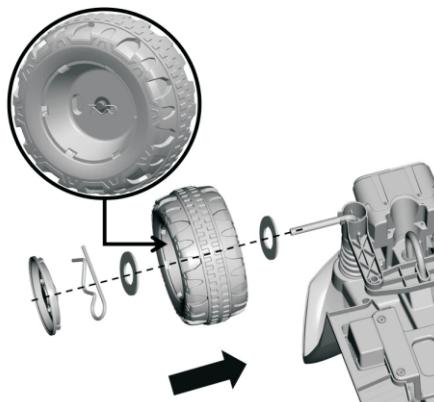

< 9 >

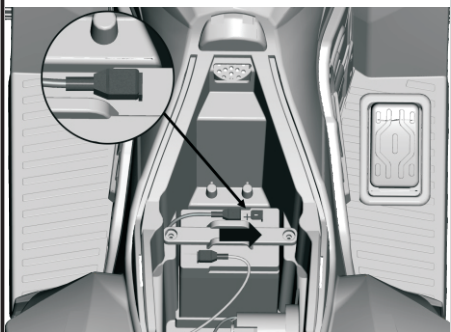

< 10 >

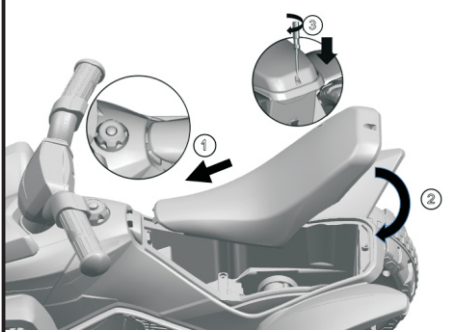

< 11 >

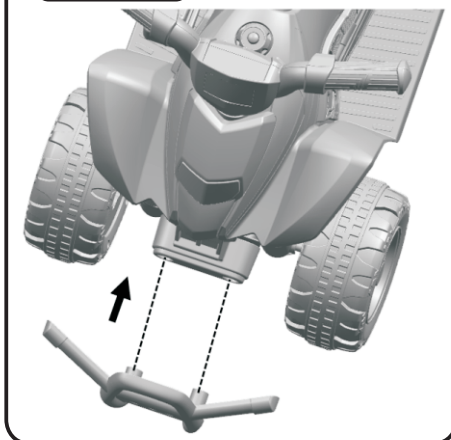

IV. Function and Operation

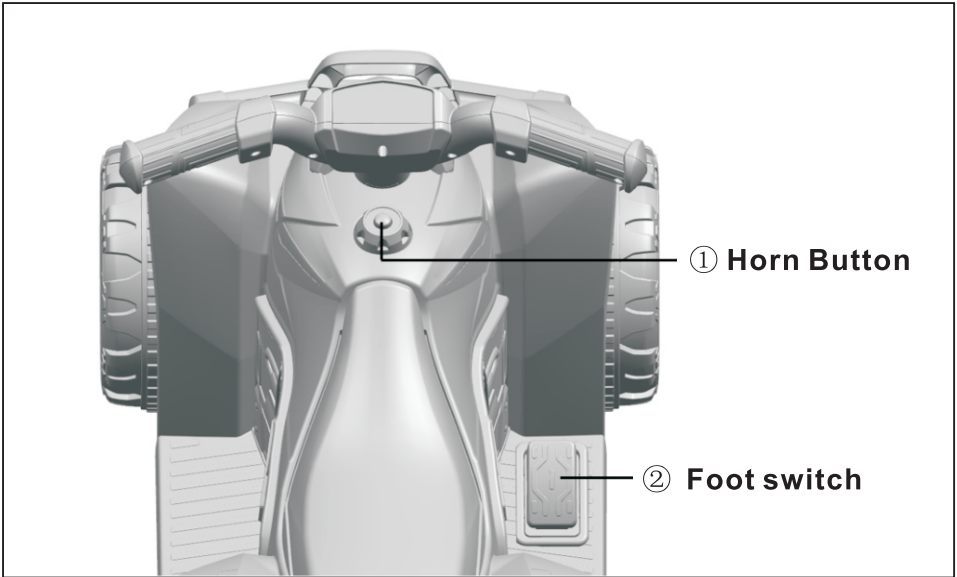

V. Battery and charger operation guide

1. The charging socket is located at the rear.
2. Only use the provided or recommended battery and charger.
3. Do not play with the charger and battery.
4. Batteries must only be charged by adults.
5. The battery must be fully charged before first use. Charge for 9-10 hours – do not exceed 15 hours.
6. When charging, it is normal for charger and battery to be warm.

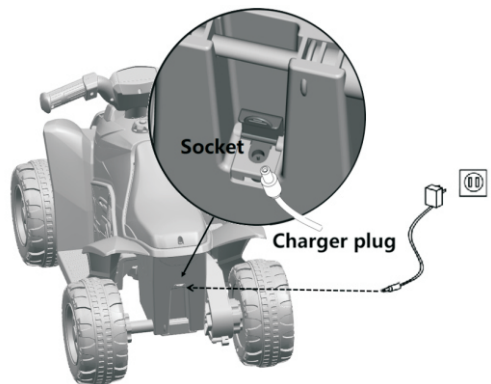

VI.WARNING.

1.Battery warning:

- 1) When storing the car for a long time, fully charge the battery, then turn off the power. The battery should be recharged once every other month – minimising the risk of shortening its lifespan.
- 2) When installing the battery, the positive and negative poles must be correctly connected. Short circuiting of positive and negative poles could damage the product.

2.Product warning

- 1) Pre-assembled parts can be sharp – product assembly must be done by an adult. Keep parts away from small children.
- 2) To avoid suffocation, keep plastic bags away from children. Dispose of all bags immediately.
- 3) When children ride this product, adult supervision is required.
- 4) This car is to be driven on a flat and even ground. Do not drive on public roads, steep hills or near swimming pools.
- 5) Wear shoes when using this product. Take protective measures, such as fastening the seatbelt and wearing a helmet, gloves, kneepads etc.
- 6) Regularly check the battery, charger, wire, plug, casing and other parts. If there are any damages, do not use the product until it has been repaired.
- 7) This product can fit one child at a time. The maximum load is 25 kg – do not exceed this limit.
- 8) Keep this product away from open flames.
- 9) Keep is manual for future reference.

 **WARNING**

- Adult supervision required – minimising the risk of injury.
- Do not use on roads, near motor vehicles, slopes, swimming pools or areas where there is water.
- Wear shoes when using this ride-on.
- Can only be used by one child at a time.
- Before this product is assembled, keep it away from children. There could be small and sharp parts, which could be dangerous.
- This product must be assembled by an adult.

 **WARNING**

Do not mix alkaline, standard (carbon-zinc) or rechargeable (nickel-cadmium) batteries.

 **WARNING**

Protective equipment should be worn. Do not ride in traffic.



FR

IN240200105V01_US_CA

370-326V80



18-36
months

Voiture Autoportée Électrique

Manuel d'installation et d'utilisation



ATTENTION:

- Cet emballage présente de petites pièces.
- L'assemblage par un adulte est requis.
- Avant de le remettre aux enfants, retirez tous les sacs en plastique et les emballages des pneus.
- Équipement de protection recommandé.
- Ne doit pas être utilisé dans la circulation.
- Conservez ce manuel pour toute consultation ultérieure.



AVERTISSEMENT ASSEMBLAGE PAR UN ADULTE REQUIS.













**IMPORTANT : LIRE ATTENTIVEMENT, À CONSERVER POUR TOUTE
CONSULTATION ULTÉRIEURE**

INSTRUCTIONS D'ASSEMBLAGE

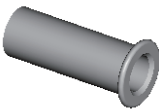
I.SPÉCIFICATIONS.

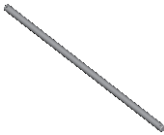
Âge recommandé	18-36 mois
Dimensions du produit	65.5X38.5X43.5cm
Poids maximum	25 kgs
Vitesse	2.8 km/h
Moteur	30W
Chargeur	Entrée : AC 100V - 240V
	Sortie : DC 8V/500mA
Batterie	6V4A
Température ambiante de fonctionnement	0 - 40°C

II.Liste des pièces.

1.1x Corps 	2.1x Poignée 	3.2x Roue avant 	4.2x Roue arrière 
5.4x Couvercle de roue 	6.1x Pare-chocs 	7.1x Moteur 	8.1x Entretoise 
9.1x Manette en forme de J 	10.1x Essieu 	11.5x Goupille fendue (une de rechange) 	12.7x Rondelle (une de rechange) 
13.1x Chargeur 			

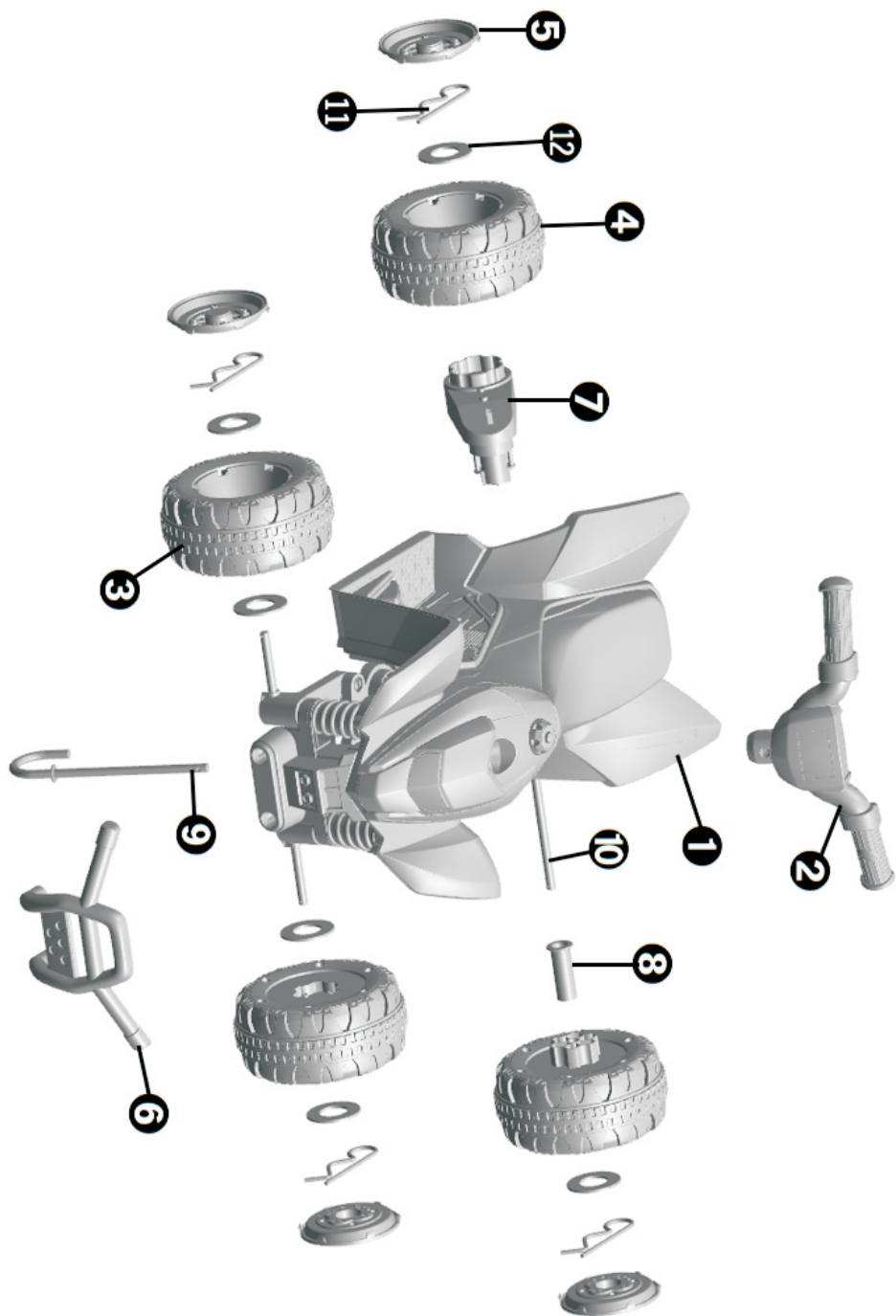

III. Instructions d'assemblage.

< 1 >

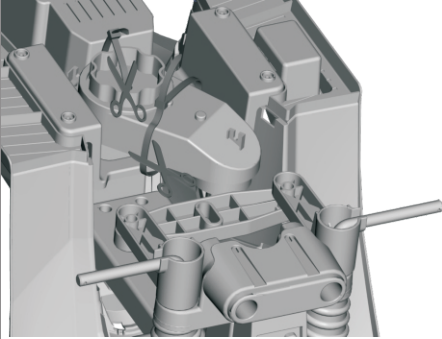

< 2 >

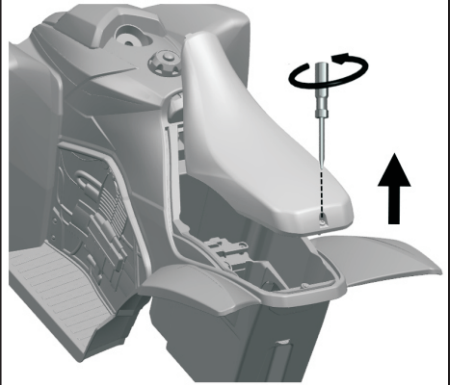

< 3 >

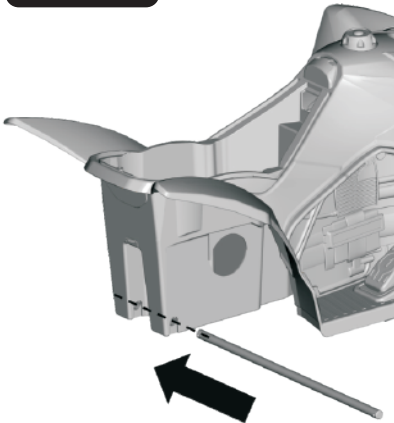

< 4 >

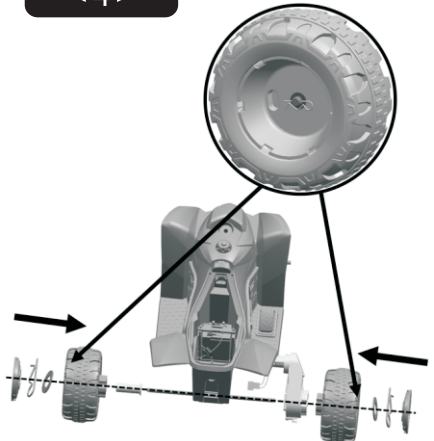

< 5 >

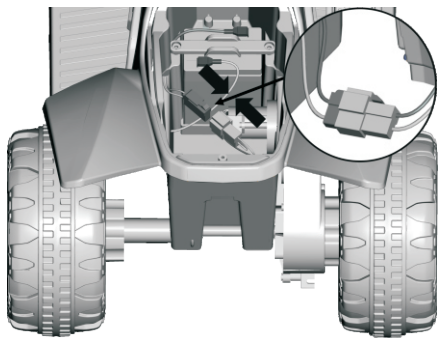

< 6 >

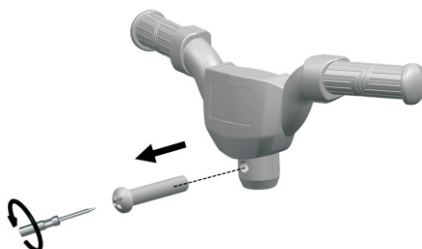

< 7 >

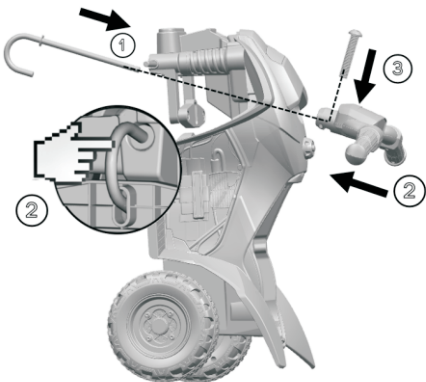

< 8 >

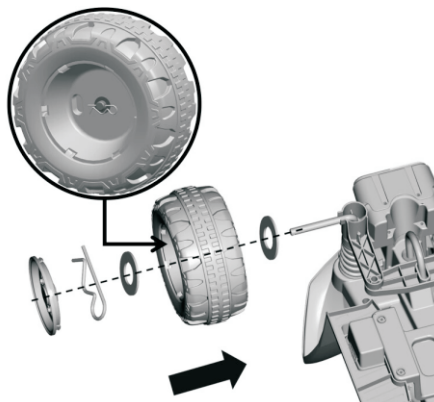

< 9 >

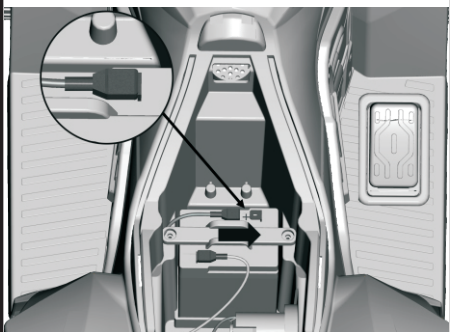

< 10 >

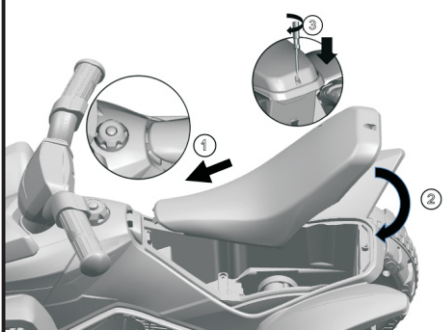

< 11 >

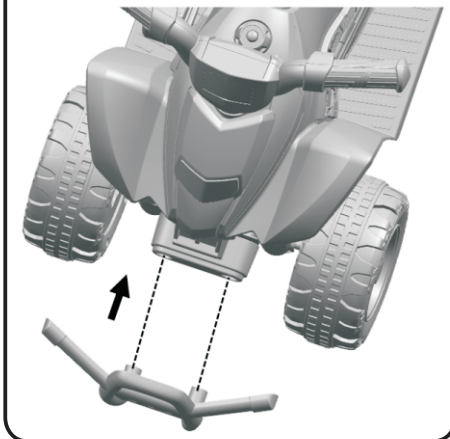

IV. Fonction et Mode d'emploi.

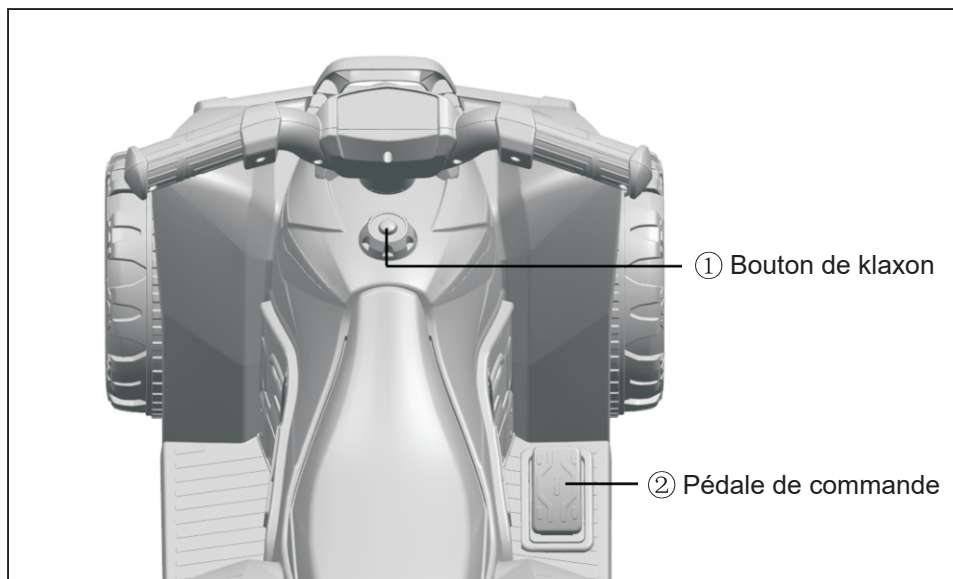

V. Guide d'utilisation de la batterie et du chargeur

1. La prise de charge se trouve à l'arrière.
2. Utilisez uniquement la batterie et le chargeur fournis ou recommandés.
3. Ne jouez pas avec le chargeur et la batterie.
4. Les batteries doivent être chargées uniquement par des adultes.
5. La batterie doit être entièrement chargée avant la première utilisation.
Chargez pendant 9 à 10 heures - ne dépassez pas 15 heures.
6. Lors de la charge, il est normal que le chargeur et la batterie soient chauds.

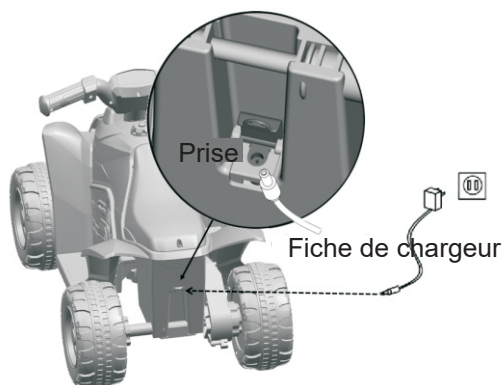

VI. AVERTISSEMENT

1. Avertissement de la batterie:

- 1) Lorsque vous stockez la voiture pendant une longue période, chargez complètement la batterie, puis éteignez l'alimentation. La batterie doit être rechargée une fois tous les deux mois - minimisant ainsi le risque de raccourcir sa durée de vie.
- 2) Lors de l'installation de la batterie, les pôles positif et négatif doivent être correctement connectés. Un court-circuit des pôles positif et négatif pourrait endommager le produit.

2. Avertissement du produit

- 1) Les pièces pré-assemblées peuvent être coupantes - l'assemblage du produit doit être effectué par un adulte. Gardez les pièces hors de la portée des petits enfants.
- 2) Pour éviter tout risque d'étouffement, gardez les sacs en plastique hors de la portée des enfants. Jetez immédiatement tous les sacs.
- 3) Lorsque les enfants utilisent ce produit, une surveillance d'adulte est nécessaire.
- 4) Cette voiture doit être utilisée sur un sol plat et régulier. Ne conduisez pas sur les routes publiques, les pentes raides ou près des piscines.
- 5) Portez des chaussures lors de l'utilisation de ce produit. Prenez des mesures de protection, telles que l'attache de la ceinture de sécurité et le port d'un casque, de gants, de genouillères, etc.
- 6) Vérifiez régulièrement l'état de la batterie, du chargeur, du câble, de la fiche, du boîtier et des autres pièces. Si des dommages sont constatés, ne pas utiliser le produit avant qu'il ait été réparé.
- 7) Ce produit peut accueillir un enfant à la fois. La charge maximale est de 25 kg - ne dépassez pas cette limite.
- 8) Gardez ce produit éloigné des flammes nues.
- 9) Conservez ce manuel pour référence future.



AVERTISSEMENT

- Surveillance d'un adulte requise - réduction du risque de blessure.
- Ne pas utiliser sur les routes, à proximité de véhicules à moteur, de pentes, de piscines ou de zones où il y a de l'eau.
- Portez des chaussures lors de l'utilisation de cette voiture.
- Ne peut être utilisé que par un enfant à la fois.
- Avant l'assemblage de ce produit, tenez-le hors de la portée des enfants. Il peut y avoir de petites et pointues pièces, ce qui peut être dangereux.
- Ce produit doit être assemblé par un adulte.



AVERTISSEMENT

Ne pas mélanger des piles alcalines, standard (carbone-zinc) ou rechargeables (nickel-cadmium).



AVERTISSEMENT

Un équipement de protection doit être porté. Ne pas circuler dans la circulation routière.

US

If you have any questions, please contact our customer care center.
Our contact details are below:



001-877-644-9366



customerservice@aosom.com

Imported by Aosom LLC
27150 SW Kinsman Rd Wilsonville, OR 97070 USA
MADE IN CHINA

CA

If you have any questions, please contact our customer care center.
Our contact details are below:

Si vous avez la moindre question, veuillez contacter notre centre d'assistance à la clientèle.
Nos coordonnées sont les suivantes:



416-792-6088



customerservice@aosom.ca

Imported by Aosom Canada Inc.
7270 Woodbine Avenue, Unit 307, Markham, Ontario Canada
L3R 4B9
MADE IN CHINA

Importé par Aosom Canada Inc.
7270 Woodbine Avenue, unité 307, Markham, Ontario Canada
L3R 4B9
FABRIQUÉ EN CHINE