

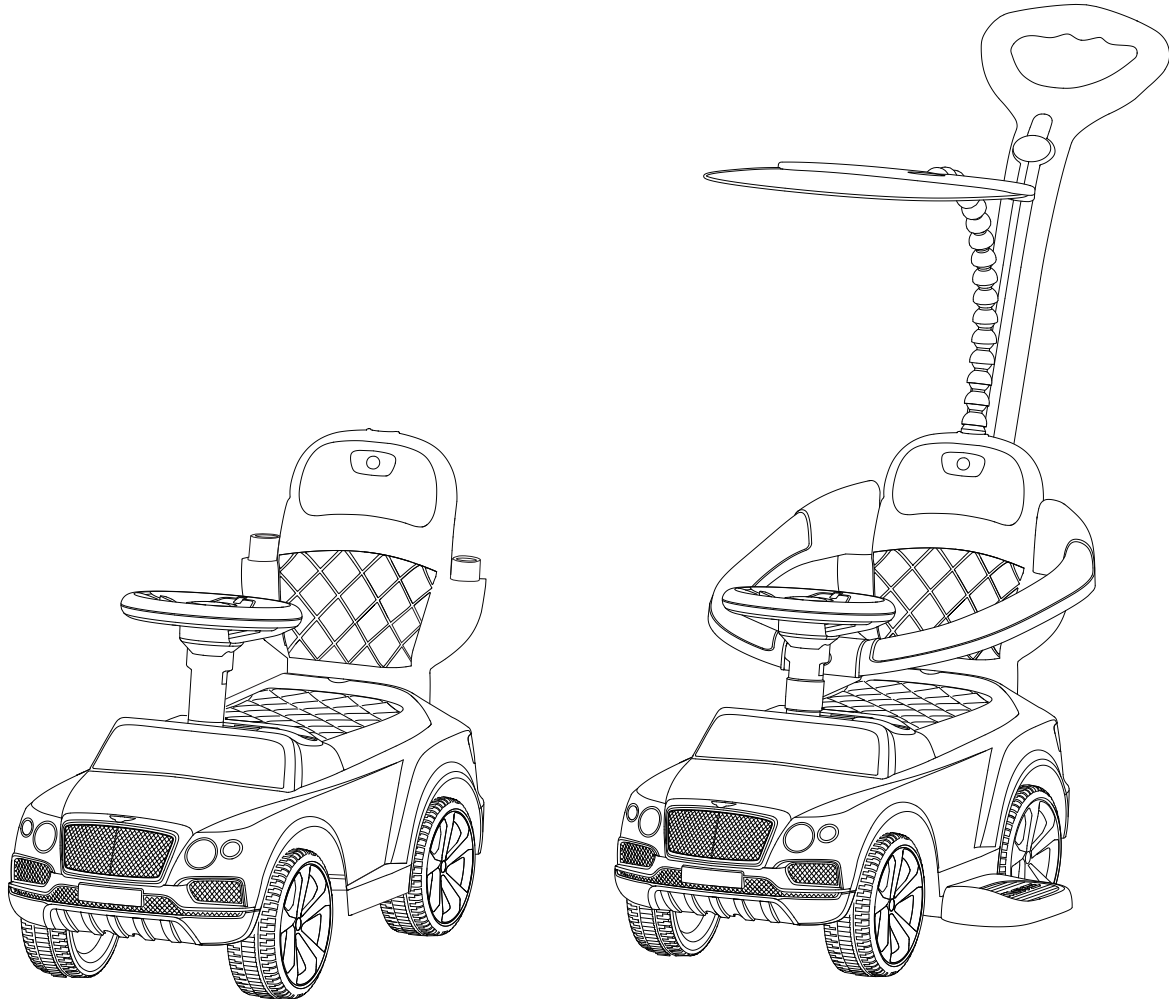

IN240200132V01\_US\_CA

**370-317V00**



## **ASSEMBLY INSTRUCTION INSTRUCTIONS D'ASSEMBLAGE**

EN: **WARNING:** Suitable for children of 12-36 months; Max weight: 25 kg.

FR: **ATTENTION:** Convient aux enfants de 12-36 mois; Poids maximum : 25 kg.

EN: **IMPORTANT, RETAIN FOR FUTURE REFERENCE: READ CAREFULLY.**  
FR: **IMPORTANT: A LIRE ATTENTIVEMENT ET A CONSERVER POUR VOUS Y  
REFRERER ULTERIEUREMENT**

## PART LIST

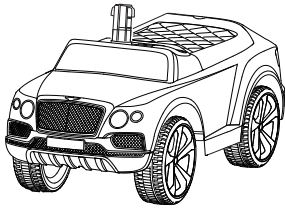

Car body

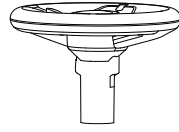

Steering Wheel

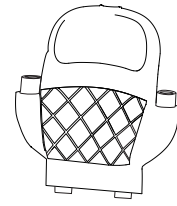

Seat back

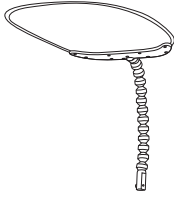

Canopy

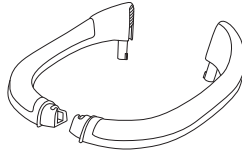

Armrest Guardrail

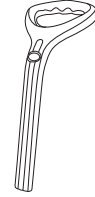

Push handle

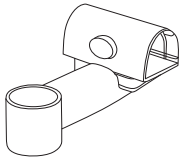

Safety Rail Buckle

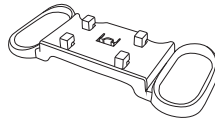

Footrest



Cup Holder



J

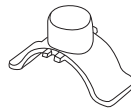

K

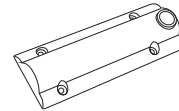

L



M

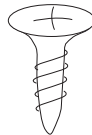

N

## ADULT ASSEMBLY INSTRUCTION

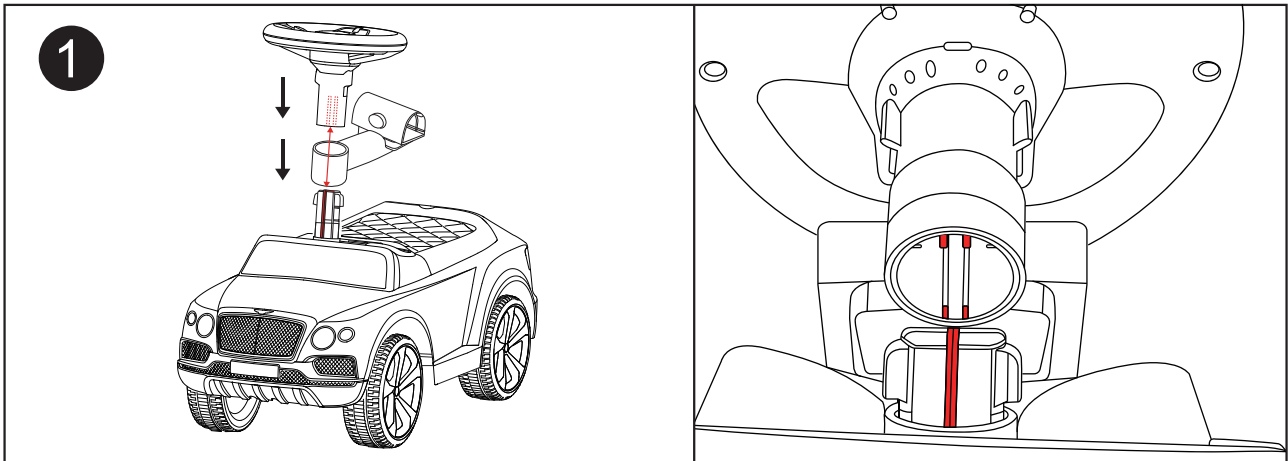

Fit the armrest assembly, align the steering shaft catch with the steering wheel slot and snap in (as shown).

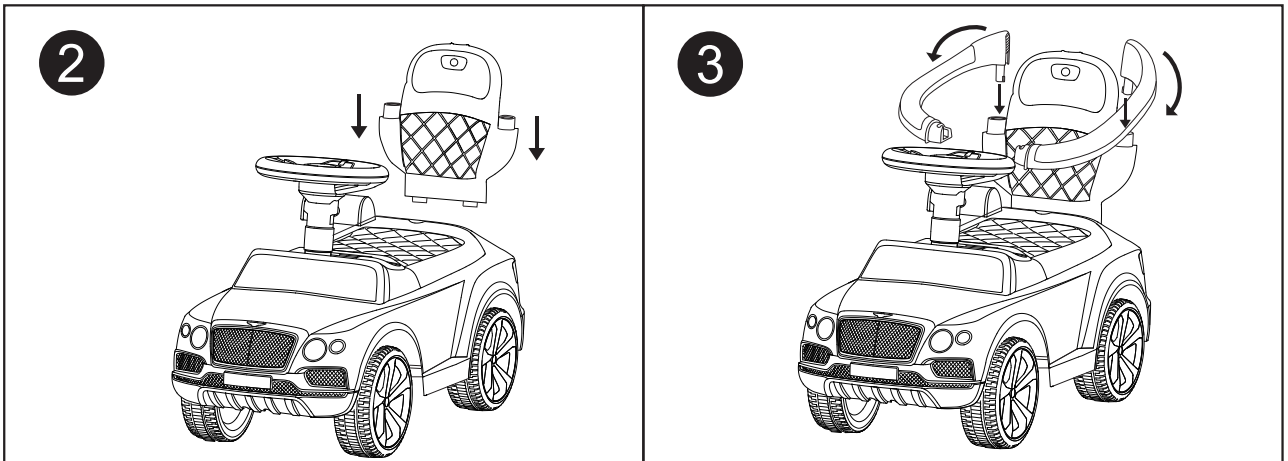

Insert Seat back as shown in the figure.

Locate the knob at the rear end and twist to secure the Armrest Guardrail as shown in the figure.

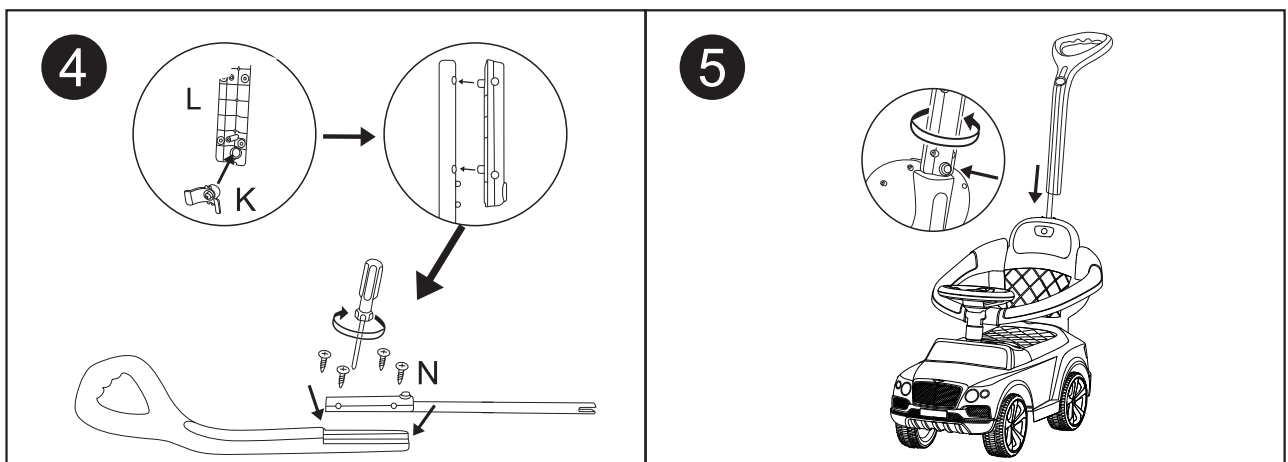

Use a Philip Screwdriver to screw the part L and assemble the push handle as shown in the figure.

Insert the Push handle as show in the figure.

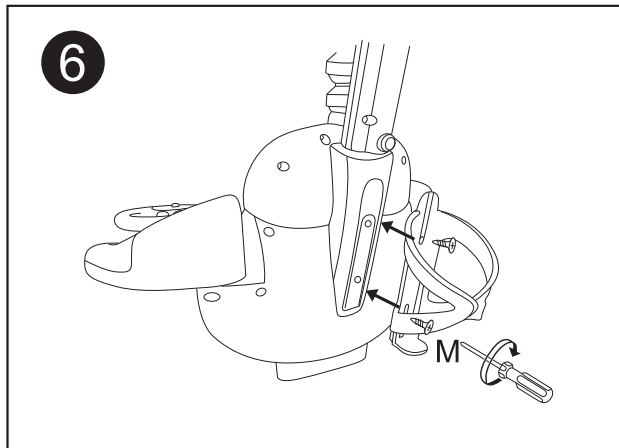

Secure the cup holder on the seat back as shown in the figure.

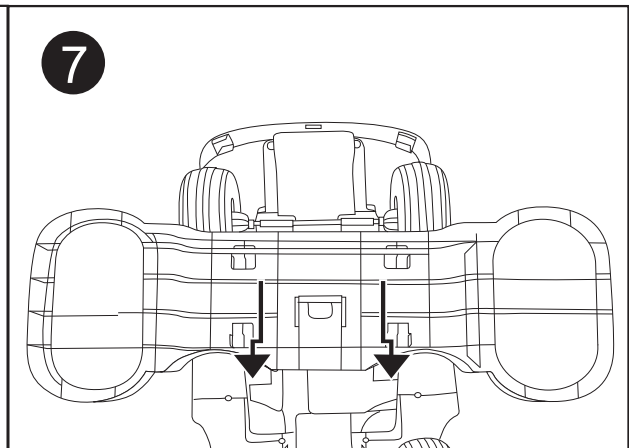

Assembly the footrest according to the arrow direction as shown in the figure.

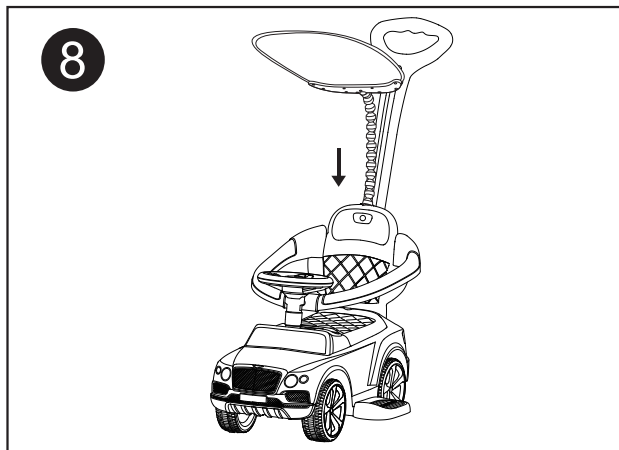

Assembly the canopy with one step as shown in the figure.

## Foot to Floor

This Bentayga 2 in 1 Activity Push on Car gives your little one so much to explore. After removing all the spare parts as shown above, it will perfectly transfers to a ride on.



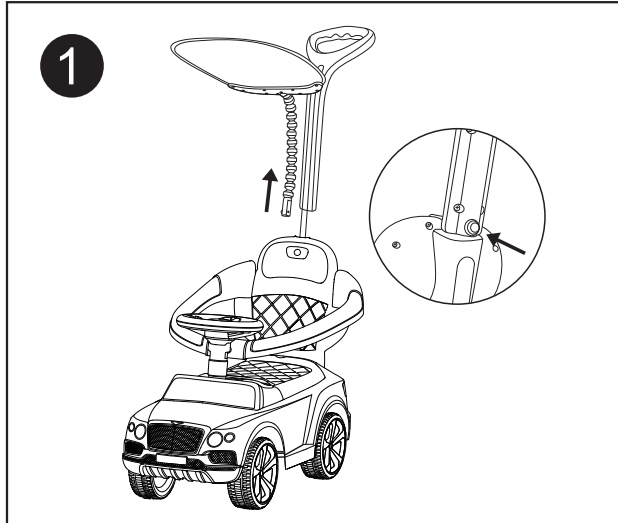

Press button to remove the canopy.

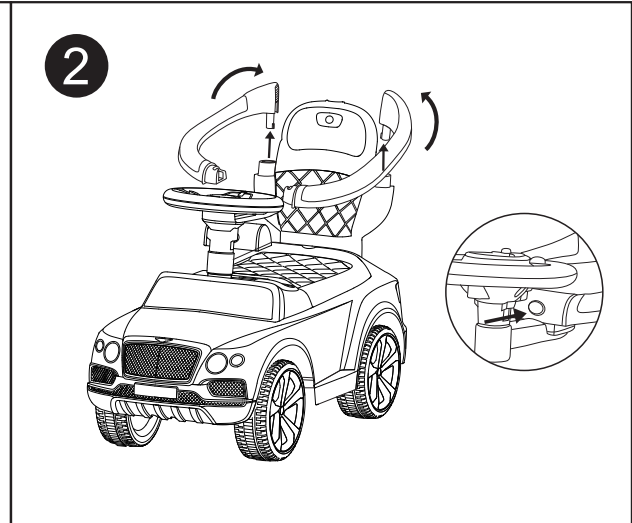

Press button to unlock safety rail buckle, and remove the armrest,

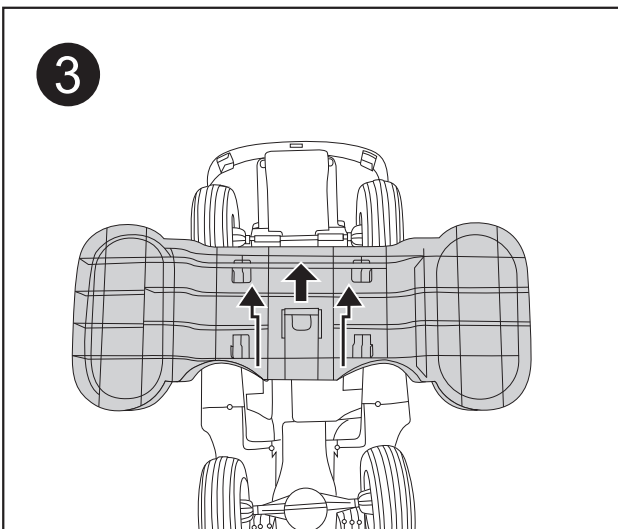

Pull the footrest in the direction of the arrow as shown to remove

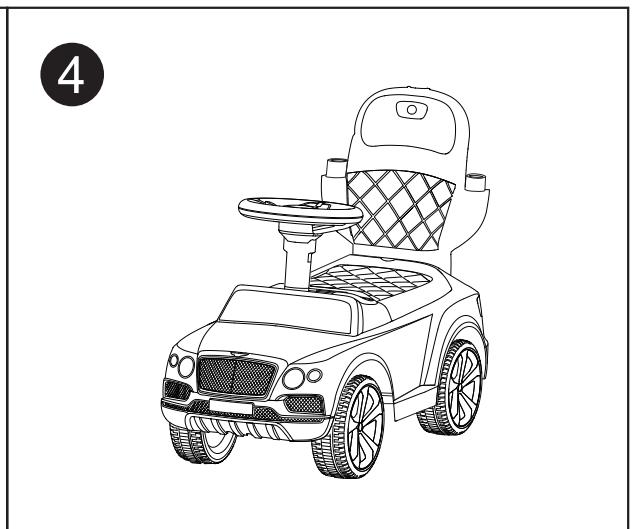

Completing the transaction to foot to floor.

## DIAGRAM OF STEERING WHEEL MUSIC BOX

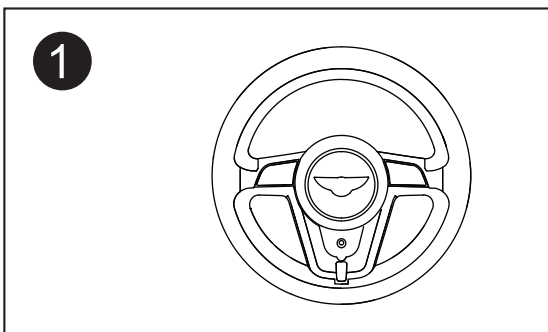

The Battery Cover is located on the steering wheel.

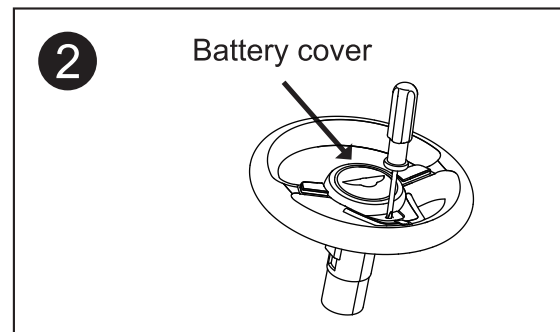

Use a Philip Screwdriver to unscrew the battery cover.

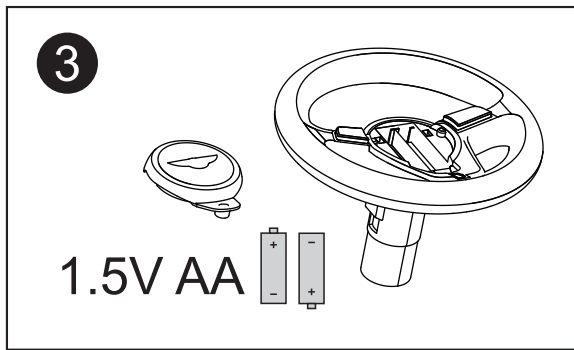

Insert Two AA batteries to place them according to signs shown (+,-)

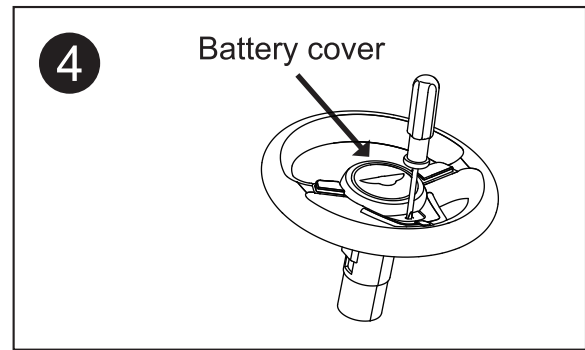

Use a Philip Screwdriver to screw the battery cover.

## DIAGRAM OF CAR BODY MUSIC BOX

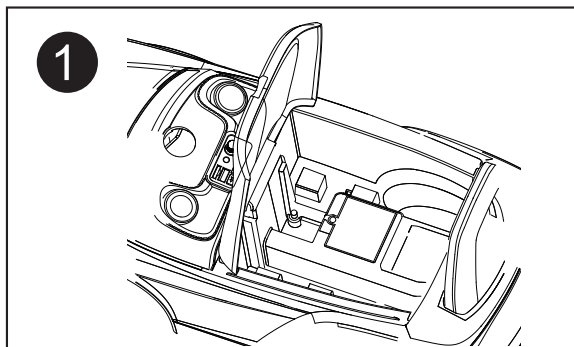

The Battery Cover is located under the seat.

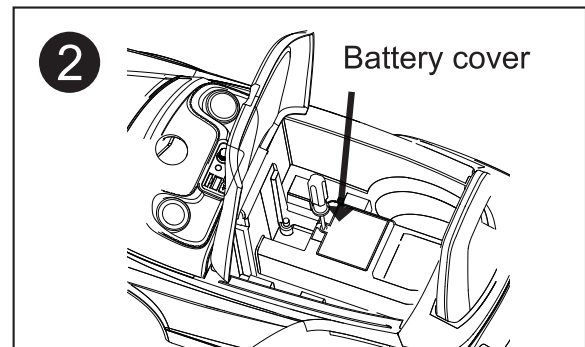

Use a Philip Screwdriver to unscrew the battery cover.

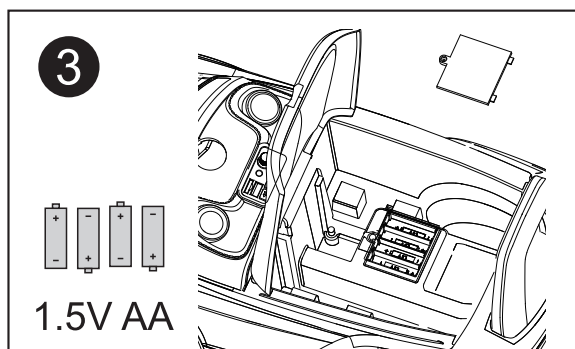

Insert Two AA batteries to place them according to signs shown (+,-)

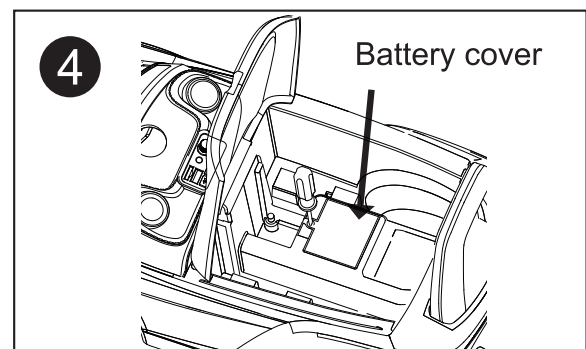

Use a Philip Screwdriver to screw the battery cover.

## WARNING

1. This product is suitable for children for 12-36 months;
2. This product may have potential sharp edges, tips or small parts before assembly and must be assembled by adults;
3. Children should ride this on flat and smooth surface, and should keep away from traffic road; Strictly prohibited in nearby motor vehicles, streets, steps, slopes, hills, roads, alleys, swimming pools or other places with water;
4. This product shall be used under the custody of adults and shall wear shoes;
5. This product is only limited to one-person ride, with a maximum carrying capacity of 25 kg;
6. Adult assembly and installation of all parts are required.
7. Do not let Children playing alone with this product prevent from danger of Falling.
8. Not suitable for children under 1 years. Small parts. Choking hazard.
9. The toy should be used with caution since skill is required to avoid falls or collisions causing injury to the user or third parties.

## BATTERY INSTRUCTIONS

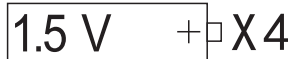
1. Batteries must be handled by adults only.
2. Keep all nuts and bolts out of reach of children as they may cause potential choking hazard.
3. Hand in the non-working batteries to an appropriate waste disposal center.
4. Do not mix old and new batteries
5. Use AA Size Batteries only.
6. Do not attempt to recharge non rechargeable batteries. 
7. Rechargeable batteries are only to be charged under adult supervision. 
8. Insert batteries to place them according to signs shown (+,-).
9. Always remove exhausted batteries.



### Warning

Keep small parts and plastic bag out of reach of children.







### Warning

Hand in the non-working batteries to an appropriate waste disposal center.

## MAINTAINENCE

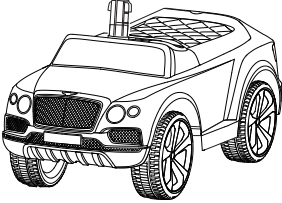
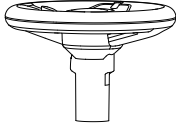
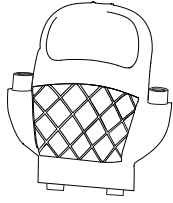
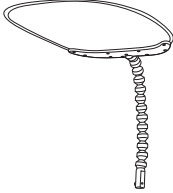
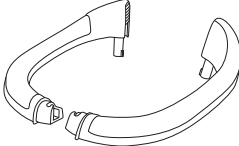
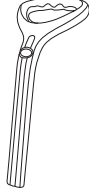
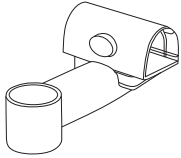
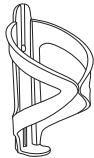
1. Wipe clean with dry cloth on surface only.
2. Avoid direct Sun exposure.
3. Occasionally check to see that the nuts and bolts on all parts are secure and tight.
4. Always remove batteries when the unit is not going to be used for an extended period of time.

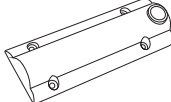
## LISTE DES PIÈCES

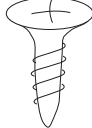
		
Carrosserie	Volant	Dossier
		
Auvent	Garde-corps de l'accoudoir	Poignée de poussée
		
Boucle de sécurité pour rail	Repose-pieds	Porte-gobelet
		
J	K	L
		
M	N	

## INSTRUCTIONS D'ASSEMBLAGE POUR ADULTES

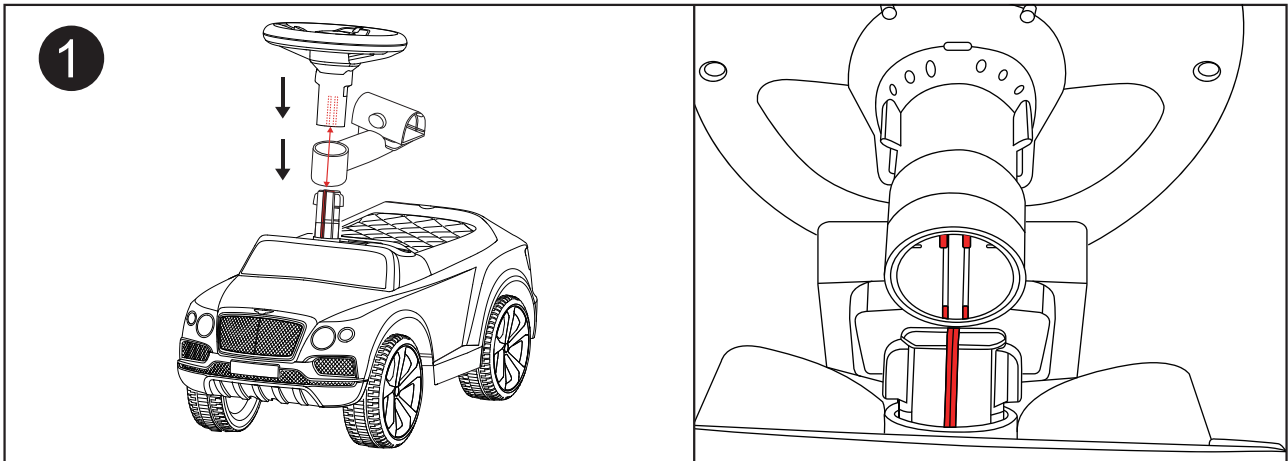

Fixez l'accoudoir, alignez le loquet de l'arbre de direction avec la fente du volant et enclenchez-le (comme illustré).

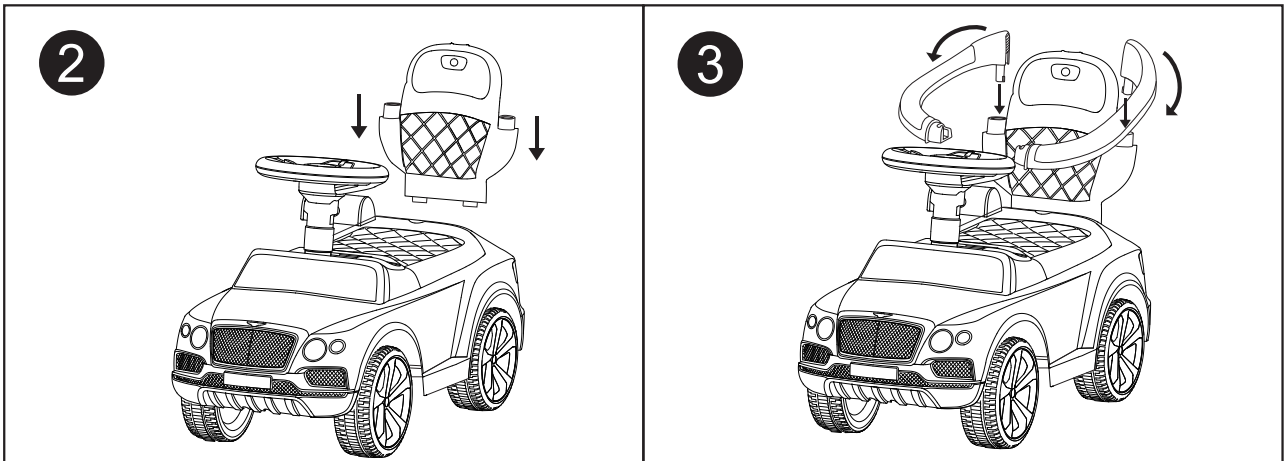

Insérez le dossier du siège comme indiqué sur la figure.

Localisez le bouton à l'arrière et tournez-le pour fixer le garde-corps de l'accoudoir comme indiqué sur la figure.

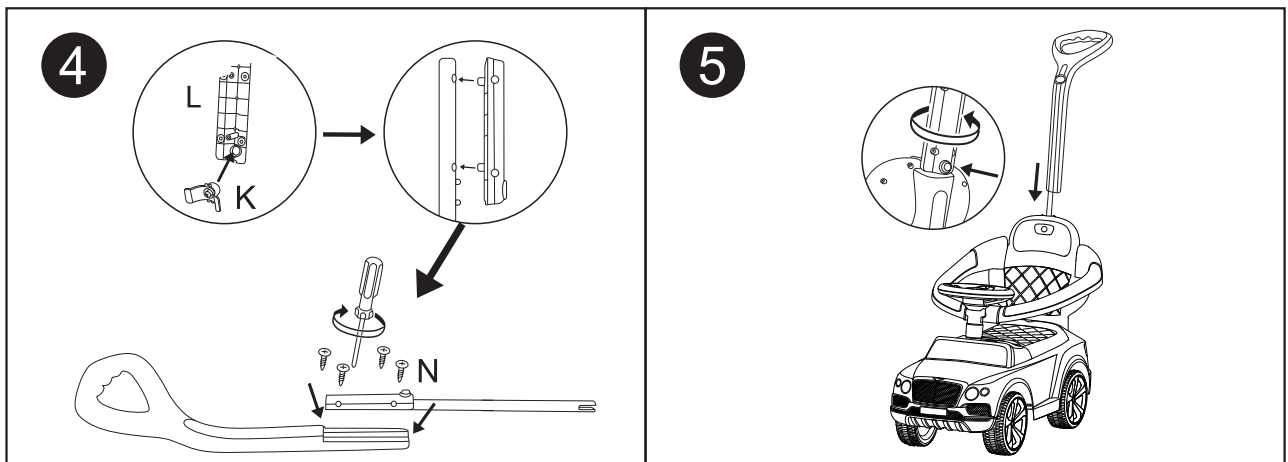

Vissez la pièce L avec un tournevis cruciforme et assemblez le poignée de poussée comme indiqué sur la figure.

Insérez la poignée de poussée comme indiqué sur la figure.

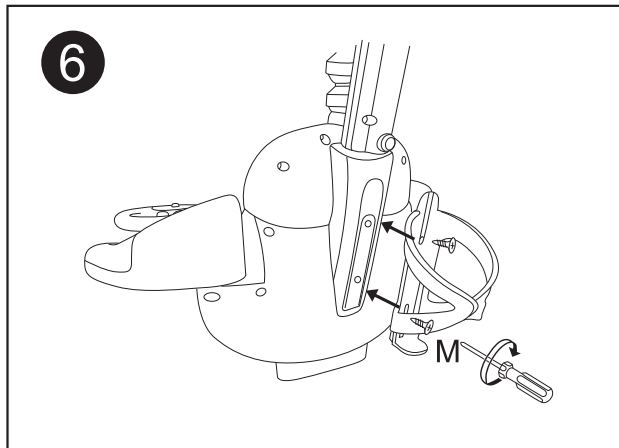

Fixez le porte-gobelet sur le dossier du siège comme indiqué sur la figure.

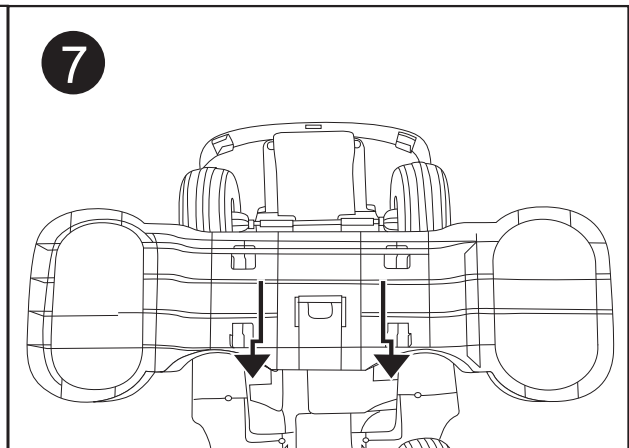

Assemblez le repose-pied selon la direction de la flèche comme indiqué dans la figure

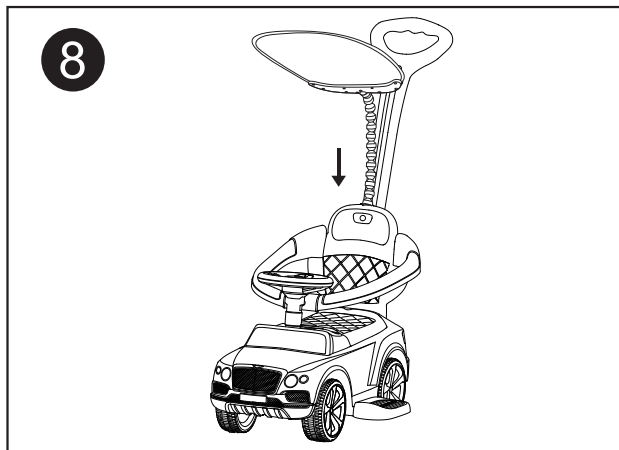

Assemblez l'auvent en une seule étape, comme indiqué sur la figure.

## Voiture Pousse-pied

Cette voiture à pousser évolutive 2 en 1 Bentayga offre à votre tout-petit tant de possibilités à explorer. Après avoir retiré toutes les pièces de rechange comme indiqué ci-dessus, il se transforme parfaitement en voiture pousse-pied.

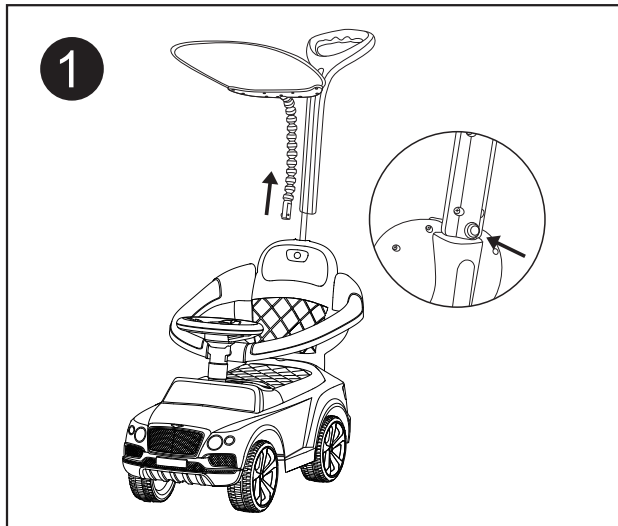

1 Appuyez sur le bouton pour retirer l'auvent.

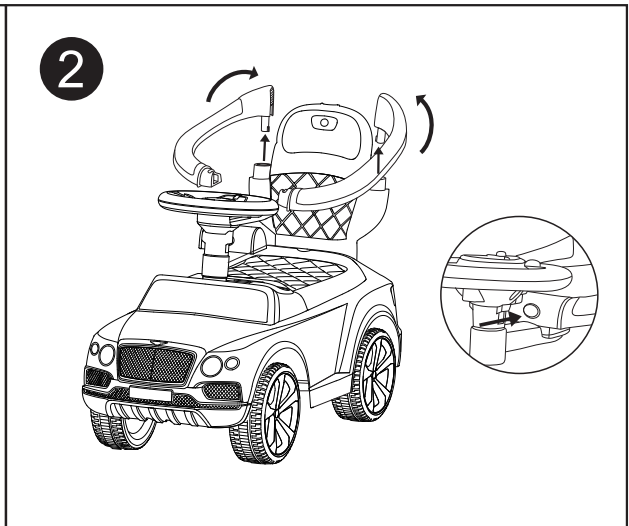

2 Appuyez sur le bouton pour déverrouiller la boucle de sécurité pour rail et retirez le garde-corps de l'accoudoir

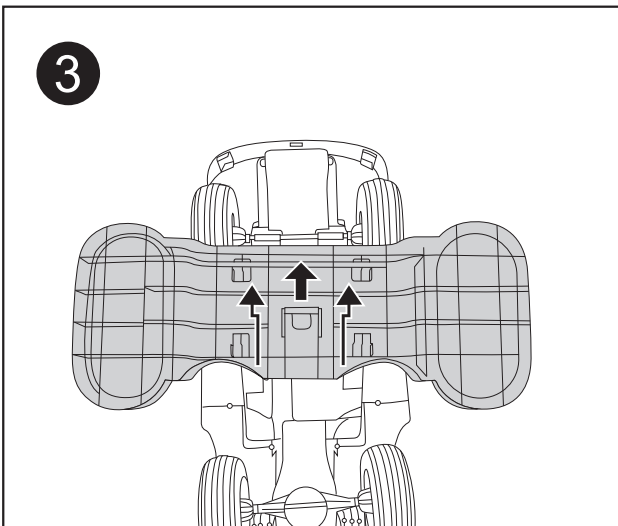

3 Tirez le repose-pied dans la direction de la flèche comme indiqué

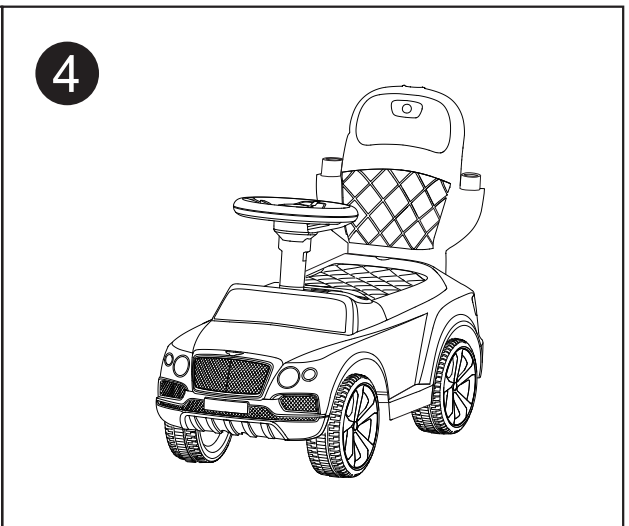

4 Achevez la transformation en voiture pousse-pied

## SCHÉMA DE LA BOÎTE À MUSIQUE DU VOLANT

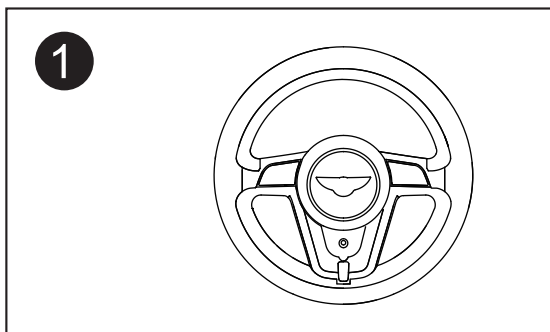

1 Le couvercle de la pile est situé sur le volant.

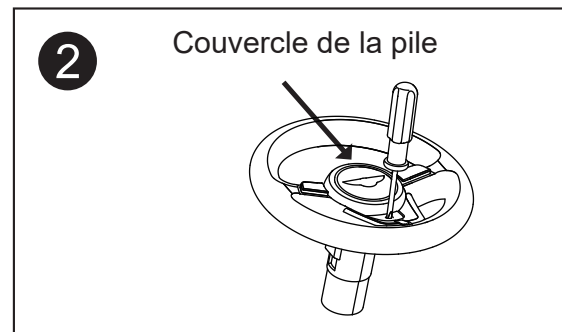

2 Dévissez le couvercle de la pile avec un tournevis cruciforme



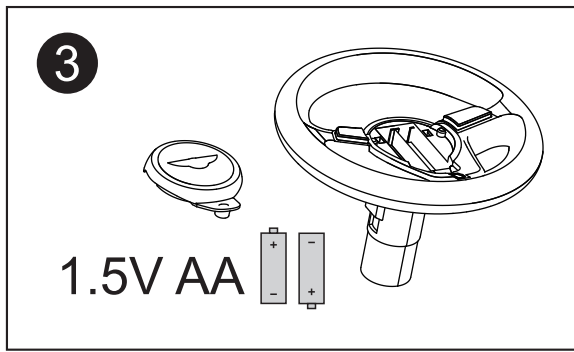

Insérez deux piles AA pour les placer selon les signes indiqués (+,-)

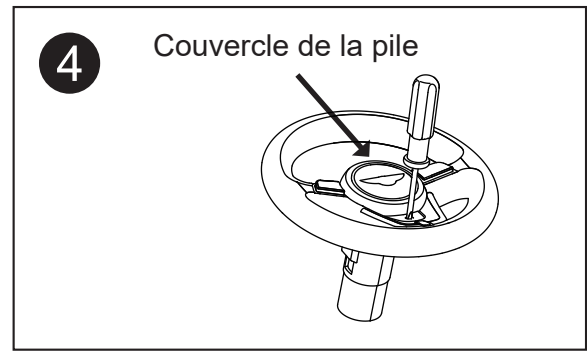

Dévissez le couvercle de la pile avec un tournevis cruciforme

## SCHÉMA DE LA BOÎTE À MUSIQUE DE CARROSSERIE

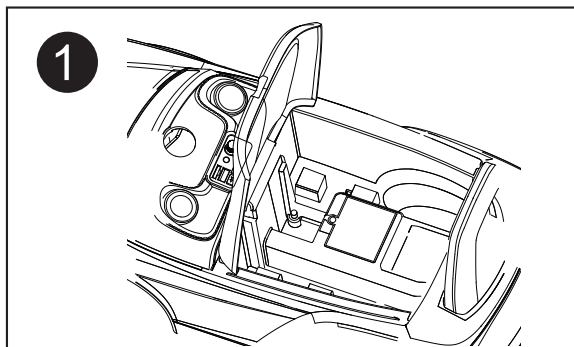

Le couvercle de la pile est situé sous le siège.

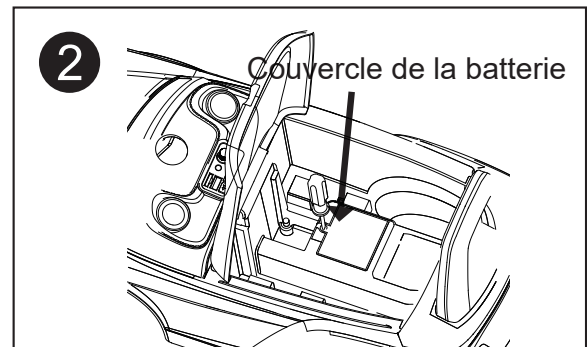

Dévissez le couvercle de la pile avec un tournevis cruciforme.

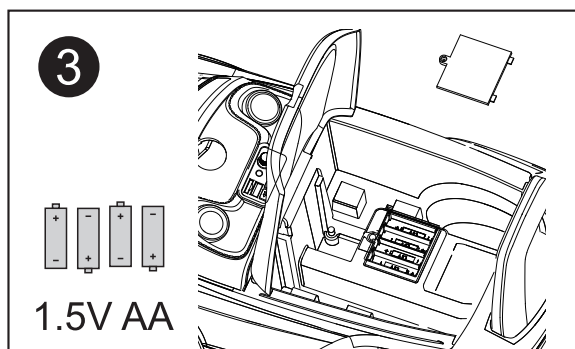

Insérez deux piles AA pour les placer selon les signes indiqués (+,-)

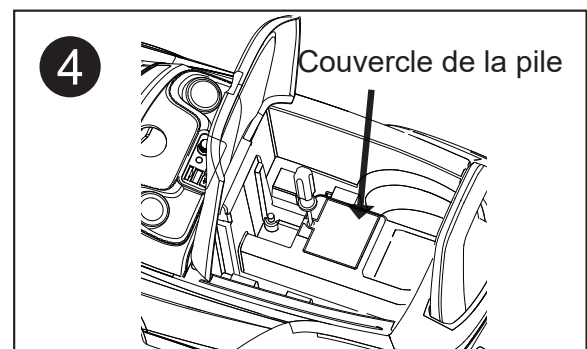

Dévissez le couvercle de la pile avec un tournevis cruciforme.

## Avertissement

1. Ce produit convient aux enfants de 12-36 mois ;
2. Ce produit peut comporter des arêtes vives, des pointes ou de petites pièces potentielles avant l'assemblage et doit être assemblé par des adultes ;
3. Les enfants doivent utiliser ce produit sur une surface plate et lisse, et doivent s'éloigner des routes de circulation ; Il est strictement interdit de l'utiliser à proximité de véhicules motorisés, de rues, d'escaliers, de pentes, de collines, de routes, d'allées, de piscines ou d'autres endroits avec de l'eau ;
4. Ce produit doit être utilisé sous la surveillance d'adultes et doit être porté avec des chaussures ;
5. Ce produit est limité à une seule personne, avec une capacité de charge maximale de 25 kg ;
6. L'assemblage et l'installation de toutes les pièces doivent être effectués par un adulte.
7. Ne laissez pas les enfants jouer seuls avec ce produit pour éviter les chutes.
8. Ne convient pas aux enfants de moins de 1 ans. Petites pièces. Risque d'étouffement.
9. Le jouet doit être utilisé avec prudence car des compétences sont nécessaires pour éviter les chutes ou les collisions pouvant causer des blessures à l'utilisateur ou à des tiers.

## INSTRUCTIONS SUR LA PILE

1. Les piles ne doivent être manipulées que par des adultes.
2. Gardez tous les écrous et boulons hors de portée des enfants car ils peuvent entraîner un risque potentiel de blocage.
3. Remettez les piles usagées à un centre d'élimination des déchets approprié
4. Ne pas mélanger les piles neuves et usagées
5. N'utilisez que des piles AA.
6. N'essayez pas de recharger des piles non rechargeables.
7. Les batteries rechargeables ne doivent être chargées que sous la supervision d'un adulte.
8. Insérez les piles pour les placer selon les signes indiqués (+,-).
9. Retirez toujours les piles épuisées.

1.5 V + □ X 2

1.5 V + □ X 4



### Avertissement

Conservez les petites pièces et le plastique sac hors de portée de enfants.



### Avertissement

Remettez les piles usagées à un centre d'élimination des déchets approprié.

## ENTRETIEN

1. Essuyez la surface avec un chiffon sec.
2. Évitez l'exposition directe au soleil.
3. Vérifiez de temps en temps que les écrous et les boulons de toutes les pièces sont bien fixés et serrés.
4. Retirez toujours les piles lorsque l'appareil n'est pas utilisé pendant une période prolongée.

## US

If you have any questions, please contact our customer care center.  
Our contact details are below:



001-877-644-9366



customerservice@aosom.com

Imported by Aosom LLC  
27150 SW Kinsman Rd Wilsonville, OR 97070 USA  
MADE IN CHINA

## CA

If you have any questions, please contact our customer care center.  
Our contact details are below:

Si vous avez la moindre question, veuillez contacter notre centre d'assistance à la clientèle.  
Nos coordonnées sont les suivantes:



416-792-6088



customerservice@aosom.ca

Imported by Aosom Canada Inc.  
7270 Woodbine Avenue, Unit 307, Markham, Ontario Canada  
L3R 4B9  
MADE IN CHINA

Importé par Aosom Canada Inc.  
7270 Woodbine Avenue, unité 307, Markham, Ontario Canada  
L3R 4B9  
FABRIQUÉ EN CHINE