

# Flat weight bench

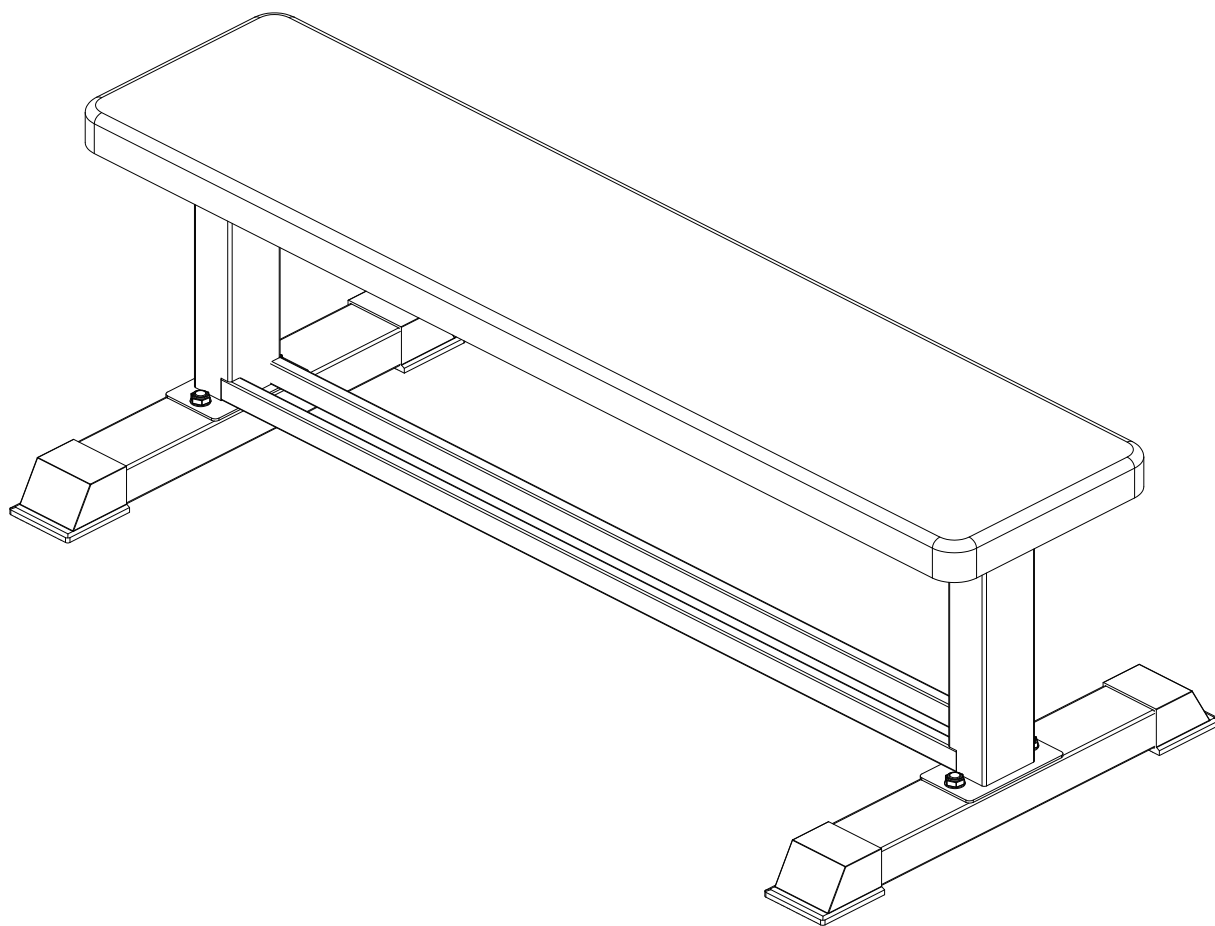

Max weight: 300 kg

IMPORTANT, RETAIN FOR FUTURE REFERENCE: READ CAREFULLY

**ASSEMBLY INSTRUCTIONS**

## SAFETY INFORMATION

### IMPORTANT – Please read fully before assembly or use.

This exercise equipment is built for optimum safety. However, certain precautions apply whenever you operate a piece of exercise equipment. Be sure to read the entire manual before you assemble, operate, or use this equipment, note the following safety precautions.

#### Warning for assembly

- Ensure you have all the parts and tools listed.
- Remove all fittings from the plastic bags and separate them into their groups.
- Keep children and animals away from the work areas, small parts can cause a choking hazard if swallowed.
- Ensure you have enough space to layout the parts before starting.

The assembly of this equipment is best carried out by 2 persons.

- Assemble the item as close to its final position (in the same room) as possible.
- The free-standing equipment shall be installed on a stable and level base.
- Dispose of all packaging carefully and responsibly.

#### Warning for using

- This exercise equipment is made for training in private environment. Only use the equipment for its intended use.
- **DO NOT** make any changes to the equipment which can affect the security of the product.
- **Warning! Pregnant or physically injured persons should never use the weight station without prior consultation with a doctor you trust.**
- Be aware of your body's signals. Incorrect or excessive exercise can damage your health.
- **STOP** exercising if you experience any pain, tightness in your chest, irregular heartbeat, extreme shortness of breath, lightheadedness, dizziness, or nausea. If you do experience any of these conditions you should **CONSULT YOUR DOCTOR IMMEDIATELY** before continuing with your exercise program.
- Always adapt your training style to your personal fitness level and health.
- Before every training session, ensure you check the equipment for operation and safety.
- Before using, ensure the item is installed correctly and that all safety devices are functional! Damages or alterations to the product resulting from modification, will invalidate your warranty. For problems resulting from the modification or other restrictions, the seller is not responsible.

- Any damage must be reported to the seller immediately after delivery, and before use or installation. Later complaints will not be considered.
- Use only suitable tools for assembly.
- The installation must ONLY be carried out by adults. Children should not be present in the immediate environment where the assembly is taking place.
- Make sure all connections are securely mounted before releasing the product for use.
- Check all connections at regular intervals for damage, loose elements and other factors that can lead to a loss of sufficient security.
- Do not leave children unattended on the weight bench! It is not a toy! Instruct them not to play with or climb on the appliance.
- In case of a fault during day-to-day use, or during maintenance, lock the equipment to prevent any risk of injury.
- Children or persons with limited physical or mental abilities, or those not familiar with this device, should not be allowed to use this weight bench!
- Please keep in mind that this manual and the safety can only draw your attention to eventual hazard. Logical conclusions and care should always be practiced when handling this device.
- Before using the equipment to exercise, always warm up with stretching exercises.
- Before using the equipment, check the nuts and bolts are securely tightened.
- Use the equipment on a solid, flat surface with a protective cover for your floor or carpet.
- The safety level of the equipment can only be maintained if it is regularly examined for damage and/or wear and tear. If you find any defective components whilst assembling or checking the equipment, or if you hear any unusual sounds, from the equipment during use, STOP! Do not use the equipment until the problem has been rectified.
- Wear suitable clothing whilst using the equipment. Avoid wearing loose clothing which may get caught in the equipment or that may restrict or prevent movement.
- Before starting any exercise or conditioning program you should consult with your personal physician to see if you require a complete physical exam. This is especially important if you are over the age of 35, have never exercised before, are pregnant, or suffer from any illness.

## **CLEANING AND MAINTENANCE**

1. Regularly examine the equipment to detect any damage to wear which may have occurred.

The safety level of the equipment can be maintained only if it is examined regularly for damage and wear and tear on ropes, pulleys, and connection points.

2. Lubricate moving parts with light oil periodically to prevent premature wear.

3. Inspect and tighten all parts before using the equipment. Replace defective components immediately and/or keep the equipment out of use until repair. Pay particular attention to components most susceptible to wear.

4. The equipment can be cleaned using a soft, damp cloth. Do not use solvents or abrasive cleaners.

## Parts List

Please check all accessories carefully

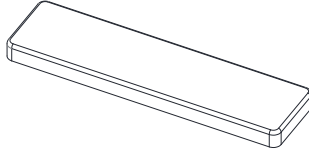
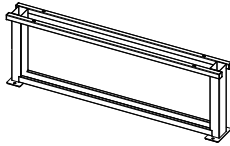
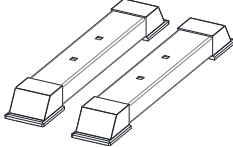
Sequence number	Name	Schematic	Quantity
A	Seat pad		1
B	Flat bench support		1
C	Foot tube		2

## Screw Package List

Sequence Number	Name	Specification	Units	Quantity
1	Carriage screw	M10*65	pcs	4
2	Inner hexagon screw	M6*37	pcs	4
3	Lock nut	M10	pcs	4
4	Washers	Ø10.5*Ø20*1.5	pcs	4
5	Open wrench	Opposite side 17	pcs	1
6	L-wrench	Opposite side 5mm	pcs	1

## Installation Steps

### Step 1:

- Remove all parts from the box, take out the plastic bag and place them on a clean and flat surface.
- Put the seat pad in place as shown in the picture.
- Take out the long horizontal tube surface of the flat bench support and place it on the seat pad.
- Make sure the four mounting holes on the bench support align with the fixing holes on the seat pad.
- Take out four M6\*37 hexagon screws and the L-wrench tool from the screw package.
- Use the L-wrench tool to tighten the screws.

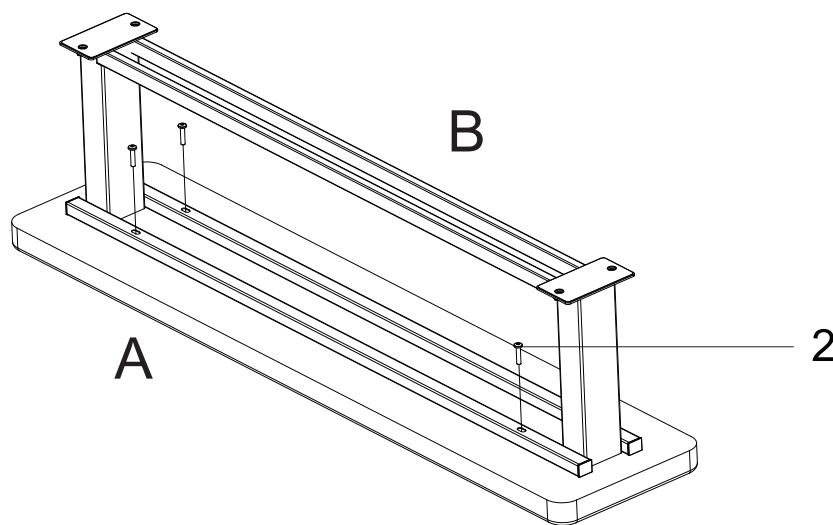

### Step 2:

- Take out the foot tube.
- Place the foot tube on the bottom plate of the flat bench support, following the picture.
- Align the two mounting holes.
- Take out four M10\*65 screws and the L-wrench from the screw package.
- Use the L-wrench to tighten the screws.

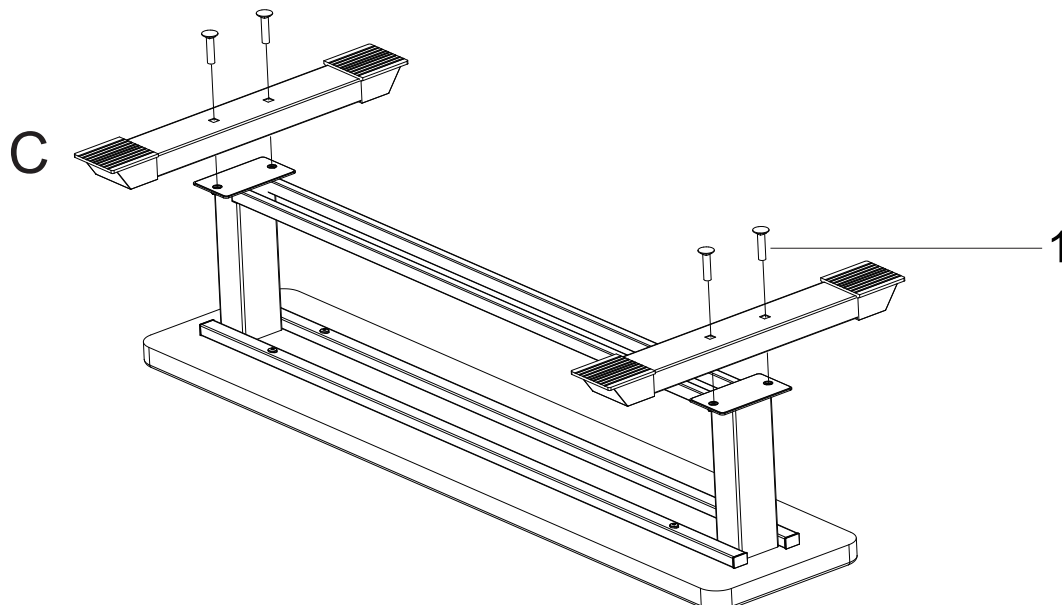

**Step 3:**

- Take out four M10 lock nuts and washers.
- Place the washers onto the nuts.
- Tighten the nuts with a wrench.

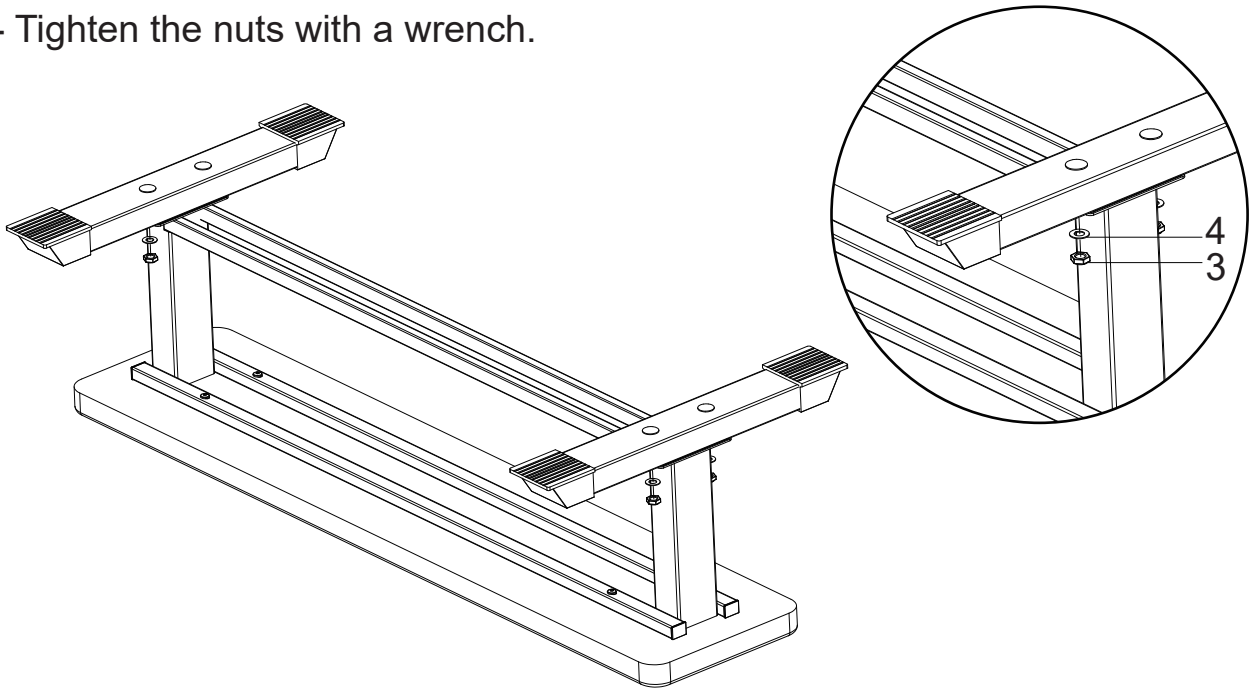
**Step 4:**

- Flip the installed flat bench over, placing it on a flat ground.
- It is now ready for use.

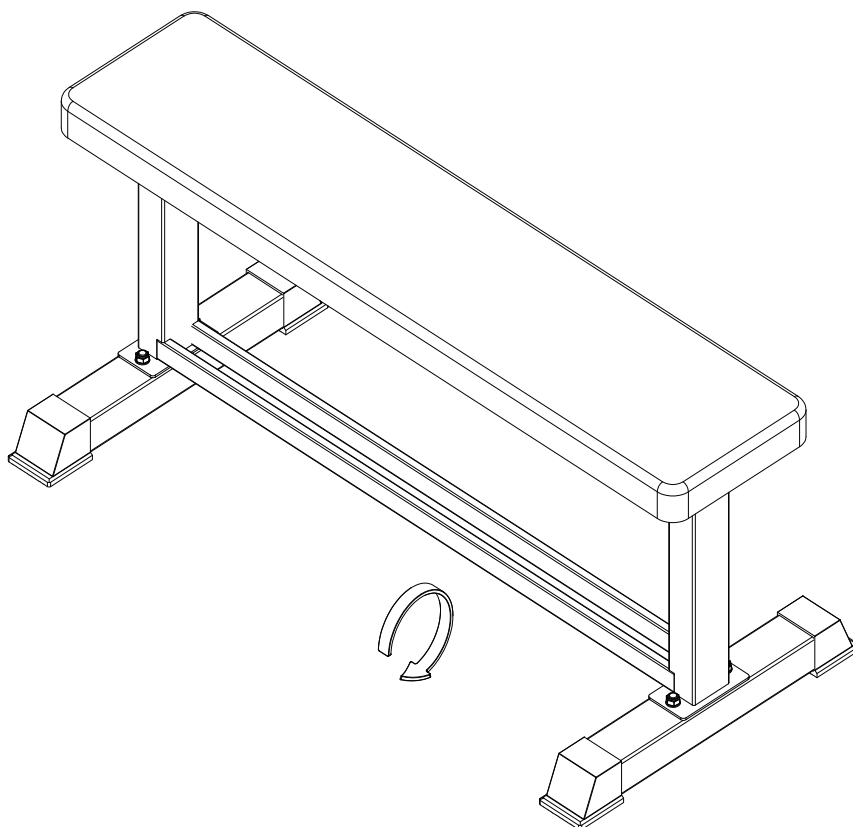

**UK**

If you have any questions, please contact our customer care center.

Our contact details are below:



0044-800-240-4004



enquiries@mhstar.co.uk

IMPORTER ADDRESS:  
MH STAR UK LTD  
Unit 27, Perivale Park,  
Horsenden lane South  
Perivale, UB6 7RH  
MADE IN CHINA

**ES**

Si tiene alguna pregunta, comuníquese con nuestro Centro de Atención al Cliente. Nuestros datos de contacto son los siguientes:



0034-931294512



atencioncliente@aosom.es

IMPORTADOR:  
SPANISH AOSOM, S.L.  
C/ ROC GROS, N° 15. 08550, ELS HOSTALETS DE  
BALENYÀ, SPAIN.  
B66295775  
WWW.AOSOM.ES  
ATENCIONCLIENTE@AOSOM.ES  
TEL: 931294512  
HECHO EN CHINA

**FR**

Si vous avez la moindre question, veuillez contacter notre centre d'assistance à la clientèle.

Nos coordonnées sont les suivantes:



0033-1-84166106



aosom@mhfrance.fr

Importé par:  
MH France  
2, rue Maurice Hartmann  
92130 Issy-les-Moulineaux  
France  
Fabriqué en Chine

**PT**

Se tiver alguma dúvida, por favor contacte o nosso Centro de Atendimento ao Cliente. Os nossos dados de contacto são os seguintes:



0034-931294512



info@aosom.pt.

IMPORTADOR:  
SPANISH AOSOM, S.L.  
C.ROC GROS N.15, 08550. ELS HOSTALETS DE BALENYÀ  
TEL: 931294512 (SEG-SEX DAS 7:30H ÀS 16:30H)  
INFO@AOSOM.PT  
WWW.AOSOM.PT

**DE**

Wenn Sie Fragen haben, wenden Sie sich bitte an unser Kundendienstzentrum.

Unsere Kontaktdaten stehen unten:



0049-(0)40-88307530



service@aosom.de

ADRESSE DES IMPORTEURE:  
MH Handel GmbH  
Wendenstraße 309  
D-20537 Hamburg  
Germany  
IN CHINA HERGESTELLT

**IT**

In caso di dubbio, si prega di contattare il nostro centro assistenza clienti. I nostri dettagli di contatto sono di seguito:



0039-0249471447



clienti@aosom.it

IMPORTATO DA:  
AOSOM Italy srl  
Centro Direzionale Milanofiori  
Strada 1 Palazzo F1  
20057 Assago (MI)  
P.I.: 08567220960  
FATTO IN CINA