

**EN\_IMPORTANT, RETAIN FOR FUTURE REFERENCE: READ CAREFULLY.**

**FR\_IMPORTANT: A LIRE ATTENTIVEMENT ET À CONSERVER POUR CONSULTATION ULTÉRIEURE.**

**ES\_IMPORTANTE, LEA Y GUARDE PARA FUTURAS REFERENCIAS.**

**PT\_IMPORTANTE, RETER PARA REFERÊNCIA FUTURA: LEIA ATENTAMENTE.**

**DE\_WICHTIG! SORGFÄLTIG LESEN UND FÜR SPÄTER NACHSCHLAGEN AUFBEWAHREN.**

**IT\_IMPORTANTE! CONSERVARE IL PRESENTE MANUALE PER FUTURO RIFERIMENTO E LEGGERLO ATTENTAMENTE.**

## IF HAVE THIS ACCESSORY

NOTE DIFFERENT MODELS

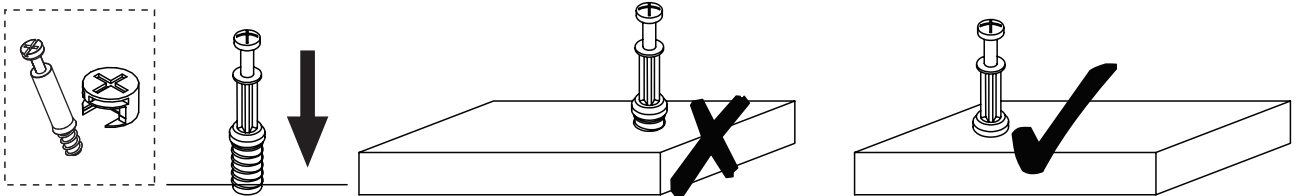

**EN\_QUICKFIT:** Tighten quickfit until shoulder is flush with panel. Do not overtighten or undertighten.

**FR\_RACCORD RAPIDE:** Faites serrer le raccord rapide jusqu'à ce que l'épaulement soit parfaitement encastré dans le panneau. Il ne faut ni trop serrer ni insuffisamment serrer.

**ES\_QUICKFIT:** Apriete quickfit hasta que el hombro se descargue con el panel. NO lo sobreapriete ni lo apriete poco.

**PT\_AJUSTE RÁPIDO:** Aperte o ajuste rápido até estar nivelada com o painel. Não apertar demasiado ou excessivamente.

**DE\_QUICKFIT:** Ziehen Sie den Quickfit fest, bis die Schulter mit der Platte bündig ist. Bitte nicht zu fest oder zu schwach anziehen.

**IT\_MONTAGGIO RAPIDO:** Stringere il montaggio rapido fino a quando la spalla è a filo con il pannello, non stringere troppo o troppo poco.

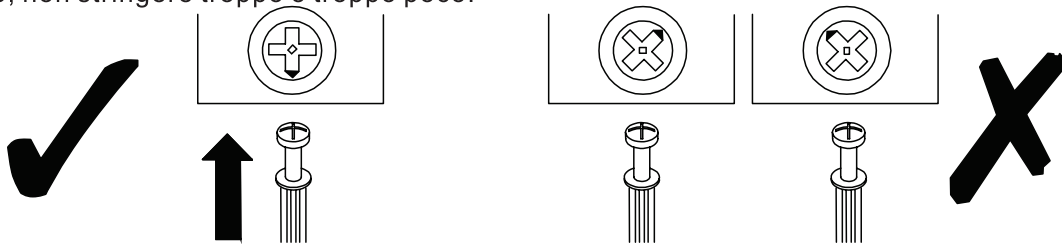

**EN\_CAM LOCK:** When fitting cam lock, ensure starting position is correct before you insert connecting quickfit.

**FR\_SERRURE BATTEUSE:** Avant d'insérer la serrure batteuse, veillez à la bonne orientation avant d'insérer le raccord rapide.

**ES\_CIERRE DE LA CÁMARA:** Cuando instale el cierre de la cámara, asegúrese de que la posición de inicio es correcta antes de que inserte el quickfit conector.

**PT\_BLOQUEIO:** Ao instalar o bloqueio, assegurar-se de que a posição inicial está correcta antes de inserir o encaixe de ligação rápida.

**DE\_CAM-LOCK:** Achten Sie bei der Montage des Cam-Locks auf die richtige Ausgangsposition, bevor Sie den Quickfit einsetzen.

**IT\_BLOCCAGGIO A CAMMA:** Quando si monta il bloccaggio a camma, assicurarsi che la posizione iniziale sia corretta prima di inserire il montaggio rapido di collegamento.

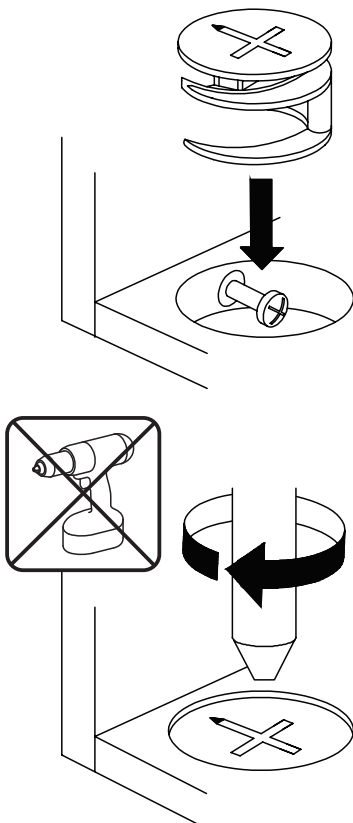

**EN\_Quickfit head should be in the centre of the cam lock when the two panels are joined.**

Cam lock should be inserted before quickfit.

**FR\_**Lorsque les deux panneaux sont assemblés, la tête du raccord rapide doit reposer au centre de la serrure batteuse.

Il faut insérer la serrure batteuse avant le raccord rapide.

**ES\_**El cabezal del quickfit debe estar en el centro del cierre de la cámara cuando se unan los dos paneles.

Se debe insertar el cierre de la cámara antes que el quickfit.

**PT\_**A cabeça de ajuste rápido deve estar no centro da fechadura quando os dois painéis estão unidos.

A fechadura de cames deve ser inserida antes de ser rápida.

**DE\_**Der Quickfit-Kopf sollte sich in der Mitte des Cam-Locks befinden, wenn die beiden Platten zusammengefügt sind.

Der Cam-Lock sollte vor dem Quickfit eingesetzt werden.

**IT\_**La testa del montaggio rapido deve trovarsi al centro del bloccaggio a camma quando i due pannelli sono uniti.

Il Bloccaggio a Camma deve essere inserito prima del montaggio rapido.

**EN\_**Turn cam lock clockwise to tighten.

**FR\_**Faites tourner la serrure batteuse dans le sens des aiguilles d'une montre pour la resserrer.

**ES\_**Gire el cierre de la cámara en sentido horario para apretarlo.

**PT\_**Rodar o bloqueio no sentido dos ponteiros do relógio para o apertar.

**DE\_**Drehen Sie den Cam-Lock im Uhrzeigersinn, um ihn festzuziehen.

**IT\_**Ruotare il bloccaggio a camma in senso orario per stringere.

**IF HAVE THIS ACCESSORY**

**NOTE DIFFERENT MODELS**

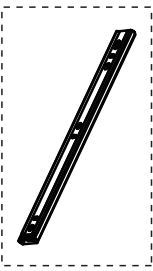

**EN\_NOTE:** Pull inner and outer drawer runners apart before fixing them to panels.

**FR\_REMARQUE:** Avant de fixer les glissières de tiroir aux panneaux, tirez vers l'extérieur et poussez vers l'intérieur de chacun des tiroirs.

**ES\_NOTA:** retire los rieles interiores y exteriores antes de fijarlos a los panales.

**PT\_NOTA:** Separar as corrediças das gavetas interiores e exteriores antes de fixar para os painéis.

**DE\_HINWEIS:** Ziehen Sie die inneren und äußeren Schubladenführung auseinander, bevor Sie sie an den Platten befestigen.

**IT\_NOTA:** Separare le guide interne ed esterne del cassetto prima di fissarle ai pannelli.

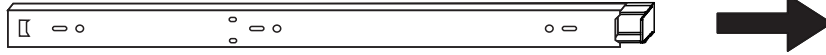

**EN\_Slide** drawer runners apart until the drawer lock can be seen, as shown.

**FR\_Les** glissières de tiroir doivent être ouvertes jusqu'à ce que la serrure du tiroir soit visible, comme indiqué.

**ES\_Deslice** a un lado los rieles del cajón hasta que se pueda ver el cierre del armario, tal y como se muestra.

**PT\_Deslizam-se** as gavetas até se poder ver o fecho da gaveta, como se mostra.

**DE\_Schieben** Sie die Schubladenführungen auseinander, bis das Schubladenschloss sichtbar ist, gemäß der Abbildung.

**IT\_Far** scorrere le guide del cassetto fino a quando non sia visibile il blocco di scorrimento, come mostrato.

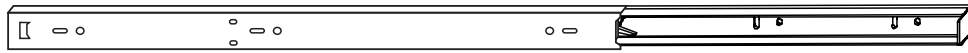

**OUTER RUNNER**

**INNER RUNNER**

**EN\_Press** and hold the drawer runner lock and then continue to slide drawer runners apart, as shown.

**FR\_En** appuyant et en maintenant le verrouillage des glissières de tiroir, vous pouvez continuer à les écarter l'une de l'autre, comme indiqué.

**ES\_Mantenga** presionado el cierre del riel del cajón y después continúe deslizando a un lado los rieles de los cajones, tal y como se muestra.

**PT\_Manter** pressionado o fecho de gaveta e depois continuar a deslizar as corrediças da gaveta, como mostrado.

**DE\_Drücken** und halten Sie die Verriegelung der Schubladenführung und schieben Sie die Schubladenführungen wie abgebildet weiter auseinander.

**IT\_Tenere** premuto il blocco di scorrimento e quindi continuare a far scorrere la guida, come mostrato.

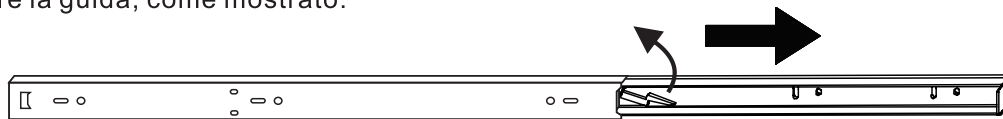
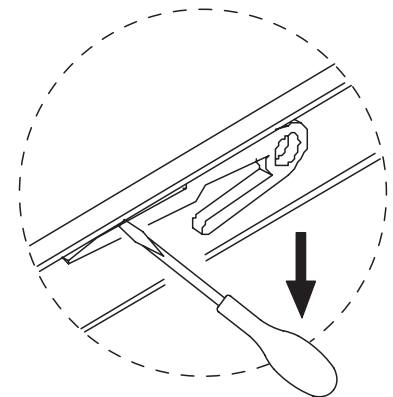

**OUTER RUNNER**

**INNER RUNNER**

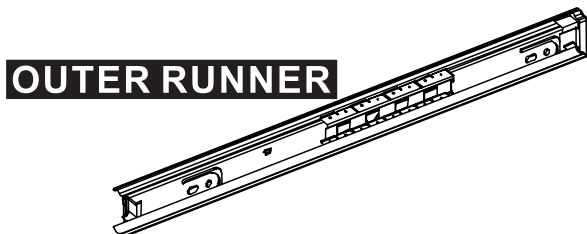

**OUTER RUNNER**

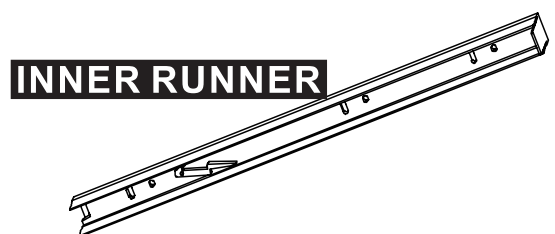

**INNER RUNNER**

**EN\_Your** inner and outer drawer runners are ready to be fixed to panels.

**FR\_Il** est possible, à présent, de fixer les glissières intérieures et extérieures de vos tiroirs sur des panneaux.

**ES\_Los** rieles interiores y exteriores del cajón están listos para fijarse a los paneles.

**PT\_As** corrediças das gavetas interiores e exteriores estão prontas para serem fixadas nos painéis.

**DE\_Ihre** inneren und äußeren Schubladenführungen sind bereit, an den Platten befestigt zu werden.

**IT\_Le** guide interne ed esterne sono pronte per essere fissate ai pannelli.

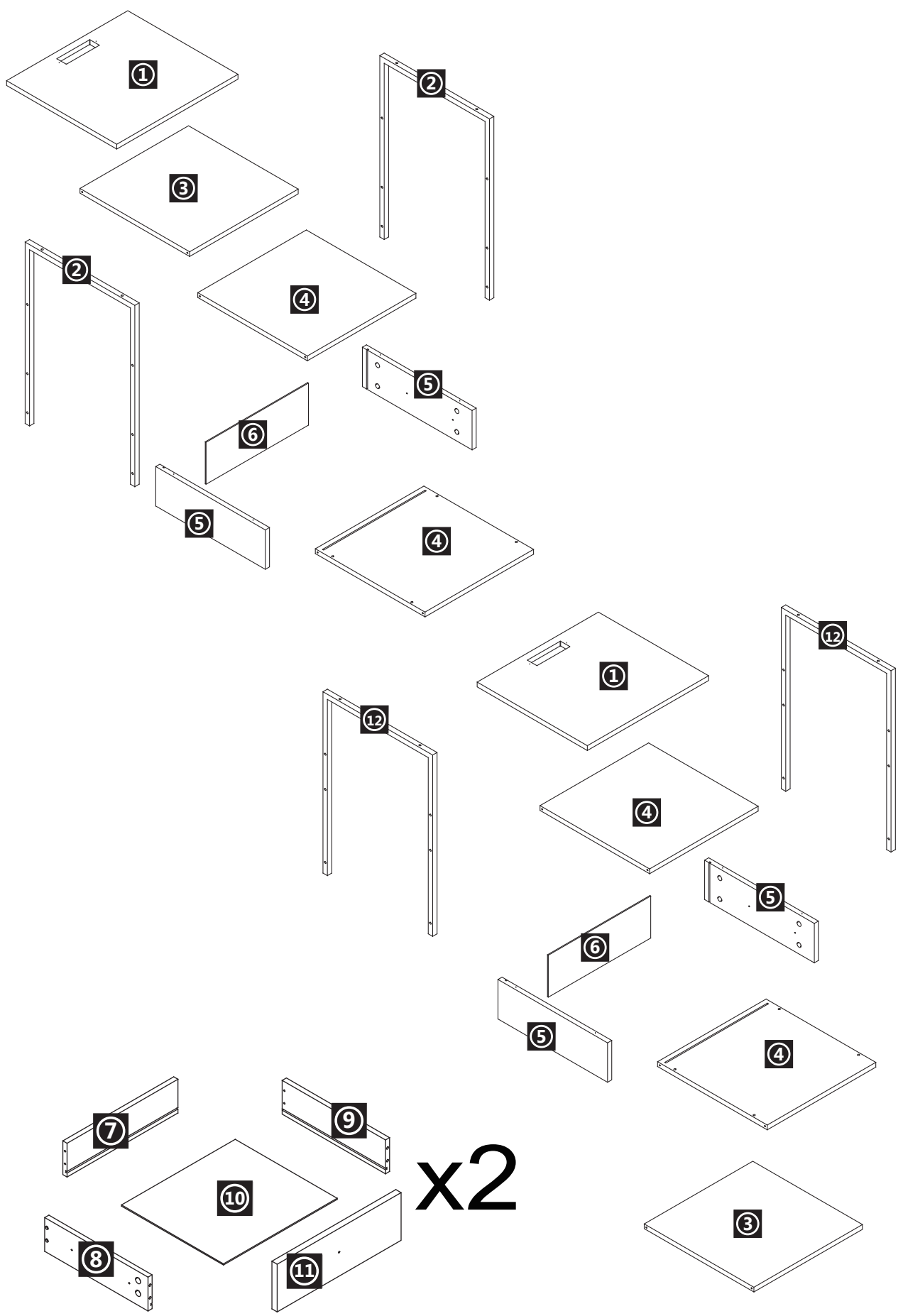

x2



① x2

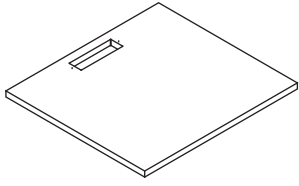

② x2

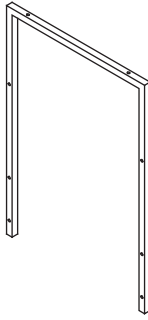

③ x3

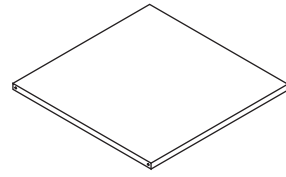

④ x4

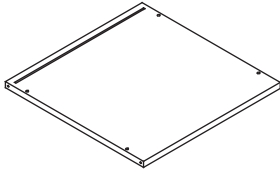

⑤ x4

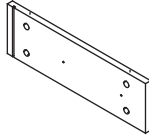

⑥ x2

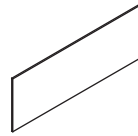

⑦ x2

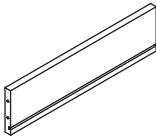

⑧ x2

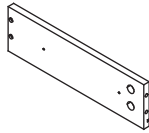

⑨ x2

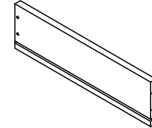

⑩ x2

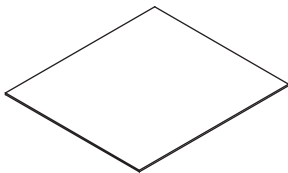



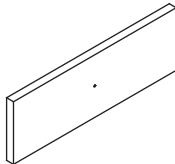



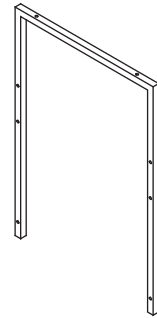

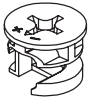
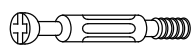

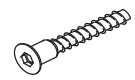

⑪ x2

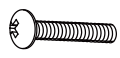

⑫ x2

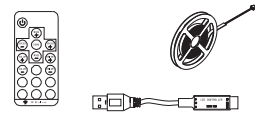
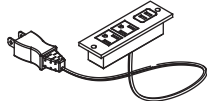

	<b>A</b> x16 M15*12 +1(spare)		<b>B</b> x24 M6*40 +1(spare)		<b>C</b> x08 M15*9 +1(spare)
	<b>D</b> x16 M4*12 +1(spare)		<b>E</b> x08 M6*25 +1(spare)		<b>F</b> x24 M7*35 +1(spare)
	<b>G</b> x02	 	<b>H</b> x02		<b>I</b> x04
	<b>J</b> x04		<b>K</b> x08 M4*30 +1(spare)		<b>L</b> x02
	<b>M</b> x02		<b>N</b> x08		<b>O</b> x01

**IF HAVE THIS ACCESSORY**

NOTE DIFFERENT MODELS



- EN*\_ Adjust up and down for balance
- FR*\_ Ajuster l'équilibre vers le haut et le bas
- ES*\_ Ajuste hacia arriba y abajo para equilibrar
- PT*\_ Ajustar para cima e para baixo para obter equilibrio
- DE*\_ Nach oben und unten für das Gleichgewicht einstellen
- IT*\_ Regolare il bilanciamento verso l'alto e verso il basso

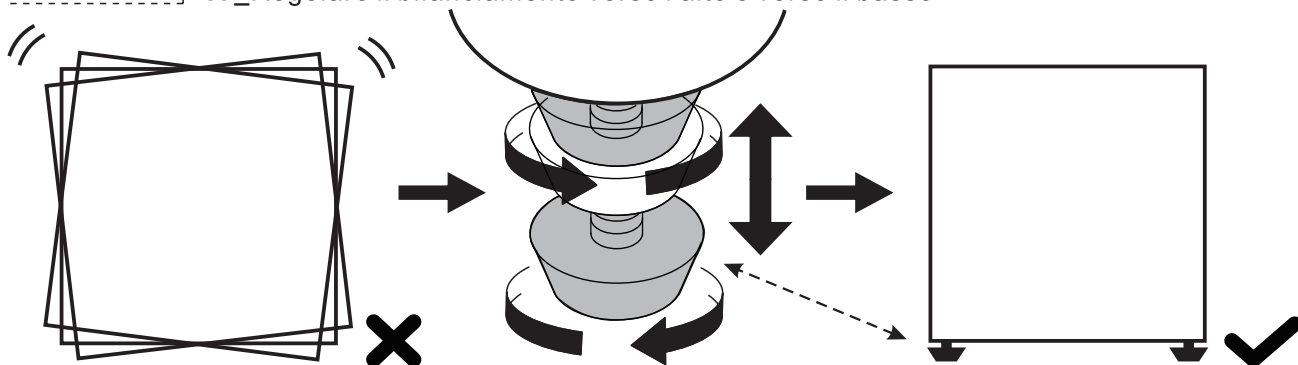

B x16

D x 8

I x 4

x4

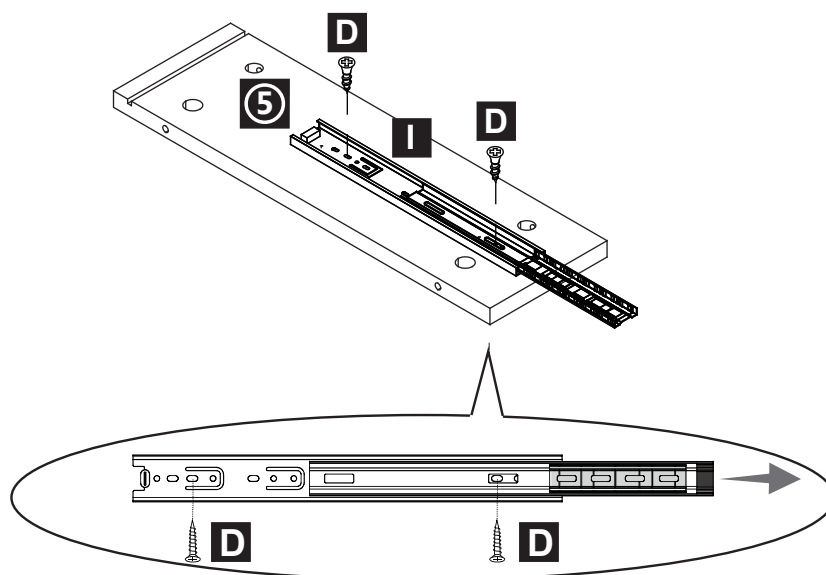
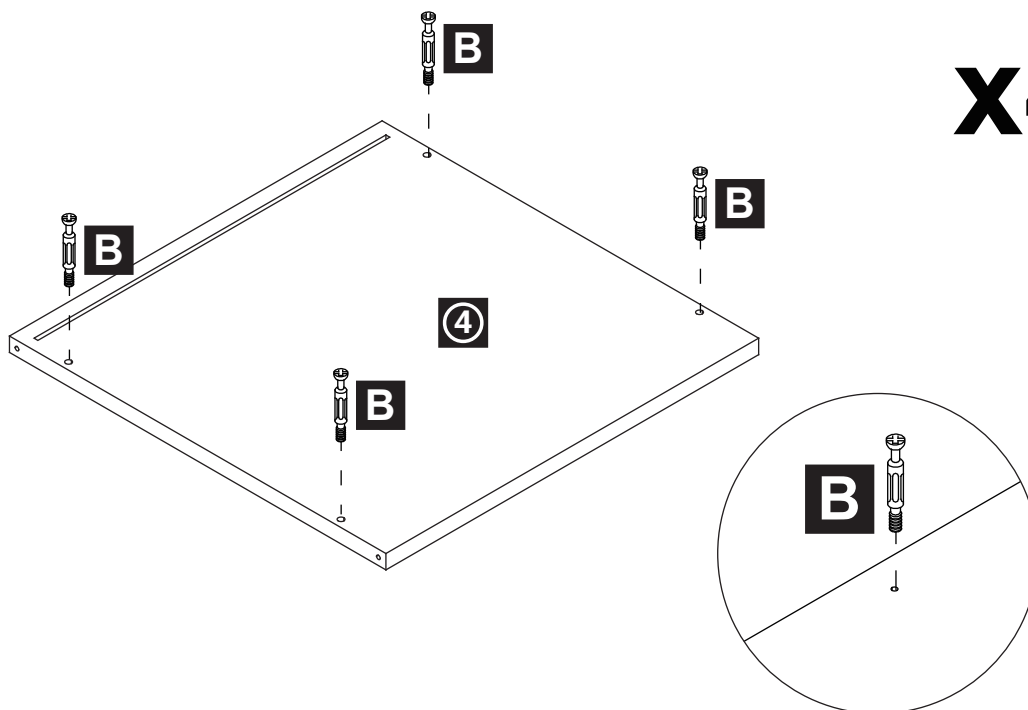

**EN** Please find the exact hole for installation, otherwise it will be misaligned. The screws on the drawer slide must be leveled, otherwise it will affect the smoothness of the drawer.

**FR** Identifiez le trou exact pour l'installation, sinon il sera mal aligné. Les vis de la glissière du tiroir doivent être nivelées, sinon cela affectera le fonctionnement du tiroir.

**ES** Al instalar, encuentre el orificio exacto; de lo contrario, estará desalineado. Los tornillos en las correderas del cajón deben estar nivelados, de lo contrario, afectará la suavidad al deslizar el cajón.

**PT** Por favor encontre o orifício exacto para instalação, caso contrário será desalinhado. Os parafusos na corredeira da gaveta devem ser nivelados, caso contrário afetará a suavidade da abertura da gaveta.

**DE** Bitte finden Sie das genaue Loch für die Installation, sonst wird es falsch ausgerichtet werden. Die Schrauben an der Schubladenföhrung müssen nivelliert werden, da sonst die Leichtgängigkeit der Schublade beeinträchtigt wird.

**IT** individuare il foro esatto per l'installazione, altrimenti ci sarà un disallineamento. Le viti sulla guida del cassetto devono essere allineate, altrimenti influirà sulla scorrevolezza del cassetto.

A x 8

x2

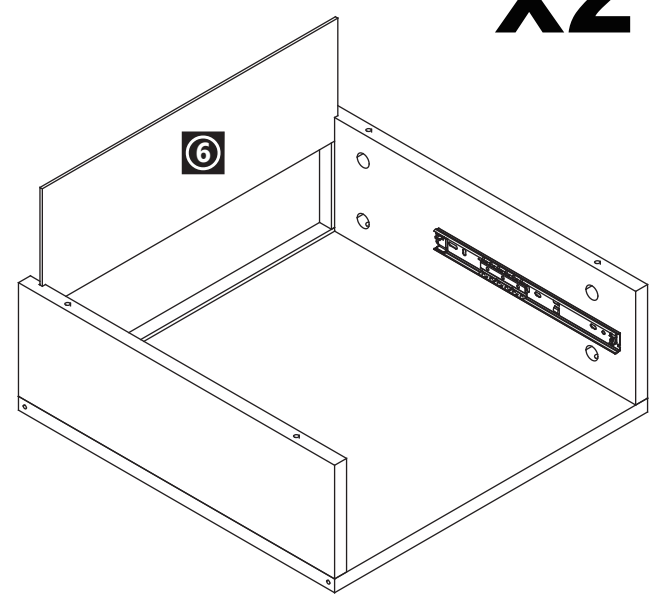
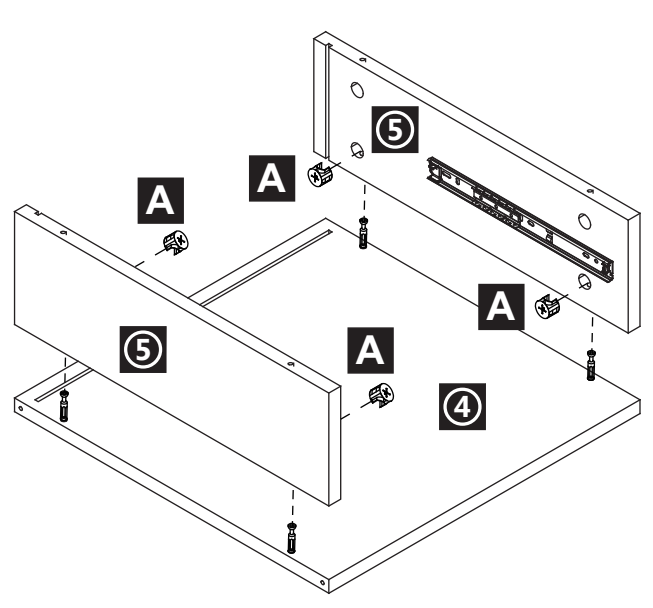

A x 8

x2

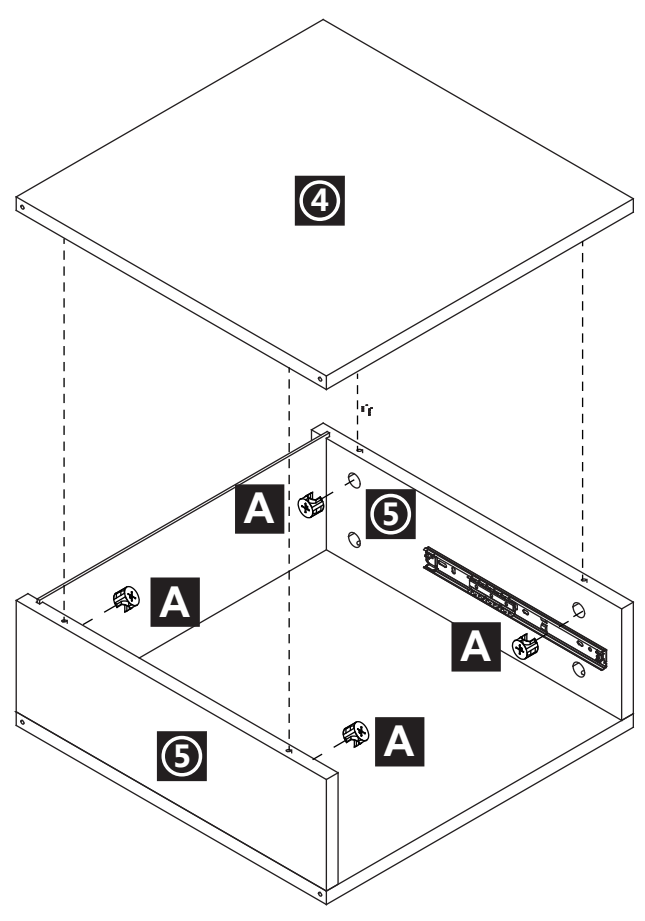

F x12

O x 1

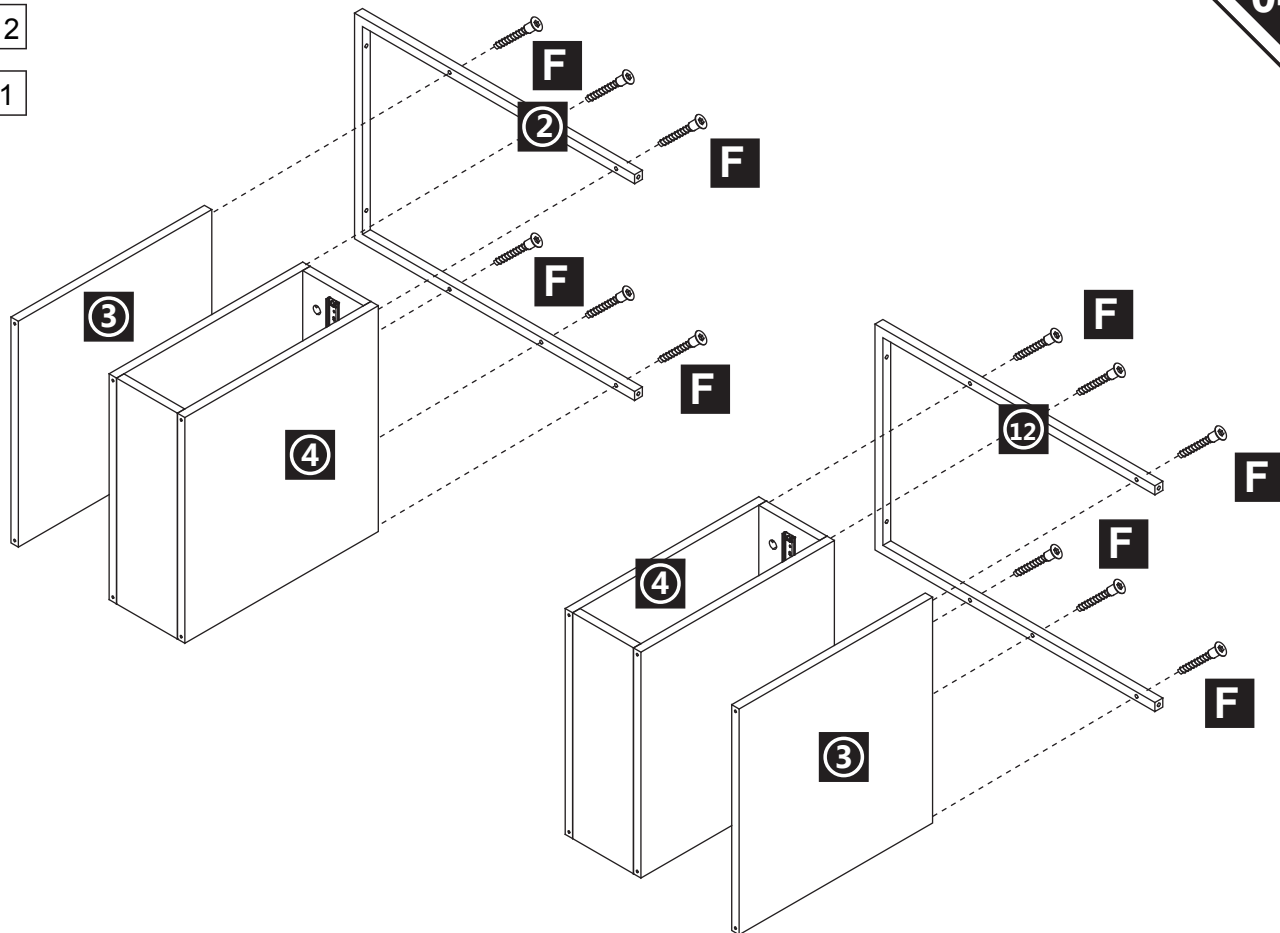

F x12

O x 1

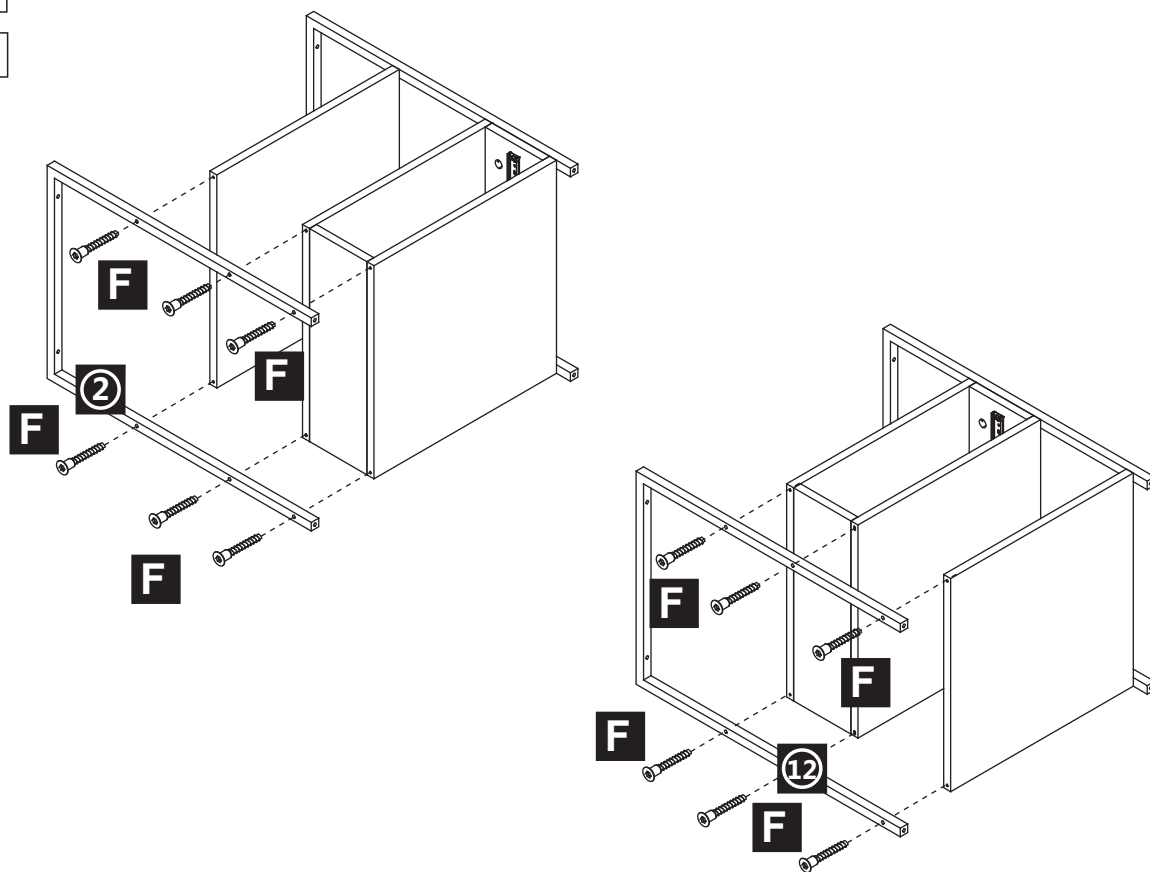

E x 8

N x 8

O x 1

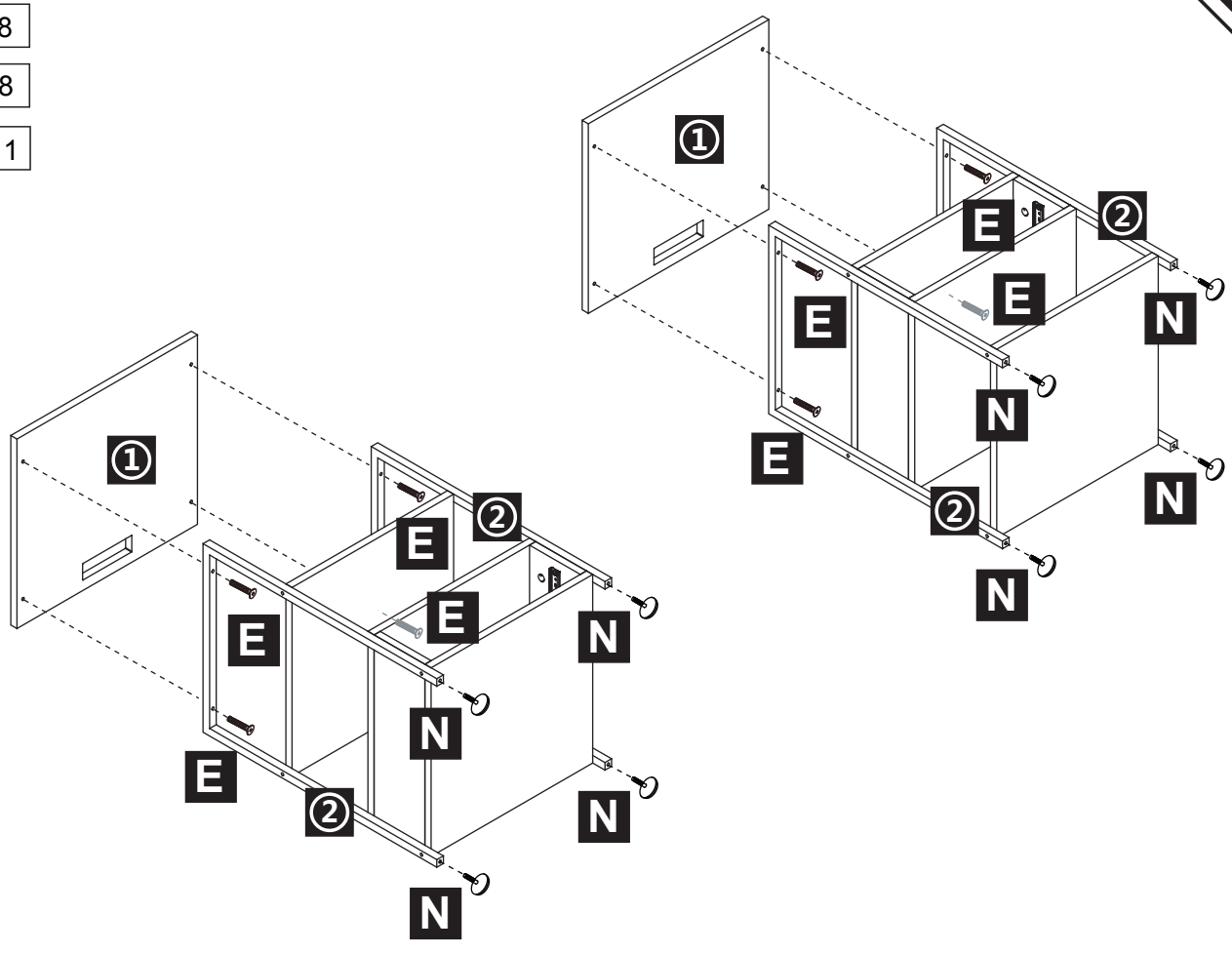

L x 2

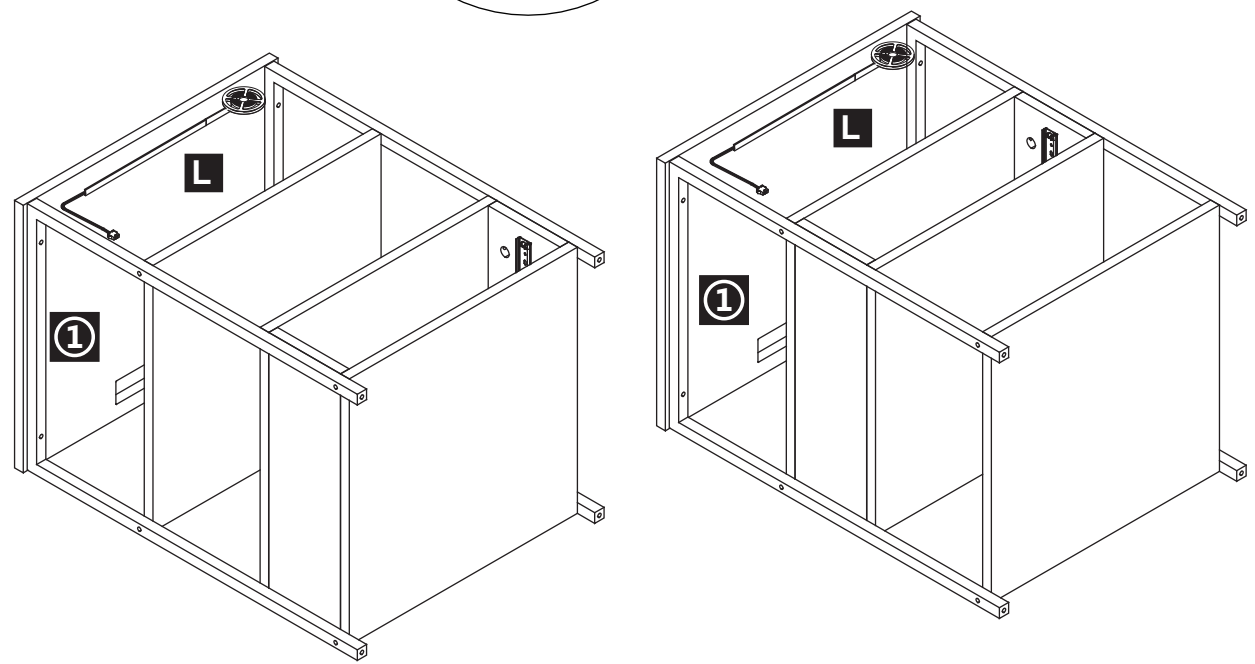
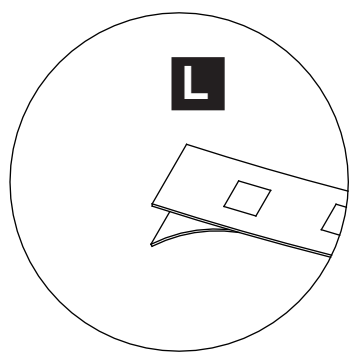



B x 8

G x 2

H x 2

K x 8

x2

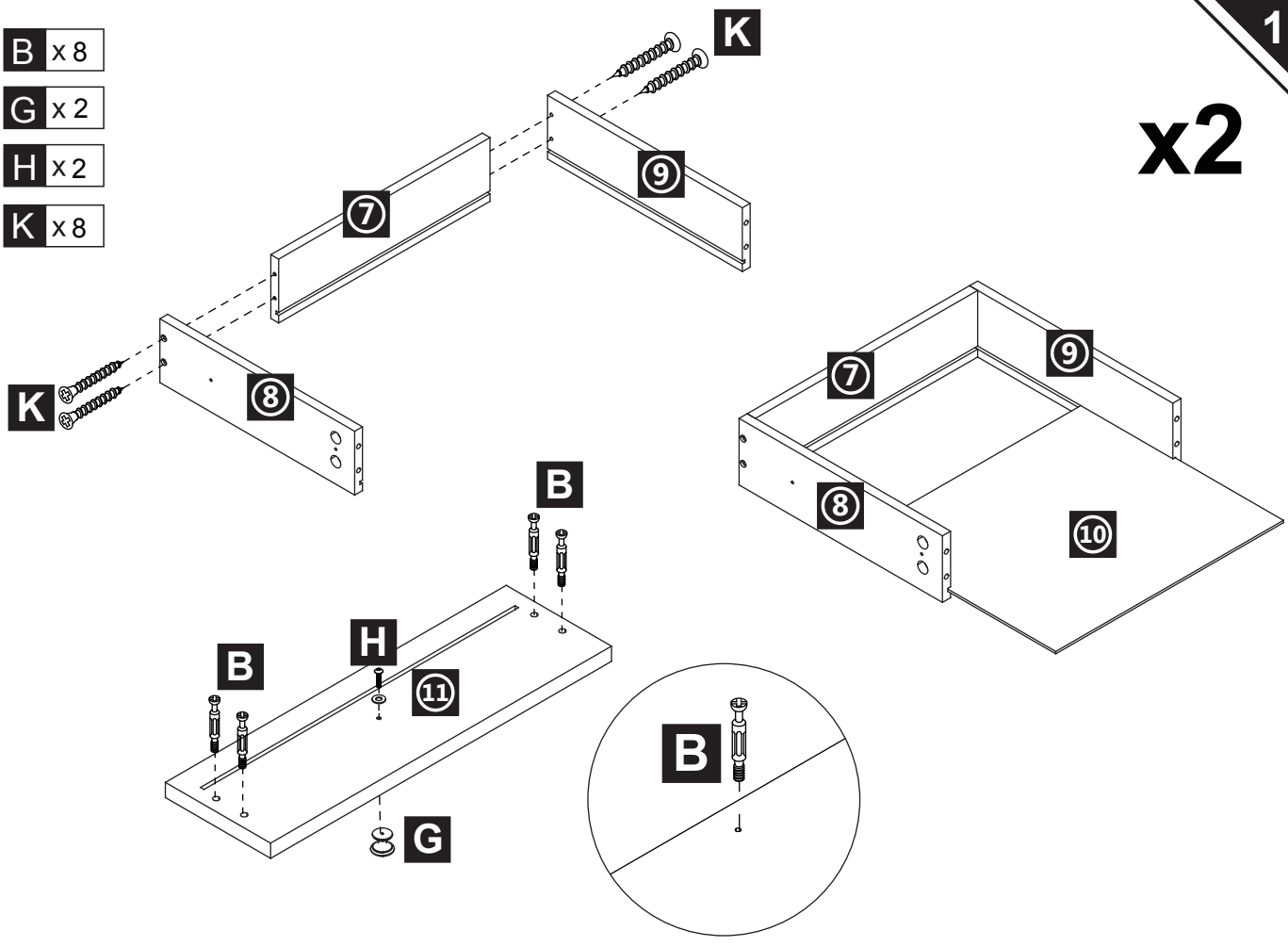

C x 8

D x 8

J x 4

x2

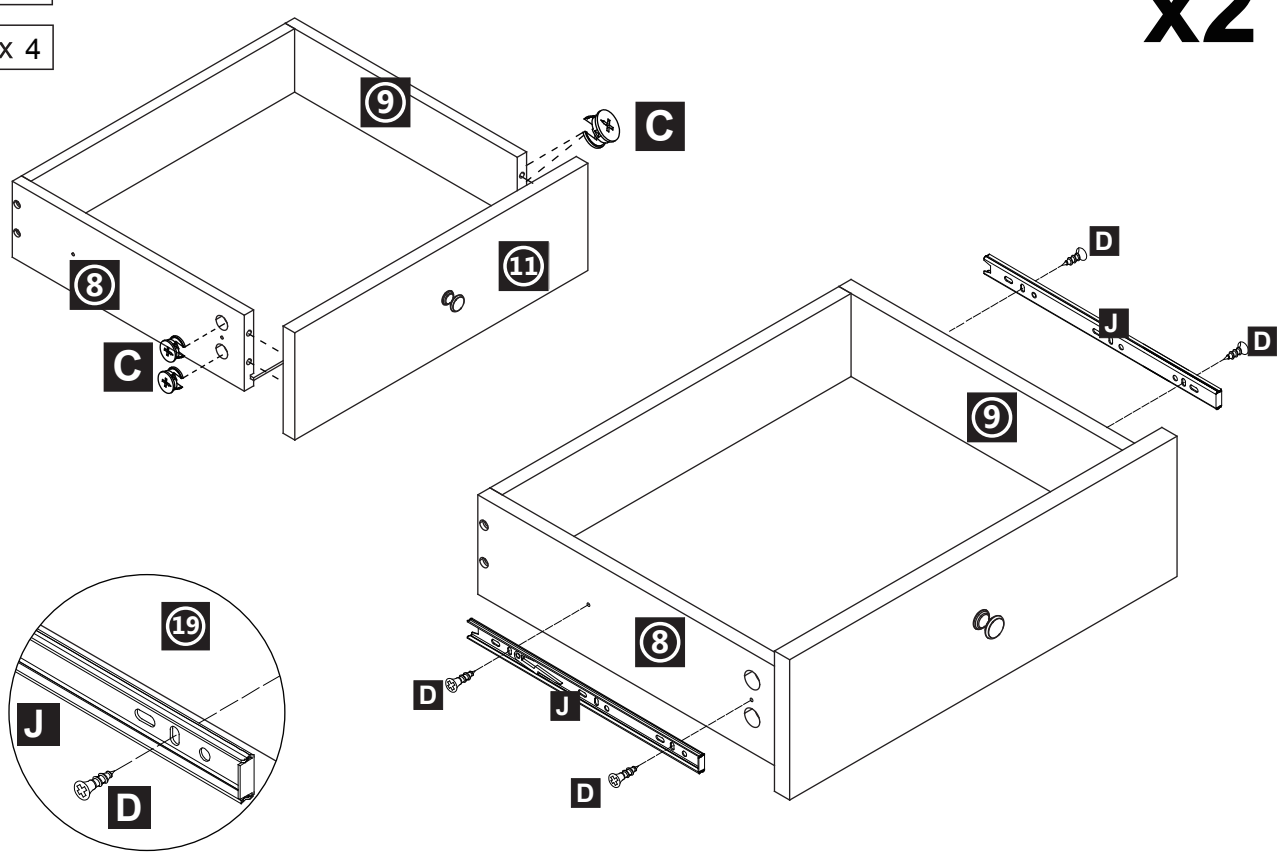

D x 4

G x 2

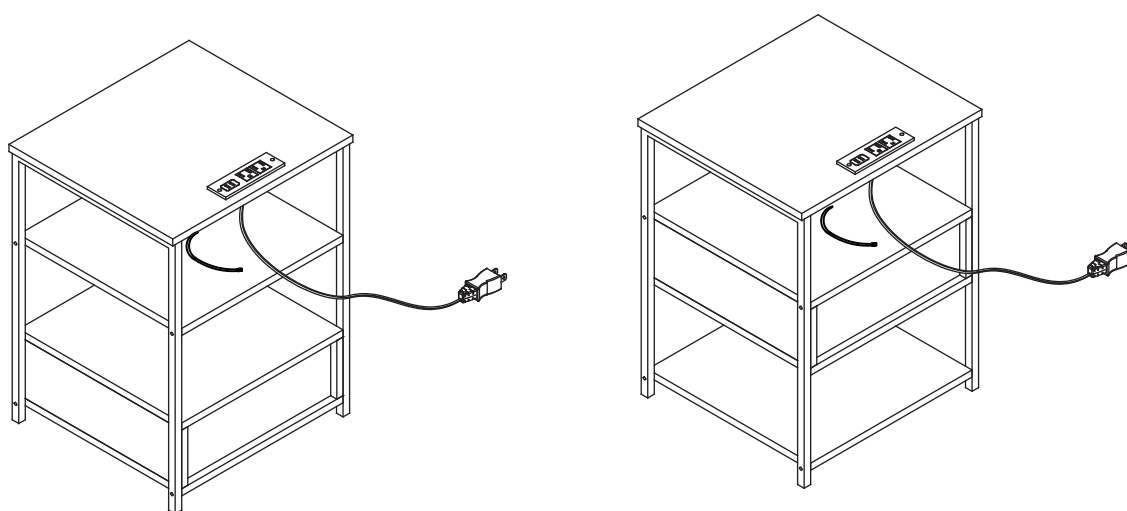
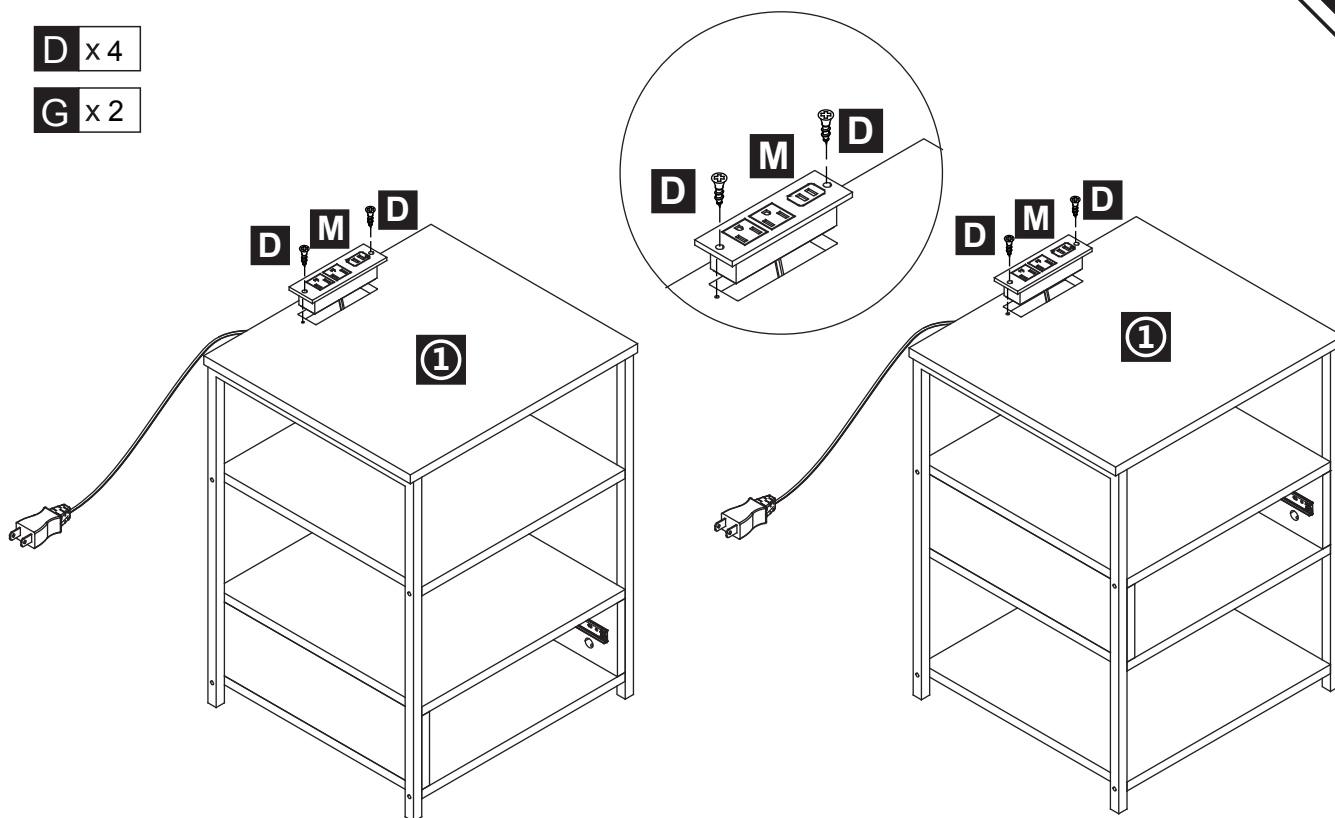

Input voltage	110-240	V
Input AC frequency	50-60	Hz
Output voltage	5	V
Output current	2	A
Output power	10	W
Average active efficiency	78	%
No-load power consumption	0.1	W



L

EN\_Pull out the plastic sheet before use.  
 FR\_Retirer la feuille de plastique avant utilisation.  
 ES\_Retire la lámina de plástico antes de utilizarlo.  
 PT\_Retirar a folha de plástico antes de utilizar.  
 DE\_Ziehen Sie die Plastikfolie vor dem Gebrauch heraus.  
 IT\_Estrarre il foglio di plastica prima dell'uso.

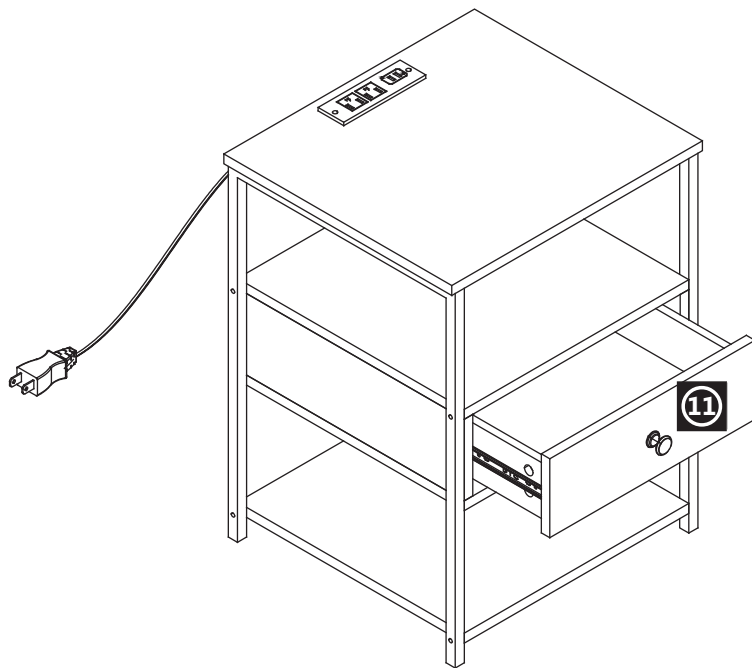
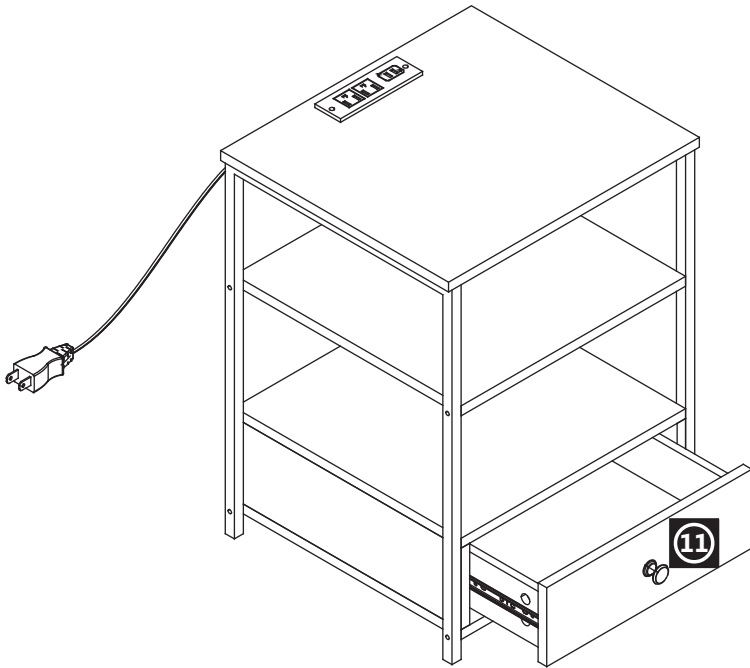

- EN** Be careful to push in the board when the both sides slide way been aligned.
- FR** Prenez soin d'enfoncer la planche lorsque les deux côtés de la glissière sont alignés.
- ES** Empuje con cuidado el tablero después de que los dos lados se hayan alineado.
- PT** Ter o cuidado de empurrar a placa quando os dois lados estiverem alinhados.
- DE** Achten Sie darauf, dass Sie die Platte einschieben, wenn die beiden Seiten so ausgerichtet sind, dass sie gleiten.
- IT** Fare attenzione quando si spinge il cassetto quando le due guide di scorrimento sono state allineati.

**EN\_16** level brightness Adjusting  
**FR\_16** niveaux de luminosité Réglage  
**ES\_16** niveles de brillo Ajuste  
**PT\_16** níveis de luminosidade Ajuste  
**DE\_16** Stufen Helligkeit Einstellen  
**IT\_16** livelli di luminosità Regolazione

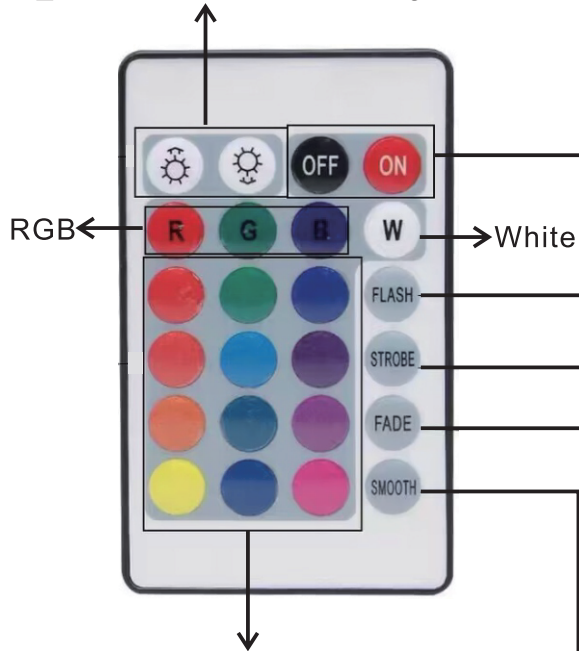

**EN\_12** kinds of existing colors  
**FR\_12** types de couleurs existantes  
**ES\_12** tipos de colores existentes  
**PT\_12** tipos de cores existentes  
**DE\_12** Arten von vorhandenen Farben  
**IT\_12** tipi di colori esistenti

**EN\_** Power off/Power On  
**FR\_** Mise hors tension/mise sous tension  
**ES\_** Apagado/Encendido  
**PT\_** Desligar/ligar  
**DE\_** Ausschalten/Einschalten  
**IT\_** Spegnimento/Accensione

**EN\_16** colors jump change  
**FR\_16** colori di salto  
**ES\_** Cambio de salto de 16 colores  
**PT\_** Mudança de salto de 16 cores  
**DE\_16** Farben Sprungwechsel  
**IT\_16** colori di salto

**EN\_16** colors jump change  
**FR\_16** colori di salto  
**ES\_** Cambio de salto de 16 colores  
**PT\_** Mudança de salto de 16 cores  
**DE\_16** Farben Sprungwechsel  
**IT\_16** colori di salto

**EN\_16** colors fade change  
**FR\_16** couleurs changeantes  
**ES\_** Cambio de 16 colores  
**PT\_16** cores com mudança de cor  
**DE\_16** Farben verblassen ändern  
**IT\_16** colori cambiano in dissolvenza

**EN\_16** colors fade change  
**FR\_16** couleurs changeantes  
**ES\_** Cambio de 16 colores  
**PT\_16** cores com mudança de cor  
**DE\_16** Farben verblassen ändern  
**IT\_16** colori cambiano in dissolvenza

## ⚠ WARNING

- **INGESTION HAZARD:** This product contains a button cell or coin battery.
- **DEATH** or serious injury can occur if ingested.
- A swallowed button cell or coin battery can cause **Internal Chemical Burns** in as little as **2** hours.
- **KEEP** new and used batteries **OUT OF REACH** of **CHILDREN**
- **Seek immediate medical attention** if a battery is suspected to be swallowed or inserted inside any part of the body.



### Battery

- 1.) Battery type: CR2025
- 2.) Nominal Voltage 3V

### Instructions and manuals

- a) Remove and immediately recycle or dispose of used batteries according to local regulations and keep away from children. Do NOT dispose of batteries in household trash or incinerate.
- b) Even used batteries may cause severe injury or death.
- c) Call a local poison control center for treatment information.
- d) A statement indicating the compatible battery type Cr2025.
- e) A statement indicating the nominal battery voltage.
- f) Non-rechargeable batteries are not to be recharged.
- g) Do not force discharge, recharge, disassemble, heat above (manufacturer's specified temperature rating) or incinerate. Doing so may result in injury due to venting, leakage or explosion resulting in chemical burns.
- h) Ensure the batteries are installed correctly according to polarity (+ and -).
- l) Do not mix old and new batteries, different brands or types of batteries, such as alkaline, carbon-zinc, or rechargeable batteries.
- j) Remove and immediately recycle or dispose of batteries from equipment not used for an extended period of time according to local regulations.
- k) Always completely secure the battery compartment. If the battery compartment does not close securely, stop using the product, remove the batteries, and keep them away from children.

If you have any questions, please contact our customer care center, Our contact details are below:

**US**

 001-877-644-9366

 customerservice@aosom.com

Imported by Aosom LLC  
27150 SW Kinsman Rd Wilsonville, OR 97070 USA  
MADE IN CHINA

Wenn Sie Fragen haben, wenden Sie sich bitte an unser Kundendienstzentrum, Unsere Kontaktdaten stehen unten:

**DE**

 0049-0(40)-88307530

 service@aosom.de

ADRESSE DES IMPORTEUR/Hersteller/REP:  
MH Handel GmbH  
Wendenstraße 309  
D-20537 Hamburg  
Germany  
IN CHINA HERGESTELLT

If you have any questions, please contact our customer care center, Our contact details are below:

**CA**

 416-792-6088

 customerservice@aosom.ca

Imported by Aosom Canada Inc.  
7270 Woodbine Avenue, Unit 307, Markham,  
Ontario Canada L3R 4B9  
MADE IN CHINA

Si vous avez la moindre question, veuillez contacter notre centre d'assistance à la clientèle, Nos coordonnées sont les suivantes:

 416-792-6088

 customerservice@aosom.ca

Importé par Aosom Canada Inc.  
7270 Woodbine Avenue, unité 307,  
Markham, Ontario Canada L3R 4B9  
FABRIQUÉ EN CHINE

In caso di dubbio, si prega di contattare il nostro centro assistenza clienti, I nostri dettagli di contatto sono di seguito:

**IT**

 0039-0249471447

 clienti@aosom.it

IMPORTATO DA/Produttore/REP:  
AOSOM Italy srl  
Centro Direzionale Milanofiori  
Strada 1 Palazzo F1  
20057 Assago (MI)  
P.I.: 08567220960  
FATTO IN CINA

Si tiene alguna pregunta, comuníquese con nuestro Centro de Atención al Cliente, Nuestros datos de contacto son los siguientes:

**ES**

 0034-931294512

 atencioncliente@aosom.es

IMPORTADOR/Fabricante/REP:  
SPANISH AOSOM, S.L.  
C/ROC GROS, Nº15.08550, ELS HOSTALET DE  
BALENYÀ, SPAIN.  
B66295775  
HECHO EN CHINA

If you have any questions, please contact our customer care center, Our contact details are below:

**UK**

 0044-800-240-4004

 enquiries@mhstar.co.uk

IMPORTER ADDRESS:  
MH STAR UK LTD  
Unit 27, Perivale Park,  
Horsenden lane South  
Perivale, UB6 7RH  
MADE IN CHINA

Se tiver alguma dúvida, por favor contacte o nosso Centro de Atendimento ao Cliente, Os nossos dados de contacto são os seguintes:

**PT**

 0034-931294512

 info@aosom.pt.

IMPORTADOR/Fabricante/REP:  
SPANISH AOSOM, S.L.  
C.ROC GROS N.15, 08550. ELS HOSTALET DE  
BALENYÀ  
FEITO NA CHINA

Si vous avez la moindre question, veuillez contacter notre centre d'assistance à la clientèle, Nos coordonnées sont les suivantes:

**FR**

 0033-1-84166106

 aosom@mhfrance.fr

Importé par/Fabricant/REP:  
MH FRANCE  
2 Rue Maurice Hartmann  
92130 Issy Les Moulineaux  
France  
FABRIQUÉ EN CHINE



**FR**

**DONNEZ**  
OU  
**RECYCLEZ**



OU



OU



ASSOCIATION LIVRAISON DÉCHÈTERIE

Adresses sur [quefairedemesdechets.fr](http://quefairedemesdechets.fr)