

# PawHut

IN240300079V01\_GL

**D02-178V01**

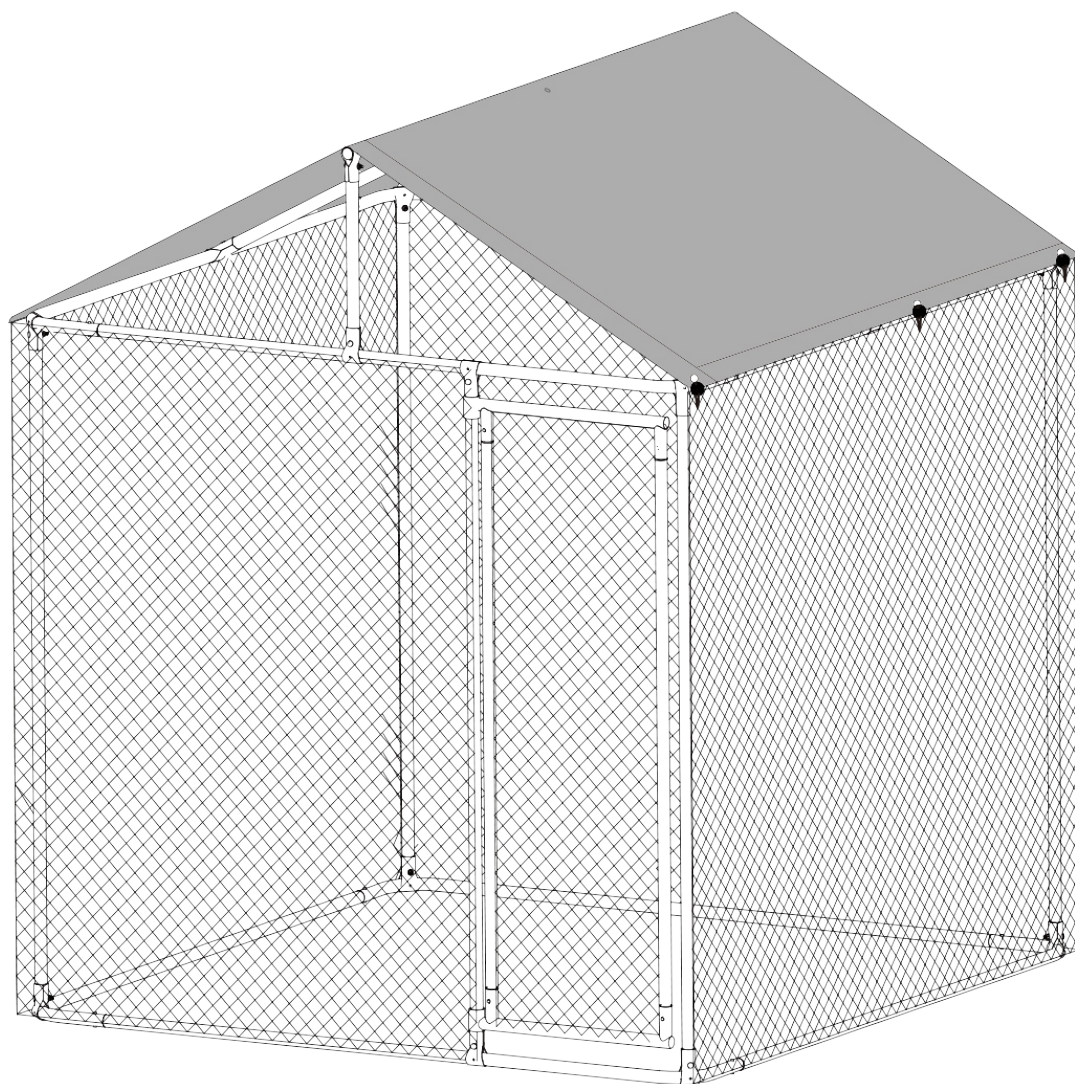

**EN\_IMPORTANT, RETAIN FOR FUTURE REFERENCE: READ CAREFULLY.**

**FR\_IMPORTANT: A LIRE ATTENTIVEMENT ET À CONSERVER POUR CONSULTATION  
ULTÉRIEURE.**

**ES\_IMPORTANTE, LEA Y GUARDE PARA FUTURAS REFERENCIAS.**

**PT\_IMPORTANTE, RETER PARA REFERÊNCIA FUTURA: LEIA ATENTAMENTE.**

**DE\_WICHTIG! SORFGFÄLTIG LESEN UND FÜR SPÄTERES NACHSCHLAGEN AUFBEWAHREN.**

**IT\_IMPORTANTE! CONSERVARE IL PRESENTE MANUALE PER FUTURO RIFERIMENTO E  
LEggerlo ATTENTAMENTE.**

**1** x 8  
250+1800



**3** x 1  
1030



**4** x 1  
1030

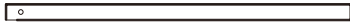

**5** x 2  
1075



**6** x 2  
497



**7** x 2  
1555



**8** x 2

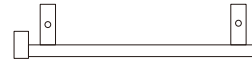

HARDWARE

**A** x36



**B** x18  
+2(spare)



**C** x18  
+2(spare)

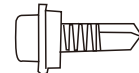

**D** x1

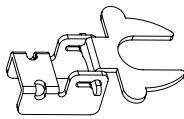

**E** x1



**F** x1



**G** x8



**H**



**I**

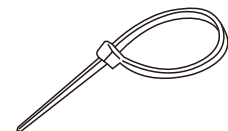

**J** x1

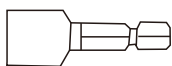

**K** x1



**L** x1

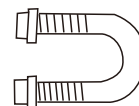

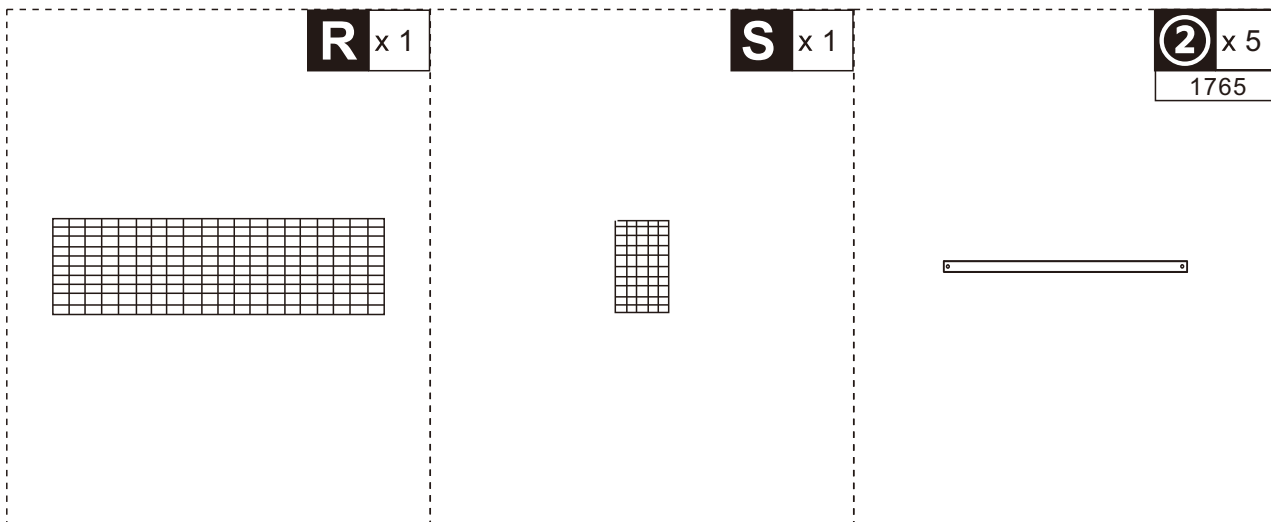

01

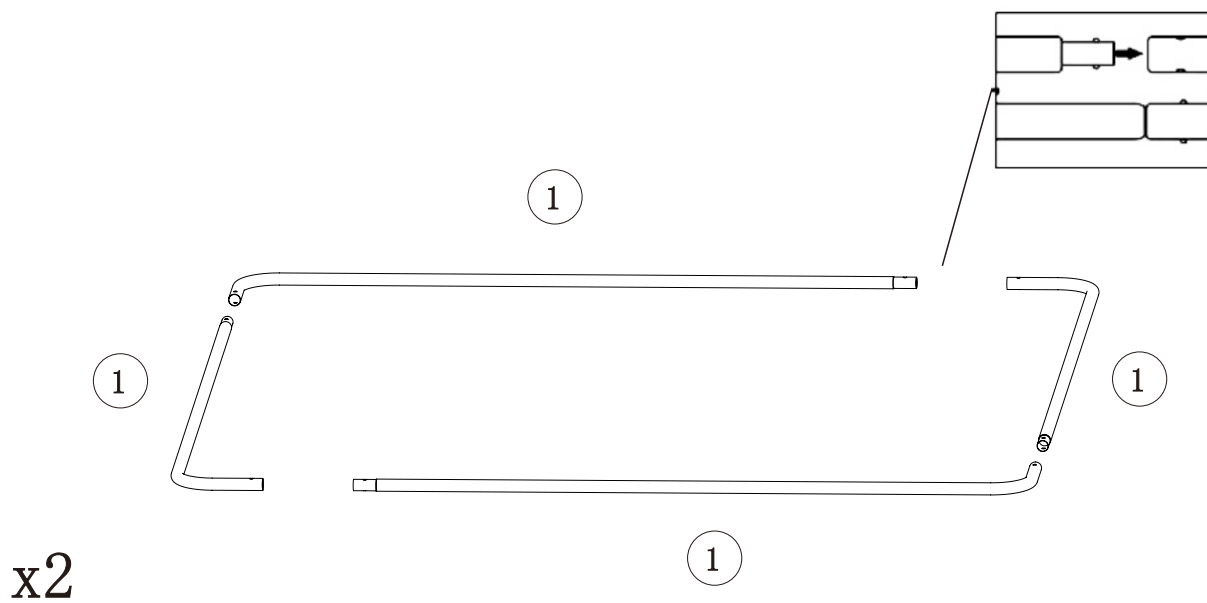

02

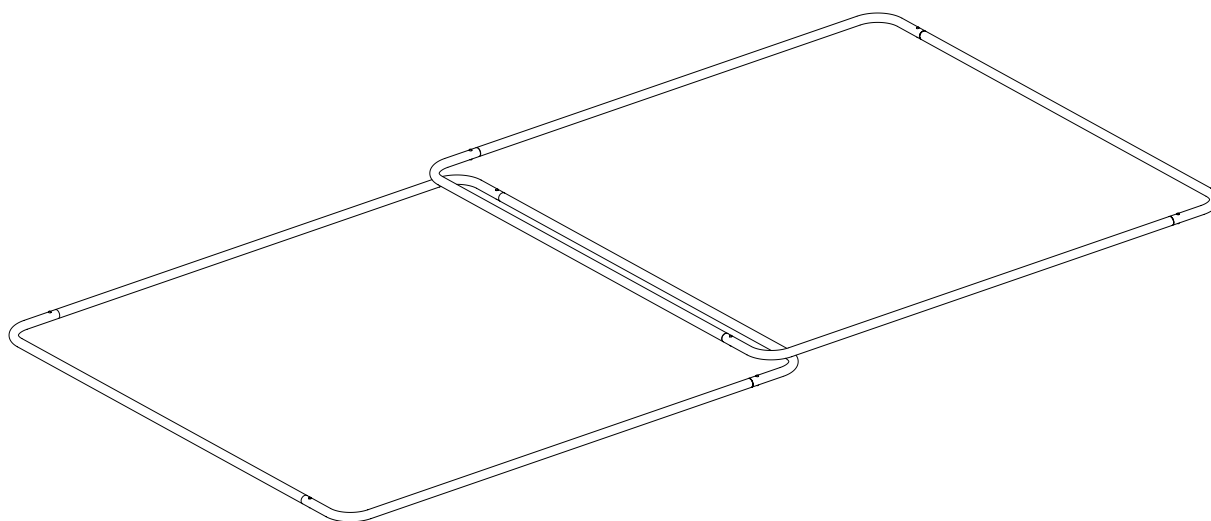

03

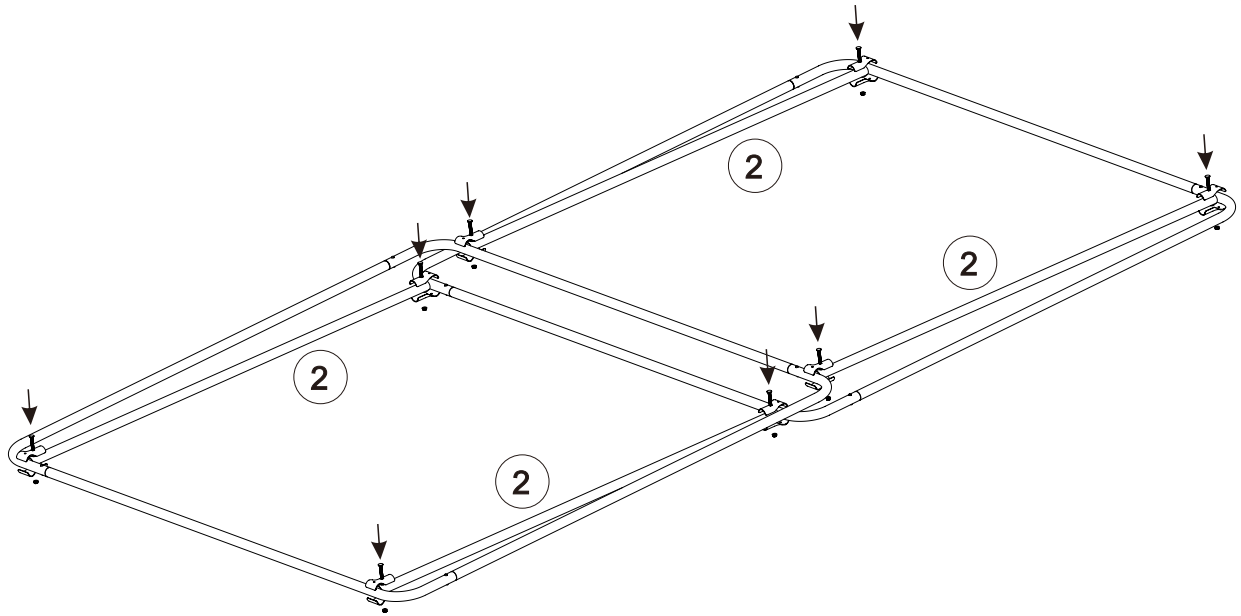

04

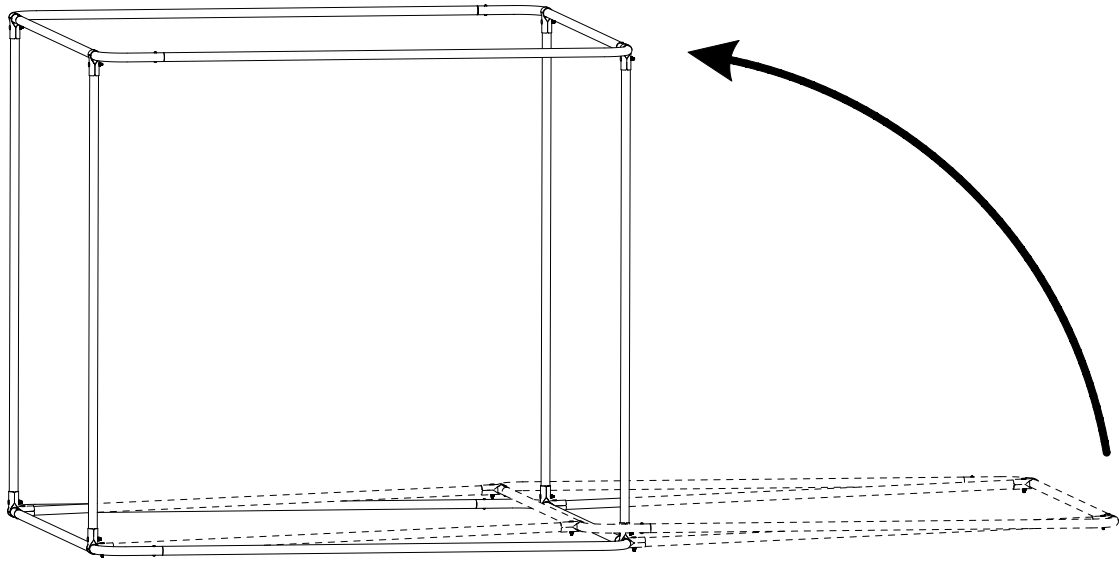

05

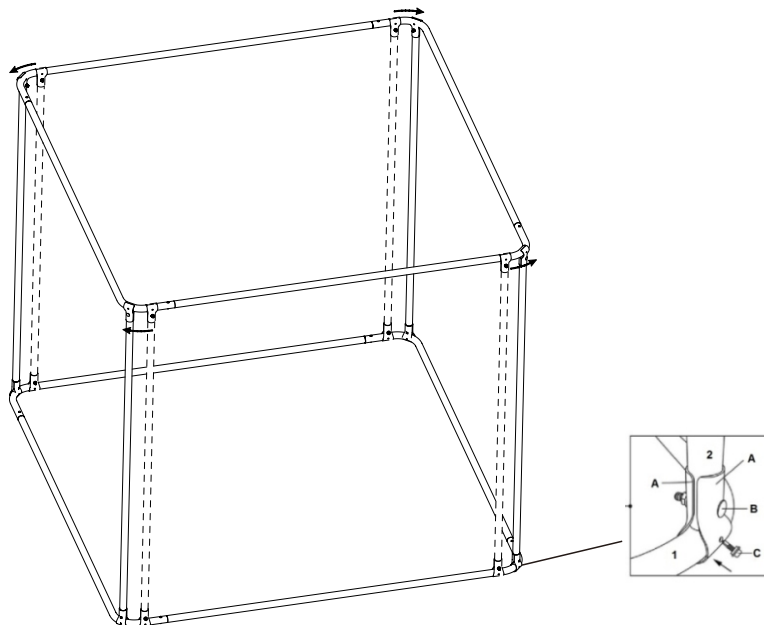

7

8

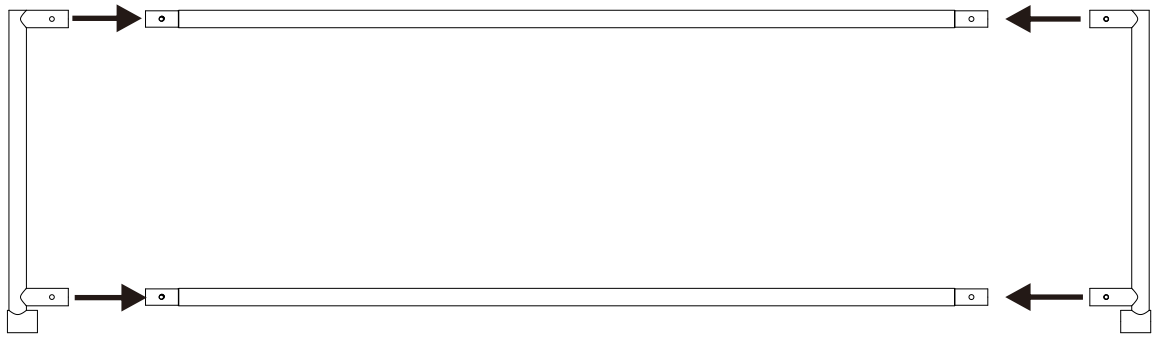

7

8

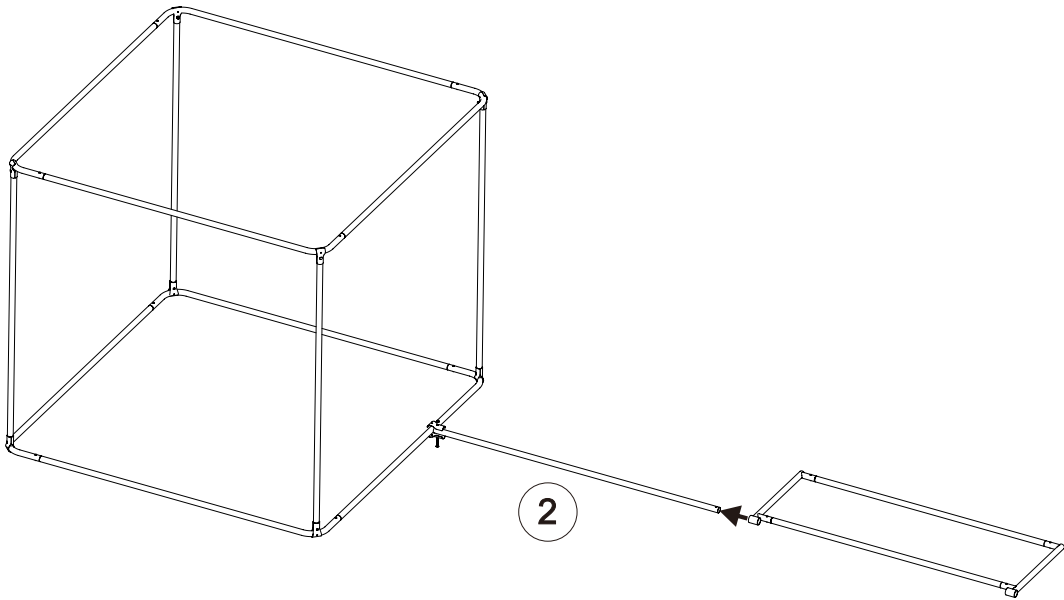

2

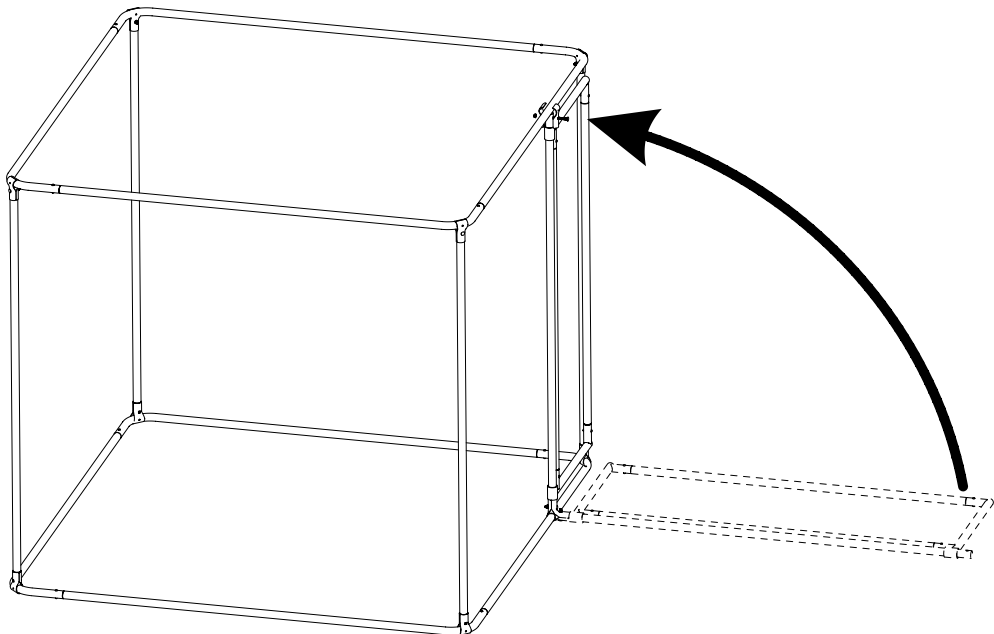

4

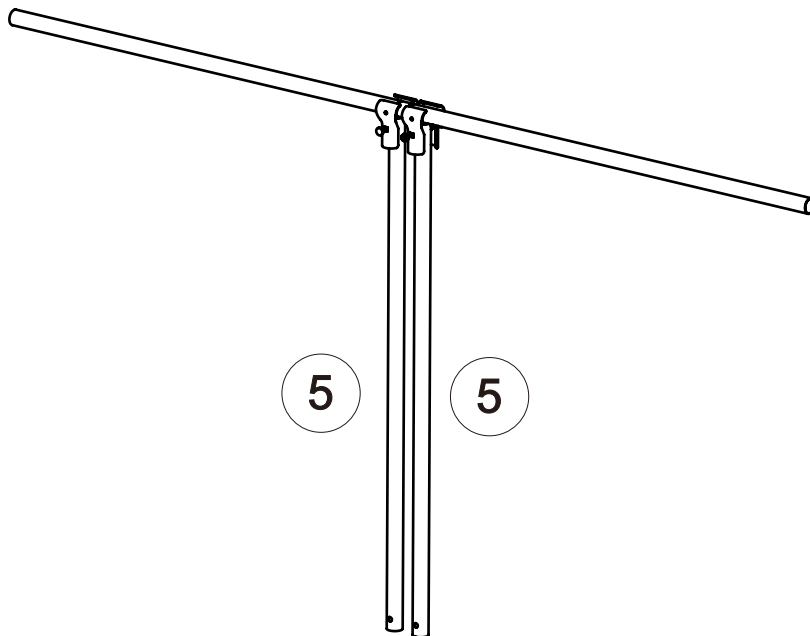
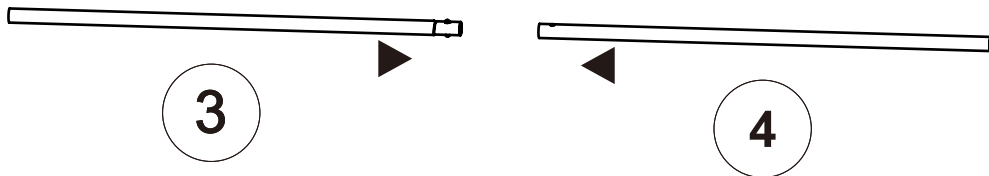
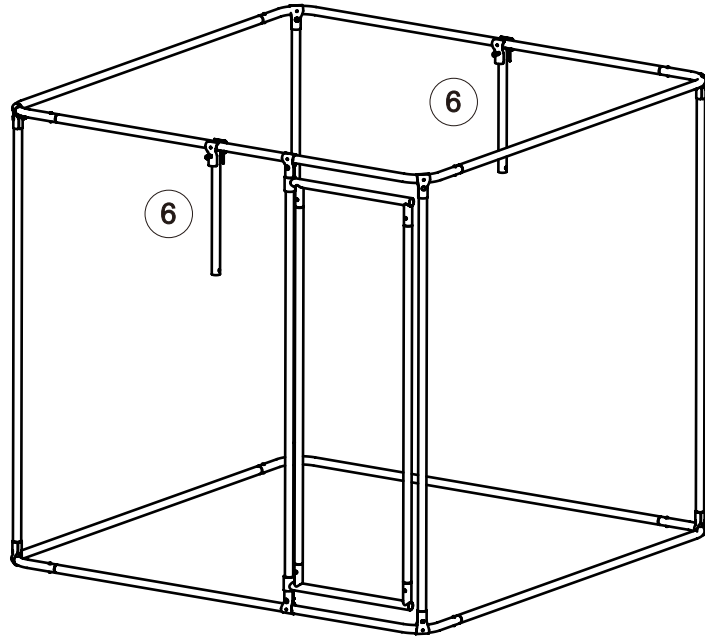

12

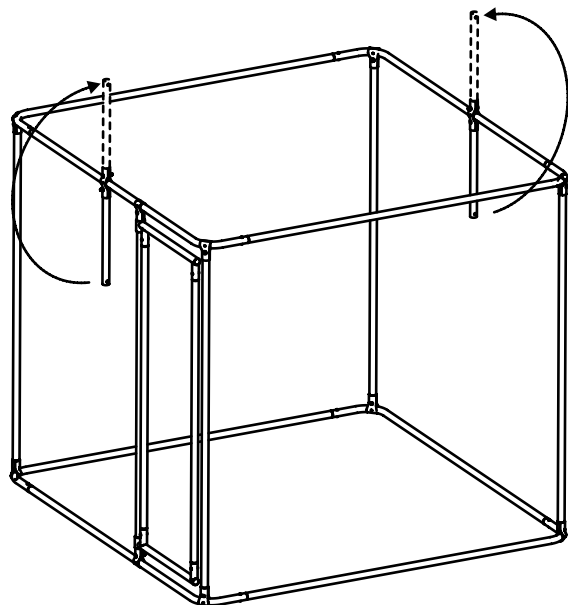

13

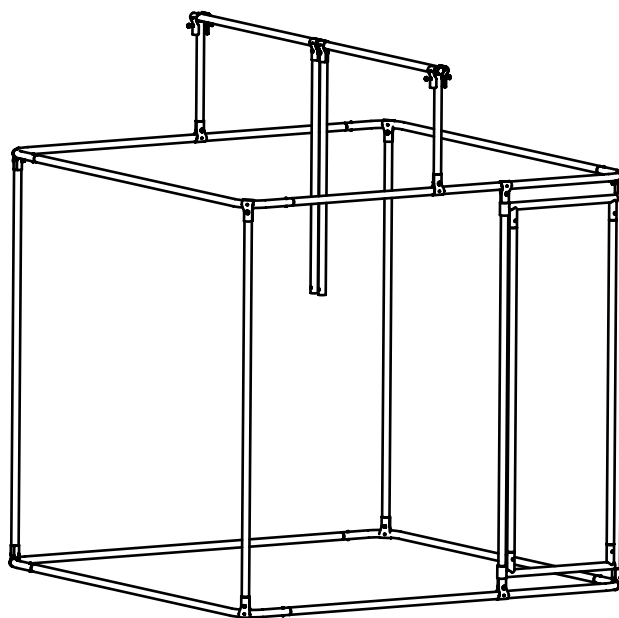

14

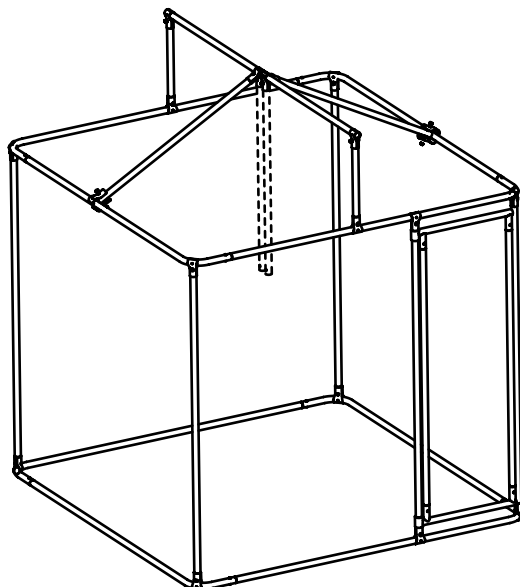

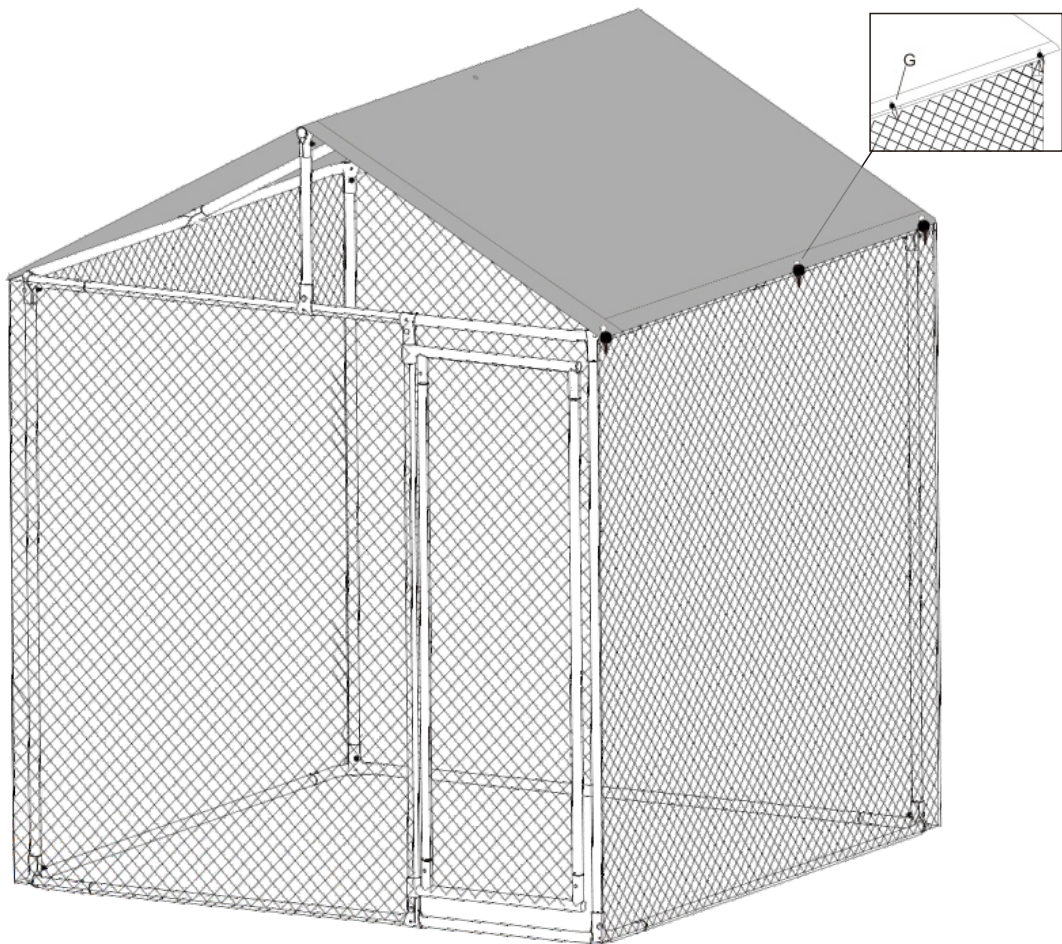
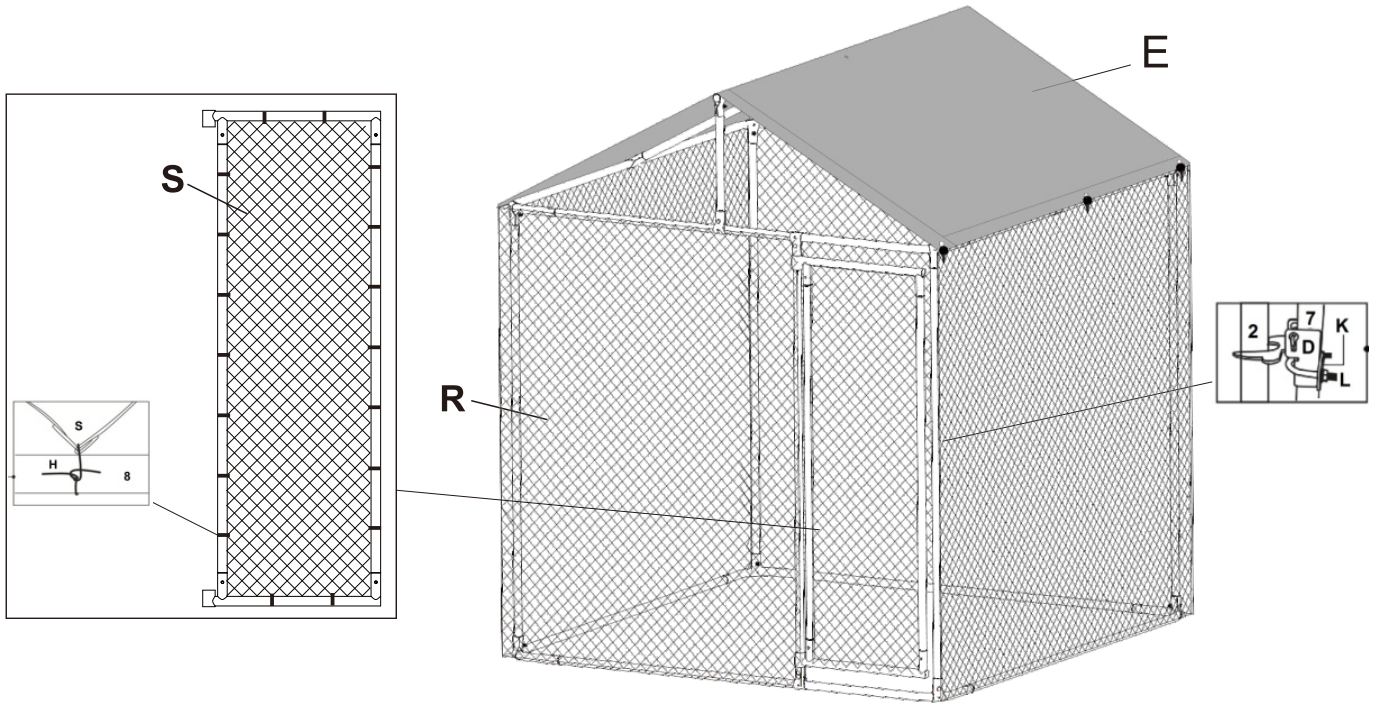



### Installing the chain link mesh

First start by unrolling the compressed chain-link mesh roll on the ground and extending it. Then check whether the mesh wires are misaligned and unhooked, and restore it. Next roll it again. And use ties(I) to fix one side of the mesh on the braided door frame. After that wrap the mesh around the dog kennel. During the process of enclosing, use ties (I) to fix the mesh up and down to prevent it from slipping. After that tighten the mesh and fix it to another doorframe pillar and remove the excess mesh. Finally reinforce and fix with steel wire(H).

#### Notice

1. Need 2 people at least when you assemble to avoid the damage of steel tube.
2. Do not use this cage unless all bolts, screws and knobs are firmly secured.
3. Please use it on a flat hard ground.
4. No climbing and no revision on product.
5. Caution, hands pinching.

#### Warning:

A: Guarantee every post upright

B: Fasten (C) with Rand electric tool in the right direction.

C: Make sure every (C) assembled correctly before put your kennel in use.

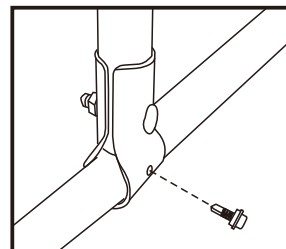

### Mise en place du grillage

Commencez par dérouler le rouleau de grillage comprimé sur le sol et étendez-le. Vérifiez ensuite si les fils de la maille sont mal alignés et décrochés, et rétablissez-les. Ensuite, dérouler à nouveau le rouleau. Utilisez des attaches (I) pour fixer un côté du grillage sur le cadre de la porte tressée. Enroulez ensuite le grillage autour de la niche. Pendant l'enroulement, utilisez des attaches (I) pour fixer le grillage de haut en bas afin d'éviter qu'il ne glisse. Serrez ensuite le grillage et fixez-le à un autre pilier du cadre de la porte, puis enlevez l'excédent de grillage. Enfin, renforcez et fixez le grillage avec du fil d'acier (H).

#### Remarques

1. 2 personnes au moins sont nécessaires lors de l'assemblage pour éviter d'endommager le tube d'acier.
2. n'utilisez pas cette cage si tous les boulons, vis et boutons ne sont pas fermement fixés.
3. veuillez l'utiliser sur un sol plat et dur.
4. ne pas grimper et ne pas réviser le produit.
5. attention, pincement des mains.

#### Avertissement :

A : Garantir chaque poteau en position verticale

B : Fixer (C) avec un outil électrique Rand dans la bonne direction.

C : Assurez-vous que chaque (C) est correctement assemblé avant de mettre votre chenil en service.

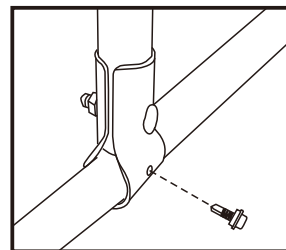

### Instalación de la malla metálica

En primer lugar, desenrolle el rollo de malla metálica comprimido en el suelo y extiéndalo. A continuación, compruebe si los alambres de la malla están desalineados y desenganchados, y restablézcalo. A continuación, vuelva a enrollarla. Y utilice bridas(I) para fijar un lado de la malla al marco trenzado de la puerta. Después, enrolle la malla alrededor de la caseta del perro. Durante el proceso de cerramiento, utilice bridas (I) para fijar la malla arriba y abajo para evitar que se deslice. Después, apriete la malla y fíjela a otro pilar del marco de la puerta y retire la malla sobrante. Finalmente reforzar y fijar con alambre de acero(H).

#### Nota

1. Se necesitan al menos 2 personas para el montaje para evitar daños en el tubo de acero.
2. No utilice esta jaula a menos que todos los pernos, tornillos y pomos estén firmemente asegurados.
3. Por favor, utilícela en un terreno plano y duro.
4. No escalar ni revisar el producto.
5. Precaución, pellizcar las manos.

#### 6.Warning:

A: Garantizar cada poste en posición vertical

B: Fije (C) con la herramienta eléctrica Rand en la dirección correcta.

C: Asegúrese de que cada (C) montado correctamente antes de poner su perrera en uso.

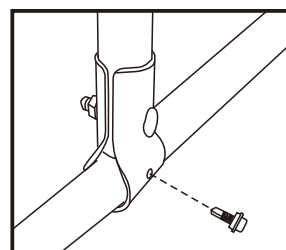

### Instalação da rede de elos de corrente

Em primeiro lugar, comece por desenrolar o rolo de rede de elos de corrente comprimido no chão e estendê-lo. Em seguida, verifique se os fios da rede estão desalinhados e desengatados e reponha-os. Em seguida, enrolar novamente. Utilizar laços (I) para fixar um dos lados da rede na estrutura entrançada da porta. Depois, enrole a rede à volta do canil. Durante o processo de enrolamento, utilizar os atilhos (I) para fixar a malha para cima e para baixo, para evitar que escorregue. Depois, aperte a rede e fixe-a noutra pilar do caixilho da porta e retire o excesso de rede. Por fim, reforçar e fixar com fio de aço (H).

#### Nota

1. é necessário ter pelo menos 2 pessoas na montagem para evitar danos no tubo de aço.
2. não utilizar esta gaiola sem que todos os parafusos e manípulos estejam bem fixos.
3. utilizar a gaiola num terreno plano e duro.
4. não trepar e não efetuar revisões no produto.
5. cuidado, as mãos estão a apertar.

#### Aviso:

A: Garanta que todos os postes estão na vertical

B: Fixar (C) com a ferramenta eléctrica Rand na direcção correcta.

C: Certifique-se de que todos os (C) estão corretamente montados antes de colocar o canil em funcionamento.

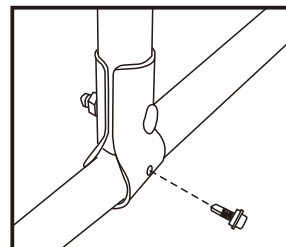

### Anbringen des Maschendrahts

Rollen Sie zunächst die komprimierte Maschendrahtrolle auf dem Boden aus und ziehen Sie sie auseinander. Überprüfen Sie dann, ob die Maschendrahte falsch ausgerichtet sind und sich gelöst haben, und bringen Sie sie wieder in Ordnung. Dann rollen Sie es erneut auf. Befestigen Sie eine Seite des Netzes mit Kabelbindern (I) an dem geflochtenen Türrahmen. Danach wickeln Sie das Netz um die Hundehütte. Während des Umschließens das Netz mit Bändern (I) oben und unten fixieren, damit es nicht verrutscht. Danach ziehen Sie das Netz fest und befestigen es an einem anderen Türrahmenpfeiler und entfernen das überschüssige Netz. Zum Schluss verstärken und befestigen Sie sie mit Stahldraht (H).

#### Hinweis

1. mindestens 2 Personen für den Zusammenbau benötigen, um eine Beschädigung des Stahlrohrs zu vermeiden.
2. benutzen Sie diesen Käfig nicht, wenn nicht alle Bolzen, Schrauben und Knöpfe fest angezogen sind.
3. bitte verwenden Sie ihn auf einem flachen, harten Boden.
4. kein Klettern und keine Revision am Produkt.
5. vorsicht, Hände einklemmen.

#### Warnung:

A: Stellen Sie sicher, dass jeder Pfosten aufrecht steht.

B: Befestigen Sie (C) mit Rand Elektrowerkzeug in der richtigen Richtung.

C: Vergewissern Sie sich, dass alle (C) korrekt montiert sind, bevor Sie den Zwinger in Betrieb nehmen.

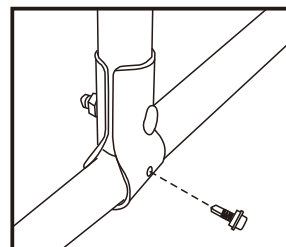

### Installazione della rete a maglia metallica

Per prima cosa srotolare il rotolo di rete a maglie compresso sul terreno e allungarlo. Quindi verificare se i fili della rete sono disallineati e sganciati e ripristinarli. Quindi arrotolarlo di nuovo. Con le fascette (I) fissare un lato della rete al telaio intrecciato della porta. Quindi avvolgere la rete intorno alla cuccia. Durante il processo di avvolgimento, utilizzare le fascette (I) per fissare la rete in alto e in basso per evitare che scivoli. Successivamente, stringere la rete e fissarla a un altro pilastro del telaio della porta e rimuovere la rete in eccesso. Infine, rinforzare e fissare con filo d'acciaio (H).

#### Avviso

1. È necessario che almeno 2 persone montino la gabbia per evitare di danneggiare il tubo d'acciaio.
2. Non utilizzare la gabbia se tutti i bulloni, le viti e le manopole non sono ben fissati.
3. Si prega di utilizzarla su un terreno piano e duro.
4. Non arrampicarsi e non fare revisioni sul prodotto.
5. Attenzione, mani che si pizzicano.

#### Avvertenze:

A: Garantire ogni montante in posizione verticale

B: Fissare (C) con l'utensile elettrico Rand nella giusta direzione.

C: Assicurarsi che ogni (C) sia montato correttamente prima di mettere in funzione la cuccia.

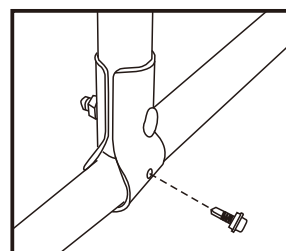

If you have any questions, please contact our customer care center.

Our contact details are below:

 001-877-644-9366

 customerservice@aosom.com

Imported by Aosom LLC

27150 SW Kinsman Rd Wilsonville, OR 97070 USA

MADE IN CHINA

**US**

Si tiene alguna pregunta, comuníquese con nuestro Centro de Atención al Cliente.

Nuestros datos de contacto son los siguientes:

 0034-931294512

 atencioncliente@aosom.es

IMPORTADOR:

SPANISH AOSOM, S.L.

C/ ROC GROS, Nº 15. 08550, ELS HOSTALETES DE BALENYÀ, SPAIN.

B66295775

WWW.AOSOM.ES

HECHO EN CHINA

**ES**

If you have any questions, please contact our customer care center.

Our contact details are below:

 416-792-6088

 customerservice@aosom.ca

Imported by Aosom Canada Inc.

7270 Woodbine Avenue, Unit 307, Markham,

Ontario Canada L3R 4B9

MADE IN CHINA

**CA**

Se tiver alguma dúvida, por favor contacte o nosso Centro de Atendimento ao Cliente.

Os nossos dados de contacto são os seguintes:

 0034-931294512 (SEG-SEX DAS 7:30H ÀS 16:30H)

 info@aosom.pt.

IMPORTADOR:

SPANISH AOSOM, S.L

C.ROC GROS N.15, 08550. ELS HOSTALETES DE BALENYÀ

WWW.AOSOM.PT

**PT**

Si vous avez la moindre question, veuillez contacter notre centre d'assistance à la clientèle.

Nos coordonnées sont les suivantes:

 416-792-6088

 customerservice@aosom.ca

Importé par Aosom Canada Inc.

7270 Woodbine Avenue, unité 307,

Markham, Ontario Canada L3R 4B9

Fabriqué en Chine

**DE**

Wenn Sie Fragen haben, wenden Sie sich bitte an unser Kundendienstzentrum.

Unsere Kontaktdaten stehen unten:

 0049-0(40)-88307530  service@aosom.de

ADRESSE DES IMPORTEURS:

MH Handel GmbH

Wendenstraße 309

D-20537 Hamburg

Germany

IN CHINA HERGESTELLT

**IT**

In caso di dubbio, si prega di contattare il nostro centro assistenza clienti.

I nostri dettagli di contatto sono di seguito:

 0039-0249471447  clienti@aosom.it

IMPORTATO DA:

AOSOM Italy srl

Centro Direzionale Milanofiori

Strada 1 Palazzo F1

20057 Assago (MI)

P.I.: 08567220960

FATTO IN CINA

**UK**

If you have any questions, please contact our customer care center.

Our contact details are below:

 0044-800-240-4004

 enquiries@mhstar.co.uk

IMPORTER ADDRESS:

MH STAR UK LTD

Unit 27, Perivale Park,

Horsenden lane South

Perivale, UB6 7RH

MADE IN CHINA

**FR**

Si vous avez la moindre question, veuillez contacter notre centre d'assistance à la clientèle.

Nos coordonnées sont les suivantes:  0033-1-84166106  aosom@mhfrance.fr

Importé par: MH France 2, rue Maurice Hartmann 92130 Issy-les-Moulineaux

Fabriqué en Chine

France



FR

**DONNEZ  
OU  
RECYCLEZ**



OU



OU



ASSOCIATION LIVRAISON DÉCHÈTERIE

Adresses sur [quefairedemesdechets.fr](http://quefairedemesdechets.fr)