

Please read the manual before using the product. The manual and carton contain important information, please keep them properly for later references. If failure to following the instruction in the manual, it might be dangerous for your child.

In order to improve the product and quality, we may change the parts of structure, appearance, packing method, assembly method and function of the product without any notice. When there is any difference between the manual and the product, please subject to the actual product. We are sorry for any inconvenience.



IN240300103V01_US

370-311V80

The assembly manual of
battery operated car

Executive standard:

EN71-1

EN71-2

EN71-3















EN62115

ASTM F963



 **WARNING:**

Products should be assembled by an adult. Protective equipment should be worn. Not to be used in traffic. Not suitable for children under 3 years. Choking hazard- small parts. In unassembled state, contains potentially hazardous small parts. Please keep out of the reach of small children. Pay attention to the potential hazards of using the toy in areas other than private grounds.

No	Parts Name	QTY	Pictures
①	Car body	1	
②	Backrest	1	
③	Seat	1	
④	Windshield	1	
⑤	Steering wheel	1	
⑥	Front wheel	2	
⑦	Rear wheel	2	
⑧	Wheel cover	4	
⑨	Mirror	2	
⑩	Steering axle	1	
⑪	Wrench	2	
⑫	Charger	1	
⑬	Remote control	1	
⑭	User manual	1	

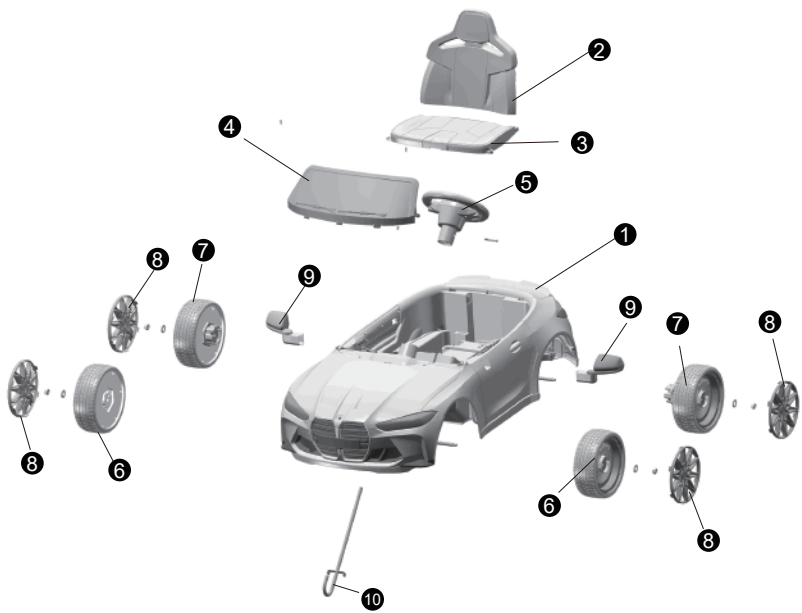

12



13

Tools:



Phillips
Screwdriver
(Not Included)



11

Disclaimer:

The pictures in this instruction are for assembly reference only.
Please refer to the actual product.

Warning:

This product is not the vehicle for transportation, it should be used under adult guidance. Parents should ensure that children have taken the safety measures before use.

The toy should be used with caution since skill is required to avoid falls or collisions causing injury to the user or third party.

PRODUCT SPECIFICATIONS

Battery	12V4.5AH
Main material	PP
Suitable age	37-95 months old
Weight limit	25kgs (55lbs)
Product size	108*69.5*51CM
Speed	3-5K/H
Runtime	45 minutes after charging 8-12 hours, based on ride on conditions
Charger	Input AC 100-240V Output DC 12V0.6A
Fuse	Auto-reset fuse

Assembly instruction

Car assembling should be done by the adults.

Take care of small parts. To avoid choking hazard, keep children away while assembling. Children under 36 months are prohibited to use.

Please count all the parts carefully before assembling and dispose the plastic bag properly. To avoid choking hazard, children are not allowed to play with the bag.

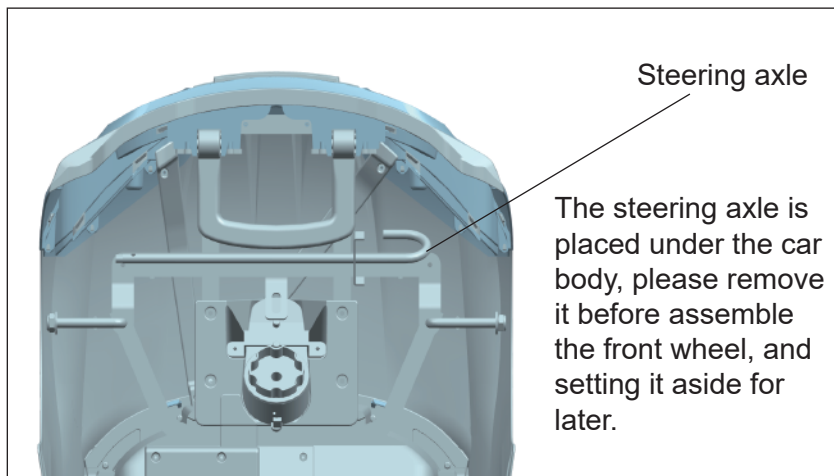

1. Front wheel assembly

There are two lock nuts, two 8mm washers and two 10mm washers on each side of front axle. Turn over the car body ①, use the wrench ⑪ to remove the lock nut from front axle, then remove two 8mm washers, keep them for later use. No need to remove two 10mm washers. Insert two front wheels ⑥ and two 8mm washers into front axle on each side, use the wrench ⑪ to fix them with the lock nuts. While applying pressure lock wheel covers ⑧ into grooves on front wheels ⑥.

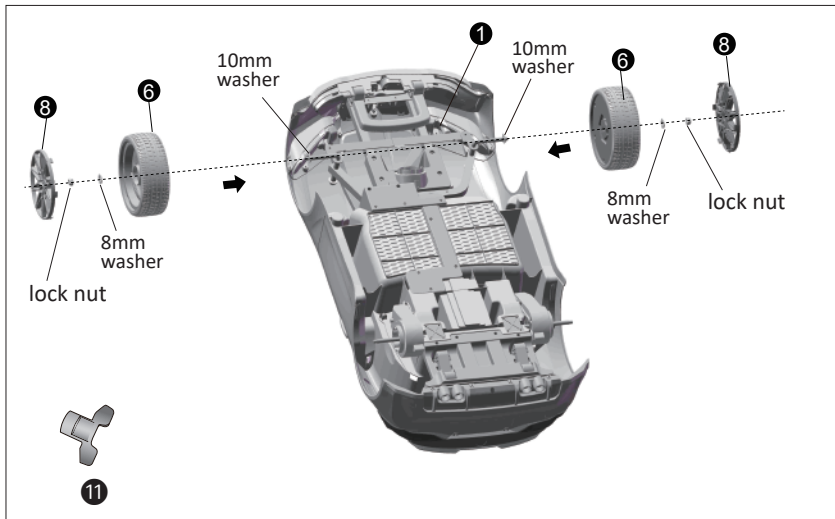

2.Rear wheel assembly

Use the wrench **11** to remove the lock nus from rear axle, then remove two 8mm washers, keep them for later use. Insert two rear wheels **7** and two 8mm washers into rear axle on each side, use the wrench **11** to fix them with the nuts. While applying pressure lock wheel covers **8** into grooves on rear wheels **7**.

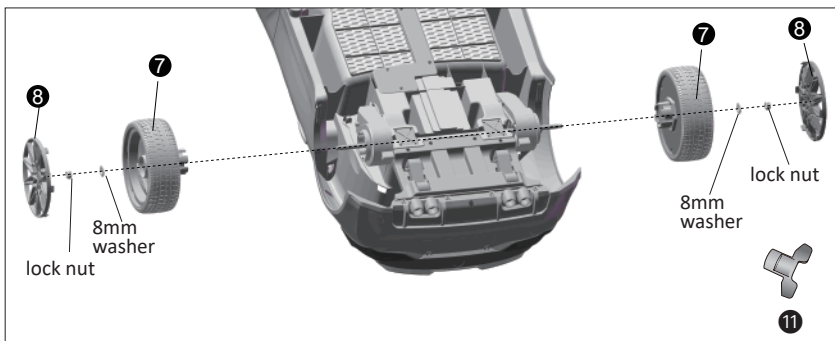

3. Mirror assembly

Insert two mirrors ⑨ into corresponding position on car body, push them into place.

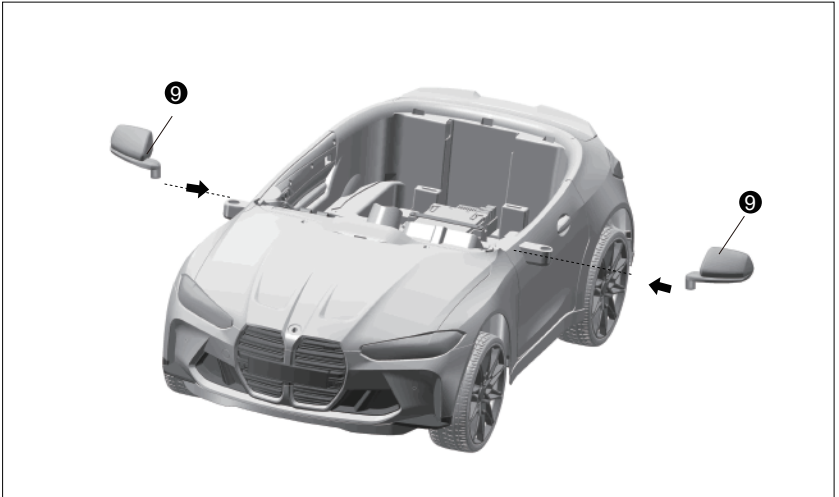

4. Steering axle assembly

A. Insert the steering axle ⑩ into car body, make sure the hook on steering axle ⑩ pass through the hole on front axle as shown in picture (a).

B. Use a screwdriver to remove the screw and the lock nut from steering wheel ⑤, keep them for later use. Connect steering wheel cable with the cable coming out of the steering column and match the connectors. Align steering wheel ⑤ with steering axle ⑩, match the holes on steering wheel ⑤ and the holes on steering axle ⑩, use a screwdriver to fix them with the screw and the nut.

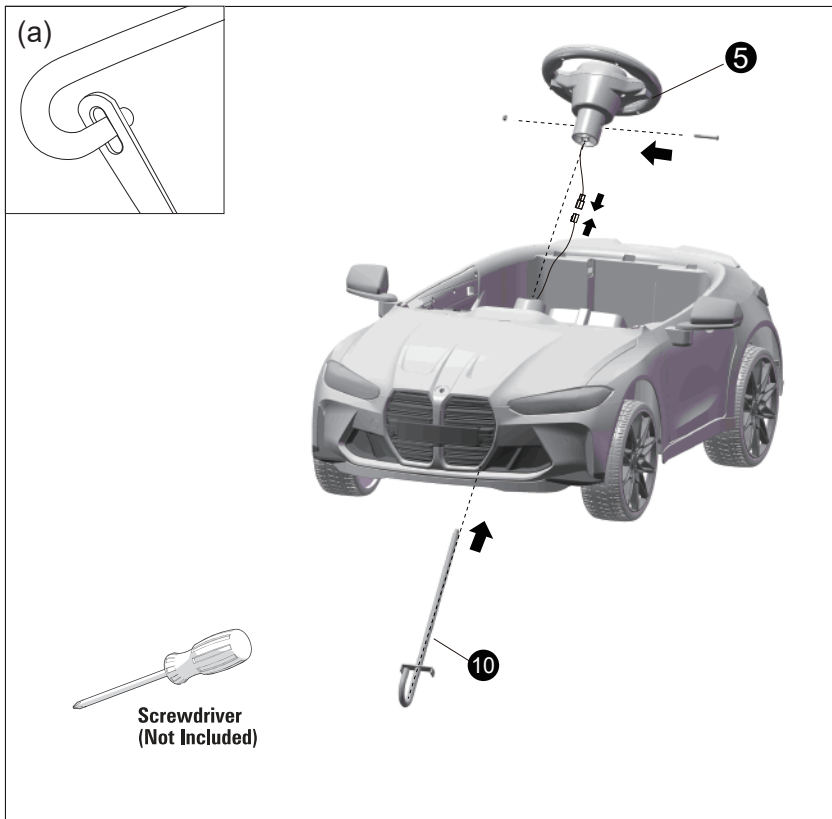

5. Windshield assembly

Using the screwdriver, remove two M4*16 screws from the car body, setting them aside for later. Insert the windshield ④ into corresponding position on car body, push it into place, tighten two M4*16 screws using the screwdriver.

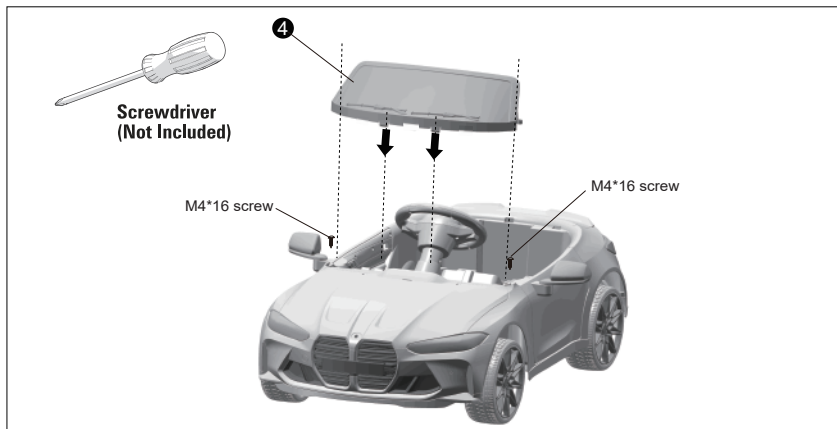

6. Battery connection

Match two red plugs to connect the power.

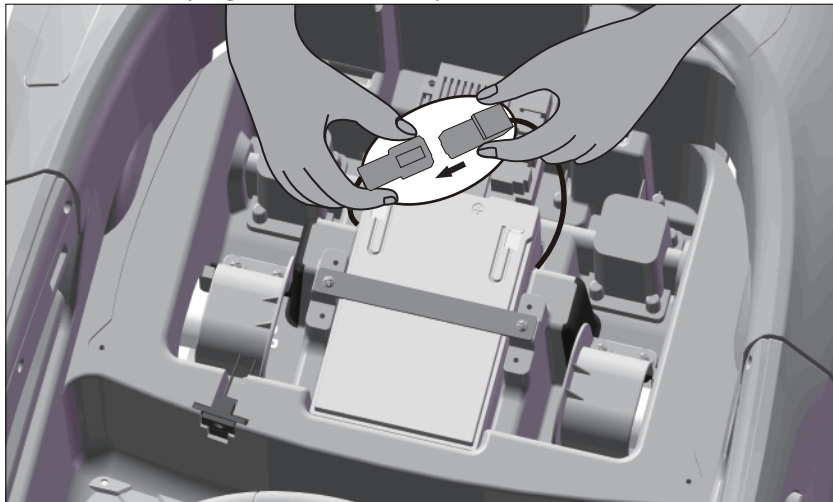

7. Seat assembly

There are two M4*16 screws on the seat. Insert backrest **2** into corresponding position on car body, attach the seat **3** with car body, tighten two M4*16 screws using the screwdriver.

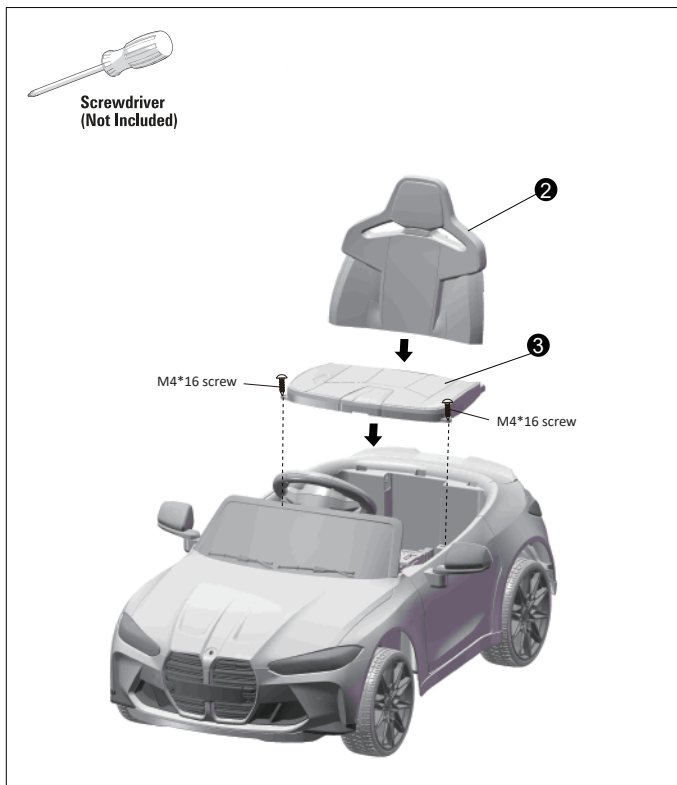

SECURITY WARNING

- 1.The installation and charging of vehicle should be under adult supervision at all times.
- 2.This product is limited to the children from 37-95 months old, 25kgs (55lbs) weight limit.
- 3.This product is ideal for driving on a hard flat surface.
- 4.It is strictly prohibited in the streets or the road, pot holes, and slopes.
- 5.Avoid driving in the sand or grass or uneven ground.
- 6.Children should be given full instructions on operation of the car. Improper operation can cause damage or accidents.

7. While children are driving, it is parents' duty to supervise at all time to avoid accidents.
8. Avoid driving in rains or flooded pathways. By doing so it can damage the motor, circuit and other electrical equipments.
9. Battery charger should be regularly inspected by parents to insure that the wires, plugs, crusts and other components are not damaged. Please stop using if any damage is found, until it is completely restored.
10. In order to ensure product life and safety, avoid damage to the charger, battery or electric circuit, the car must use the default configuration of a dedicated charger and power supply.
11. Rechargeable batteries should be removed from the toy before charging.
12. When no use of product, please cut off the product power, and keep all the switch to "stop" or "off" position.
13. The charger provided is not a toy. It is to be kept away from children.
14. Strictly prohibit using the non-manufacturer provided parts.

USAGE DIRECTION

1. Before using it, make sure that all the following works are done.
 - Step described in accordance with the instructions to complete the installation of the car, the battery plug-in has been connected, the power supply has been switched on.
 - Make sure that all the positions which need the screws are fixed tightly.
 - Parents or guardian should ensure that children have taken the safety measures before using.
- To reduce the risk during using, pay attention the followings:
When driving the car, child should sit on the car seat.
Adult or parents should take more care and guidance when child driving and can't leave away.
Pay attention to the driving environment and driving on the hard flat surface, not the unsafe environment.

For example:

- a. The trenches, the riverside, slope or uneven ground;
- b. Road or other places for driving and walking;
- c. The obstruction which is easily hitting and causing injury;
- d. Other unsafe zones.

To avoid accident, please use only in daytime or bright place, avoid using under low visibility.

FUSE

This car has a auto-reset fuse, if the car stops suddenly during driving, it is mainly caused by instantaneous current exceeds ,which makes the fuse to trip. Then just stop operating for about 8 seconds, and this fuse can be reset. Then turn on the power switch again. In order to avoid the fuse tripping and cutting off power supply, please pay attention to the following matters.

This product can't be overloaded, the maximum load is 25kgs (55lbs).

Don't drag anything behind the product.

Don't let the water or other liquid into the batteries and other electrical components.

Don't change the circuit system and structure of the product.

2. Operating(function reference diagram)

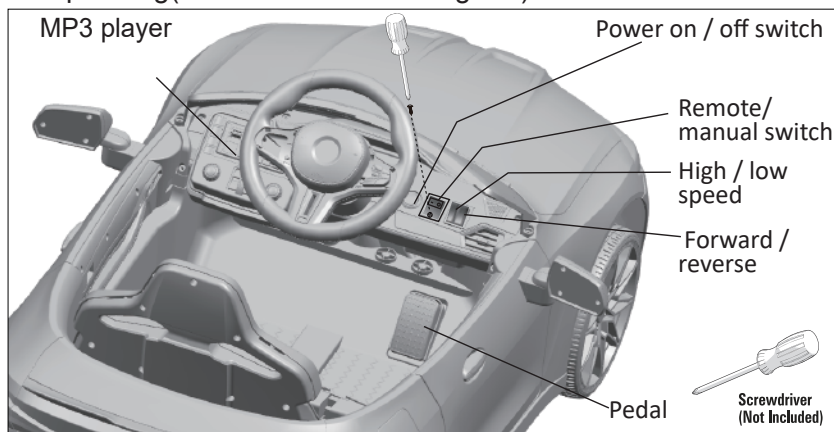

Remote / manual switch instruction:

There is a screw on the cover of Remote / manual switch, using a screwdriver, remove the screw and open the cover.

This switch can achieve remote or manual function. Turn the switch on “I” position, remote control function can be used, and the car can be operated by the remote control only, the pedal can not be used. Turn the switch on “O” position, manual function can be used, and the car can be operated by the pedal only, the remote control can not be used. Always operate this switch by the adult.

MP3 Player

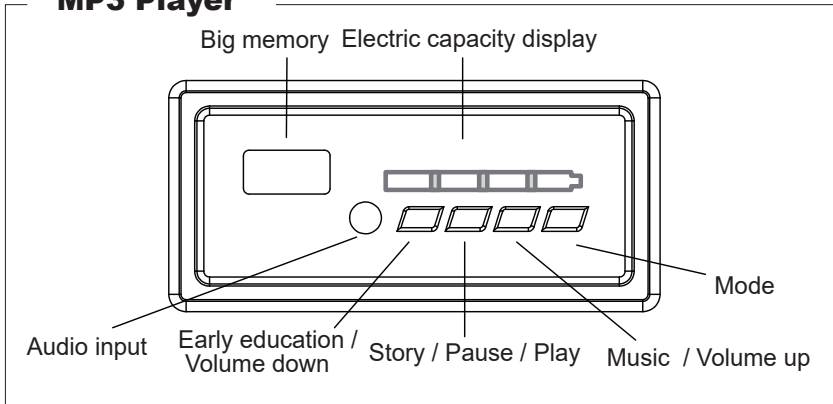

Remote control instruction

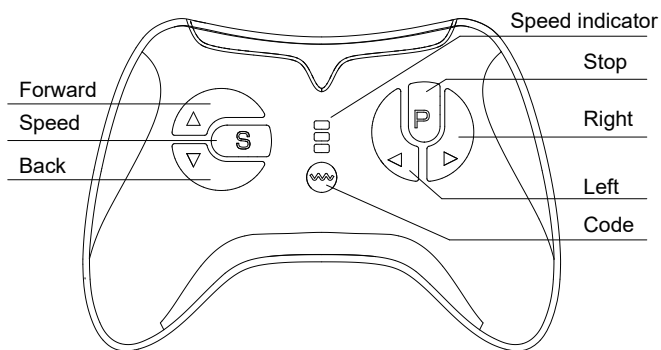

2.4G Remoter Control Instructions

For the first time need to code, this product has a memory function, replacement battery next time, you do not need to match the code Once again.

①. Long press "M" button more than three seconds, until the first LED lights flashing.

②. Open body power, first a long bright LED turns on the success of the code.

③. Remote control 10 seconds without operating automatic standby, press any key to wake up.

④. Key Description: "△" Forward, "▽" Back, "◁" Left, "▷" Right, "S" Speed, "P" Stop.

Press the "S" key to set the speed, a light is low, two lights for medium-speed, three lights for high-speed, the car back with only medium-speed

Press the "P" key to keep the brakes, the indicator full flash, press the brake button again to lift the brake.

WARNING:

1. When operating the car, the distance between the car which kid sit in and the remote control which operated by adults should not be more than 10 meters.
2. The remote is only for adults to use, keep far away from child.
3. Before using the remote, please read the instruction manual carefully, and operate the empty car first, only when knowing the way of operation, you can use the remote with kid in the car.
4. This product should not be used on traffic road and the place with water and obstacles.
5. To Avoid damaging the circuit, please keep the remote control from wet and in rains.
6. Don't mix old and new batteries and different brands of dry batteries.

7. In order to avoid damaging the remote control, please take out the batteries if not use the remote control for a long time to avoid battery leakage and circuit corrosion.
8. Avoid dropping the remote control during using.
9. Install batteries with right polarity to avoid battery short circuit.
10. Charging must be done by adults. Non rechargeable batteries can't be charged.
11. Exhausted battery should be removed from the toy properly and prevent children from playing.
12. Take out the battery if no use for long time, properly handle the battery, and prevent children from playing.
13. If the remote distance is less than 3 meters, the battery in the remote control maybe has run out of power , please change 2 pieces of AAA alkaline batteries.

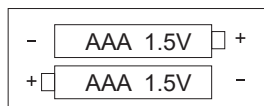

How to insert batteries: Use screwdriver to loosen the screw on the back of the remote control, open the battery cover, and install two AAA 1.5V alkaline type batteries according to the diagram (Batteries are self-provided), then close the battery cover, and fix with screw.

CHARGING WAY

- For Safety purpose ,the charging must be done by adults.
 - Before first using, please connect two red plugs under the seat, use it only after charging 8-12 hours.
 - Charging socket is locate near the seat, please follow the instructions to charge the battery.
 - If the car has slowed down, it needs to be charged by 8-12 hours, maximum 20 hours.
- 1.First insert the plug of the charger into the charging port. (The car can not be used.)
 - 2.Then insert the charger to the power socket.

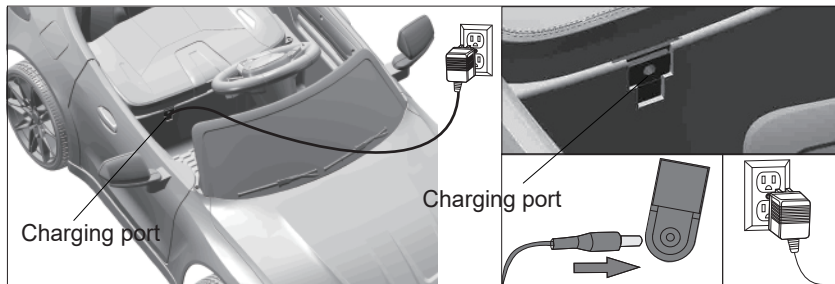

WARNING:

1 The toy is to be assembled by an adult. In unassembled state, it contains potentially hazardous sharp points & small parts, so please keep out of baby's reach.

2 CHOCING HAZARD – Small parts.

3 Not for children under 3 yrs.

4 Always wear shoes.

5 RISK OF FIRE. Do not bypass. Replace only with circuit protection device.

6 Protective equipment should be worn. Not to be used in traffic.

Attention:

- Can only use the charger and battery according to manufacturers regulations.

- Do not mix old and new or different types of batteries.

- The battery terminal should not be short circuit.

- Do not open the battery or charger.

- Do not reverse the battery.

- Before charging, please check whether the charger, battery and plug are ok, if you find any broken parts, you must stop using it immediately. And do not use it until it is fully repaired.

·The battery will be little warm when being charged, it is normal. If not, it may be caused from the short circuit of charger or circuit board.

·Must use the pressing plate to fix the battery.

·Run out of battery must be handled by adults, remove the battery which has run out from toys to recycle properly and shall not be arbitrarily discard.

·If the product is going to be stored unused long time , it must be fully charged, and charge it every 3 months ,so as to make sure the battery life.

·Charger and Battery are not toys. Keep them away from children.

MAINTENANCE AND SERVICE

1, Before use, parents should check whether all parts like batteries, charger, wires, plug, outer body and other parts are in good condition, check whether the screws are loose and whether there are potential safety hazards. Any damaged parts founded should be repaired before using.

2, After using the product for a period of time, use a small amount of lubricating oil to the moving parts to prevent wear and tear of rust.

3, Keep the car away from fire and direct sunlight. Place it stably, not upside down. The car shall be stored indoors or outdoors under cover.

4, The car should be kept away from hot items, such as stoves or heaters, or the plastic parts will melt. When charging, the car should be kept away from inflammable materials to prevent it from catching fire.

5, Charge in time after use. Charging should be done by adults. If the product is going to be unused for a long time, it must be fully charged. Charge it every month so as to extend the battery lifespan.

6, A soft cloth must be used to clean the car. Do not use chemical solvents to clean the plastic parts. Do not use soap or water to clean the car. Driving in rainy or snowy weather, water can damage the motor, battery and circuit system.

- 7, When stopping or storing the car, please cut off the power and make sure all switches are in the 'STOP' or 'OFF' position.
- 8, Do not use fuses different from the specifications of this product.
- 9, Do not change the product structure and circuit system. Maintenance and repair work must be done under the guidance of the professional or technical personnel in place.
- 10, Do not use the product for other purposes. Put the battery in the right polarity.
- 11, Battery negative short circuit is prohibited. Non-rechargeable batteries cannot be charged.
- 12, Rechargeable batteries can only be charged under the supervision of the adult.
- 13, Do not mix old and new batteries or different types of batteries.
- 14, The battery running out of power should be removed from the car properly and not allowed to be played by children.
- 15, Disconnect the batteries completely when not in use and do not allow children to play with them.

TROUBLESHOOTING

Car does not move or power on	If "power" switch is in OFF position
	If the fuse is not functioning properly
	If the battery is not connected, check the red and black wires.
	If the charger is plugged in, car will not power on. Unplug charger.
	If the pedal switch is not functioning properly
	If the wheels stuck and cannot move
Car moves slowly	If the battery is not fully charged. Need to be charged in time
	If there is an issue with the wheels
	If rider weight exceeds specifications
Battery does not charge	If the charger is malfunctioning
	If the battery lost its capacity
	If the charger and battery connection are charged

WARNING:

This toy contains batteries that are non-replaceable.
A recommendation for adult supervision of young children.

WARNING:

To reduce risk of injury, adult supervision is required.
Never use in roadways, near motor vehicles, on or near steep
inclines of steps, swimming pools or other bodies of water,
always wear shoes, and never allow more 1 rider.
Only use the specified by the manufacturer battery.
Only use the charger specified by the manufacturer.



WARNING:

Assembly by an adult

Maximum capacity: 25kgs (55lbs)

- This toy contains batteries that are non-replaceable.
- Rechargeable batteries are only to be charged by adult.
- Instructions to be given to the child in the proper use of the toy, particularly in the use of any braking system
- A reminder that the toy should be used with caution since skill is required avoid falls or collisions causing injury to the user or third parties.
- Battery is only to be charged by person of at least 8 years old.
- Exhausted batteries are to be removed from the toy.

If you have any questions, please contact our customer care center.
Our contact details are below:



001-877-644-9366



customerservice@aosom.com

Imported by Aosom LLC
27150 SW Kinsman Rd Wilsonville, OR 97070 USA
MADE IN CHINA