

SPORTNOW

IN240300201V01_UK

A90-366V00

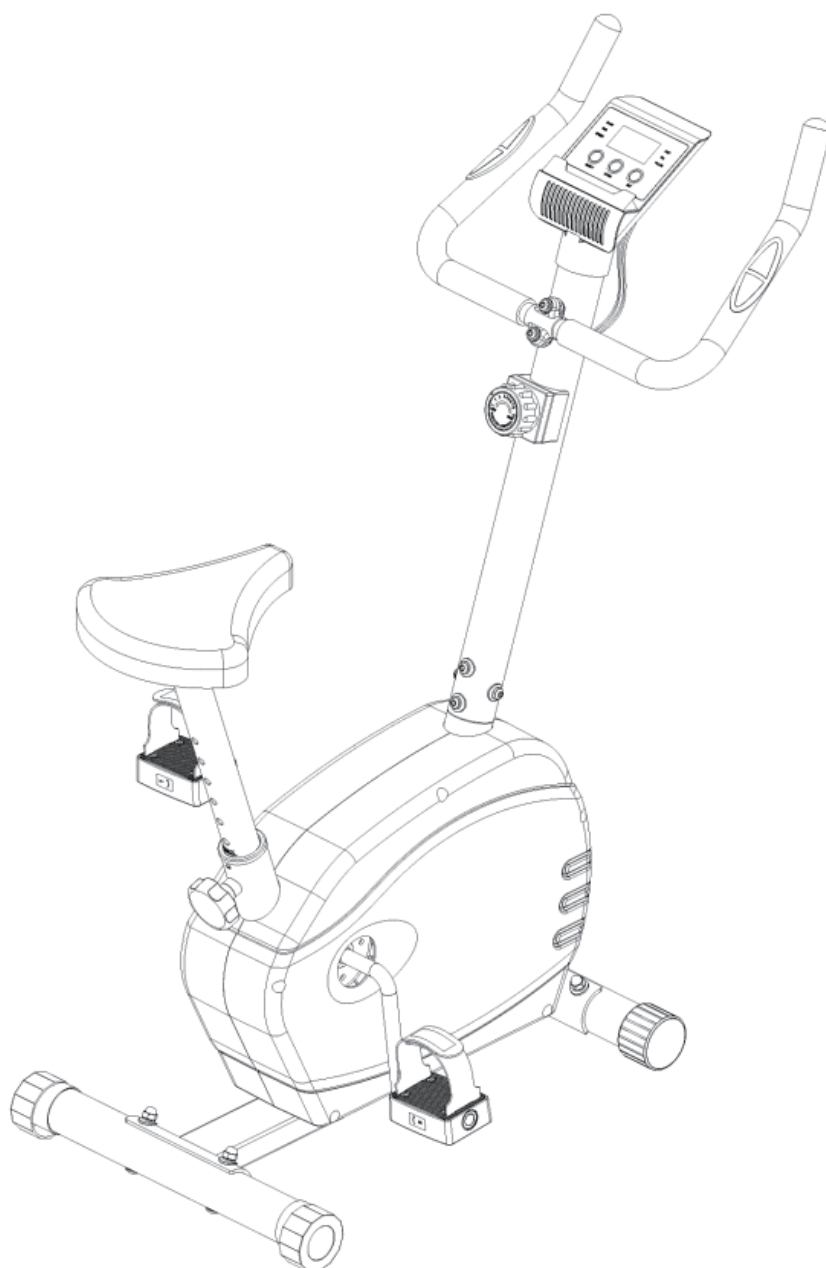

IMPORTANT, RETAIN FOR FUTURE REFERENCE: READ CAREFULLY

ASSEMBLY INSTRUCTIONS

Before Using!

1. Assembly this product properly using original parts according to the installation instruction. Before assembly, inspect whether packages are in good condition and whether spare parts are complete in accordance with transport precautions and the list of spare parts.
2. Prior to exercise, make sure equipment fasteners are in locking state.
3. Please place the exercise bike on a dry and flat ground.
4. To prevent the bottom of the equipment from damage such as abrasion and stain, put under the bottom an object such as a rubber cushion or a thin wood plate.
5. When starting the exercise, be sure to have no any object within 2m from the exercise bike.
6. Please use the attached or other appropriate tools to assemble or repair the exercise bike. After exercise, please wipe sweat off it.
7. Improper use and excessive exercise endanger your health. Please carry out your exercise plan under the direction of a doctor. He can provide you with excellent suggestions on your exercise gestures, exercise goals and your food. Never make exercise after a meal. This exercise bike is not for the medical purpose.
8. This product is used in home, please do not apply to commercial use, so as to avoid injury or cause accident.
9. Please use the exercise bike when the equipment is in good operation. Make necessary maintenance using original spare parts.
10. Do not modify or modify the product yourself to avoid any abnormality or accident.
11. When regulating the equipment, note to observe the best position and largest adjustable position to ensure the adjusted position is safe.
12. Unless otherwise specified in the instruction, this exercise bike is only for use by one person at one time.
13. During exercise, please wear sports cloths and shoes. The clothes shall not be too long and too wide so as to prevent them from being hooked or hung during exercise. The shoes must be suited for the feet and the soles shall be anti-slip.
14. Exercise should be stopped if any of the following occur: Nausea, Trembling, Extreme Shortness of Breath, Excessively Fast Heart Rate, A Throbbing Head or Pains in the Chest. Your physician should be consulted if any of the symptoms of discomfort persist.
15. Please the sport equipment are not toys for playing with, and thus, shall be used by those people for exercise purpose.
16. Children and disabled persons shall use the equipment in the presence of adults or healthy people. Appropriate measures shall be taken to ensure a child is unable to use the equipment without the supervision of an adult.
17. Make sure any part of another person will not be accessible to the equipment during the exercise.
18. To protect the environment, never discard packages or batteries, and please put them into a designated dustbin or other waste collection point.
19. The exercise bike has a maximum load of **120 KG**.

Attention!

- 1.If the computer would not be displaying data normally, please install the battery again.
- 2.The battery must be taken out from the computer for safe treatment once it was out of energy for trash.
- 3.This manual is also suitable for equipment without computer.

MAINTAIN

Neutral detergent can be used to dilute the water to wipe the cloth carefully wipe the oil, and then dry with a dry cloth.

Do not use alkaline solvents, solvents such as solvent,volatile oils and other solvents.

MAINTENANCE / INSPECTION

Avoid high temperature, moisture or direct sunlight, please place in a well-ventilated place.

When not in use please fold the admission, and placed in the children can not touch the Department.

If you do not use it for a while, be sure to check the precautions before using this product and use it for normal use.

When you accidentally wet the product, use a dry cloth to avoid skidding.

In case of malfunction, abnormality or any operational problem, please contact us at the company.

PRODUCT RECYCLING

Due to the different national recycling regulations, please refer to the relevant regulations.

Product exploded view

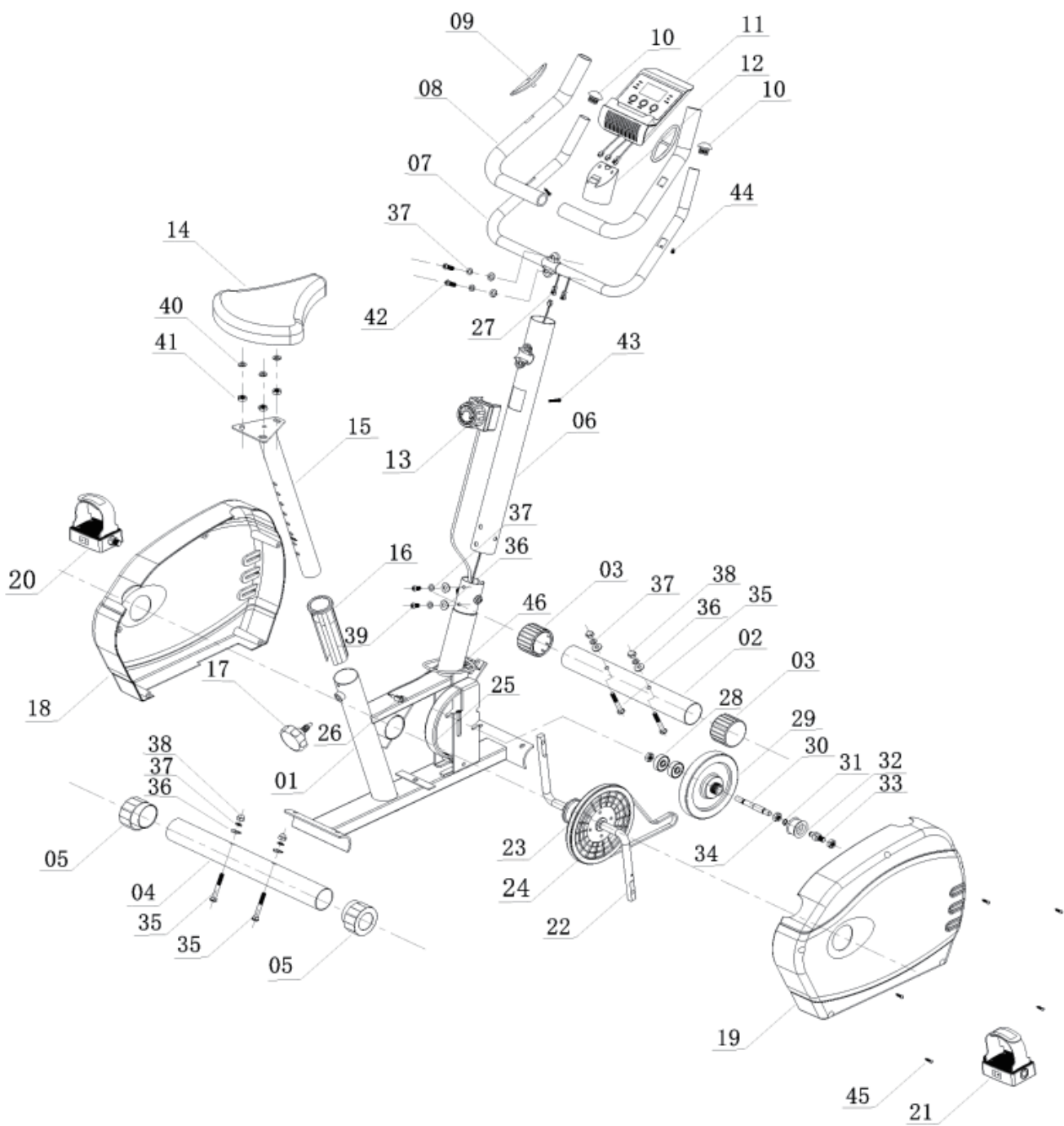

Product list

| NO. | PARTS | QTY | NO. | PARTS | QTY |
|-----|---|-----|-----|---------------------|-----|
| 01 | Main frame | 1 | 31 | Circlip | 1 |
| 02 | Front leg | 1 | 32 | Pinch roller | 1 |
| 03 | Forefoot tube plug | 2 | 33 | Pinch roller shaft | 1 |
| 04 | Rear leg | 1 | 34 | M10Nut | 3 |
| 05 | Rear leg pipe plug | 2 | 35 | M8-60 Carriage bolt | 4 |
| 06 | Handrail fixed pipe | 1 | 36 | D8 arc gasket | 8 |
| 07 | Armrest | 1 | 37 | D8 spring washer | 10 |
| 08 | Armrest foam | 2 | 38 | M8 cap nut | 4 |
| 09 | Armrest hand holding heart rate | 2 | 39 | M8-16 bolt | 4 |
| 10 | Handrail pipe pipe plug | 2 | 40 | D8 gasket | 3 |
| 11 | digital watch | 1 | 41 | M8 lock nut | 3 |
| 12 | Electronic watch installation plastic parts | 1 | 42 | M8-30 bolt | 2 |
| 13 | Resistance adjustment knob | 1 | 43 | M5-50 bolt | 1 |
| 14 | Cushion | 1 | 44 | M4-15 bolt | 2 |
| 15 | Post intubation | 1 | 45 | M4-25 bolt | 5 |
| 16 | After intubation tube plug | 1 | 46 | M6-40 bolt | 1 |
| 17 | Rear intubation adjustment knob | 1 | | | |
| 18 | Left chain cover | 1 | | | |
| 19 | Right chain cover | 1 | | | |
| 20 | Left pedal | 1 | | | |
| 21 | Right pedal | 1 | | | |
| 22 | Complete crank assembly | 1 | | | |
| 23 | Belt | 1 | | | |
| 24 | Belt pulley | 1 | | | |
| 25 | Resistance magnet assembly | 1 | | | |
| 26 | Induction line 01 | 1 | | | |
| 27 | Induction line 02 | 2 | | | |
| 28 | Bearing | 2 | | | |
| 29 | Flywheel | 1 | | | |
| 30 | Flywheel shaft | 1 | | | |

Product parameters Features Guidelines

Product parameter

| Length | Width | Height | Net weight | Gross weight | Load bearing |
|--------|-------|--------|------------|--------------|--------------|
| 910mm | 450mm | 1060mm | 15.5Kg | 16.5Kg | 100Kg |

Product Features

1. Two-way internal magnetic control flywheel.
2. Eight-speed resistance adjustment system.
3. Smooth and noise-free multi-slot belt transmission.
4. Multifunctional electronic watch displays speed, distance, heart rate, time and calories.
5. Front leg tube equipped with plastic rollers for easy movement.

USER'S GUIDE

1. After following the installation instructions, if you notice the three legs are not flat, you can adjust the pipe plugs on both sides of the rear leg until all three legs are level.
2. If your hand and feet position are not comfortable during exercise, adjust the height of the post-intubation tube according to your own height. When the intubation tube reaches the limit mark 'MAX', it cannot be raised any further. After adjusting the position, ensure the knob is inserted into the hole and locked securely.
3. When exercising, it is important to control the speed and rhythm of your exercise to avoid excessive strain on your body.

Additional information:

1. If you notice any slipping or loosening of the flywheel, stop training immediately. Do not continue using the product until the issue is resolved.
2. To increase the resistance level, adjust it in the direction indicated by the resistance adjustment knob.
3. This product is for adult use only. Keep small children away.
4. Before beginning your workout, make sure you fasten the straps on the pedals. This will prevent any accidental movement. Adjust the tightness of the straps according to your preference.

Product assembly wizard

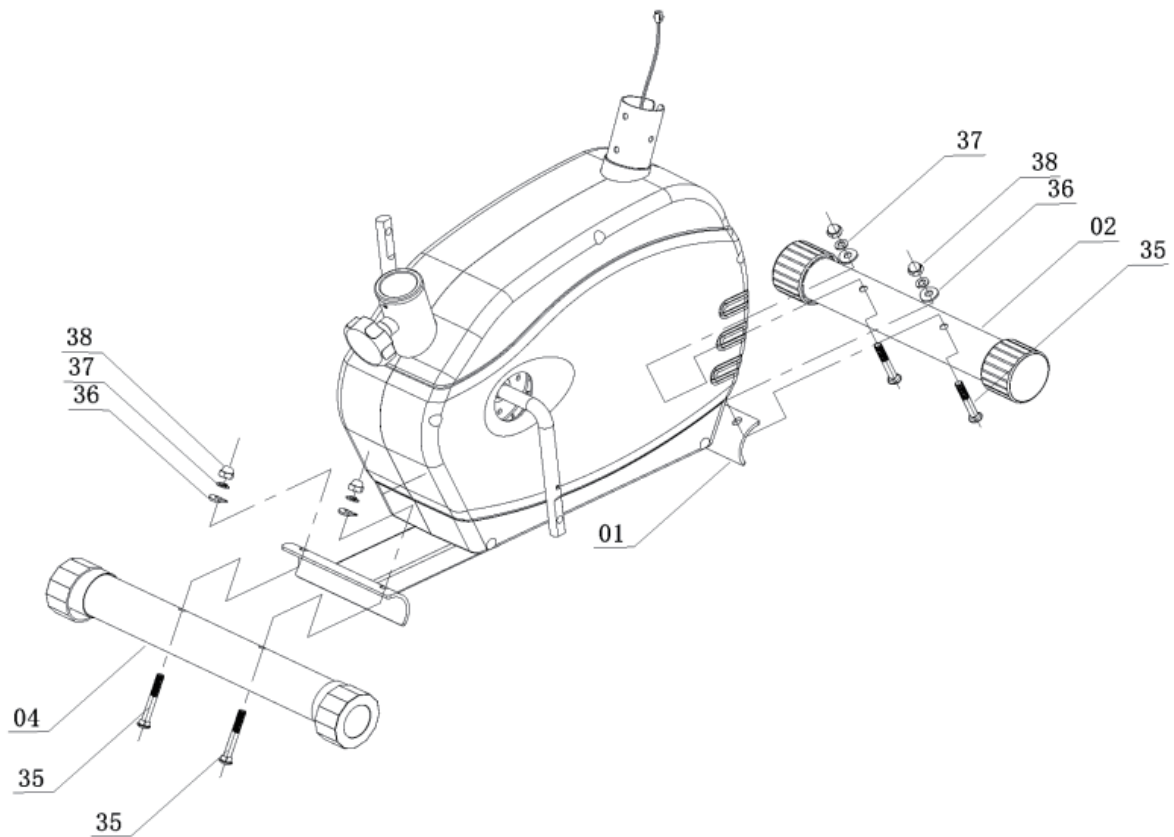

Step 1

Assembling the front leg tube:

- Insert the two M8-60 carriage bolts (35) into the square holes of the front leg tube (02), as shown in the diagram.
- Pass the screws through the holes of the main frame (01) bottom plate.
- Place the arc gasket (36) onto the screws, followed by the spring washer (37).
- Add the M8 cap nut (38) onto the screws.
- Use an open-end wrench to tighten the cap nut securely.

After the front leg tube is fully installed, proceed to install the rear leg tube (04), following the same method as described above.

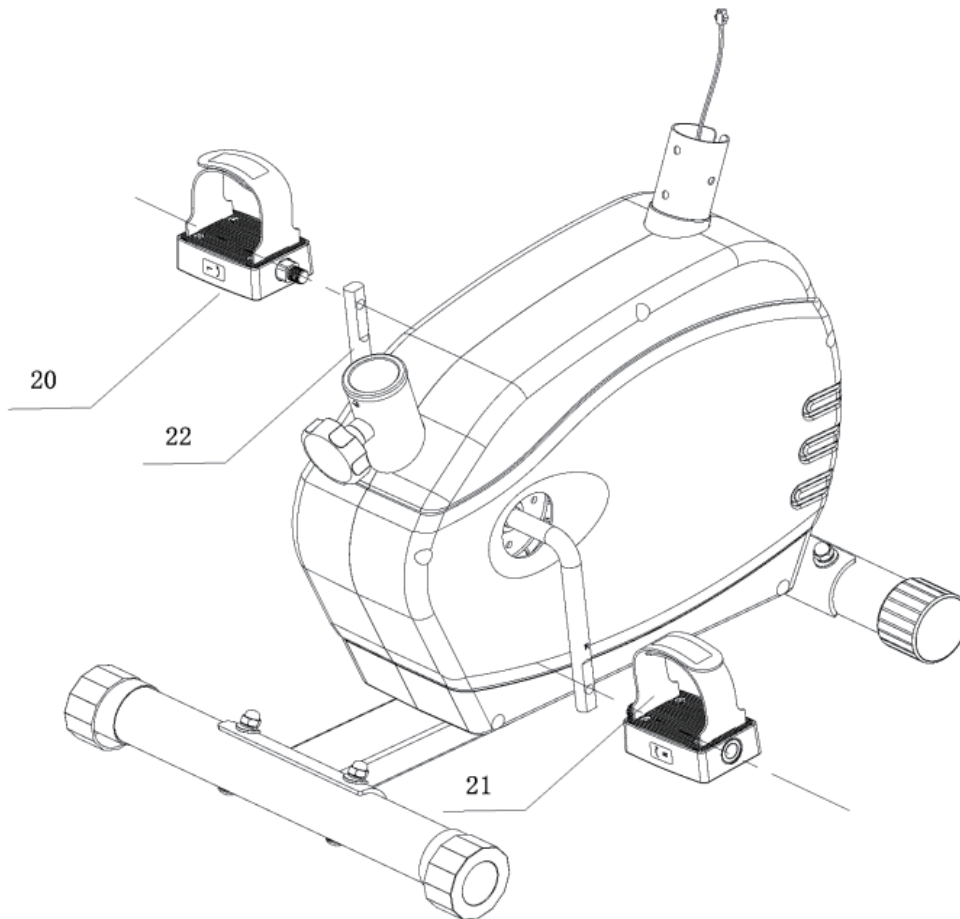

Step 2

Attaching the pedals to the crank assembly:

-Prepare the left pedal (20) and the right pedal (21).

-Align the left pedal with the left side of the crank assembly (22), then manually screw in about 4-5 turns.

-Repeat this process for the right pedal on the right side of the crank assembly.

-Once both pedals are partially screwed in, use a wrench to tighten them securely.

NOTE: Ensure you match the pedal with the correct side of the crank assembly, checking the marking indicated on the pedal. Do not rotate the pedals backwards, as it can damage the thread.

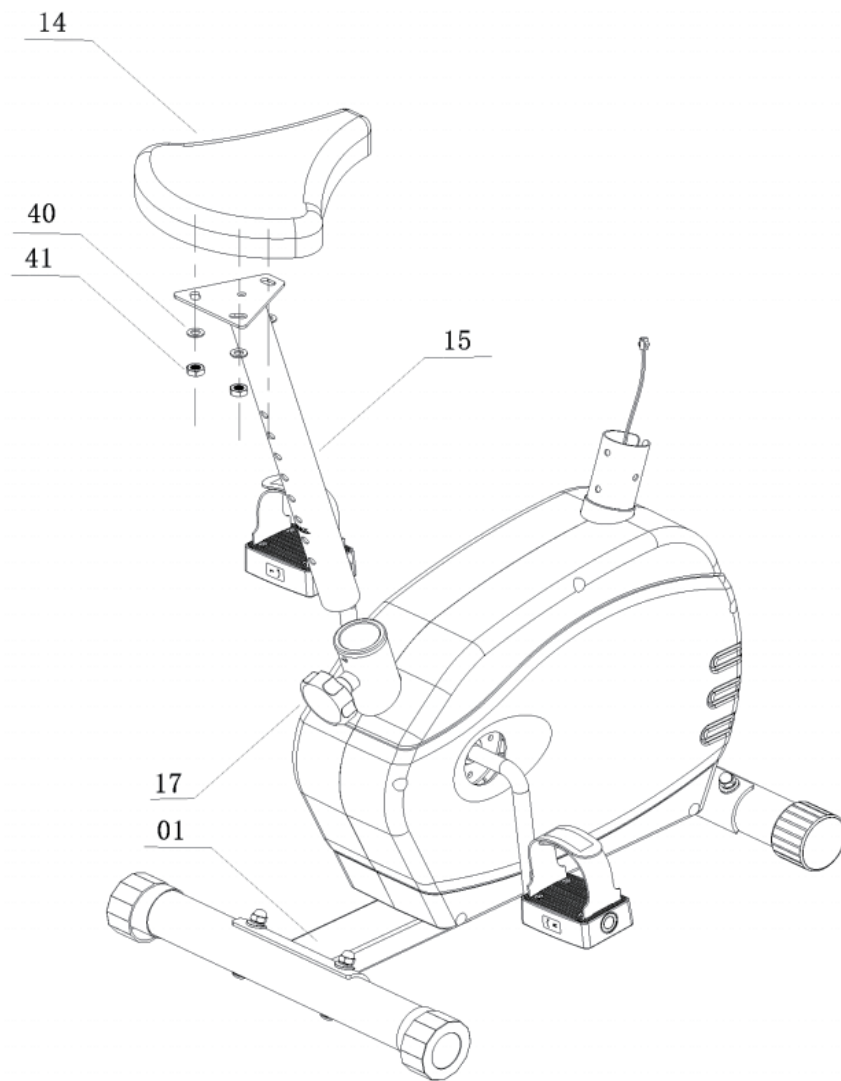

Step 3

Adjusting and securing the rear intubation:

- Rotate the rear intubation adjusting knob (17) outward, as shown in the figure.
- Insert the rear intubation (15) into the intubation hole of the main frame (01).
- Adjust the position of the rear intubation and secure it by tightening the rear intubation adjusting knob.
- Place the seat cushion (14) on the upper plate of the rear intubation tube.
- Tighten it in place using the D8 gasket (40) and the M8 lock nut (41).

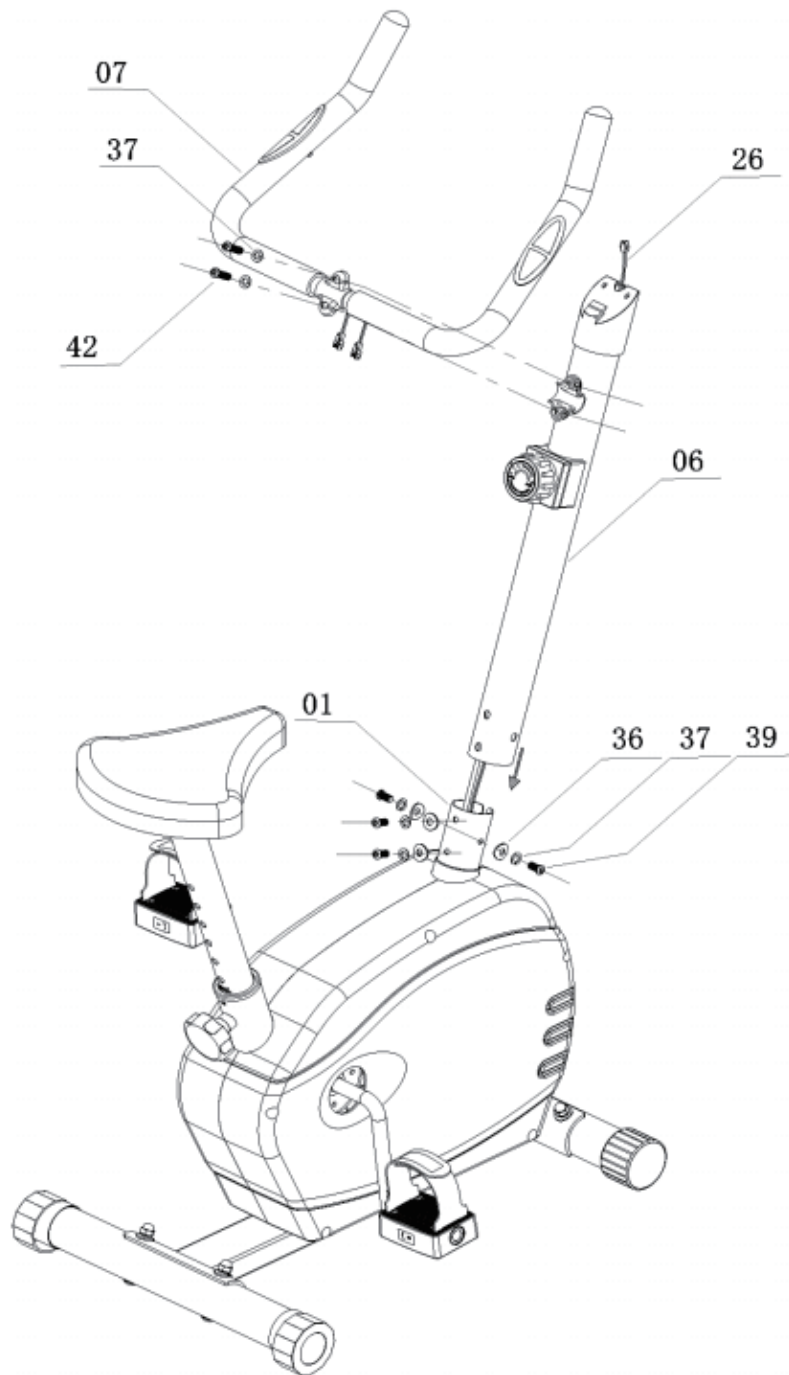

Step 4

Assembling and fixing the armrest securely:

- Pass the induction line (01) through the hole of the armrest fixing tube (06), then tie it with a cable to prevent it from slipping off.
- Insert the armrest fixing tube into the shrink tube at the front end of the main frame (01), Align the orientation and hole position. Place the arc gasket (36), spring gasket (37) and M8-16 bolt (39) in position. Tighten the bolts using an open-end wrench. Repeat this process for a total of four groups.
- Pass the M8-30 bolt (42) through the hole of the D8 spring washer (37). Place the armrest (07) on the armrest fixing tube, aligning the holes. Attach the M8-30 bolt assembly by hand and tighten it securely with an open-end wrench.

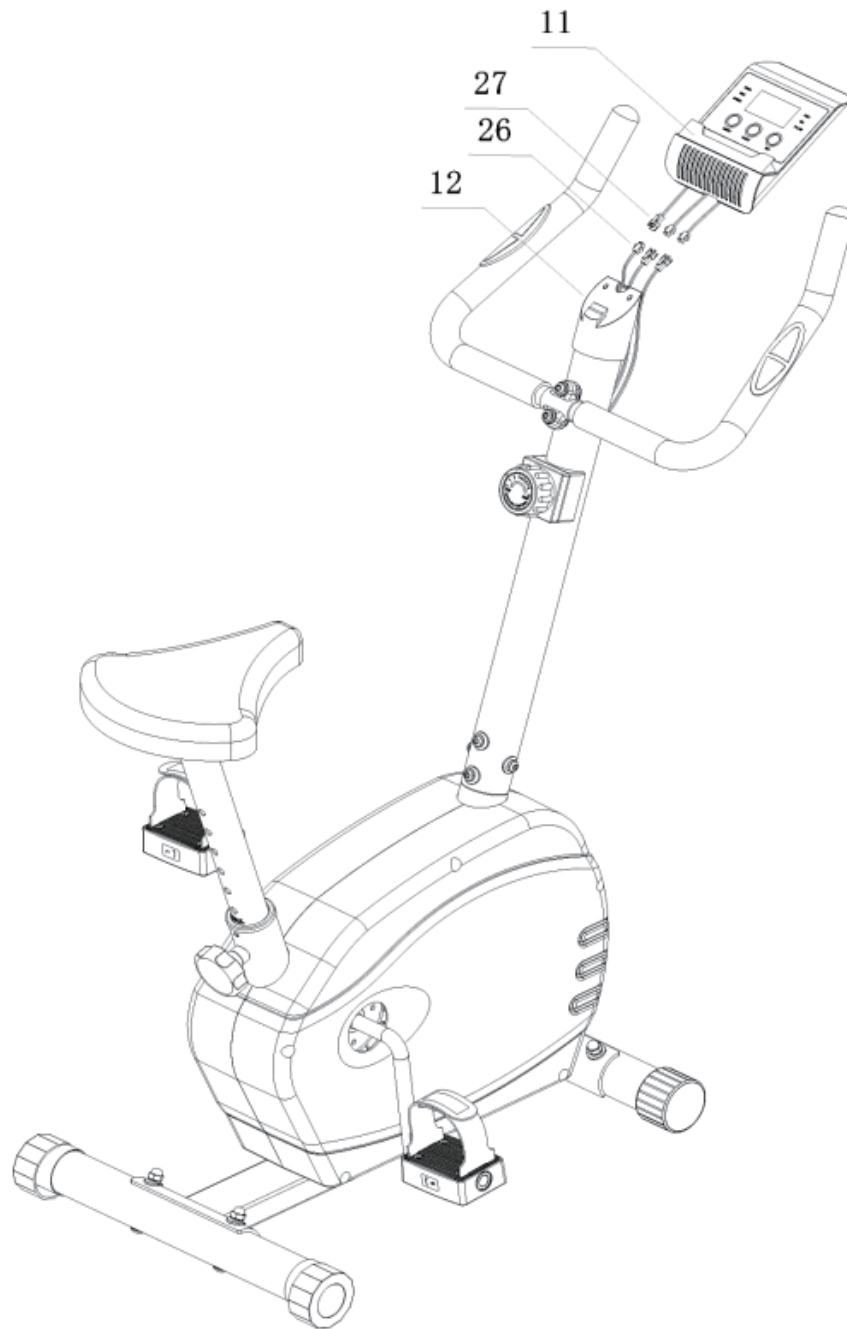

Step 5

Connecting the sensor lines and the electronic watch:

- Connect sensor line 01 (26) and sensor line 02 (27) to their respective interfaces, as shown in the figure.
- Insert the electronic watch (11) into the electronic watch installation plastic part.
- Double-check the installation before use.

Electronic watch function

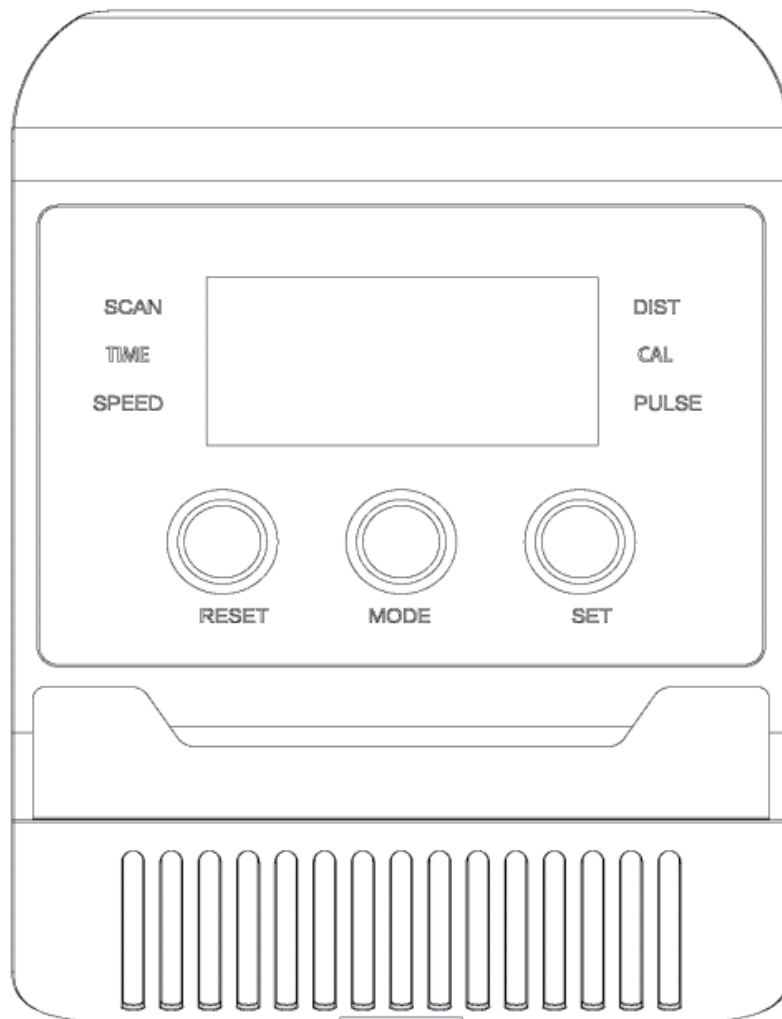

SCAN: Perform function switching.

TIME: Set the time range from 00:00-99:59 minutes.

SPEED: Adjust the range from 00-99km (mile) per hour.

DIST: Set the distance range from 0.00-99.99km (miles).

ODO: Measure the distance travelled from 0.0-999.9km (miles) (if configured).

PULSE: Measure the pulse rate from 40-240 bpm (if configured).

CAL: Calculate the calorie consumption from 0.0-999.9 Kcal.

Electronic watch operation instructions

Button functions

MODE: Used to select applicable functions.

RESET: Clears the function data when selected.

SET: Used to set the target number and turn on the countdown function.

Instructions

1. Switch on

When any key is pressed or you begin cycling, the monitor will start working. If inactive for four minutes, the monitor will automatically turn off.

2. Clear

In any state, hold the selection button for three seconds to clear all function data except the total distance.

3. Mode

When the function indication on the display screen flashes, the monitor enters automatic scan mode. Press the selection button again to enter lock mode and stay on a certain function.

4. Functions and settings

- **Time:** Press this button to display the current exercise time.
- **Speed:** Press this button to display the instant movement speed.
- **Distance:** Press this button to display the current movement distance.
- **Total distance (if configured):** Press 'ODO' to record the total distance of your exercise. The data will reset to zero after powering on again.
- **Heartbeat (if configured):** Press the 'PULSE' button. Hold the sensor with both hands when using it – the monitor will display your bpm after 30 seconds.
- **Calories burned:** Press the 'CALORIE' button to display the calories consumed.
- **Scan:** When the arrow on the display flashes, the monitor will automatically scan in the following order: speed, distance, time, total distance, calorie consumption, heartbeat and speed.

Electronic watch battery

This monitor uses two AAA batteries.

Daily maintenance and cleaning

- Use a soft cloth to wipe away any dust on the exercise bike. Avoid using abrasives or solvents on any plastic parts.
- After each use, wipe off any sweat from the bike.
- Keep this product away from direct sunlight, especially the electronic watch as it could be sensitive.
- Regularly check all screws for looseness. Tighten them if needed.
- Regularly apply lubricating oil to the exercise bike, ensuring a smooth operation.
- Store the exercise bike in a clean and dry environment, away from children.

Troubleshooting

- To stop the exercise bike from shaking, rotate the pipe plugs at both ends of the rear leg assembly, making them level with the front assembly.
- If the screen does not display anything, check the wiring connection between the armrest and the monitor, ensure the battery is correctly installed and replace the battery if necessary.
- If there is a squeaking sound during use, check for loose bolts and ensure they are tightened securely.

UK

If you have any questions, please contact our customer care center.

Our contact details are below:



0044-800-240-4004



enquiries@mhstar.co.uk

IMPORTER ADDRESS:

MH STAR UK LTD

Unit 27, Perivale Park,
Horsenden lane South

Perivale, UB6 7RH

MADE IN CHINA

ES

Si tiene alguna pregunta, comuníquese con nuestro Centro de Atención al Cliente. Nuestros datos de contacto son los siguientes:



0034-931294512



atencioncliente@aosom.es

IMPORTADOR:

SPANISH AOSOM, S.L.

C/ ROC GROS, N° 15. 08550, ELS HOSTALETS DE
BALENYÀ, SPAIN.

B66295775

WWW.AOSOM.ES

ATENCIONCLIENTE@AOSOM.ES

TEL: 931294512

HECHO EN CHINA

FR

Si vous avez la moindre question, veuillez contacter notre centre d'assistance à la clientèle.

Nos coordonnées sont les suivantes:



0033-1-84166106



aosom@mhfrance.fr

Importé par:

MH France

2, rue Maurice Hartmann

92130 Issy-les-Moulineaux

France

Fabriqué en Chine

PT

Se tiver alguma dúvida, por favor contacte o nosso Centro de Atendimento ao Cliente. Os nossos dados de contacto são os seguintes:



0034-931294512



info@aosom.pt.

IMPORTADOR:

SPANISH AOSOM, S.L

C.ROC GROS N.15, 08550. ELS HOSTALETS DE BALENYÀ

TEL: 931294512 (SEG-SEX DAS 7:30H ÀS 16:30H)

INFO@AOSOM.PT

WWW.AOSOM.PT

DE

Wenn Sie Fragen haben, wenden Sie sich bitte an unser Kundendienstzentrum.

Unsere Kontaktdaten stehen unten:



0049-(0)40-88307530



service@aosom.de

ADRESSE DES IMPORTEURE:

MH Handel GmbH

Wendenstraße 309

D-20537 Hamburg

Germany

IN CHINA HERGESTELLT

IT

In caso di dubbio, si prega di contattare il nostro centro assistenza clienti. I nostri dettagli di contatto sono di seguito:



0039-0249471447



clienti@aosom.it

IMPORTATO DA:

AOSOM Italy srl

Centro Direzionale Milanofiori

Strada 1 Palazzo F1

20057 Assago (MI)

P.I.: 08567220960

FATTO IN CINA

