

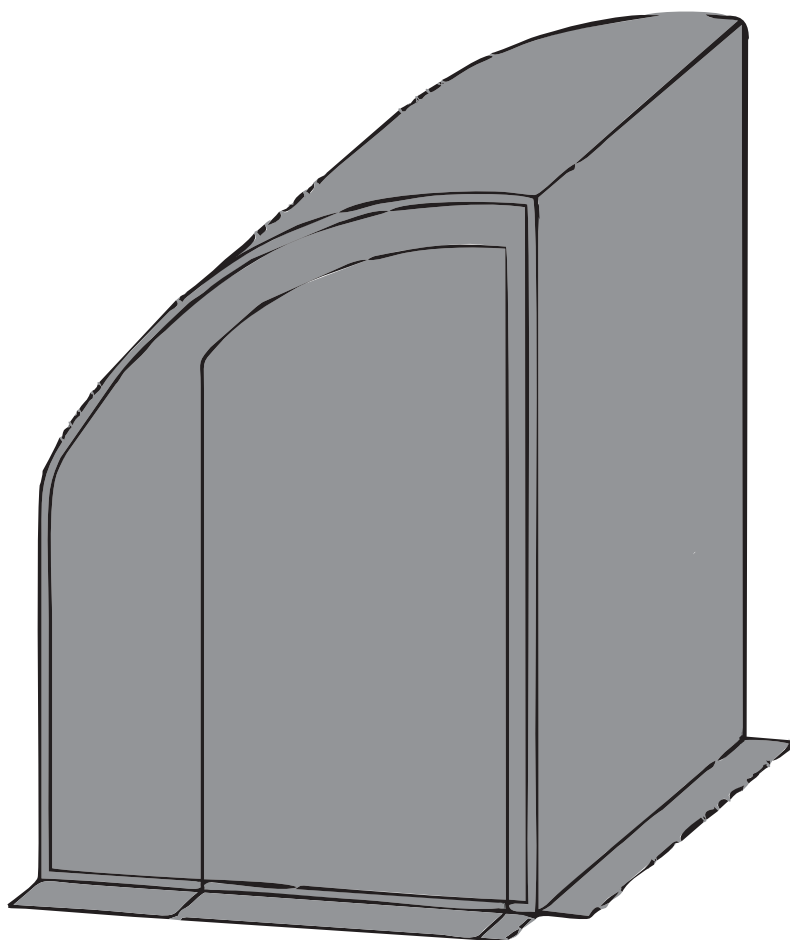

IN240300217V01_GL

845-592V02



EN_IMPORTANT, RETAIN FOR FUTURE REFERENCE: READ CAREFULLY.

**FR_IMPORTANT: A LIRE ATTENTIVEMENT ET À CONSERVER POUR CONSULTATION
ULTÉRIEURE.**

ES_IMPORTANTE, LEA Y GUARDE PARA FUTURAS REFERENCIAS.

PT_IMPORTANTE, RETER PARA REFERÊNCIA FUTURA: LEIA ATENTAMENTE.

DE_WICHTIG! SORFGFÄLTIG LESEN UND FÜR SPÄTERES NACHSCHLAGEN AUFBEWAHREN.

**IT_IMPORTANTE! CONSERVARE IL PRESENTE MANUALE PER FUTURO RIFERIMENTO E
LEggerlo ATTENTAMENTE.**

EN

1. At least 2 people are required to assemble the product;
2. It needs to be installed against the wall, fixed to the wall with wall nails J, and fixed to the ground with U-shaped nails
3. When installing the cover, first open the doors of both sides, then put the cover over the frame slowly to prevent be scratched.

FR

1. Au moins 2 personnes sont nécessaires pour assembler le produit ;
2. Il doit être installé contre le mur, fixé au mur avec des clous muraux J, et fixé au sol avec des clous en forme de U.
3. Lors de l'installation du couvercle, ouvrez d'abord les portes des deux côtés, puis placez lentement le couvercle sur le cadre afin d'éviter les rayures.

ES

1. Para montar el producto se necesitan al menos 2 personas;
2. Es necesario instalarlo contra la pared, fijarlo a la pared con clavos de pared J y fijarlo al suelo con clavos en forma de U
3. Cuando instale la cubierta, abra primero las puertas de ambos lados y, a continuación, coloque la cubierta sobre el marco lentamente para evitar que se raye.

PT









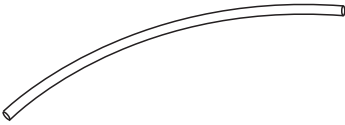

1. São necessárias pelo menos 2 pessoas para montar o produto;
2. Tem de ser instalado contra a parede, fixado à parede com pregos de parede J e fixado ao chão com pregos em forma de U
3. Ao instalar a cobertura, abrir primeiro as portas de ambos os lados e, em seguida, colocar a cobertura sobre o caixilho lentamente para evitar que seja riscada.

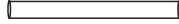
DE

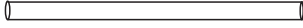

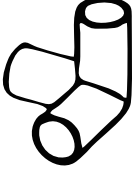
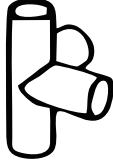
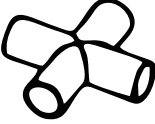

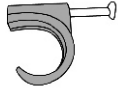

1. Für den Zusammenbau des Produkts sind mindestens 2 Personen erforderlich;
2. Es muss an der Wand installiert, mit Wandnägeln J an der Wand befestigt und mit U-förmigen Nägeln am Boden befestigt werden.
3. Wenn Sie die Abdeckung installieren, öffnen Sie zuerst die Türen auf beiden Seiten, dann legen Sie die Abdeckung langsam über den Rahmen, um Kratzer zu vermeiden.

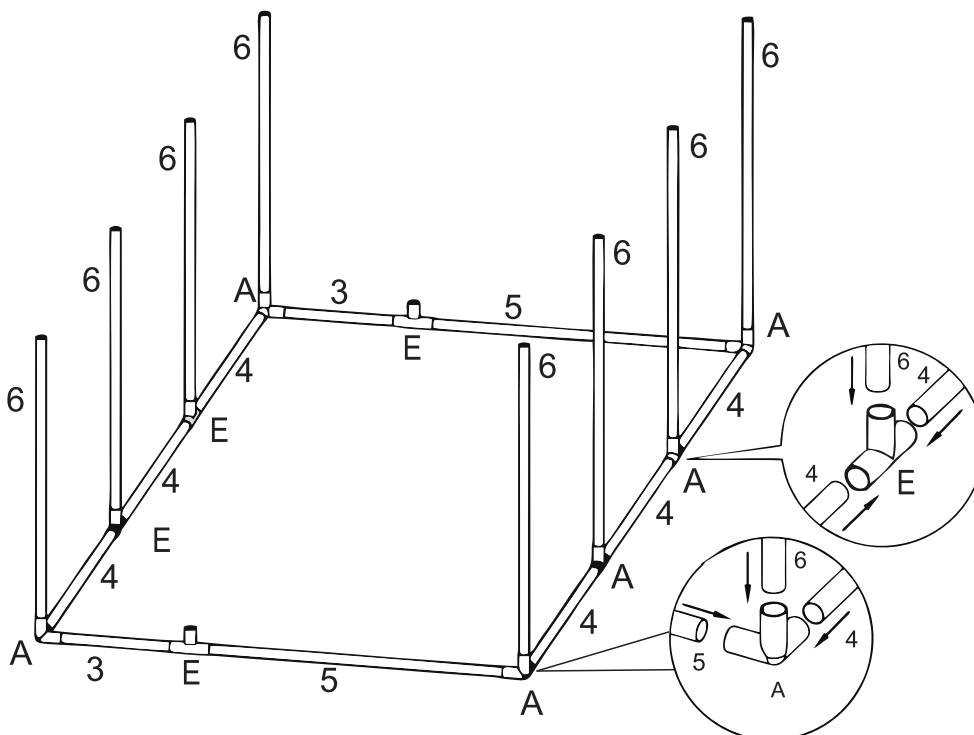
IT





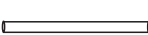

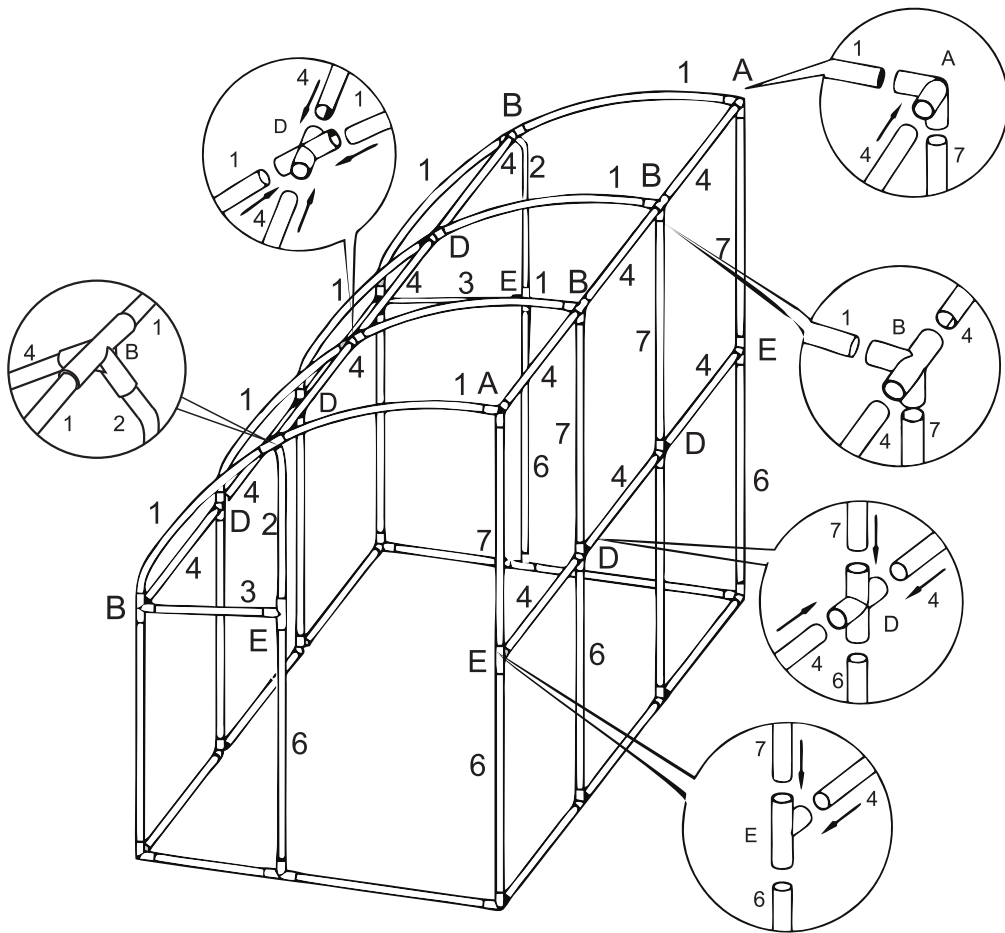

1. Per l'assemblaggio del prodotto sono necessarie almeno 2 persone;
2. Deve essere installato contro la parete, fissato alla parete con chiodi a muro J e fissato a terra con chiodi a U.
3. Quando si installa la copertura, aprire prima le porte di entrambi i lati, quindi mettere la copertura sul telaio lentamente per evitare che si graffi.

 1 x 8	 2 x 2	 3 x 4
 4 x 18	 5 x 2	 6 x 10
 7 x 4	 A x 6	 B x 6
 D x 6	 E x 10	 G x 1
	 I x 4	 J x 4



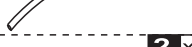

 A x 4
 E x 6
 3 x 2
 4 x 6
 5 x 2
 6 x 8

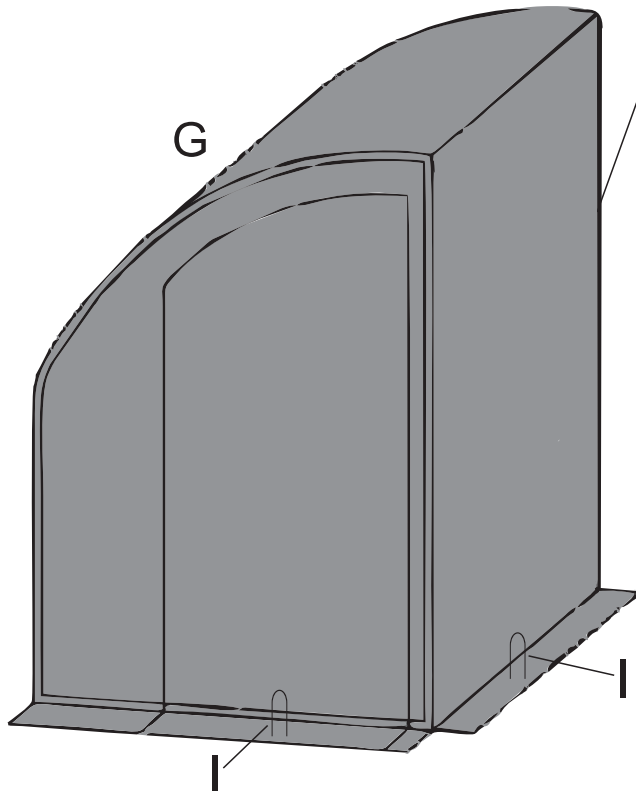

-  **A x 2**
-  **B x 6**
-  **D x 6**
-  **E x 4**
-  **1 x 8**
-  **2 x 2**
-  **3 x 2**
-  **4 x 12**
-  **6 x 2**
-  **7 x 4**

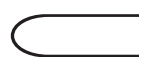

-  **G x 1**
-  **I x 4**
-  **J x 4**

If you have any questions, please contact our customer care center.

Our contact details are below:

 001-877-644-9366

 customerservice@aosom.com

Imported by Aosom LLC

27150 SW Kinsman Rd Wilsonville, OR 97070 USA

MADE IN CHINA

US

Si tiene alguna pregunta, comuníquese con nuestro Centro de Atención al Cliente.

Nuestros datos de contacto son los siguientes:

 0034-931294512

 atencioncliente@aosom.es

IMPORTADOR:

SPANISH AOSOM, S.L.

C/ ROC GROS, Nº 15. 08550, ELS HOSTALETES DE BALENYÀ, SPAIN.

B66295775

WWW.AOSOM.ES

HECHO EN CHINA

ES

If you have any questions, please contact our customer care center.

Our contact details are below:

 416-792-6088

 customerservice@aosom.ca

Imported by Aosom Canada Inc.

7270 Woodbine Avenue, Unit 307, Markham,

Ontario Canada L3R 4B9

MADE IN CHINA

CA

Se tiver alguma dúvida, por favor contacte o nosso Centro de Atendimento ao Cliente.

Os nossos dados de contacto são os seguintes:

 0034-931294512 (SEG-SEX DAS 7:30H ÀS 16:30H)

 info@aosom.pt.

IMPORTADOR:

SPANISH AOSOM, S.L

C.ROC GROS N.15, 08550. ELS HOSTALETES DE BALENYÀ

WWW.AOSOM.PT

PT

Si vous avez la moindre question, veuillez contacter notre centre d'assistance à la clientèle.

Nos coordonnées sont les suivantes:

 416-792-6088

 customerservice@aosom.ca

Importé par Aosom Canada Inc.

7270 Woodbine Avenue, unité 307,

Markham, Ontario Canada L3R 4B9

Fabriqué en Chine

DE

Wenn Sie Fragen haben, wenden Sie sich bitte an unser Kundendienstzentrum.

Unsere Kontaktdaten stehen unten:

 0049-0(40)-88307530  service@aosom.de

ADRESSE DES IMPORTEURS:

MH Handel GmbH

Wendenstraße 309

D-20537 Hamburg

Germany

IN CHINA HERGESTELLT

IT

In caso di dubbio, si prega di contattare il nostro centro assistenza clienti.

I nostri dettagli di contatto sono di seguito:

 0039-0249471447  clienti@aosom.it

IMPORTATO DA:

AOSOM Italy srl

Centro Direzionale Milanofiori

Strada 1 Palazzo F1

20057 Assago (MI)

P.I.: 08567220960

FATTO IN CINA

If you have any questions, please contact our customer care center.

Our contact details are below:

 0044-800-240-4004

 enquiries@mhstar.co.uk

IMPORTER ADDRESS:

MH STAR UK LTD

Unit 27, Perivale Park,

Horsenden lane South

Perivale, UB6 7RH

MADE IN CHINA

UK

Si vous avez la moindre question, veuillez contacter notre centre d'assistance à la clientèle.

Nos coordonnées sont les suivantes:  0033-1-84166106  aosom@mhfrance.fr

Importé par: MH France 2, rue Maurice Hartmann 92130 Issy-les-Moulineaux

Fabriqué en Chine

France

FR



FR

**DONNEZ
OU
RECYCLEZ**



OU



OU



ASSOCIATION LIVRAISON DÉCHÈTERIE

Adresses sur quefairedemesdechets.fr