

SPORTNOW

IN240400019V01_UK

A90-364V00

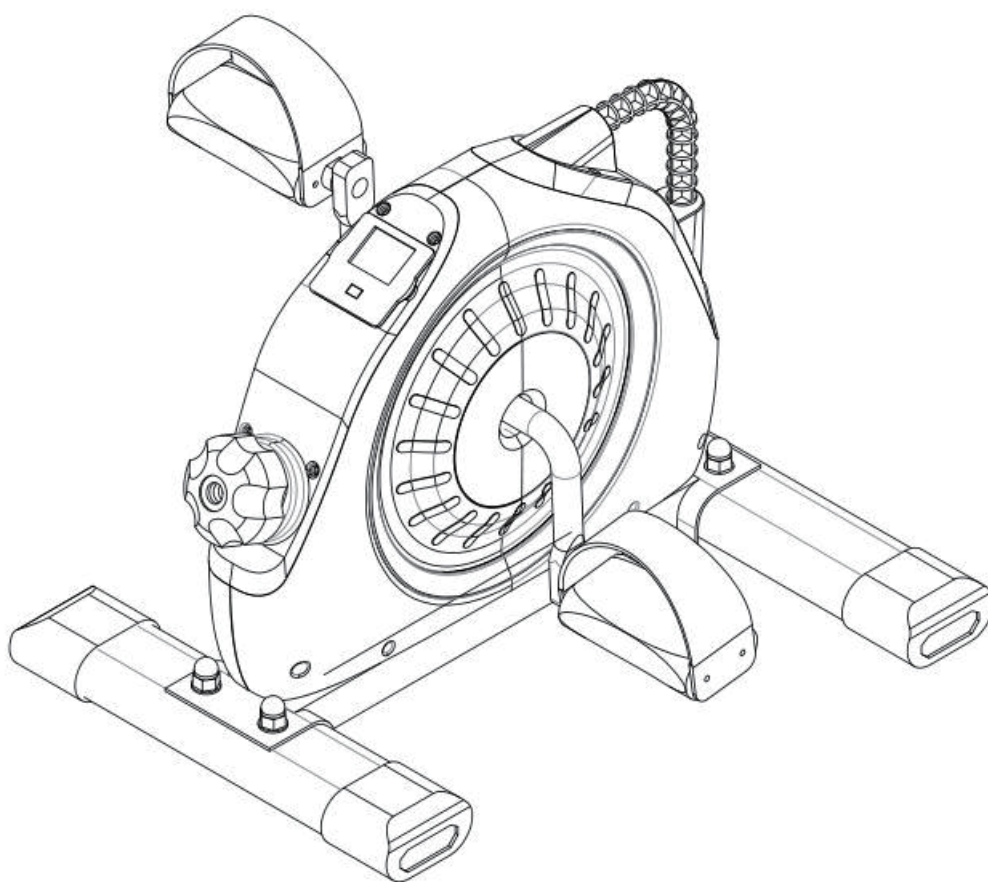

IMPORTANT, RETAIN FOR FUTURE REFERENCE: READ CAREFULLY

ASSEMBLY INSTRUCTIONS

Important safety warnings

IMPORTANT NOTICE! MUST READ!

Workouts provided in this manual are for reference purposes only. Before attempting any exercises or training programmes, it is essential to seek proper professional guidance.

It is strongly recommended to consult a qualified fitness instructor, trainer or healthcare professional. They can assess your capabilities and provide personalized instructions tailored to your needs.

The manufacturer is not liable for any injuries resulting from the use of this information. Your safety and well-being are paramount, so always prioritise your health and consult a professional for accurate guidance.

- Before using this product, consult your doctor to ensure you are in good health.
- Before installation and usage, read all instructions and warnings carefully.
- Keep this product on a flat and hard surface.
- Very important: Sports shoes must be worn while exercising. If you feel any pain or dizziness, stop training immediately and consult your doctor.
- Never use this product while standing.

Parts list

- ① Screw bag
- ② Pedal
- ③ Front foot tube
- ④ Back foot tube
- ⑤ Main part



Assembly steps

Install the short front tube ③. Then, remove the screw and wrench from the screw package ①. Note: Refer to Figure 1 for the pin position of the mounting body ⑤ - it should face towards you when you face the screen. Once the short front tube ③ is installed, proceed to install the back tube ④ according to Figure 2, then secure the screws in the given order.

The right pedal ② is marked with 'R' at the end of the pedal shaft. Connect it to the right crank arm and tighten it clockwise.



Figure 1



Figure 2

The left pedal ② is marked with 'L' at the end of the pedal shaft. Connect it to the left crank arm and tighten it anticlockwise.



Before using this product, ensure all bolts and nuts are securely tightened. Refer to the manual for further instructions.



Display shows TIME

Symbol	Meaning	Description
T	Time	The amount of time that has passed since the start of training.
D	Distance	Covers the distance in kilometers.
C	Count	Accumulate the moves Sain does during the workout
T-C	Gross count	The accumulated cycling movements or counts cannot be reset unless the battery is replaced.
CA	Calories	Estimates heat generated from movement. Used to quantify energy expenditure during physical activities. Regular exercise burns

Press the red button to select your desired function.

Battery installation/replacement

- 1.Remove the counter from the top of the main body.
- 2.Insert or replace a 1.5V AAA battery into the counter at the top of the body, ensuring it matches the indicated polarity symbol.
- 3.Press the computer back onto the top of the main body.

Note: When removing the counter from the top of the body, the wire that connects the counter to the sensor bar may become loose. Before pressing the counter back in place, ensure the wire is securely connected to both the counter and sensor bar.

For cleaning and maintenance, follow these guidelines:

- Avoid contact with water.
- Clean with a slightly damp sponge and dry with a clean, dry cloth.
- Keep the product out of direct sunlight.

Using the product:

Legs: Place the device on a flat, sturdy surface with enough space to safely enter and move around. Place a chair in front of the machine. Refer to the image below for proper positioning. Slide your feet into the foot pedals.

Arms: Place the product on a table in front of you. Hold onto the foot pedal with your hands.

Press the red button to activate the LCD control panel. You can select different features by pressing the red button.



UK

If you have any questions, please contact our customer care center.

Our contact details are below:



0044-800-240-4004



enquiries@mhstar.co.uk

IMPORTER ADDRESS:

MH STAR UK LTD

Unit 27, Perivale Park,
Horsenden lane South

Perivale, UB6 7RH

MADE IN CHINA

ES

Si tiene alguna pregunta, comuníquese con nuestro Centro de Atención al Cliente. Nuestros datos de contacto son los siguientes:



0034-931294512



atencioncliente@aosom.es

IMPORTADOR:

SPANISH AOSOM, S.L.

C/ ROC GROS, N° 15. 08550, ELS HOSTALETS DE
BALENYÀ, SPAIN.

B66295775

WWW.AOSOM.ES

ATENCIONCLIENTE@AOSOM.ES

TEL: 931294512

HECHO EN CHINA

FR

Si vous avez la moindre question, veuillez contacter notre centre d'assistance à la clientèle.

Nos coordonnées sont les suivantes:



0033-1-84166106



aosom@mhfrance.fr

Importé par:

MH France

2, rue Maurice Hartmann

92130 Issy-les-Moulineaux

France

Fabriqué en Chine

PT

Se tiver alguma dúvida, por favor contacte o nosso Centro de Atendimento ao Cliente. Os nossos dados de contacto são os seguintes:



0034-931294512



info@aosom.pt.

IMPORTADOR:

SPANISH AOSOM, S.L

C.ROC GROS N.15, 08550. ELS HOSTALETS DE BALENYÀ

TEL: 931294512 (SEG-SEX DAS 7:30H ÀS 16:30H)

INFO@AOSOM.PT

WWW.AOSOM.PT

DE

Wenn Sie Fragen haben, wenden Sie sich bitte an unser Kundendienstzentrum.

Unsere Kontaktdaten stehen unten:



0049-(0)40-88307530



service@aosom.de

ADRESSE DES IMPORTEURE:

MH Handel GmbH

Wendenstraße 309

D-20537 Hamburg

Germany

IN CHINA HERGESTELLT

IT

In caso di dubbio, si prega di contattare il nostro centro assistenza clienti. I nostri dettagli di contatto sono di seguito:



0039-0249471447



clienti@aosom.it

IMPORTATO DA:

AOSOM Italy srl

Centro Direzionale Milanofiori

Strada 1 Palazzo F1

20057 Assago (MI)

P.I.: 08567220960

FATTO IN CINA

